

**MERCUISER**  
**VOLVO**  
**OMC**  
**YANMAR**

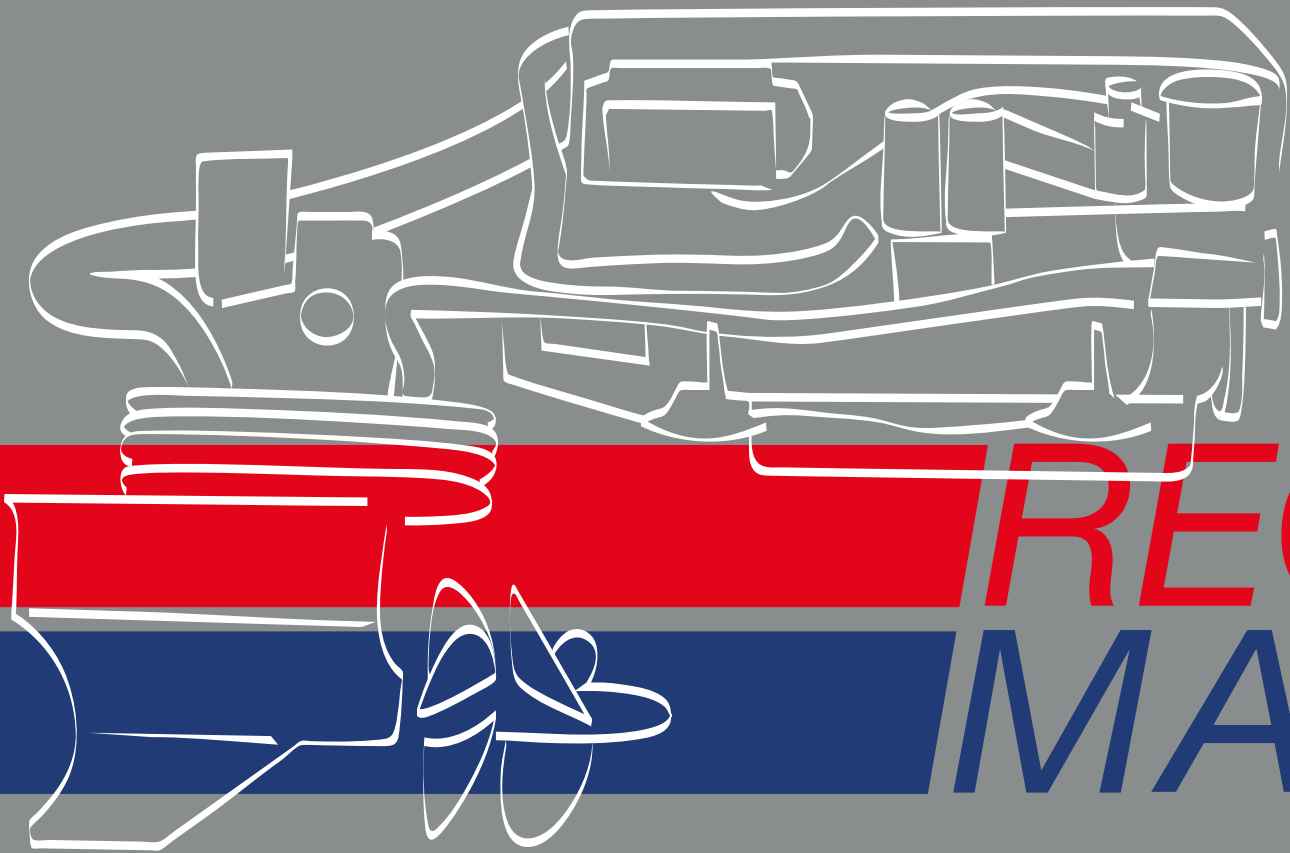

**RECA**  
**MARI**

**2019-2020**

**MOTOR**  
**REPUESTOS**  
**HERRAMIENTAS**  
**LUBRICANTES**

**ENGINE**  
**SPARE PARTS**  
**TOOLS**  
**LUBRICANTS**

**MOTORE**  
**RICAMBI**  
**ATTREZI**  
**LUBRIFICANTI**

**DENTRO-FUERABORDA**  
**OUT-INBOARD**  
**ENTRO-FUORIBORDO**

# 2019-2020

## DENTRO-FUERABORDA OUT-INBOARD ENTRO-FUORIBORDO

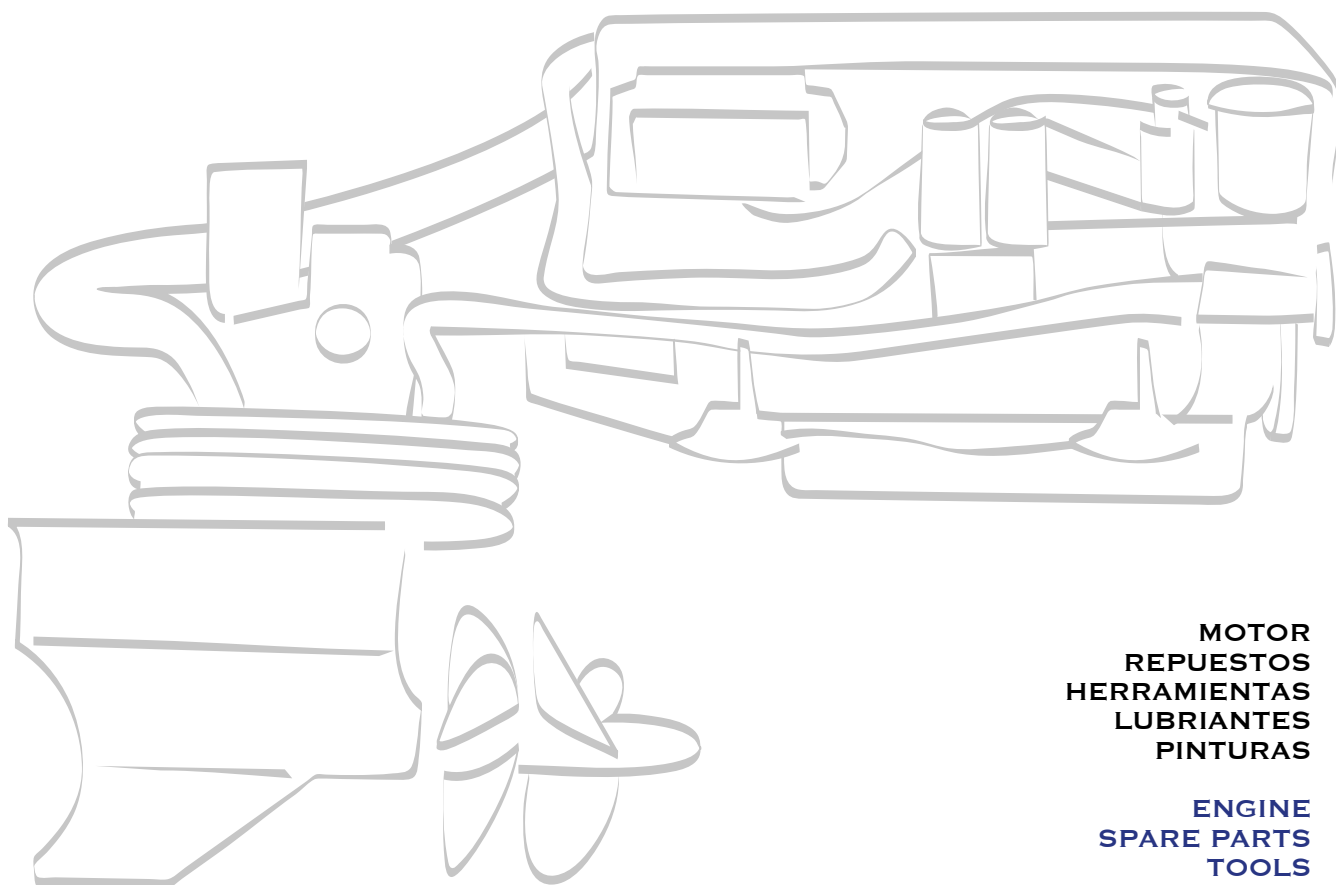

**MOTOR  
REPUESTOS  
HERRAMIENTAS  
LUBRIANTES  
PINTURAS**

**ENGINE  
SPARE PARTS  
TOOLS  
LUBRICANTS  
PAINTS**

**MOTORE  
RICAMBI  
ATTREZI  
LUBRIFICANTI  
VERNICI**



ALBANIA  
ALEMANIA GERMANY  
ALGERIA ALGERIE  
ANDORRA  
AUSTRALIA  
BÉLGICA BELGIUM  
BULGARIA  
CROATIA CROATIA  
DINAMARCA DENMARK  
ESPAÑA SPAIN  
ESTONIA  
FINLANDIA FINLAND  
FRANCIA FRANCE  
GRECIA GREECE  
INDIA  
IRLANDA IRELAND  
ITALIA ITALY  
LETONIA LATVIA  
LITUANIA LITHUANIA

MALTA  
MARRUECOS MOROCCO  
MONTENEGRO  
HOLANDA NETHERLANDS  
NORUEGA NORWAY  
PORTUGAL  
ROMANIA  
RUSIA  
SERBIA  
ESLOVAQUIA SLOVAKIA  
TURQUÍA TURKEY  
UCRANIA UKRAINE  
REINO UNIDO UNITED KINGDOM



• **MERCUISER** 70  
REF --> R.O. / OEM 254

• **VOLVO** 271  
REF --> R.O. / OEM 482

• **OMC** 503  
REF --> R.O. / OEM 575

• **YANMAR** 583  
REF --> R.O. / OEM 622

BORG-WAGNER	628	PERKINS	672
CATERPILLAR	629	PLEASURECRAFT	675
CHRIS-CRAFT	633	RENAULT-COUACH	685
CRUSADER	639	SOLE DIESEL	687
CUMMINS	654	VETUS	688
DETROIT DIESEL	658	WESTERBEKE	690
HURT	660		
INDMAR	661	SHERWOOD	692
KOHLER	664	JABSCO	702
MAN	666	FILTROS / FILTERS / FILTRI	703
NANNI DIESEL	667		
ONAN	668	REF --> R.O. / OEM	709

ÍNDICE ACCESORIOS	ACCESSORIES TABLE OF CONTENTS	INDICE ACCESSORI	
TX MARINE	TX MARINE	TX MARINE	4
PINTURA PARA MOTORES	ENGINE SPARY PAINTS	VERNICI PER MOTORI	8
MANTENIMIENTO DE MOTORES	ENGINE MAINTENANCE	MANUTENZIONE MOTORI	9
LUBRICANTES	LUBRICANTS	LUBRIFICANTI	11
HERRAMIENTAS	TOOLS	ATTREZZI	17
RÁCORES Y TORNILLERÍA	RACCORS & FITTINGS	RACCORDI E VITERIA	28
MANGUERAS ESCAPE	EXHAUST HOSES	TUBI DI SCARICO	29
LLAVES DE ARRANQUE	IGNITION STARTER SWITCHES	CHIAVE DI AVVIAMETO	30
IDENTIFICACIÓN DE MOTORES	ENGINE'S IDENTIFICATION	IDENTIFICAZIONE MOTORE	31
EQUIPAMIENTO STANDARD BASE MOTORES GM NUEVOS	GM STANDARD EQUIPMENT BASE NEW ENGINE	VERSIONE STANDARD BASE MOTORE GM NUOVO	33
BLOQUES Y CULATAS REMANUFACTURADOS GM Y FORD	GM & FORD REBUILT LONG BLOCKS & CYLINDER HEADS	BLOCCHI E TESTATE RIGENERATI GM E FORD	36
DESPIECE BLOQUE MOTOR GM	GM ENGINE BLOCK PARTS	ESPLOSI BLOCCO MOTORE GM	40
DESPIECE BLOQUE MOTOR FORD	FORD ENGINE PARTS	ESPLOSI BLOCCO MOTORE FORD	68

## IMPORTANTE

LOS PRODUCTOS QUE APARECEN EN NUESTROS CATALOGOS SON VÁLIDOS Y COMPATIBLES CON LOS MOTORES Y TRANSMISIONES DE LAS MARCAS ORIGINALES QUE APARECEN EN CADA SECCIÓN. EN ALGUNOS CASOS TAMBIÉN SUMINISTRAMOS RECAMBIO ORIGINALES. ESTA INFORMACIÓN APARECE CON LA REFERENCIA EN EL MOMENTO DE CONFIRMAR EL PEDIDO POR NUESTRA WEB.

LA IMÁGENES AQUÍ CONTENIDAS PUEDEN NO CORRESPONDER CON TOTAL PRECISIÓN AL PRODUCTO SUMINISTRADO. RECAMBIO MARINOS, S.L. SE RESERVA EL DERECHO DE ANULAR O CAMBIAR PRODUCTOS SIN PREVIO AVISO.

## IMPORTANT

THE PRODUCTS THAT APPEAR IN OUR CATALOGS ARE VALID AND COMPATIBLE WITH THE MOTORS AND TRANSMISSIONS OF THE ORIGINAL BRANDS THAT APPEAR IN EACH SECTION. IN SOME CASES WE ALSO SUPPLIED ORIGINAL SPARE PARTS. THIS INFORMATION APPEARS WITH THE REFERENCE AT THE TIME OF CONFIRMING THE ORDER BY OUR WEB.

IMAGES CONTAINED HERE MAY NOT CORRESPOND WITH TOTAL ACCURACY TO THE PRODUCT SUPPLIED. RECAMBIO MARINOS, S.L. RESERVES THE RIGHT TO CANCEL OR CHANGE PRODUCTS WITHOUT PRIOR NOTICE.

## IMPORTANTE

I PRODOTTI CHE COMPAGNONO NEI NOSTRI CATALOGHI SONO VALIDI E COMPATIBILI CON I MOTORI E LE TRASMISSIONI DEI MARCHI ORIGINALI CHE APPAIONO IN OGNI SEZIONE. IN ALCUNI CASI ABBIAMO FORNITO ANCHE RICAMBI ORIGINALI. QUESTA INFORMAZIONE RISULTA CON IL RIFERIMENTO AL MOMENTO DELLA CONFERMA DELL'ORDINE DA PARTE DEL NOSTRO WEB.

LE IMMAGINI QUI CONTENUTE POTREBBERO NON CORRISPONDERE ESATTAMENTE AL PRODOTTO FORNITO. RECAMBIO MARINOS, S.L., SI RISERVA IL DIRITTO DI CANCELLARE O MODIFICARE I PRODOTTI SENZA PREAVVISO.



## AXONE NEMO

### La primera diagnosis Smart en el mundo

Axone Nemo es un potente tablet diseñado para asegurar al mecánico un óptimo uso, tanto en el entorno de taller, como en las intervenciones en el exterior.

Permite efectuar operaciones de diagnosis a gran velocidad. El chasis de magnesio le proporciona una mayor robustez y rigidez ante los golpes, muy ligero con gran capacidad de disipación de la temperatura interna. El software operativo IDC5 destaca todas sus características, además del "touch gesture" para alcanzar en poco tiempo las funciones deseadas.

## AXONE NEMO

### The first Smart diagnosis in the world

Axone Nemo is a powerful tablet designed to ensure the mechanic optimal use, both in the workshop environment, as interventions abroad.

It allows to carry out diagnosis operations at high speed. The magnesium chassis provides greater robustness and rigidity against shock, very light with great capacity to dissipate the internal temperature.

The IDC5 operating software highlights all its features, in addition to the "touch gesture" to reach the desired functions in a short time.

## AXONE NEMO

### La prima diagnosi Smart nel mondo

Axone Nemo è un potente tablet creato per assicurare al meccanico un ottimo uso, sia nelle officine sia negli interventi all'esterno.

Permette di effettuare operazioni di diagnosi a gran velocità. La scocca in magnesio gli dona una maggior robustezza contro i colpi, molto leggero.. Il software operativo IDC5 evidenzia tutte le sue caratteristiche, come il "touch gesture" per eseguire in poco tempo le funzioni desiderate..

PANTALLA	SCREEN	SCREEN	12" (2160 x 1440)
PROCESADOR	PROCESSOR	PROCESSORE	Intel Quad Core N3160
RAM	RAM	RAM	8 GB
MEMORIA	MEMORY	MEMORIA	250 GB
WIFI Doble canal	WIFI Double channel	WIFI doppio canale	Doble canal
BLUETOOTH			4.0 Low Energy
2 CÁMARAS	2 CAMERA	2 FOTOCAMERE	5 Megapixels

## SOFTWARE IDC5

IDC5 es la última evolución de TEZA, gracias a la reescritura del código se incrementa la velocidad de trabajo, lo que garantiza una entrada de comunicación con la centralita casi inmediata. La nueva función "Esquemas eléctricos interactivos" permite consultar los esquemas eléctricos aprovechando las animaciones de los dispositivos implicados y generando un mapa interactivo con flujos de señales entrada o salida de centralitas.

## SOFTWARE IDC5

IDC5 is the latest evolution of TEZA, thanks to the rewriting of the code the working speed is increased, which guarantees a communication input with the control unit almost immediately. The new function "Interactive electrical diagrams" allows consulting the electrical diagrams taking advantage of the animations of the devices involved and generating an interactive map with flows of signals input or output of control units.

## SOFTWARE IDC5

IDC5 è l'ultima evoluzione di TEZA, grazie ai nuovi aggiornamenti, si incrementa la velocità di lavoro, che garantisce la comunicazione quasi immediata con l'unità di controllo. La nuova funzione "Diagrammi interattivi elettronici" permettono di consultare i diagrammi elettronici con l'animazione dei led generando una mappa interattiva con un flusso di segnali in entrata e in uscita della centralina.



Ref.

RECAXONEMO	Axone Nemo		
RECD06591	Navigator TXB Evolution		
RECD127X0	Axone Nemo + Navigator TXB Marine		
RECZ06590PC	Navigator TXB + PC	Navigator TXB + Labtop	
REC3901775	Kit maleta para guardar cables de interface	Hand case for harnesses	Kit per cavi intergaccia
RECAGA00M1	Contrato de actualización software (y renovación anual).	Software contract and annual renovation	Contratto software (e rinnovo annuale).

**TEXA**

# NAVIGATOR TXB EVOLUTION & AXONE NEMO / PC



SRAM	SRAM	SRAM	16Mb
MEMORIA	MEMORY	MEMORIA	NAND Flash 8 GB
BLUETOOTH			

## NAVIGATOR TXB EVOLUTION

The evolution of the diagnosis, designed and developed specifically for the marine environment.

The characteristics of the hardware make it compatible with all currently existing protocols, its integrated 16-pole CPC connector, allows the use of all diagnostic cables. It is compatible with AXONE NEMO and PC. Thanks to Bluetooth technology, the technician can make a comfortable diagnosis without wires, even from the jetty.

Extremely powerful, they allow the mechanic to easily manage the map files. The CAN standards supported include the possibility of CAN single wire management and a further CAN controller for the diagnosis of more networks.

It allows the recording of the diagnosis session in "dynamic tests" mode, that is to say with the boat in motion, to locate specific faults that could not be verified in the mooring. The interface reconstructs a complete panorama of the situation in which the anomaly has been verified, providing important elements of analysis to identify the causes of the failure.

**NEW**

## NAVIGATOR TXB EVOLUTION

La evolución de la diagnosis, diseñado y desarrollado específicamente para el ambiente Marino.

Las características del hardware lo compatibilizan con todos los protocolos actualmente existentes, su conector CPC de 16 polos integrados, permite el uso de todos los cables de diagnosis. Es compatible con AXONE NEMO y PC. Gracias a la tecnología Bluetooth el técnico podrá realizar una cómoda diagnosis sin cables de por medio, incluso desde el pantalán.

Extremadamente potente, permite al mecánico una gestión fácil de los archivos de mapa. Los estándares CAN soportados incluyen la posibilidad de gestión CAN single wire y un CAN controller más para la diagnosis sobre más redes.

Permite la grabación de la sesión de diagnosis en modalidad "pruebas dinámicas", es decir con la embarcación en movimiento, para localizar averías específicas que no se podrían verificar en el amarre. La interfaz reconstruye una panorámica completa de la situación en la que la anomalía se ha verificado, proporcionando importantes elementos de análisis para identificar las causas de la avería.

## NAVIGATOR TXB EVOLUTION

L'evoluzione della diagnosi, disegnato e sviluppato specificamente per l'ambiente Marino.

Le caratteristiche hardware lo rendono compatibile con tutti i protocolli attualmente esistenti, il suo connettore CPC 16 poli integrato consente l'utilizzo di tutti i cavi diagnostici. E' compatibile con AXONE NEMO e PC. Grazie alla tecnologia Bluetooth il tecnico potrà realizzare una diagnosi senza cavi in mezzo, anche dal molo.

Estremamente potente, permette al meccanico una gestione facile degli archivi della mappa. Gli standard CAN supportati offrono la possibilità di gestire: CAN single wire e un altro CAN controller per eseguire le diagnosi su più reti.

Permette la registrazione di una sessione di diagnosi in modalità "prova dinamica", ovvero con l'imbarcazione in movimento, per constatare avarie specifiche che non si possono verificare in officina. La sua interfaccia permette di ricostruire una panorámica completa della situazione in cui l'anomalia si è verificata, fornendo gli elementi per identificare le eventuali avarie.

## APLICACIONES APPLICATIONS APPLICAZIONI

Consulte la lista actualizada de aplicaciones en:

See the updated list of applications in:

Vedi l'elenco aggiornato delle applicazioni in:

[www.texaiberica.com/cobertura-diagnosis](http://www.texaiberica.com/cobertura-diagnosis)

### MOTORES FUERABORDA OUTBOARD ENGINES MOTORI FUORIBORDO

	MODELOS MODELS MODELLI
EVINRUDE	(90 - 250 Ficht Ram) E-Tec 25 - 300 HP, DFi
HONDA Marine	BF 40-250 HP
JOHNSON	4 Stroke
MARINER	4 Stroke, OptiMax, Verado, DFI, EFI
MERCURY	4 Stroke, OptiMax, Verado, DFI, EFI
MERCURY Racing	OPTIMAX, DSi, VERADO 400R
PARSUN	40 EFI
SELVA Marine	4 S troke EFI
SUZUKI Marine	DF 40 -300 HP
TOHATSU	MFS, BFV, BFT
YAMAHA Marine	F, T, Z 30 - 350 HP

### MOTORES INTRABORDA INBOARD ENGINES MOTORI ENTROBORDO

	MODELOS MODELS MODELLI
CATERPILLAR	3196, 3176, 3126B, 3508B, 3508C, C12, C12 Acert, C18 Acert Tier 2, C32 Acert IMO II, C32 Acert Tier 2, C32 Acert Tier 2 HP, 3512 B HD, C3512B, 3512C HD, 3512C, 3516B HD, 32 Acert Tier 2 H.P. Recreational, C32 Acert Tier 3, C7, C7 Acert, C9 Acert., 3516B, 3516C HD, 3516C, C15 Acert, C6.6 Acert
CF MOTO	CF3100C/P
CRUSADER	5.0, 5.7, 6.0, 8.1 MPI & HO MPI
CUMMINS / MW	QSD2.0-115 / 130 / 150 / 170, QSD2.8-220, QSD4.2-270 / 320 / 350, QSB5.9 / 6.7, QSC8.3, QSK19, QSL9, QSM11 (Sistema Inyección Bosch / System injection Bosch / Sistema Iniezione Bosch) Comon Rail
DAEDONG	D4DD
DAF MARINE	UPEC
FIAT	C13, C78, C87, GE CURSOR 250E, 350E, 400E, N40, N60, N67, S30
FNM	HPEP, HPE 80-300 HP
FORD MARINE	3.2
HYUNDAI SEASALL	D150P/S, D170J/P/S, S220P/S, S250J/P/S, U125J/P/S
ILMOR	5.7L, 6.0L, 6.2L, MV-8
INDMAR	5.7, 6.0, 8.1, Steyr 256 Diesel
KODIAK MARINE	2.4, 4.3, 5.3, 5.7, 6.0, 6.2L
KOHLER	
LOMBARDINI Marine	LDW 194 JMT, LDW 240 JMT
MAN	D2868, V8-1000, V8-1200
MARINE POWER	3.0, 4.3, 5.0, 5.7, 6.0, 6.2, 8.1L 350, 377, 454, 496, 496MAG, 3.0L, 4.3L, 5.0L, 5.7L, 6.2L, 7.4L, 8.1L, 8.2L, TBI, MPI, Black Scorpion, Vazer, Mandos SmartCraft, D2.8D-Tronic
MERCURUISER	
MERCURUISER Diesel	VM D-Tronic, VM (no D-Tronic), MD2.0-115/130/150/170, MD2.8-270/320/350, TDI3.0-230/260, TDI4.2
MERCURY Racing Inbord	SCI, EFI, QC4V, 500EFI, 520, 525EFI, 540, 565, 575, 600, 850, Scorpion 377
MTU	MDEC C2
PCM MARINE Engines	5.0L, 5.7L, 6.0L, 8.1L
PERKINS	1106C-E6OTA 6.0L
SEA-DOO	Speedster, Challenger, Utopia, Islandia, Wake, Wake Speedster, Sportster
SISU AGCO	44 CTIM-2V, 49/66/74/84 CTIM-4V MO306H43WJ, MO54NA33, MO84K32, MO94K33, MO114K33, MO126M28, MO144M38, MO156K25, MO164M40, MO166M28, MO174V40, MO196K35, MO236K42, MO256H45, MO256H43, MO286H43 SE126E25, SE156E26, SE196E35, SE236E40, SE236S36 SE266, SE286, SE306J38
STEYR MOTORS	
VM MOTORI	2.8L, 4.2L D-Tronic, MD704, MD706, MR504LB
VOLKSWAGEN Marine	SDI, TDI
VOLVO PENTA	KAD, EDC, EGC, EVC, GXI, OSI, GI, GSI, OSXI, IPS, TAMD 4BY2-150 / 180, 6BY2-220 / 260 (Sistema Inyección Bosch / System injection Bosch / Sistema Iniezione Bosch)
YANMAR	4BY3-150/180, 4JH, 6BY3-220/260, 6LY3, 8LV-320/350/370

### MOTOS DE AGUA PWC MOTO D'ACQUA

	MODELOS MODELS MODELLI
HONDA Marine	Aquatrax
KAWASAKI Marine	STX, Ultra.
SEA-DOO	GTI, GTX, RXP, RXT, GTR, GTS, GTX-S, Spark, Wake Pro, Wake
YAMAHA Marine	Waverunner FX, FZR, FZS, GP, VX

## SIN CABLES DE INTERFACE WITHOUT INTERFACE CABLE SENZA CAVI INTERFACE

Ref.		CABLE WIRE CAVI
REC3902417	OBD, FNM Marine, VOLKSWAGEN, HYUNDAI	AM08
REC3902659	Marine FPT	AM11
REC3904277	Marine CUMMINS, MERCURISER Diesel, VM (not D-Tronic), KOHLER	AM24A
REC3905159	Marine VOLVO EGC 05/05>05/07	AM26
REC3905286	Marine MTU-MDEC	AM28
REC3905397	Marine CATERPILLAR, PERKINS	AM29
REC3906219	Marine TOHATSU	AM30
REC3906891	Marine MAN	AM31
REC3905015	Personal Water Craft KAWASAKI cable kit	



REC3902659

REC3902417



REC3904277



Conector redondo  
Round connector  
Connettore rotondo  
REC3905159



REC3905397



REC3905286



REC3906219



REC3906891



REC3905015

## INTERFACE AMO1

Ref. AM01

REC3902358



Ref.

CABLE  
WIRE  
CAVI

Ref.		CABLE WIRE CAVI
REC3902407	Marine HONDA / TOHATSU, PGM (FI)	AM02
REC3902247	Marine 2 pin MERCURY, MERCUISER	AM04
REC3902250	Marine 4 vie MERCURY, MERCUISER	AM05
REC3902413	Marine YAMAHA / SELVA	AM06
REC3902414	Marine 6 pin VOLVO PENTA	AM07
REC3902467	Marine VOLVO KAD - TAMD	AM09
REC3902864	Marine STEYR	AM12
REC3902865	Marine EVINRUDE	AM13
REC3902907	Marine VOLVO, MERCUISER (gasolina / fuel / benzina), MEFI-4, 4B,3,2,1, CRUSADER	AM14
REC3902931	Marine YANMAR	AM15
REC3903560	Marine SUZUKI	AM22
REC3905265	Marine MERCUISER / VM D-Tronic	AM27
REC3908405	PARSUNS	3151/AP54



REC3902247



REC3902407



REC3902413



REC3902250



REC3902414



REC3902467



REC3902864



REC3902865



REC3902907



REC3903560



REC3902931



REC3905265



REC3908405

## INTERFACE AMO1CAN

Ref. AM01CAN

REC3903008



Ref.

CABLE  
WIRE  
CAVI

Ref.		CABLE WIRE CAVI
REC3902960	Marine VOLVO, MERCUISER (gasolina / fuel / benzina), MEFI-5 / EGC, ILMOR, CRUSADER, ILMOR, INDMAR, PCM (MEFI-5/EGC UBD-Msocket)	AM16
REC3903502	Marine VOLVO, EGC-EV	AM18
REC3904778	Marine MERCURY, MARINER, CUMMINS 2010+, MANDOS MCM, SMARTCRAFT	AM25
REC3907103	Marine STEYR with CAN Line protocol	AM32
REC3907642	YANMAR MARINE CAN CABLE	AM33



REC3902960

REC39003502

REC39004778



REC3907103



REC3907642

## KIT DIAGNOSIS Y REPROGRAMACIÓN DE LLAVE CABLE KIT FOR DIAGNOSIS AND KEY REPROGRAMMING KIT PER LA DIAGNOSI E RIPROGRAMMAZIONE DI CHIAVE

Ref.

CABLE  
WIRE  
CAVI

REC3906015 BRP Group

3151/AP43



## PUNTAS DE DERIVACIÓN REFERRAL POINTS PUNTA DI DERIVAZIONE

Ref.

CABLE  
WIRE  
CAVI

REC3904048 AM10



Puede utilizarse con interface AM01 o AM01CAN dependiendo de la marca.

It can be used with AM01 or AM01CAN interface depending on the brand.  
Può essere utilizzato con l'interfaccia AM01 o AM01CAN in base alla marca.



# PINTURAS PARA MOTORES ENGINE SPRAY PAINTS VERNICI PER MOTORI

Ref.	MOTOR ENGINE MOTORE	
GS90037	Evinrude	XP
PS111139	Honda	Gris Beige / Grey / Grigio-Beige (1991)
GS90038	Honda	Gris metalizado / Grey Metal / Grigio metalliz.
GS90023	Honda	Plata met. / Silver Metal / Argento metalliz.
GS90030	Johnson	(1972-90) - (1993+)
GS90026	Johnson	(1981-83)
GS90039	Johnson	Plata metal. / Silver Metal / Argento metalliz.
GS90040	Mariner	
GS90002	Mercury	
GS90049	Parsun	
GS90032	Suzuki	Plateado / Silver / Argento (1983-89)
GS90025	Suzuki	Gris Metal / Grey Metal / Grigio Metalliz. (1989)
GS90042	Suzuki	Negro metal. / Black Metal / Nero Metalliz.
GS90024	Tohatsu	Gris Metal / Grey Metal / Grigio Metalliz.(1991)
GS90027	Tohatsu	Cobalto / Cobalt / Cobalto (1988-90)
GS90043	Tohatsu	
PS114694	Yamaha	Azul Metal / Blue Metal / Blu Metalliz. (1974)
GS90021	Yamaha	(1984+)
GS90020	Yamaha	Azul Origen / Blue Origin / Blue Originale
GS90022	Yamaha	Gris Metal / Grey Metal / Grigio Metalliz. (1994)
PS110485	Yamaha	Gris Capot / Grey Capot / Grigio Capot (1994)
GS90006	Caterpillar	
PS111028	Cummins	
PS111047	Cummins	Blanco hueso / White bone / Bianco osso
PS111035	Detroit Diesel	Plateado / Silver / Argento
PS111091	IVECO / AIFO	
GS90002	Mercuriser	
PS114704	NanniDiesel	Azul Metal / Blue Metal / Blu Metalliz.
PS114709	OMC	Cobra Cola / Cobra Sterndrive / Piede Cobra
GS90041	Onan	Marfil / Ivory / Avorio
PS114699	Perkins	Verde Metal / Green Metal / Verde Metallizzato
PS114700	Perkins	(1983+)
PS114701	Perkins	(1987)
GS90031	Solé Diesel	
PS111044	Volvo	(1995)
GS90034	Volvo	Gris / Grey Aquamatic / Grigio
GS90005	Volvo	(1972+)
GS90007	Volvo	Verde Agua / Green Water / Verde acqua (1972+)
GS90029	Volvo	(1989)
GS90003	Volvo	Gris Metal / Grey Metal / Grigio Metalliz. SX/DPX
GS90004	Yanmar	Gris Metal / Grey Metal / Grigio Metalliz. (1987+)

Sprays de pintura con los colores originales para retoque de los motores fueraborda, interiores, intra-fueraborda y colas fueraborda más usuales. Capacidad: 400ml.

Spray paints with the original colors for maintenance and painting inboards and outboard marine engine as well as stern-drives units.

Bottle: 400ml.

Vernice spray con i colori originali per ritocchi dei motori fuoribordo, entro-bordo, entro-fuoribordo e i piedi.

Capacità: 400ml.

**GOLDENSHIP**



## BARNIZ TRANSPARENTE CLEAR VARNISH VERNICE TRASPARENTE

Ref.	
GS90019	400 ml

**GOLDENSHIP**



## KIT DE PINTURA PAINT KIT KIT DI VERNICE

Ref.	Motor Engine Motore	
PS4688	Mercuriser	
PS4706	Volvo	72
PS4707	Volvo	Verde Agua / Green Water / Verde acqua

Kit de pintura de poliuretano bicomponente, compuesto por pintura base, endurecedor y diluyente. Puede aplicarse a pistola o brocha, sobre metal, poliéster o madera. Por su naturaleza de poliuretano y acrílica es suave y muy resistente a la intemperie. Sus agentes anti-corrosión permiten evitar la aplicación de imprimación salvo en casos de soporte poroso.

Resina de alto poder de estanqueidad evitando la corrosión por porosidad del film. El acabado brillante asegura una gran resistencia a la pérdida de color y al calor (80°).

Rendimiento por un kit: 1 capa = 10 m<sup>2</sup> / 2 capas = 6 m<sup>2</sup>.

Paint kit of two components polyurethane paint. Easy application by brush or air pistol. Its nature polyurethane and acrylic permits apply without primer except on porous surfaces.

Kit di vernice in poliuretano bicomponente, composto da vernice base, indurente e diluente. Si può applicare con pennello o con pistola, indicato per metalli, poliester e legno. Molto resistente alla corrosione e alle intemperie, le sue caratteristiche anti-corrosione, permettono di adoperarla senza l'utilizzo del primer, eccetto in casi di materiale poroso.

Resina ad alto potere di impermeabilità, evita la corrosione per porosità.

La finitura lucida assicura una grande resistenza alla perdita di colore.

Rendimiento per un kit: 1 mano = 10 m<sup>2</sup> / 2 mani = 6 m<sup>2</sup>

*Supermarine*



## IMPRIMACIÓN PARA MOTORES PRIMER FOR ENGINES PRIMER PER MOTORE

Ref.	
GS90001	400 ml
GS90012	400 ml

Sprays de imprimación base, para la posterior aplicación de las pinturas.

Primer in spray as base for engine paints.

Spray primer base, per la successiva verniciatura.

**GOLDENSHIP**



## IMPRIMACIÓN PARA COLAS PRIMER FOR STERNDRIVES PRIMER PER PIEDI

Ref.			
SED4610100		250 cc	
SED4610101		500 cc	
SED4610102		2.500 cc	

Gran adhesion sobre acero inox, bronce, aluminio, etc. Aplicación a brocha o rodillo. Para utilizar previo al Velox. Utiliza el diluyente N°4. Metal primer with excellent adhesion on al metals, stainless steel, bronze, aluminum, etc. To be used before Velox. Uses thinner N°4.

Primer per metalli. È dotato di grande adesione su acciaio inox, bronzo e alluminio. Diluente N° 4, applicazione a pennello o a rullo.



MARLIN

Ref.			
SED4612903		250 cc	
SED4612902		500 cc	
SED4613003		250 cc	
SED4613002		500 cc	
SED4613103		250 cc	
SED4613102		500 cc	
SED4613125		2.500 cc	
SED4613403		250 cc	
SED4613402		500 cc	



MARLIN

Antifouling especial para ejes, hélices y colas. Protección extra para las partes metálicas permanentemente sumergidas. No se degrada con la corriente galvánica. Utiliza el diluyente N°4. Antifouling specific for submersed metal parts, as shafts, propellers and stern-drives. It's not degraded by galvanic currents. Uses thinner N°4. Antivegetativa per assi, eliche e piedi. Protezione extra per le parti metalliche sempre sommerse. Resistente alle correnti galvaniche. Utilizzare con il diluente N°4.

## ANTIFOULING ANTIFOULING ANTIVEGETATIVA

Ref.			
GS90008	<input type="checkbox"/> Transp. / Clear / Trasp.	400 ml	
GS90009	<input type="checkbox"/>	400 ml	
GS90010	<input type="checkbox"/>	400 ml	
GS90011	<input type="checkbox"/>	400 ml	

Antifouling para aplicar sobre colas fueraborda. Antifouling for stern-drives.

Antivegetativa spray universale per applicazioni in tutti i piedi fuoribordo.

GOLDENSHIP



## DILUYENTE PARA ANTIFOULING THINNER FOR ANTIFOULINGS DILUENTE PER ANIVEGETATIVA

Ref.			
SED4617201	N° 4	500 cc	
SED4617101	N° 2	500 cc	

MARLIN



## MANTENIMIENTO MOTORES ENGINE MAINTENANCE MANUTENZIONE MOTORI

### PROTECTOR DIELECTRICO DIELECTRIC PROTECTOR PROTETTORE DIELETRICO

Ref.		
GS90092		400 ml

Protector dieléctrico antihumedad para uso marino. Protege de la humedad y oxidación todos las partes eléctricas y mecánicas de los motores marinos. Ideal para invernaje de motores y mantenimiento de temporada.

Prevents humidity and corrosion of all electric and mechanical parts in marine engines. Specially indicate for winter storages and maintenance in the season.

Protettore dielettrico antiumidità per uso marino. Protegge dall'umidità e dall'ossidazione tutte le parti elettriche e meccaniche dei motori marini. Ideale per invernaggio dei motori e manutenzione di lunga durata.



GOLDENSHIP

### PROTECTOR DE MOTOR ENGINE PROTECTOR PROTETTORE MOTORE

Ref.		
GS90090		500 ml

Producto a base de aceites y grasas que protege del óxido y la corrosión las superficies exteriores y partes eléctricas de los motores durante el invernaje. Evita la formación de agarrotamientos debido a la presencia de salitre. Facilita el arranque eliminando los residuos de agua y humedad. Se elimina fácilmente.

Oil & grease made, protects from rust & corrosion external engine surface during winter storage. Removes salt deposit and loosens rusted parts. Easy to remove. Prodotto a base di olio e grasso che protegge dall'ossidazione e dalla corrosione le superfici esterne e le parti elettriche dei motori durante l'invernaggio. Evita la formazione dell'ossidazione dovuta alla presenza del salmastro. Facilita l'accensione eliminando i residui di acqua e umidità. Si elimina facilmente.



GOLDENSHIP

## ESTABILIZADOR DE GASOLINA FUEL STABILIZER STABILIZZATORE BENZINA

Ref.	PARA TRATAR TREAT UP PER TRATTAMENTO
GE22207	475 ml 150 l.

**Para todos los motores de gasolina.** Elimina el agua, limpia los carburadores e inyectores. Contiene antioxidantes para prevenir el óxido y la corrosión. No requiere vaciar el depósito para el invierno y mantiene el combustible fresco para un rápido y fácil arranque.

**For all gasoline engines.** Keeps fuel fresh and allows for easier starts after periods of storage. Removes water, cleans carburetors and fuel injectors. Contains antioxidant to prevent rust and corrosion.

**Per tutti i motori a benzina.** Elimina l'acqua, pulisce i carburatori e iniettori. Contiene antiossidanti per prevenire l'ossidazione e la corrosione. Non è necessario svuotare il serbatoio per l'invernaggio, mantiene il carburante fresco per una rapida e facile partenza.



## ADITIVO GASOLINA GASOLINE ADDITIVE ADDITIVO BENZINA

Ref.	PARA TRATAR TREAT UP PER TRATTAMENTO
STA93008	237 ml 475 l.
STA93016	473 ml 950 l.

Elimina y previene los problemas del ethanol. Reduce todas las emisiones contaminantes. Estabiliza la química del combustible durante 1 año. Reduce el mantenimiento del sistema de combustible. Elimina la producción de carbonilla. Reduce el consumo de combustible.

Eliminates and prevents ethanol fuel problems. Reduces all emissions. Prevents fuel oxidation and stabilizes fuel chemistry for at least 1 year. Lower fuel system maintenance. Eliminates carbon build-up. Increases fuel economy.

Elimina e previene i problemi dell'etanolo. Riduce tutte le emissioni contaminanti. Stabilizza la chimica del combustibile per 1 anno. Elimina la produzione di residui carboniosi. Riduce il consumo del combustibile.



## ESTABILIZADOR DE DIESEL DIESEL STABILIZER STABILIZZATORE DIESEL

Ref.	PARA TRATAR TREAT UP PER TRATTAMENTO
GE22254	946 ml 1.200 l.

**Para todos los motores diesel.** Ayuda a eliminar el agua que las bacterias, hongos y algas necesitan para crecer. Previene la formación de lodos y sedimentos. Limpia y lubrica. Protege contra la corrosión. Reduce la oxidación del gasoil por cambios bruscos de temperatura. Mantiene el gasoil fresco para un rápido y fácil arranque.

**For all diesel engines.** Keeps diesel fresh and allows for easier starts after periods of storage. Prevent sludge and sediment formation. Clean and lubricate. Protect against rust and corrosion. Reduces oxidation of diesel fuel caused by thermal breakdown.

**Pertutti i motori diesel.** Favorisce l'eliminazione delle particelle d'acqua che tendono a crearsi nei serbatoi, e pertanto riduce in maniera decisiva batteri funghi ed alghe. Previene la formazione di sedimenti. Pulisce e lubrifica. Protegge contro la corrosione. Mantiene stabili i valori del gasolio a distanza di tempo.



## ADITIVO DIESEL DIESEL ADDITIVE ADDITIVO DIESEL

Ref.	PARA TRATAR TREAT UP PER TRATTAMENTO
STA93116	473 ml 1.900 l.

Reduce todas las emisiones contaminantes. Estabiliza la química del combustible durante 2 años. Reduce el mantenimiento del sistema de combustible. Elimina la producción de carbonilla. Reduce el consumo de combustible. Cumple las normas de reducción de sulfuro en motores diesel. Reduces all emissions. Stabilizes fuel chemistry for at least 2 years. Lower fuel system maintenance. Eliminates carbon build-up. Increases fuel economy. Meets low sulfur requirements for diesel engines.

Riduce le emissioni del gas. Stabilizza la chimica del combustibile per due anni. Elimina la formazione di fuliggine e riduce i consumi. Soddisfa le norme di riduzione del solfato nei motori diesel.



## ACEITE DE INVERNAJE FOGGING OIL OLIO INVERNAGGIO

Ref.	PARA TRATAR TREAT UP PER TRATTAMENTO
STA84800	3,8 l.
GE22001	340 g

Para inyectar en los carburadores de motores a 2 y 4 tiempos. Protege las paredes de los cilindros, aros de pistones y otras superficies de la cámara de combustión durante los periodos de invernaje, facilitando el arranque posterior del motor.

Prevents corrosion when storing inboard or outboard engines for an extended period of time. Special formula makes starting engine after storage quick and easy.

Da inserire nei carburatori dei motori da 2 e 4 tempi. Protegge le pareti dei cilindri, le fasce dei pistoni e altre superfici della camera di combustione durante il periodo di invernaggio, facilitando la partenza del motore dopo questo periodo.



STA84800



## LIMPIADORES CLEANERS PULITORE

### LIMPIADOR CARBURADOR Y STARTER CARBURATOR & CHOKE CLEANER PULITORE CARBURATORE

Ref.	PARA TRATAR TREAT UP PER TRATTAMENTO
GEGC15	354 g

Aerosol para motores de 2 y 4 tiempos. Para limpieza del carburador y de los componentes internos del motor. Asegura arranques fáciles y ralenti suave. Despega los aros de los pistones. Restablece la potencia del motor. Spray for all 2 and 4 cycle engines. Marine motor de-carb. Dissolves gum, varnish dirt and carbon deposits. Restore power & performance. Reduce fuel consumption.

Aerosol per motori di 2 e 4 tempi. Per la pulizia del carburatore e dei componenti interni del motore. Assicura partenze più facili e un minimo stabile. Lubrifica le fasce dei pistoni. Ristabilizza la potenza del motore.



## LIMPIADOR DEPOSITOS FUEL TANK CLEANER PULITORE SERBATOI

Ref.	PARA TRATAR TREAT UP PER TRATTAMENTO
STA93664	1,9 l. 950 l.



Excepcionalmente efectivo en la limpieza de lodos y algas en depósitos de gasolina o diesel. Retrasa la formación de nuevas algas que puedan contaminar el combustible. Nuevo y revolucionario aditivo que reemplaza los costosos sistemas de limpieza de los depósitos de combustible.

Exceptionally effective at cleaning sludge and algae from gasoline and diesel tanks. Slows the recurrence of new algae that can contaminate fuel. A revolutionary new additive that replaces expensive fuel polishing and tank cleaning.

Eccezionale efficacia nella pulizia dal fango e alghe nel serbatoio benzina o diesel. Ritarda la formazione di nuove alghe che possono contaminare il combustibile. Nuovo e rivoluzionario additivo che rimpiazza i costosi sistemi di pulizia dei serbatoi del carburante.



## LIMPIADOR INYECTORES Y CARBURADORES GASOLINA CARBURATOR & FUEL INJECTOR CLEANER PULITORE INIETTORI E CARBURATORI

Ref.	PARA TRATAR TREAT UP PER TRATTAMENTO	MOTOR ENGINE MOTORI
GE21204	355 ml	Gasolina / Gasoline / Benzina
GE15210	355 ml 130 l.	Diesel

Mejora la potencia y aceleración. Lubrifica todo el sistema de combustible. Maximiza el ahorro de combustible. Alarga la vida de los inyectores.

Improves power and acceleration. Lubricates entire fuel system. Maximizes fuel economy. Extends life of injectors and engine.

Migliora l'accelerazione. Lubrifica tutto il sistema di combustione. Allunga la vita degli iniettori.



GE21204

GE15210



## LUBRICANTES LUBRICANTS LUBRIFICANTI

### ACEITE 2 STROKES TC-W3 2-STROKE TC-W3 OIL OLIO 2 STROKES TC-W3

Especialmente formulado para motores marinos de 2 tiempos. Inhibidor de corrosión y herrumbre. Gran capacidad de limpieza de las partes internas del motor (pistón, bujías...), evita el pegado de segmentos y la formación de depósitos. Alta fluidez a bajas temperaturas.

Niveles de calidad: **NMMA TC-W3** (Asociación General de Constructores Marinos)

Specially formulated for 2-stroke marine engines. Excellent anti-wear protection for the internal parts of the engine. When the engine is not in use, it effectively protects from corrosion and rust. Very effective in maintaining the internal parts of the engine (pistons, spark plugs, etc.) clean, avoiding piston rings from sticking and sediments accumulating.

Quality levels: **NMMA TC-W3** (National Marine Manufacturers Association)  
Formulazione specificamente studiata per motori marino a 2 tempi. Eccellente protezione contro l'usura dei componenti interni del motore. Garantisce un'alta protezione contro la corrosione e la ruggine. Contribuisce in maniera significativa a mantenere pulite le parti interne del motore (pistone, candela, ecc.), evita l'aderenza delle fasce del pistone e la formazione di depositi. Alta fluidità a basse temperature.

Livello di qualità: **NMMA TC-W3** (Associazione statunitense dei produttori per la nautica)



Ref.	1 L	5 L
REC2TU6	6	
REC2TU3		3



### ACEITE 100% SINTÉTICO SAE 5W40 100% SYNTHETIC OIL OLIO 100% SINTETICO

Lubricante marino 100% sintético. Excelente fluidez en frío, facilita el arranque y reduce los desgastes de motor. Evita el pegado de segmentos al dispersar lodos, barnices y otros productos de oxidación a altas temperaturas. Contiene inhibidores antiherrumbre y anticorrosión.

100% synthetic lubricant designed for all types of 4T petrol engines. Good fluidity in cold temperatures facilitates performance and reduces engine wear. It avoids piston rings from sticking by clearing dirt, varnish and other oil oxidation deposits when subject to high temperatures. Contains effective anti-rust and anti-corrosion inhibitors that protect the engine in the marine environment.

Lubrificante 100% sintético pensato per motori a benzina 4T di ogni tipo. Buona fluidità a freddo, facilita la messa in moto e riduce l'usura del motore. Evita l'aderenza delle fasce del pistone, disperdendo fanghi, lacche e altri prodotti derivanti dall'ossidazione dell'olio ad alte temperature. Contiene efficaci inibitori antiruggine e anticorrosione, per proteggere il motore in ambiente marino.



Ref.	1 L	5 L
REC5W40U6	6	
REC5W40U3		3



**MULTIGRADE HIGH PERFORMANCE  
SAE 15W40**



Lubricante multigrado marino, superior al nivel SHPD, especialmente formulado para motores marinos turboalimentados. Contiene inhibidores de corrosión, oxidación, herrumbre y antiespumantes. Capacidad detergente, reduce los depósitos en válvulas y pistones. Excelentes cualidades dispersantes antilodos.

Marine multigrade oil, exceeds the SHPD performance level, especially formulated to meet the demanding requirements of 4-stroke diesel turbocharged engine manufacturers in the marine environment. Contains effective corrosion, oxidation, rust and foam inhibitors. Avoids the need to clean the cylinder liners, typical of powerful supercharged engines. Excellent detergent effect that reduces sediments in valves and pistons. Very good dispersion qualities that prevent sludge in cold temperatures.

Olio marino multigrado, con prestazioni oltre il livello SHPD, specificamente formulato per soddisfare le particolari esigenze dei motori diesel a 4 tempi turboalimentati in ambiente marino. Contiene efficaci inibitori contro corrosione, ossidazione, ruggini e formazione di schiuma. Evita la lucidatura delle camicie dei cilindri tipica dei motori sovralimentati di alta potenza. Eccellente capacità detergente, riduce i depositi in valvole e pistoni. Ottime qualità disperdenti che impediscono la formazione di fanghi a freddo.



Ref.		
REC15W40U3	5 L	3



**ACEITE SINTÉTICO 4 TIEMPOS SAE 25W40  
4 STROKES SYNTHETIC OIL  
OLIO SINTETICO 4 TEMPI**



Lubricante semisintético para motores con cargas y RPM elevadas. Excelentes inhibidores de corrosión, oxidación y desgaste. Buenas propiedades de arranque en frío, antiespumantes incorporados.

Semi-synthetic oil for 4-stroke engines suitable for engines with high RPM and heavy loads. Lubrication of all engine components, great anti-corrosion, anti-oxidation and anti-wear properties. Good performance in cold conditions. Keeps the engine clean and increases protection against corrosion in saline water environments.

Olio semisintetico per motori a 4 tempi, adatto a motori con elevati RPM e carichi pesanti. Conforme alle norme definite dalla NMMA per i nuovi motori. Lubrificazione di tutti i componenti del motore, elevate proprietà anticorrosione, antiossidazione e antiusura. Buone proprietà di avvio a freddo. Mantiene pulito il motore e aumenta la protezione contro la corrosione in acqua salata.



Ref.		
REC25W40U3	5 L	3



**ACEITE SINTÉTICO PREMIUM SAE 10W30 / 10W40  
SYNTHETIC PREMIUM OIL  
OLIO SINTETICO PREMIUM**



Lubricante marino reforzado con bases sintéticas, para motores gasolina 4T fueraborda e intraborda. Especificaciones NMMA FC-W. HTHS elevado, asegura viscosidad a elevadas temperaturas. Anticorrosivo con antioxidantes incorporados, elevadas propiedades antiespumantes.

Marine lubricant strengthened with a synthetic base, especially formulated for outboard and inboard 4T petrol engines, with NMMA FC-W specifications. With a high HTHS, it ensures great viscosity at high temperatures.

Better anti-oxidant resistance. Improved anti-foaming properties. Lubrificante marino potenziato con basi sintetiche, specificamente formulato per motori a benzina 4T fuoribordo ed entro bordo, a norma specifiche NMMA FC-W. Con indice HTHS più elevato, garantisce un'alta viscosità a temperature elevate. Aumenta la protezione anticorrosione. Maggior resistenza all'ossidazione. Proprietà antischiuma migliorate.



Ref.		
REC10W30U6	1 L	6
REC10W30U3	5 L	3
REC10W40U6	1 L	6
REC10W40U3	5 L	3



## ACEITE ATF. TRANSMISIÓN AUTOMÁTICA ATF FLUID. AUTOMATIC TRANSMISSION OLIO ATF. TRASMISSIONE AUTOMATICA



Fluido hidráulico marino sintético tipo ATF. Especialmente indicado para transmisiones automáticas, servomecanismos y direcciones asistida. Formula sintética de elevada viscosidad, incorpora anticorrosivos y antiespumantes.

ATF synthetic hydraulic fluid. Especially suited for automatic transmissions, servo-devices, power-assisted steering.

Great anti-wear properties that prolong the life of the mechanism. Great anti-ageing properties and prevents deposit formation. Provides a smooth performance without transmission knocks. Provides high protection against corrosion and excellent fluidity at low temperatures. Prevents foaming and provides rubber seal stability.

Fluido idraulico sintético de tipo ATF. Specificamente indicato per trasmissioni automatiche, servomeccanismi, servotimoni.

Eccellente trasmissione di potenza, formula sintetica ad alta durata. Alta capacità antiusura, per prolungare la vita utile dei meccanismi. Alta resistenza all'invecchiamento e alla formazione di fanghi. Garantisce un funzionamento fluido e senza scatti della trasmissione. Alta protezione contro la corrosione ed eccellente fluidità a basse temperature. Bassa formazione di schiuma e stabilità in presenza di guarnizioni di gomma.



Ref.		
RECATFU3	5 L	3

**NEW**

## ACEITE PARA TRANSMISIÓN IPS SAE 75W90 OIL FOR IPS TRANSMISSION OLIO PER TRASMISSIONE IPS



Lubricante marino sintético GL-5 para transmisiones IPS y reductoras. Soporta elevadas temperaturas internas sin descomponerse así como cargas considerables sin causar desgaste. Excelente protección a cualquier temperatura.

GL-5 synthetic oil of the highest quality for marine drives and IPS transmissions. It can also withstand very high temperatures without breaking down. Withstands heavy loads preventing wear.

Olio sintetico GL-5 di altissima qualità per s-drive, trasmissioni IPS e riduttori. In quanto olio sintetico, garantisce un'eccellente protezione a basse ed elevate temperature. Può inoltre sostenere altissime temperature senza decomorsi. Sostiene carichi considerevoli senza provocare usura.



Ref.		
REC75W90U6	1 L	6
REC75W90U3	5 L	3

**NEW**

## ACEITE PARA TRANSMISIÓN SAE 80W90 OIL FOR TRANSMISSION OLIO PER TRASMISSIONE



Lubricante marino para transmisiones de motores intraborda y fueraborda de los principales fabricantes, que requieren aceites con una calidad API GL 5. Consulte el manual de usuario antes de elegir el lubricante.

GL-5 synthetic oil of the highest quality for marine drives and IPS Oil recommended for the transmission of inboard and outboard engines of the main manufacturers that require API GL 5 quality oils. Read the user manual before choosing a lubricant.

Olio sintetico GL-5 di altissima qualità per s-drive, trasmissioni IPS e riduttori. Olio consigliato per trasmissioni entro bordo e fuoribordo dai principali produttori che richiedono oli di qualità API GL 5. Consultare il manuale d'uso prima di scegliere il lubrificante.



Ref.		
REC80W90U3	5 L	3

**NEW**

## ACEITE PARA TRANSMISIÓN SAE 75W140 OIL FOR TRANSMISSION OLIO PER TRASMISSIONE



Lubricante marino de alto rendimiento para transmisiones. Excelentes prestaciones que evitan el desgaste y presiones extremas, la temperatura ambiente y condiciones de trabajo no alteran su capacidad lubricante. High performance oil designed for marine transmissions. Excellent performance that prevents wear and extreme pressure, providing maximum protection to the transmission; temperatures and working conditions do not alter its lubricating effect.

Olio ad alto rendimento per trasmissioni nautiche. Eccellenti prestazioni che evitano usura e pressioni estreme, garantendo la massima protezione della trasmissione; la temperatura ambiente e le condizioni di lavoro non ne modificano le proprietà lubrificanti. Temperatura e rumore ridotti grazie alla riduzione dell'attrito.



Ref.		
REC75W140U3	5 L	3



## ACEITE SINTÉTICO 2 TIEMPOS 2 CYCLE SYNTHETIC OIL OLIO SINTETICO 2 TEMPI

Ref.	R.O. OEM		
RM92-858026QB1U6	92-858026QB1	1 l.	6
RM92-858027QB1U3	92-858027QB1	3,8 l.	3
RM92-858037QB1U3	92-858037QB1	3,8 l.	3

### Premium Plus

El uso continuo del aceite para motores fueraborda de 2 tiempos ayudará a reducir la corrosión y la acumulación de carbón, a la vez que proporciona una lubricación superior a los componentes internos del motor.

Continued use of 2-cycle outboard oil will help reduce corrosion and carbon build-up while providing superior lubrication for internal engine components.

L'uso continuato di olio per motori fuoribordo a 2 tempi riduce la corrosione e i depositi di carbonio fornendo nel contempo lubrificazione eccellente ai componenti interni del motore.



RM92-858026QB1U6

RM92-858027QB1U3



RM92-858037QB1U3

Aceite de mezcla para motores tipo OPTIMAX / DFI.

Oil for engines type OPTIMAX / DFI.

Olio miscela per motori tipo OPTIMAX / DFI.

## ACEITE 4 TIEMPOS 4-STROKE OIL OLIO 4 TEMPI

Ref.	R.O. OEM	SAE		
RM92-8M0086220U6	92-8M0086220	10W-30	1 l.	6
RM92-8M0086221U3	92-8M0086221	10W-30	3,8 l.	3
RM92-8M0086227U3	92-8M0086227	25W-40	3,8 l.	3



RM92-8M0086220U6

RM92-8M0086221U3

RM92-8M0086227U3

### SAE 25W-40

Aceite sintético para motores tipo VERADO.

Synthetic oil for engines type VERADO.

Olio sintetico per motori tipo VERADO..

## ACEITE MOTORES GASOLINA GASOLINE ENGINES OIL OLIO MOTORE BENZINA

Ref.	R.O. OEM	SAE		
RM92-8M0086224U3	92-8M0086224	25W-40	3,8 l.	3





## ACEITE MOTORES DIESEL DIESEL ENGINES OIL OLIO MOTORE DIESEL

Ref.	R.O. OEM	SAE		
RM92-8M0096794U3	92-8M0096794	15W-40	3,8 l.	3



## ACEITE HIGH PERFORMANCE HIGH-PERF GEAR LUBE OLIO HIGH PERFORMANCE

Ref.	R.O. OEM	SAE		
RM92-858064QB1U6	92-858064QB1	90W	1 l.	6
RM92-858065QB1U2	92-858065QB1	90W	9,5 l.	2

Aceite **sintético** de altas prestaciones. Para colas de transmisión mecánica.  
High performance **synthetic** Lower Unit Gear Lube for mechanical drives.  
Olio **sintético** di alta prestazione. Per piedi poppieri a trasmissione meccanica.



RM92-858064QB1U6



RM92-858065QB1U2

## ACEITES SINTÉTICOS SYNTHETIC OILS OLIO SINTETICO

Ref.	SAE		
LUB11564U12	80W 90	1 l.	12
LUB11565	80W 90	19 l.	1

Especialmente indicados para los motores de gran cilindrada o de uso frecuente. Reduce el grado de fricción y calentamiento. No se mezcla con el agua. No anula las garantías de los fabricantes.

A synthetic gear lube that protects high-performance lower units in extreme operating conditions. Highly recommended for all engines over 100 hp. Will not avoid manufacturers' warranties.

Indicato specialmente per motori di grande cilindrada o di uso frequente. Riduce il grado di attrito e riscaldamento. Non si mescola con l'acqua. Non annulla la garanzia del produttore.





LUB11564U12



LUB11565

## ACEITE TRIM / TILT POWER TRIM & TILT FLUID OLIO TRIM / TILT



Ref.			
LUB11578U12	280 g.	12	

Proporciona la viscosidad y lubricación necesaria para asegurar el perfecto funcionamiento de la bomba alargando la vida de los retenes y juntas. Power Trim & Tilt fluid. Formulated to provide viscosity and lubricity necessary to ensure proper pump performance and seal life.

Fornisce la viscosità e la lubrificazione necessaria per assicurare il perfetto funzionamento della pompa allungando la vita delle guarnizioni.



## ACEITE MINERAL FUERABORDAS 2-CYCLE OIL OLIO MINERALE PER FUORIBORDO

Ref.	R.O. OEM		
LUB11591U12		1 l.	12
LUB11592		3,8 l.	1
LUB11593		9,5 l.	1
RM92-858021QB1U6	92-858021QB1	1 l.	6
RM92-858022QB1U3	92-858022QB1	3,8 l.	3
RM92-858023QB1U2	92-858023QB1	9,5 l.	2

El nuevo aceite anticarbonilla **TC-W3** supera todos los requerimientos de garantía que los fabricantes de motores exigen. Utilice el **TC-W3** para obtener mayor potencia en su motor. Provee de una mayor protección contra la carbonilla en los pistones, el resacamiento de los aros, el fallo de las bujías en el arranque y del óxido. **Recomendado para los sistemas de inyección de aceite.**

Formulated from ultra-clean base stock oil to provide superior protection against piston scuffing, bearing wear, spark plug fouling, pre-ignition and rust. This formulation has outstanding lubricity and miscibility for better mixing of fuel and oil, resulting in a cleaner running engine. Contains no phosphorus. **Recommended for oil injection systems.** Outboard motor Oil.

Il nuovo olio anticarbon TC-W3 supera tutti i requisiti di garanzia che i produttori di motori esigono. Utilizzare il TC-W3 per ottenere maggior potenza nel motore. Fornisce una maggiore protezione contro i residui di combustione nei pistoni, l'essiccazione delle fasce, il non funzionamento delle candele nell'accensione. **Raccomandato per i sistemi di iniezione ad olio.**



LUB11591U12



LUB11592



LUB11593



RM92-858021QB1U6



RM92-858022QB1U3



RM92-858023QB1U2





**KIT ACEITE COLAS  
LOWER UNIT LUBE KIT  
KIT OLIO PIEDI**

Ref.	
LUB11101	285 g.

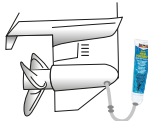
Kit para cambiar el aceite mineral de las colas. Includes 2 tubes of high-viscosity lower unit gear lube.  
Kit per cambiare l'olio minerale dei piedi poppieri



**ACEITE MINERALES  
MINERAL GEAR OILS  
OLIO MINERALE**

Ref.	SAE		
LUB11540U12	80W 90	290 g	12
LUB11552U12	80W 90	1 l.	12
LUB11546	80W 90	19 l.	1



Para colas de transmisión mecánica. Especialmente indicados para los motores de gran cilindrada o de uso frecuente. Fabricado con aditivos especiales para proveer una máxima durabilidad e inhibidores de la corrosión para una mayor protección contra el óxido y la corrosión.

Lower Unit Gear Lube for mechanical drives. Lower Unit Gear Lube. Ideal for modern outboard and stern drive lower units. Will not void manufacturers' warranties.

Per piedi poppieri a trasmissione meccanica. Indicato specialmente per motori di grande cilindrata o di uso frequente. Fabbricato con additivi speciali per fornire una massima durata e impedire la corrosione per una maggiore protezione contro l'ossidazione e la corrosione.



LUB11540U12





LUB11552U12



LUB11546

**GRASA MARINA  
MARINE GREASE  
GRASSO MARINO**

Ref.	PISTOLA GUN PISTOLA		
LUB11400	RECT30190	85 g	4
LUB11402	RECT30201	400 g	1
LUB11406	LUB30197	280 g	1
LUB11407		13,5 kg	
LUB11404		450 g	



Lubricante insoluble al agua, ideal para aplicaciones marinas. Excelente protección contra fricciones, óxido y corrosión.

Special calcium sulfonate complex, water insoluble formula ideal for marine applications. Provides excellent corrosion protection under severe conditions caused by salt water and air.

Lubrificante insolubile all'acqua, ideale per applicazioni marine. Eccellente protezione contro l'attrito, l'ossido e la corrosione.

LUB11400



LUB11407

LUB11404



LUB11402



LUB11406



**GRASA MARINA. INSOLUBLE AL AGUA  
MARINE GREASE. NON-WATER-SOLUBLE  
GRASSO MARINO. INSOLUBILE IN ACQUA**



Grasa marina semisintética con base de litio-calcio, de cuerpo espeso y color azul. 100% insoluble al agua, especialmente formulada para todo tipo de aplicaciones náuticas incluso prensaestopas y hélices plegables, gracias a la buena adhesión al metal.

Semi-synthetic marine grease with a lithium and calcium base, thick and blue. 100% non-water-soluble, especially formulated for all nautical uses, including cable glands and foldable propellers, thanks to good adherence to metal.

Grasso marino semisintetico a base di litio-calcio, di aspetto denso e di colore azzurro. 100% insolubile in acqua, specificamente formulato per applicazioni nautiche di tutti i tipi, compresi premistoppa ed eliche pieghevoli, grazie all'alta aderenza ai metalli.

Ref.		
RECGREU1	5 Kg	1
RECGREU12	400 g	12



## GRASA DE LITIO LITHIUM GREASE GRASSO AL LITIO

Ref.   
LUB11363 350 ml

Grasa de litio con Teflón. Color blanco. Contiene aditivo de cinc para facilitar la limpieza y engrase. Heavy duty white lithium grease with Teflon. Contains zinc additive to facilitate cleaning and lubrication.  
Grasso al litio con Teflón. Colore bianco. Contiene zinco per facilitare la pulizia e oliatura.



## HERRAMIENTAS TOOLS ATTREZZI

### KIT PISTOLA + GRASA MIDGET GREASE GUN KIT KIT PISTOLA + GRASSO

Ref.   
RECT30190 1

Kit compuesto de una pistola pequeña y muy versátil que permite la salida del tubo conector frontal o superior. Presión máxima 300 k/cm<sup>2</sup>. Incluye un bloqueador para mantener el cartucho en posición y tubo de salida de 14 cm. Admite cartuchos de 3 onzas (85 g) o grasa a granel. Marine corrosion control lubrication kit. Small, versatile gun allows for front or top pipe placement. Barrel takes 3 oz. grease cartridge or can be bulk loaded. Develops up to 4,500 psi.

Kit composto da una pistola piccola e molto versatile che permette l'uscita del grasso dal tubo frontale o superiore. Pressione massima 300 k/cm<sup>2</sup>. Include un blocco per tenere la cartuccia in posizione, il tubo è da 14 cm. Utilizza cartuccia da 85 gr. o grasso sfuso.

**RECMAR**



Ref.   
LUB30197 1

Pistola para tubos de grasa. Incluye manguera flexible de 14 cm y adaptador standard.

All purpose gun operates handy squeeze tubes. Includes 2-11/16" pipe and plastic push-type coupler.

Pistola per tubi di grasso. Include tubo flessibile da 14 cm e adattatore standard.



## PISTOLAS DE GRASA LEVER GREASE GUNS PISTOLE GRASSO

PISTOLA GUN MANGUERA 30 cm  
PISTOLA HOSE 30 cm  
RECT30201 TUBO 30 cm  
RECT10212

Pistola de grasa. Capacidad: 600 cc. Incluye manguera curvada y conector standard. Presión máxima 16.000 psi. Ideal para engrasar crucetas, cables de dirección, cañas de motor fuerborda, piñones y cualquier otra parte del motor que precise engrase.

Standard Lever grease gun. Capacity: 600 cc. Includes curved pipe and std. coupler. The Max pressure for grease gun is 16000psi. Ideal for greasing spreaders, steering wires, rods outboard engine, gear bearing and other parts of the engine that needs greasing.

Pistola di grasso. Capacità 600 cc. Include tubo flessibile curvo e connettore standard. La pressione massima della pistola è 16000psi. Ideale per ingrassare cavi dello sterzo, barre del motore fuorbordo, ingranaggi e qualsiasi altra parte del motore che abbia bisogno di lubrificazione.

**RECMAR**

RECT30201



RECT10212

### KIT ENGRASADORES METRIC GREASE FITTINGS KIT LUBRIFICATORI

Ref.   
LUB11957 8

Kit compuesto por 8 engrasadores métricos de 6 mm (4 rectos, 2 de 45° y 2 de 90°).

Includes eight 6mm metric fittings: 4 straight, 2 of 45° and 2 of 90°.

Kit composto da 8 lubrificatori metrici da 6 mm (4 dritti, 2 da 45° e 2 da 90°).

**LUBRIMATIC**



Ref.   
RECT11958 4

Kit de 4 engrasadores métricos de 6 mm de 90°.

Includes four 6 mm metric fittings of 90°.

Kit composto da 4 lubrificatori metrici da 6mm da 90°.

**RECMAR**



**PISTOLA DE ACEITE  
BOTTLE GREASE PUMP  
PISTOLA OLIO**

Ref.  
**REC55005**



Pistola para acoplar en los envases de botella de 1 l. LUB11552 y LUB11564U12. Se suministra con kit de adaptación con válvula antirretorno. Lower unit quart pump. Complete with metal threaded filler fitting. Pistola da accoppiare a bottiglie da 1 lt. LUB11552 e LUB11564U12. Si vende con kit di accoppiamento con valvola anti-ritorno.



**KIT CAMBIO DE ACEITE  
OIL CHANGE KIT  
KIT CAMBIO OLIO**

Ref.   
**SH8050-305-426** 13 l. 14,1 l/m 12 V / 4,7 A 406 x 318 mm

Bomba reversible, para cambio de aceite instalada sobre un bidón portátil con mangueras de extracción y 2,5 m de cable eléctrico con pinzas. Reversible pump kit for oil change, winterizing and liquid transfer. Hose kit and 3,5 gal. storage container. Pompa reversibile, per cambio dell'olio. Installata sopra un bidone portatile con tubo di estrazione e 2,5 m di cavo elettrico con pinze.



**BOMBA DEPÓSITO ACEITE  
PUMP-TANK PAIL OIL  
POMPA ESTRAZIONE OLIO**

Ref.   
**SSPELO5** 5,5 l.

Sistema completo con un depósito de 5,5 l. Tapa superior con triple función: llenado, varilla nivel y tapón de apretura de seguridad. 2,4 m de manguera de suministro y 2 conectores de motor universales. Llène el depósito con aceite de motor, presurice el tanque con aire (50-100 psi), conecte la manguera al motor, abra la válvula del depósito y en pocos segundos el llenado está realizado.

Comes complete with 5 quart capacity tank, triple purpose top (oil fill/dipstick measure/patented pressure release safety cap) 8 ft. oil supply hose and 2 universal engine connector fittings. Simply fill the tank with engine oil, pressurize tank with air (50-100 psi) connect pre-lube oil supply hose to engine oil sending unit port, open tank flow-control valve, and in just a few seconds pre-lube is complete.

Sistema completo per controllo perdite olio all'interno dei blocchi motore; deposito da 5,5lt fornito di tubo da 2,4 mt con due connettori universali. Riempire il motore con un livello d'olio adeguato, mettere in pressione la pompa (50-100 psi), e collegarla all'attacco del sensore pressione olio. In questo modo si può verificare se il blocco motore presenta perdite.



**BOMBA EXTRACTORA  
LOWER UNIT PAIL PUMP  
POMPA ESTRATTRICE**

Ref.  
**LUB55011**

Bomba extractora para bidones de aceite de 19 litros. LUB11546 y LUB11565. Puede acoplarse directamente a las colas. Se suministra con adaptador roscado para las colas americanas habituales.

For bulk filing of lower units and stern drives. Designed to fit 35lb/5 gal on per pails.

Pompa estrattrice per bidoni d'olio da 19 litri. LUB11546 e LUB11565 Si può collegare direttamente ai piedi. Si vende con adattatori per i piedi poppieri abituali.



**BOMBA DE TRASVASE  
DRILL PUMP  
POMPA TRAVASO**

Ref.   
**SH3010-000** 760 l/h

Bomba extractora de aceite o trasvase de líquidos. Se acopla a los taladros eléctricos con portabrocas de 6 mm. Incluye manguera y tubo para aceite. Ideal for pumping water or oils. Includes 2,4 m hose. Drill shaft: 6 mm.

Pompa estrattrice olio o travaso di liquidi. Si accoppia ai trapani elettrici con morsetti di 6 mm. Incluso tubo dell'olio.



BOMBA GEASECASE POMPA <b>REC55133GF</b>	ADAPTADOR MÉTRICO (NO SUZUKI) METRIC ADAPTOR (NO SUZUKI) ADATTATORE METRICO (NO SUZUKI) <b>REC55133M</b>	ADAPTADOR SUZUKI SUZUKI ADAPTOR ADATTATORE SUZUKI <b>REC5 5133S</b>
--	---	--

Para llenado de colas. Con válvula de ventilación para evitar derrames.

With check valve venting system to avoid overflow. Per mettere l'olio nei piedi poppieri. Con valvola di sfianto per evitare fuoriuscite.



REC55133M



REC55133S



## EXTRACTORES DE ACEITE MANUALES OIL MANUAL EXTRACTORS POMPA OLIO MANUALE

Ref.

GS20151

Bomba manual para extraer el aceite de motor. Cuerpo de PVC y latón. Incluye tubos de nylon flexible.  
Made of solid brass and PVC. With removable tubing for easy operation and cleaning.

Pompa manuale per estrarre l'olio dal motore. Corpo in PVC e ottone. Include tubi in nylon flessibile.



GOLDENSHIP

Ref.



GS20080	4 l.	2.1 kg	496 x 204 mm
GS20081	6 l.	2.4 kg	648 x 204 mm
GS20082	18 l.	4.9 kg	700 x 350 mm

Incluye 3 tubos de Ø9.8, 6.7 y 5.8 mm. Temperatura máxima 100°C. Cuando está lleno se para automáticamente.  
With 3 tubes: Ø9.8, 6.7 & 5.8 mm. Maximum temperature 100 °C. When full it automatically stops.

Include tubi da: Ø9.8, 6.7 e 5.8 mm. Temperatura massima 100 °C. Quando pieno arresta automaticamente



GOLDENSHIP



GS20080



GS20081



GS20082



NEW

Ref.



GS20084	7 l.
GS20085	9 l.

## SILICONA JUNTAS LIQUID GASKET SILICONE PER GUARNIZIONI

Ref.

STA82910



83 ml

Starbrite



Se utiliza para hacer las juntas de colectores de admisión y cárter. Resiste temperaturas hasta 310°C.

Makes gaskets quickly, easily. For use up to +600°F

Si utilizza per l'installazione delle guarnizioni nei collettori e nella coppe dell'olio. Resistente alle alte temperature fino a 310°C.

## EXTRACTOR FILTROS OIL FILTER WRENCH ESTRATTORE FILTRI

Ref.

REC70720

Llave para filtros de 65 a 110mm.

Filter wrench from 65 to 110mm.

Chiave per filtri da 65 a 110mm.

RECMAR

NEW



## OREJERAS MOTOR FLUSHER CUFFIE LAVAGGIO

Ref.

GS30350	Redondas / Round / Rotonde
GS30352	Cuadradas / Square / Quadrate
GS30351	Redondas / Round / Rotonde
GS30353	Cuadradas / Square / Quadrate

Tomas de agua para refrigeración de motores fueraborda y colas intra-fueraborda.

For use on most outboards and inboard/outboards engines with side water inlets.

Cuffie lavaggio per motori entro-fuoribordo e fuoribordo.

GOLDENSHIP



GS30350

GS30352

Tomas de agua  
Uso profesional.  
Heavy duty motor flusher.  
Cuffie lavaggio  
Uso professionale.

GOLDENSHIP



GS30351

GS30353

**KIT EXTRACTOR DE POLEAS**  
**PULLER TOOL KIT**  
**KIT ESTRATTORE PULEGGE**

Ref. **SSP4600**

Extractor de polea contrapesos. Contiene 5 juegos de tornillos de diferentes medidas.  
Harmonic ballancer puller. 5 sets of screws are provided.  
Estrattore pulegge. Contiene 5 kit di viti di differenti misure.



Ref. **SSPHBP100K**



Kit para extraer e instalar poleas. Para uso en todos los motores Ford, GM y Chrysler. También puede utilizarse para volantes de dirección y poleas en general. Esfuerzo máximo recomendado: 20 kg.  
Harmonic ballancer puller and installation tool kit. Use on all Ford, GM & Chrysler engines. Heavy duty tool. Can also be used for steering wheels and pulleys  
Kit per estrarre e installare pulegge in tutti i motori Ford, GM e Chrysler. Si può utilizzare per volani di direzione e pulegge in generale. Carico massimo: 20 kg.

**EXTRACTOR COJINETES**  
**DRIVER BEARING**  
**ESTRATTORE CUSCINETTI**

Ref. **REC91-34569A1** R.O. **91-34569A1** OEM

**NEW**



**EXTRACTOR IMPULSORES**  
**IMPELLER REMOVAL**  
**ESTRATTORE GIRANTE**

Ref.	Ø	
<b>GS20198</b>	65 mm	2 1/2"
<b>GS20199</b>	77 - 127 mm	3" - 5"

Extractor para impulsores flexibles de bombas, motores fueraborda e interiores.  
Flexible impeller removal tool, suitable for all marine flexible impellers of water pumps, outboard and inboard engines.  
Estrattore per giranti di pompe di motori fuoribordo e entrobordo.

**GOLDENSHIP**

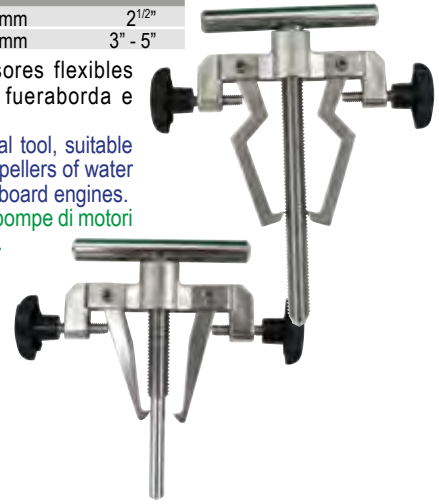

**EXTRACTOR COJINETES Y HÉLICES**  
**PROP AND BEARING PULLER**  
**ESTRATTORE CUSCINETTI E ELICHE**

**RECmar®**

Ref. **REC90095**

Extractor de cojinetes y hélices, con patas. Para todos los cojinetes Mercruiser y la mayoría de las hélices.  
Prop and bearing carrier puller. Capacity: 5 Tons (Min). For Mercruiser All Style Bearing Carrier and Most Props.  
Estrattore cuscinetti e eliche. Per tutti i cuscinetti Mercruiser e la maggior parte delle eliche.



Para hélices y cojinetes antiguos  
For prop and old style bearing carrier.  
Per eliche e cuscinetti vecchi.



Para cojinetes modernos  
For new style bearing carrier.  
Per cuscinetti moderni.

**EXTRACTOR PIÑONES Y COJINETES**  
**UNIVERSAL PULLER PLATE**  
**ESTRATTORE PIGNONE E CUSCINETTI**

Ref.		
<b>REC91-00001</b>	1 1/4" - 2 1/4"	30 - 50 mm
<b>REC91-00002</b>	2 1/4" - 3 1/2"	50 - 75 mm
<b>REC91-37241</b>	3" - 4 1/2"	75 - 105 mm

**NEW**

**RECmar®**



## JUEGO DE MACHOS TAP AND DIE SET FILIERA

Ref.	
CRA952343	Pulgadas Inches Pollici
CRA952344	Métrico Metric Metrico

Garantía de por vida.  
Lifetime warranty.  
Garantita a vita.



## JUEGO DE LLAVES MECHANICAL TOOL SET CASSETTA ATTREZZI

Ref.
CRA935154



154 llaves en métrico y en pulgadas para un completo trabajo en motores.  
Garantía de por vida.  
154 pcs. Mechanics tool set in metric & inches. Lifetime warranty.  
154 chiavi metriche e in pollici per un lavoro completo nel motore. Garantita a vita.

## HERRAMIENTA AROS-PISTONES RING COMPRESOR KIT KIT FASCE-PISTONI

Ref.
SSP4213

Kit herramientas para la instalación de aros y pistones.  
Incluye 6 bandas de 7 a 11 cm.  
Ring compressor kit for pistons.  
Includes 6 band 2-7/8" - 4-3/8"  
Kit per montare le fasce dei pistoni.  
Include 6 bande da 7 a 11 cm.



**RECMAR**

Ref.	PARA AROS Y PISTONES RING COMPRESOR PISTONS PER FASCE E PISTONI
SSP4206	127 mm Ø 2 1/8" - 5"
SSP4207	178 mm Ø 3 1/2" - 7"

**RECMAR**



## KIT LLAVE HÉLICE PROP WRENCH KIT KIT CHIAVE ELICA

Ref.	R.O. OEM	TURECA NUT DADO
REC91-859046Q4	HONDA 89-89206-ZW7-000AH MERCURY 91-821887T1 MCM 91-859046Q4	1 1/16"

Mercury Mariner 75 - 300 HP  
Force V4, V6  
Mercruiser Alpha / Bravo  
Honda BF75-BF130  
Suzuki DF60 - DF225 HP  
Nissan / Tohatsu 70-140 HP  
Yamaha Sterndrives  
Yamaha 50-250 HP  
OMC Cobra / Volvo SX  
Jonhson Evinrude V4 / V6 / V8

**RECMAR**



## LLAVE DINAMOMÉTRICA TORQUE WRENCH CHIAVE DINAMOMETRICA

Ref.
CRA944595



Con escala en 20 - 150 pies/libras y 33.9 - 210 N.m  
Incrementos cada 1 pie/libra y 1,4 N.m  
Dado de conexión: 1/2"  
Dimensiones 518 x 35 x 40 mm  
Scale in 20-150 ft-lbs. 33.9 - 210 N.m  
Increases each 1 ft-lbs. & 1,4 N.m  
1/2" drive.  
Dimensions: 518 x 35 x 40 mm  
Con scala da 20 - 150 piedi /libra e 33.9 - 210 N.m  
Incremento di 1 pie / libra e 1,4 N.m  
Dado attacco: 1/2"  
Dimensione 518 x 35 x 40 mm.

## PULIDORA ENGINE CYLINDER HONE PULITRICE CILINDRI

PULIDORA HONE PULITRICE	KIT RECAMBIO KIT SPARE KIT RICAMBIO
CRA904633	CRA946331

Para pulir los cilindros de los bloques.  
Garantizada de por vida.  
Quickly removes the glaze from engine cylinder walls before installing new piston rings. Lifetime warranty.  
Per pulire i cilindri dei blocchi. Garantita a vita.



CRA946331

**PIEDRAS PULIDORA**  
Kit de 3 piedras para recambio de la pulidora.  
**ENGINE CYLINDER HONE**  
3 pieces spare part for Hone.  
**KIT SPAZZOLE**  
Kit da 3 spazzole di ricambio per la pulitrice.

CRA904633



**CHISPÓMETRO  
SPARK GAP TESTER  
SCINTILLOMETRO**

Ref.	CILINDROS CYLINDERS CILINDRI
REC5119766	8
REC004	1

**RECMAR®**



REC004

REC5119766

Se puede comprobar la chispa con el motor en funcionamiento.  
Good for checking spark on running engine.  
Si può provare la scintilla con il motore in funzione.

**KIT 4 ALARGADORES CABLE BUJÍAS  
EXTENSION 4 WIRES  
KIT 4 PROLUNGA CAVI CANDELE**

Ref.	
REC5119902	18 cm / 7"
REC5119903	60 cm / 24"

**RECMAR®**



REC5119902

REC5119903

**VACUÓMETRO DOBLE FUNCIÓN  
PRESSURE / VACUUM TESTER  
VACUOMETRO DOPPIA FUNZIONE**

Ref.
REC55134

Presión y vacío. Ideal para comprobar las colas.  
Combination unit that does pressure and vacuum testing in one units. recommended to test drives.  
Pressione e sottovuoto. Ideale per il controllo dei piedi.

**RECMAR®**



**HERRAMIENTA VÁLVULA  
VALVE SPRING COMPRESSOR  
ATTREZZO VALVOLE**

Ref.
SSP4265

**RECMAR®**

Herramienta para el montaje y desmontaje de válvulas. Incluye tres juegos de mordazas.  
Manual valve spring compressor. Universal. Includes 3 jaw sets.  
Attrezzo per montare e smontare le valvole. Include 3 kit per misure differenti.



**LLAVE FRENO VOLANTE  
FLYWHEEL HOLDER  
CHIAVE FRENO VOLANTE**

Ref.
REC5515100

**RECMAR®**

Para fuerabordas.  
For outboards.  
Per fuoribordo.



**COMPRESÍMETRO  
COMPRESSION TESTER KIT  
MANOMETRO**

Ref.
CRA902171

Para motores gasolina con bases GM o Ford.  
For gas engines with GM or Ford base.  
Per motori benzina con base GM e Ford.



**INTERRUPTOR ARRANQUE  
REMOTE STARTER  
INTERRUTTORE AVVIAMENTO**

Ref.
CRA902175



## FONENDOSCOPIO SPARK GAP TESTER FONENDOSCOPIO

Ref.  
REC91-00003

**RECMAR®**

Instrumento de precisión, resistente a golpes, detecta fácilmente ruidos en motores, cojinetes y otras partes móviles. Incluye varilla de test, trompeta y auriculares.

Sensitive, shockproof instrument, easily locates noises in engines bearings and other moving parts. Includes aluminium alloy probe, needle, surgical PVC, rubber trumpet and plastic earphones.

Strumento di precisione, resistente a colpi, rileva facilmente rumori nel motore, nei cuscinetti e altre parti mobili. Include la tromba e gli auricolari.

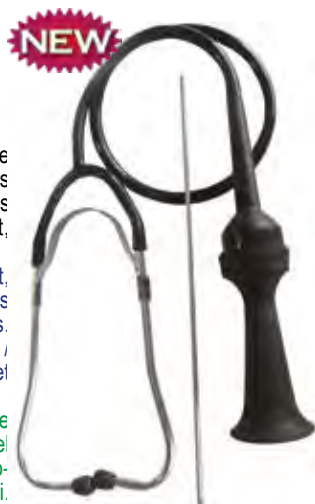

**NEW**

## PISTOLA PUESTA A PUNTO TIMING LIGHT PISTOLA MESSA A PUNTO

Ref.  
CRA921023



Con regulador de avance.  
0-60 advance scale.  
Con regolatore avanzamento.

## TACÓMETRO ÓPTICO OPTICAL TACHOMETER TACOMETRO OTTICO

Ref.  
TEC384

Profesional portátil controlado por microprocesador y con base de tiempos de cristal de cuarzo de gran precisión. Medidor de RPM hasta 99.999.

Precisión: +/- (0,05% + 1 d.)

Resolución: 0,1 (hasta 9.999,9)

Distancia óptima de medida: de 50 a 150 mm. Hasta 300 mm en función de luz ambiente. Retención de la última lectura en pantalla y registro lectura máxima y mínima del periodo de medida.

Professional portable microprocessor-controlled and with time base of quartz crystal of high precision.

RPM meter up to 99,999

Accuracy: +/- (0.05 % + 1 d.)

Resolution: 0.1 (up to 9,999.9)

Optimal distance measure: 50 to 150 mm. Up to 300 mm depending on ambient light. Retention of the latest reading on screen and record the maximum and minimum measurement period.

Professionale portatile controllata da un microprocessore e con display a cristalli di quarzo di alta precisione.

Misura in RPM fino a 99.999.

Precisione: +/- (0,05% + 1 d.)

Risoluzione: 0,1 (fino 9.999,9)

Distanza ottima di misurazione: da a 50 a 150 mm. Fino a 300 mm. Funziona con luce ambiente. Memoria dell'ultima lettura nello schermo e registro lettura massima e minima del periodo di misurazione.



### CINTA REFLECTANTE PARA TACÓMETRO TEC384

REFLECTIVE TAPE FOR TACHOMETER TEC384

BANDA PER TACOMETRO TEC384

Ref.  
TEC786

## MULTITESTER DIGITAL DIGITAL MULTITESTER MULTITESTER DIGITALE

Ref.  
TEC145

Multímetro de rango manual con 32 rangos de medida de nueva generación y protección CAT.III 1000V, con amplio display iluminado y símbolos de función en pantalla.

- Multímetro digital de 3<sup>1/2</sup> dígitos (1999)
- Medidas de tensión CC/CA (200mV - 750V)
- Medidas de corriente CC/CA (2mA - 20A)
- Medidas de resistencia (200Ω-200mΩ), continuidad, Diodos y hFe
- Medida de capacidad, frecuencia y temperatura
- Retención de lectura Hold
- Protector de goma antigolpes.

Manual range multimeter with 32 new generation measurement ranges and CAT.III 1000V protection, with large illuminated display and function symbols on the screen.

- 3<sup>1/2</sup> digital multimeter (1999)
- DC/AC voltage measurements (200mV - 750V)
- DC/AC current measurements (2mA - 20A)
- Resistance measurements (200Ω-200mΩ), continuity, Diodes and hFe
- Measurement of capacity, frequency and temperature
- Hold Reading retention
- Anti-shock rubber protector.

Multímetro manual con 32 campos de medida de nueva generación y protección CAT.III 1000 V, con amplio display iluminado e símbolos de función sullo schermo.

- Multímetro digitale 3<sup>1/2</sup> (1999)
- Misure di tensione DC / AC (200mV - 750V)
- Misure di corrente CC / CA (2 mA - 20 A)
- Misure di resistenza (200Ω-200mΩ), continuità, diodi e hFe
- Misure di capacità, frequenza e temperatura
- Ritenzione di lettura Hold
- Protezione in gomma anti-shock.

**NEW**





## VACUÓMETRO SINCRONIZADOR VACUUMMATE ALLWEATHER VACUOMETRO

Ref.

TCMVRM5

Vacuómetro, sincronizador de admisión, analizador dinámico de fugas y tacómetro. Impermeable e insumergible con una funda especial. Posee mayor estabilidad que los indicadores analógicos o que cualquier otro sistema. Se autorregula a los cambios de presión barométrica. Alimentación con corriente continua de 12 V, se puede utilizar con cualquier batería de embarcación o vehículo o con un adaptador de entrada a la red (230V/12V). Indicadores LED de batería descargada y de alimentación no adecuada. Contiene: Cable y pinzas por alimentación 12V, tubos de santoprene de conexión, 2 juegos de adaptadores flexi-rígidos, caja de almacenaje.

Vacuumate allweather, 4 x carb/throttle valve. Shock resistant composite-moulded polyurethane and polycarbonate casing for maximum strength and resilience. Self-calibrates for barometric changes. Solid state sensors are drop proof. It has internal rechargeable 1,5Ah 7,2V NiMH batteries providing up to 6 hours autonomy. Battery power is conserved by auto-switch-off 5 minutes after last being used and LEDs use full power only when measurements are taken. Kit includes custom travel case, battery cord-set, T-connector & 2 full sets of unique flexi-rigid.

Vacuometro, sincronizzatore d'aspirazione, analizzatore dinamico di fughe e tachimetro. Impermeabile e con una custodia speciale. Possiede maggior sensibilità degli indicatori analogici o con altri sistemi. Si autoregola al cambio di pressione. Alimentazione con corrente continua da 12 V, si può utilizzare con qualsiasi batteria per imbarcazioni, veicoli e con un adattatore di entrata da 230V/12V. Indicatore LED di batteria scarica e di alimentazione non corretta. Contiene: cavi e pinzas per alimentazione 12V, tubi di connessione, 2 adattatori flexi-rígidi, scatola per conservare l'attrezzo.



## PINZA AMPERIMÉTRICA AMPERIC NIPPER PINZA AMPEROMETRICA

Ref.

TEC218

**Tenaza autorango y multifunción para AC y DC.**

Diámetro maxilar: 30 mm  
Display de 3 3/4 dígitos. Máx. 3999.  
Puede realizar medidas en:  
Corriente AC/DC: 40A/400A  
Precisión: +/- (1,9% + 5 d. en AC)  
Precisión: +/- (2,5% + 10 d. en DC)  
Ancho de banda: 50Hz - 500Hz (AC)  
Resolución: AC/DC 10mA. 100mV.  
Resistencia: 400 Ohms.

**Iron autoranging and multifunction for AC and DC.**

Jaw diameter: 30 mm  
Display of 3 3/4 digit. Max. 3999.  
Measurements in: AC/DC current: 40A/400A  
Precision: +/- (1,9% + 5 d. en AC)  
Precision: +/- (2,5% + 10 d. en DC)  
Bandwidth: 50 Hz - 500 Hz (AC)  
Resolution: AC/DC 10mA. 100mV.  
Resistance: 400 Ohms.

**Pinza multifunzione per AC e DC.**  
Diámetro max: 30 mm.  
Display da 3 3/4 dígitale. Máx. 3999.  
Può realizzare misurazioni in:  
Corrente AC/DC: 40A/400A.  
Precisione: +/- (1,9% + 5 d. en AC)  
Precisione: +/- (2,5% + 10 d. en DC)  
Banda larga: 50Hz - 500Hz (AC)  
Risoluzione: AC/DC 10mA. 100mV.  
Resistenza: 400 Ohms.



## TERMÓMETRO MULTIFUNCIONAL INFRARED THERMOMETER TERMOMETRO MULTIFUNZIONALE

Ref.

TEC423

Termómetro multifunción digital, por rayos infrarrojos.  
Emisividad fija: 0,95 Rango: -20°C + 320°C.  
Lectura en grados Centígrados y Fahrenheit.  
Precisión +/- 2%. Resolución: 1°C  
Distancia óptima de medida: de 6 a 60 cm.  
Retención de la última lectura. Autoapagado.

Multifunction digital infrared thermometer. Fixed emissivity: 0.95 range: - 20 °C 320 °C.  
Reading in Celsius and Fahrenheit.  
Precision +/- 2%. Resolution: 1°C  
Distancia optimal measurement: 6 to 60 cm.  
Retention of the last reading. Auto Off function.

Termometro multifunzione digitale, a infrarossi.  
Misurazione: 0,95 Rango: -20°C + 320°C.  
Lettura in gradi Centigradi e Fahrenheit.  
Precisione +/- 2%. Risoluzione: 1°C  
Distanza ottimale di misurazione: da 6 a 60 cm.  
Memoria dell'ultima lettura. Autospegnimento.



## SOPORTES DESCARGA EMBARCAIONES BOAT HANDLING JACKS & STANDS SUPPORTI SCARICO IMBARCAZIONI

### RECH10

#### KIT DESCARGA BARCOS

Para cargar o descargar embarcaciones de los remolques o cuna. Los remolques pueden entrar y salir de entre los gatos hidráulicos libremente, facilitando su tarea. Levantan embarcaciones de hasta 18 toneladas. Su recorrido de elevación es de 51 cm. Equipado con válvula de bloqueo que permite mantener el barco indefinidamente en la posición deseada. Puede actuar sobre tierra, grava, asfalto o cemento, tanto en la tienda, como en el varadero o exposición.

#### BOAT HANDLING JACKS KIT

Work station for bottom repair & cleaning. Trailer rolls in out past jacks, allowing you to take boats on or off trailers easily. Jacks have an auto lock allowing boats to be left on indefinitely. Can be used on dirt, gravel, black top or cement. Can be used anywhere! Shop, yard, showroom. Lifts boats up to 40,000 lbs.

#### KIT SCARICO BARCHE

Per caricare o scaricare imbarcazioni da rimorchi o sostegni. I rimorchi possono entrare e uscire tra i cric idraulici liberamente, facilitando il compito. Solleva imbarcazioni fino a 18 tonnellate. Escursione max di 51 cm. Fornito di valvola di blocco che permette di mantenere la barca nella posizione desiderata per diverso tempo. Può essere usato su terra, ghiaia, asfalto o cemento, come in negozio o in esposizione.



Ref.	DESCRIPCIÓN	DESCRIPTION	DESCRIZIONE	CANTIDAD UNITS QUANTITÀ
RECH10	Soportes hidráulicos	Jacks	Supporti idraulici	4
	Soportes	Straight arms	Supporti	4
	Soportes inclinados 25 cm	10" drop arms	Supporti inclinati 25 cm	4
	Soportes asiento barco	4" x 18" contact pads	Supporti appoggi barche	4
RECH10-1/4	Soportes hidráulicos	Jacks	Supporti idraulici	1
	Soportes	Straight arms	Supporti	1
	Soportes inclinados 25 cm	10" drop arms	Supporti inclinati 25 cm	1
	Soportes asiento barco	4" x 18" contact pads	Supporti appoggi barche	1

Ref.	DESCRIPCIÓN	DESCRIPTION	DESCRIZIONE	CAPACIDAD CAPACITY CAPACITÀ	ALTURA HEIGHT ALTEZZA
REC12	Soporte inclinado (25,4 cm)	Drop arm (25,4 cm)	Supporti elevatori (25,4 cm)	1.125 kg	59,7 - 107,9 cm
REC15	Soporte recto	Straight arm	Supporti		83,8 - 132 cm
		1ª posición	1st Pin hole	1ª posizione	900 kg
		2ª posición	2nd Pin hole	2ª posizione	1.800 kg
		3ª posición	3rd Pin hole	3ª posizione	3.600 kg
		4ª posición	4th Pin hole	4ª posizione	4.500 kg
REC16	Soporte elevador (12,7 cm)	Riser extension (12,7 cm)	Supporti elevatori (12,7 cm)	4.500 kg	96,5 - 144,8 cm
REC17	Soporte elevador (25,4 cm)	Riser extension (25,4 cm)	Supporti elevatori (25,4 cm)	4.500 kg	109,2 - 157,5 cm
REC18	Soporte estándar (10 x 45,7 cm)	Standard Pad 10 x 45,7 cm)	Supporti standard (10 x 5,7 cm)		
REC19	Soporte plus (15,2 x 76,2 cm)	Pad Plus (15,2 x 76,2 cm)	Supporti Plus (15,2 x 76,2 cm)	6.900 kg +	

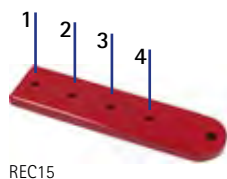

REC18  
REC19

### RECAMBIO PARA RECH10 SPARE FOR RECH10 RICAMBIO PER RECH10

Ref.	RECMAR®		
RECNSCYL	Pistón	Piston	Pistone

REF	YARDARM		
YARSLKTN	Kit reparación	Repair kit	Kit riparazione
YARJAT	Rueda	Wheel	Ruota
YARNSTVALVE	Llave de recambio	Spare T key	Chiave di ricambio
YARCPH	Manetas	Handle	Maniglia



YARCPH



YARSLKTN



YARJAT



RECNSCYL



YARNSTVALVE

**SOPORTES PARA EMBARCACIONES**  
**BOAT STANDS**  
**SUPPORTI PER IMBARCAZIONI**

Ref.

RECED36

Soporte para embarcaciones. Carga hasta 1.500 kilos.  
Economy dolly system. 3000 lbs. capacity  
Carrello per imbarcazioni. Carica fino a 1.500 chili.

RECmar®



**RUEDA DE RECAMBIO**  
**SPARE WHEEL**  
**RUOTA DI RICAMBIO**

Ref.

RECED36C

**SOPORTES PARA COLAS**  
**STANDS FOR STERN DRIVES**  
**SUPPORTI PER PIEDI**

Ref.

RECJO6HD

Carro con pistón hidráulico para la instalación de todo tipo de colas. Permite desmontar o montar colas, una sola persona. Especialmente útil en embarcaciones con plataforma integrada. Construido con brazos extra largos de sujeción y base con 4 ruedas neumáticas. Gran capacidad de elevación para colas de peso extra. También en colas de doble hélice. Varias regulaciones.

Stern drive installer. Works in all makes and models. Allows one man to remove and install stern drives. Especially helpful on boats with integrated swim platforms. Built with extra long clamping arms and wheel base, plus heavyduty lifting capacity for those extra heavy drives. Also works great on dual prop drives. Unique low cost shop tool. 4 air tires allow for rugged yard use.

Carro con pistone idraulico per l'installazione di tutti i tipi di piedi. Permette ad una persona di smontare o montare i piedi da solo. Specialmente utile nelle imbarcazioni con piattaforma integrata. Costruito con larghi bracci di fissaggio e una base con 4 ruote pneumatiche. Grande capacità di sollevamento per piedi con peso extra. Anche per piedi con doppia elica. Varie regolazioni.

RECmar®



**RECAMBIOS PARA RECJO6HD**  
**SPARE FOR RECJO6HD**  
**RICAMBIO PER RECJO6HD**

Ref.	DESCRIPCIÓN	DESCRIPTION	DESCRIZIONE
RECJOCYL	Pistón	Piston	Pistone
RECKRW	Rueda trasera	Rear wheel	Ruota posteriore
RECKFW	Rueda delantera	Front wheel	Ruota anteriore
RECJO-10	Suplemento 25 cm	Suplement 10"	Supplemento 25 cm
RECJHANDLEJO6HD	Maneta	Handle	Maniglia
RECJSRINGJO6HD	Muelle	Spring	Mola



RECOCYL



RECKRW



RECKFW



RECJO-10



RECJHANDLEJO6HD



RECJSRINGJO6HD

Ref.

YARSR5

YARDARM

Soporte para 5 colas. Mantiene el taller limpio y organizado. Protege las colas de golpes y daños.

Holds 5 stern drives. Keeps shop looking neat and clean. Protects drives from being cratched and damaged.

Supporto per 5 piedi. Mantiene l'officina pulita e organizzata. Protegge i piedi dai colpi e dai danni.

**RUEDA DE RECAMBIO**  
**SPARE WHEEL**  
**RUOTA DI RICAMBIO**

Ref.

YARSRC



**SOPORTES PARA MOTORES**  
**STANDS FOR ENGINES**  
**SUPPORTI PER MOTORI**



Ref.  
**RECTOOL1**

**NEW**

Soporte de trabajo giratorio 360° con ruedas. Para todo tipo de motores; GM, FORD, VOLVO. Ideal para reparaciones completas.

Allow engine to be rotated 320°. Adjustable mounting plate will accommodate all engine types.

Carrello supporto motore, permette il movimento per 360° utile per lavorazioni in coppa. Fornito di ruote piene, può montare tutti i blocchi GM, FORD, VOLVO.

Ref.	MOTORES ENGINES MOTORI
<b>YARES2</b>	GM, FORD, VOLVO
<b>YARFHA</b>	Kit FORD
<b>YARCHA</b>	Kit GM



**YARES2**

Soporte trabajo giratorio 360° con ruedas. Para todo tipo de motores; GM, FORD, VOLVO. Ideal para reparaciones completas. Se le pueden adaptar los soportes referencias YARCHA para GM y YARFHA para FORD y probar motores en funcionamiento.

Allows engine to be rotated 360° adjustable mounting plate will accommodate all engine types.

Supporto lavoro girevole 360° con ruote. Per tutti i tipi di motori; GM, FORD, VOLVO. Ideale per riparazioni complete. Si possono adattare i supporti di riferimento YARCHA per GM e YARFHA per FORD e provare i motori in funzione.

**YARFHA**

Kit soportes motores FORD, / Ford holder arms. / Kit supporto motore FORD

**YARCHA**

Kit soportes motores GM / GM engines arms / Kit supporto motore GM.



YARFHA

YARCHA

Soporte trabajo reparación todo tipo de colas.

Work station. Holds all kind of drives.

Supporto lavoro per riparare tutti i tipi di piedi.

Ref.  
**RECWS3**



**NEW**



## RACORS Y TORNILLERÍA RACORS & FITTINGS RACCORDI E VITERIA

### CONDUCTO TAPON DESAGÜE HOSE FITTING W/DRAIN PLUG KIT CONDOTTO CON TAPPO

Ref.	R.O. OEM
REC862210A01	MC862210A01



### TAPON DRENAJE DRAIN PLUG RUBINETTO

Ref.	R.O. OEM	ROSCA THREAD PASSO
REC82745	OMC379957 MC22-87238	1/4"
REC22-05154	MC22-16951Q1	3/4"



REC82745



REC22-05154

### TAPONES COLECTORES PIPE PLUGS TAPPI

Ref.	R.O. OEM	ROSCA THREAD PASSO
REC22-328022	22-32802	1/8 - 27
REC22-32803	M22-32803	3/8 - 18
BA50-090-075	22-33198A1	3/4 - 14



Ref.	R.O. OEM	ROSCA THREAD PASSO
REC22-36382	22-36382	1/4 - 18

### TUERCAS NUTS DADI

Ref.	R.O. OEM	ROSCA THREAD PASSO	
REC11-862903	11-82671013	3/8 - 24	Acero inox. / Stainless steel / Acciaio inox
REC11-34933	11-34933	7/16 - 24	Acero inox. / Stainless steel / Acciaio inox
REC11-8267089	11-35888	1/4 - 28	Acero inox. / Stainless steel / Acciaio inox
REC11-13436	11-82670911	5/16 - 24	Acero inox. / Stainless steel / Acciaio inox
REC11-52707Q1	11-52707Q1	3/4 - 16	Bronce / Bronze / Bronzo



### RACORS DE LATÓN RACORS IN BRASS RACCORDI IN OTTONE

Ref.	ROSCA THREAD PASSO	MANGUERA HOSE TUBO	
GS31067	1/4" NPT	3/8" = 9,5 mm	2
GS31066	1/4" NPT	5/16" = 7,9 mm	2
REC22-00842	1/4" NPT	1/4" = 9,5 mm	
REC22-00845	1/8" NPT	5/16" = 7,9 mm	



Ref.	ROSCA THREAD PASSO	MANGUERA HOSE TUBO	
GS31065	1/4" NPT	3/8" = 9,5 mm	2
GS31166	1/4" NPT	5/16" = 7,9 mm	2
GS31155	3/8" NPT	3/8" = 9,5 mm	2
GS31156	3/8" NPT	5/16" = 7,9 mm	2
GS31157	3/8" NPT	1/4" = 6,4 mm	2
GS31245	1/4"	1/4"	
REC22-00874	3/8"	3/8"	



### ENTRONQUE DE LATÓN MALE PIPE IN BRASS RACCORDI IN OTTONE

Ref.	ROSCA THREAD PASSO	MANGUERA HOSE TUBO
BRA125-3/16X1/4	3/16"	1/4"
BRA125-1/4X1/4	1/4"	1/4"
BRA125-1/4X3/8	1/4"	3/8"
BRA125-1/4X1/2	1/4"	1/2"
BRA125-5/16X3/8	5/16"	3/8"
BRA125-3/8X3/8	3/8"	3/8"
BRA125-3/8X1/2	3/8"	1/2"
BRA125-1/2X3/8	1/2"	3/8"
BRA125-1/2X1/2	1/2"	1/2"
BRA125-1/2X3/4	1/2"	3/4"
BRA125-5/8X3/8	5/8"	3/8"
BRA125-5/8X1/2	5/8"	1/2"
BRA125-5/8X3/4	5/8"	3/4"
BRA125-3/4X1/2	3/4"	1/2"
BRA125-3/4X3/4	3/4"	3/4"
BRA125-1X3/4	1"	3/4"



### SENSORES Y ALARMAS SENDERS & ALARMS SENSORI E ALLARMI

#### SENSOR PRESIÓN ACEITE OIL PRESSURE SENDER SENSORI PRESSIONE OLIO

Ref.	PRESIÓN PRESSURE PRESSIONE	ROSCA THREAD FILETTO	
REC8M0068784	180 PSI	1/8" NPTF USA	
FA90519	100 PSI	1/8" NPTF USA	
FA90515	5 bar	1/8" NPTF EURO	
FA90526	10 bar	1/8" NPTF EURO	



#### KIT TEMPERATURA Y PRESIÓN DE ACEITE CON ALARMA COMPLETE TEMPERATURE & OIL PRESSURE WARNING KIT KIT TEMPERATURA E PRESSIONI DELL'OLIO CON ALLARME

Ref.
REC41400



#### SENSOR TEMPERATURA TEMPERATURE SENDER SENSORI TEMPERATURA

Ref.	ROSCA THREAD FILETTO	
REC97258A1	1/2" = 14 NPTF	
FA90401	1/8"	USA
FA90412	1/8"	EURO



# MANGUERAS ESCAPE EXHAUST HOSES TUBI DI SCARICO

## SCAMO / SP

Ref.	Ø (mm)	RADIO CURVA. RADIUS BEND RADIO CURV. (mm)	
GS35033	30	30	
GS35034	40	40	
GS35045	45	45	
GS35035	51	51	
GS35036	60	60	
GS35037	63,5	63,5	
GS35038	76	76	
GS35039	80	80	
GS35040	90	90	-30°C → +100°C
GS35041	102	152	
GS35042	120	240	
GS35043	127	255	
GS35044	152	305	
GS35046	203	815	
GS35047	254	1270	
GS35048	305	1830	



Por metros. Manguera de goma de espiral ondulada para sistemas de escape y refrigeración. Su particular estructura permite efectuar radio de curvatura de 1 a 1,5 vueltas por el diámetro interno.

Cumple normas: SAE J 2006 - 2003 R2, ISO 13363 - 2004 T-2 Class B.

Homologación: Rina n.º 0474, Lloyd's n.º 96/00/127

Per meters. General purpose hose. Hardwall corrugated cover rubber hose. Extremely flexible. The construction ensures bending radius up to 1 / 1.5 for the inside diameter.

Meets or exceeds: SAE J 2006 - 2003 R2, ISO 13363 - 2004 T-2 Class B.

Homologation: Rina n.º 0474, Lloyd's n.º 96/00/127

Per metro. Tubo in gomma spiralato per sistemi di scarico e refrigerazione. La sua particolare struttura permette di effettuare un raggio di curvatura molto stretto, senza strozzarsi.

Soddisfa le normative: SAE J 2006 - 2003 R2, ISO 13363 - 2004 T-2 Class B.

Omologazione: Rina n.º 0474, Lloyd's n.º 96/00/127

## TUBO DE FIBRA TUBING CONNECTOR TUBO IN FIBRA

Ref.	Ø EXT		
TRI260-4001	4" = 102 mm	152 mm	
TRI260-4121	4 <sup>1/2</sup> " = 115 mm	152 mm	
TRI260-5001	5" = 127 mm	152 mm	+121°C
TRI260-6001	6" = 152 mm	152 mm	



Tubo de fibra para empalme de mangueras en sistemas de escape húmedos.

Bajo demanda, puede suministrarse hasta 18" = 457 mm

Manufactured in fiberglass.

Available on demand up to 18" = 457 mm.

Tubo in fibra per congiunzioni di sistemi di tubazioni.

Su richiesta si può vendere fino a 18" = 457 mm.



## SILICONA SILICONE SILICONE

Ref.	Ø INT		
TRI202V-4004	4" = 102 mm	50 cm	
TRI202V-5004	5" = 127 mm	50 cm	
TRI202V-5124	5 <sup>1/2</sup> " = 140 mm	50 cm	+177°C
TRI202V-6004	6" = 152 mm	50 cm	
TRI202V-8004	8" = 203 mm	50 cm	



Ref.	Ø INT		
TRI252V0340-36	3/4" = 19 mm	30 cm	
TRI252V1000-36	1" = 25 mm	30 cm	
TRI252V1140-36	1 <sup>1/4</sup> " = 32 mm	30 cm	+177°C
TRI252V1120-36	1 <sup>1/2</sup> " = 38 mm	30 cm	
TRI252V1340-36	1 <sup>3/4</sup> " = 45 mm	30 cm	



Bajo demanda, puede suministrarse hasta 18" = 457 mm  
Available on demand up to 18" = 457 mm.

Su richiesta si può vendere fino a 18" = 457 mm.



## CODO 90° DE SILICONA SILICONE 90° ELBOW GOMITO A 90° IN SILICONE

Ref.	Ø INT		
TRI290V-4000	4" = 102 mm		
TRI290V-4500	4 <sup>1/2</sup> " = 115 mm		+177°C
TRI290V-5000	5" = 127 mm		
TRI290V-6000	6" = 152 mm		



## FUELLE DE SILICONA SILICONE BELLOW MANICOTTO IN SILICONE

Ref.	Ø INT		
TRI270V-4000	4" = 102 mm	5 <sup>1/4</sup> " = 133 mm	
TRI270V-4500	4 <sup>1/2</sup> " = 115 mm	5 <sup>1/4</sup> " = 133 mm	
TRI270V-5000	5" = 127 mm	6" = 152 mm	+177°C
TRI270V-6000	6" = 152 mm	7" = 177 mm	



# LLAVES DE ARRANQUE IGNITION STARTER SWITCHES CHIAVE DI AVVIAMENTO

Ref.	PANEL PANEL PANNELLO	TERMINALES TERMINALS TERMINALI	POSICIONES POSITIONS POSIZIONE
MP39200	28 mm	3	3
MP41030	15 mm	3	3
GS11150	28 mm	3	3
GS11151	30 mm	3	3
GS11152	29 mm	3	3
GS11153	30 mm	5	3
GS11154	27 mm	4	3
GS11155	15 mm	7	4
GS11156	6 mm	7	4
GS11157	6 mm	6	3
GS11158	15 mm	6	3
GS11159	16 mm	6	3

## MP39200

Llave de arranque de 3 posiciones con retroceso, Off-Contacto-Arranque. Fabricada en poliéster anticorrosión. Montadas por Chaparral, Baja, Celebrity, Four Winns, Larson, Rinker, Wellcraft, ChrisCraft.

3 positions, Off-Run-Start. 3 screws. Conventional  
Chiave di avviamento a 3 posizioni con ritorno: Off-Contatto-Avviamento. In poliestere anticorrosione. Montato da Chaparral, Baja, Celebrity, Four Winns, Larson, Rinker, Wellcraft, ChrisCraft.



## MP41030

Llave de arranque de 3 posiciones con retroceso, Off-Contacto-Arranque. Fabricada en poliéster anticorrosión. Montadas por Bayliner y SeaRay desde el año 1990.

3 positions, Off-Run-Start. 3 screws. Conventional.  
Chiave di avviamento a 3 posizioni con ritorno: Off-Contatto-Avviamento. In poliestere anticorrosione. Montato da Bayliner e SeaRay dall'anno 1990.



## GS11150

Llave de arranque de 3 posiciones con retroceso, Off-Contacto-Arranque. Fabricada en latón con frontal cromado. 15A 12V

Chrome plated brass face nut and brass back-up nut. 3 positions with return, Off-Ignition-Start. 15A 12V  
Chiave di avviamento a 3 posizioni con ritorno Off-Contatto-Avviamento. In ottone con frontale cromato. 15A 12V



## GS11151

Fabricada en latón con frontal protector de goma. 3 posiciones con retroceso, Off-Contacto-Arranque.

Made in brass with rubber cap protector. 3 positions with return, Off-Ignition-Start.

Prodotta in ottone con parte frontale in gomma, 3 posizioni con ritorno, Off-Contatto-Avviamento.



## GS11152

Fabricada en plástico con frontal protector de goma. 3 posiciones con retroceso, Off-Contacto-Arranque.

Made in plastic with rubber cap protector. 3 positions with return, Off-Ignition-Start.

Prodotta in plastica con parte frontale in gomma 3 posizioni con ritorno, Off-Contatto-Avviamento.



## GS11153

Fabricada en plástico con frontal protector de goma. 3 posiciones con retroceso, Off-Contacto-Arranque.

Made in plastic with rubber cap protector. 3 positions with return, Off-Ignition-Start.

Prodotta in plastica con parte frontale in gomma 3 posizioni con ritorno, Off-Contatto-Avviamento.



## GS11154

Fabricada en latón con frontal protector de goma. 3 posiciones con retroceso, Off-Contacto-Arranque.

Made in brass with rubber cap protector. 3 positions with return, Off-Ignition-Start.

Prodotta in ottone con parte frontale in gomma. 3 posizioni con ritorno, Off-Contatto-Avviamento.



## GS11155

Fabricada en plástico. 4 posiciones con retroceso, Accesorios-Off-Contacto-Arranque.

Made in plastic with rubber cap protector. 4 positions with return, Acc-Off-Ignition-Start.

Prodotta in plastica. 4 posizioni con ritorno, Blower-Off-Contatto-Avviamento.



## GS11156

Fabricada en plástico. 4 posiciones con retroceso, Accesorios-Off-Contacto-Arranque.

Made in plastic with rubber cap protector. 4 positions with return, Acc-Off-Ignition-Start.

Prodotto in plastica. 4 posizioni con ritorno, Blower-Off-Contatto-Avviamento.



## GS11157

Fabricada en plástico. 6 terminales. 3 posiciones con retroceso, Off-Contacto-Arranque (Starter).

Made in plastic. 3 positions with return, Off-Ignition-Start (Choke). 6 terminals.

Prodotta in plastica. 6 terminali 3 posizioni con ritorno, Off-Contatto-Avviamento(Starter).



## GS11159

Fabricada en plástico. 6 terminales con cables incluidos. 3 posiciones con retroceso, Off-Contacto-Arranque (Starter).

Made in plastic. 3 positions with return, Off-Ignition-Start (Choke). 6 terminals with wires included.

Prodotta in plastica. 6 terminali con cavi inclusi. 3 posizioni con ritorno, Off-Contatto-Avviamento (Starter).



# IDENTIFICACION MOTOR ENGINE'S IDENTIFICATION IDENTIFICAZIONE MOTORE

**ROTACIÓN ESTÁNDAR  
STANDARD ROTATION  
ROTAZIONE STANDAR**

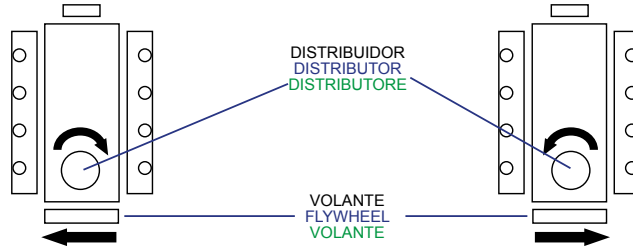

**CONTRAROTACIÓN  
CCW ROTATION  
CONTRO ROTAZIONE**

MODELO MODEL MODELLO	BASE	CYL.	C.C.	Ø PISTÓN Ø PISTON Ø PISTONE	COJINETE BIELA BEARING CONNECTING ROD BRONZINE BIELLA	COJINETE BANCADA BEARING CRANKSHAFT BRONZINE BANCO	APRIETE DE MOTOR EN kg/m / TORQUE ENGINE kg/m / DATI DI SERRAGGIO Kg/m			
							CULATA HEAD TESTATA	VOLANTE FLYWHEEL VOLANO	BIELA CONNECTING ROD BIELLA	CIGÜENAL CRANKSHAFT ALBERO MOTORE
<b>CHRIS-CRAFT</b>										
185	GM 283	V8	4.6 L	98.42	50.80	58.38	8.8	8.2	4.5	9.5
200 - 215	GM 307	V8	4.9 L	98.42	53.34	62.19	8.8	8.2	6.2	9.5
200 - 225	GM 305	V8	5.0 L	95.00	53.34	62.19	8.8	8.2	6.2	9.5
210 - 230	GM 327	V8	5.4 L	101.60	53.34	62.19	8.8	8.2	6.2	9.5
250 - 300	GM 350	V8	5.7 L	101.60	53.34	62.19	8.8	8.2	6.2	9.5
330	GM 454	V8	7.4 L	108.00	55.88	69.81	10.8	6.2	6.8	10.8
<b>CRUSADER- RIVA</b>										
185	GM 283	V8	4.6 L	98.42	50.80	58.38	8.8	8.2	4.5	9.5
190 - 220 - 210	GM 305	V8	5.0 L	95.00	53.34	62.19	8.8	8.2	6.2	9.5
200	GM 307	V8	5.0 L	98.42	53.34	62.19	8.8	8.2	6.2	9.5
210-225-230-250	GM 327	V8	5.3 L	101.60	53.34	62.19	8.8	8.2	6.2	9.5
265 - 270 - 350	GM 350	V8	5.7 L	101.60	53.34	62.19	8.8	8.2	6.2	9.5
320	GM 427	V8	7.0 L	108.00	55.88	69.81	10.8	6.2	6.8	10.8
320-350-355-365	GM 454	V8	7.4 L	108.00	55.88	69.81	10.8	6.2	6.8	10.8
380	GM 502	V8	8.2 L	113.43	55.88	69.81	10.8	6.2	6.8	14.9
<b>MERCURISER</b>										
120	GM 153	L4	2.5 L	98.42	50.80	58.38	12.5-13.8	8.2 - 8.8	4 - 4.5	8.2 - 9.5
140	GM 181	L4	3.0 L	101.60	53.34	58.38	12.5-13.8	8.2 - 8.8	4 - 4.5	8.2 - 9.5
170-180-190-470	GM 224	L4	3.7 L	110.74	63.44	69.77				
165	GM 250	L6	4.0 L	98.42	50.80-53.34	58.38	12.5-13.8	8.2 - 8.8	4 - 4.5	8.2 - 9.5
175 - 205	GM 262	V6	4.3 L	101.60	57.14	62.19	8.8	8.2	6.2	9.5
898-200-228-230	GM 305	V8	5.0 L	95.00	53.34	62.19	8.8	8.2	6.2	9.5
250-260-270-280	GM 350	V8	5.7 L	101.60	53.34	62.19	8.8	8.2	6.2	9.5
300 - 320 - 350	GM 350	V8	5.7 L	101.60	53.34	62.19	8.8	8.2	6.2	9.5
6.2	GM 377	V8	6.2 L	101.60	53.34	62.19		10	1° ⇨ 2.7 Kg 2° ⇨ 45°	1° ⇨ 2K 2° ⇨ 73° 3° ⇨ 2K 4° ⇨ 43° 5° ⇨ 73°
325	GM 427	V8	7.0 L	108.00	55.88	69.81	10.8	6.2	6.8	10.8
330-370-400-425	GM 454	V8	7.4 L	108.00	55.88	69.81	10.8	6.2	6.8	10.8
8.1	GM 496	V8	8.1 L	108.00		69.81	1° ⇨ 3 kg 2° ⇨ 3 kg + 120° 3° ⇨ 60° tornillos largos y medios 60° Long and medium screws 60° Viti lunghe e corte 4° ⇨ 30° tornillos cortos 30° short screws 30° viti corte	10	1° ⇨ 3 Kg 2° ⇨ 90°	1° ⇨ 3k 2° ⇨ 90° Tornillos 90° Screw 90° Viti 1° ⇨ 3k 2° ⇨ 80° Stud
500 - 502	GM 502	V8	8.2 L	113.43	55.88	69.81	10.8	6.2	6.8	14.9
215 - 225 - 888	FD 302	V8	5.0 L	101.60	53.94	57.12	8.8-9.8	10.2 - 11.5	2.5 - 3.3	8.2 - 9.5
233 - 255	FD 351	V8	5.8 L	101.60	58.70	76.21	14.2-15.2	10.2 - 11.5	5.5 - 6	13 - 14
<b>OMC</b>										
120	GM 153	L4	2.5 L	98.42	50.80	58.38	12.5-13.8	8.2 - 8.8	4 - 4.5	8.2 - 9.5
140	GM 181	L4	3.0 L	101.60	53.34	58.38	12.5-13.8	8.2 - 8.8	4 - 4.5	8.2 - 9.5
165	GM 250	L6	4.0 L	98.42	50.80-53.34	58.38	12.5-13.8	8.2 - 8.8	4 - 4.5	8.2 - 9.5
155	GM 225	V6	3.6 L	95.25	50.80	63.50	9 - 11	6.2 - 6.9	4.2 - 5.5	13.2-16.5
170	GM 229	V6	3.8 L	95.00	53.34	62.19	8.8	8.2	6.2	9.5
175	GM 231	V6	3.8 L	96.52	57.14	63.50	8.8	8.2	6.2	9.5
205	GM 262	V6	4.3 L	101.60	57.14	62.19	8.8	8.2	6.2	9.5
185-200-210-220	GM 305	V8	5.0 L	95.00	53.34	62.19	8.8	8.2	6.2	9.5
250-260-270-290	GM 350	V8	5.7 L	101.60	53.34	62.19	8.8	8.2	6.2	9.5
310 - 330 - 335	GM 454	V8	7.4 L	108.00	55.88	69.81	10.8	6.2	6.8	10.8
160 - 175 - 190	FD 302	V8	5.0 L	101.60	53.94	57.12	8.8 - 9.8	10.2 - 11.5	2.5 - 3.3	8.2 - 9.5
235 - 240 - 250	FD 351	V8	5.8 L	101.60	58.70	76.21	14.2-15.2	10.2 - 11.5	5.5 - 6	13 - 14
295 - 340	FD 460	V8	7.5 L	110.70	63.24	75.95				



MODELO MODEL MODELLO	BASE	CYL.	C.C.	Ø PISTÓN Ø PISTON Ø PISTONE	COJINETE BIELA BEARING CONNECTING ROD BRONZINE BIELLA	COJINETE BANCADA BEARING CRANKSHAFT BRONZINE BANCO	APRIETE DE MOTOR EN kg/m / TORQUE ENGINE kg/m / DATI DI SERRAGGIO Kg/m			
							CULATA HEAD TESTATA	VOLANTE FLYWHEEL VOLANO	BIELA CONNECTING ROD BIELLA	CIGÜENAL CRANKSHAFT ALBERO MOTORE
<b>VOLVO PENTA</b>										
3.0GL - 3.0GS	GM 181	L4	3.0 L	101.60	53.34	58.38	12.5-13.8	8.2 - 8.8	4 - 4.5	8.2
155	GM 225	V6	3.6 L	95.25	50.80	63.50	9 - 11	6.2 - 6.9	4.2 - 4.5	13.2 - 16.5
175	GM 229	V6	3.8 L	95.00	53.34	62.19	8.8	8.2	6.2	9.5
205-431-432-434	GM 262	V6	4.3 L	101.60	57.14	62.19	8.8	8.2	6.2	9.5
200-211-225-231	GM 305	V8	5.0 L	95.00	53.34	62.19	8.8	8.2	6.2	9.5
500 - 501	GM 305	V8	5.0 L	95.00	53.34	62.19	8.8	8.2	6.2	9.5
255-260-261-271	GM 350	V8	5.7 L	101.60	53.34	62.19	8.8	8.2	6.2	9.5
280-290-311-570	GM 350	V8	5.7 L	101.60	53.34	62.19	8.8	8.2	6.2	9.5
740-7.4GL-7.4Gi	GM 454	V8	7.4 L	108.00	55.88	69.81	10.8	6.2	6.8	10.8
8.1	GM 496	V8	8.1 L	108.00		69.81	1° ⇒ 3 kg 2° ⇒ 3 kg + 120° 3° ⇒ 60° tornillos largos y medios 60° Long and medium screws 60° Viti lunghe e corte 4° ⇒ 30° tornillos cortos 30° short screws 30° viti corte	10	1° ⇒ 3 Kg 2° ⇒ 90°	1° ⇒ 3k 2° ⇒ 90° Tornillos 90° Screw 90° Viti 1° ⇒ 3k 2° ⇒ 80° Stud
8.2GL-8.2GSi	GM 502	V8	8.2 L	113.43	55.88	69.81	10.8	6.2	6.8	14.9
190-5.0FL-5.0Fi	FD 302	V8	5.0 L	101.60	53.94	57.12	8.8-9.8	10.2 - 11.5	2.5 - 3.3	8.2 - 9.5
240-5.8FL-5.8Fi	FD 351	V8	5.8 L	101.60	58.70	76.21	14.2-15.2	10.2 - 11.5	5.5 - 6	13 - 14
B 18		L4	1.8 L	84.14	54.08	63.44	9	5	5.5	12.5
B 20		L4	2.0 L	88.90	54.08	63.44	9	5	5.5	12.5
B 21		L4	2.1 L	92.00	54.08	63.44	9	7.2	6.2	10.8
B 23		L4	2.3 L	96.00	54.08	63.44	10.8	7.2	6.2	10.8
B 25		L4	2.5 L	96.00	48.98	54.98	2+4+120°	7	2 + 90°	11
B 30		L6	3.0 L	88.90	54.08	63.44	9	5	5.5	12.5
MD 1 A		L 1	0.445L	79.37						
MD 1 B		L 1	0.560 L	88.90	53.96	66.64	11	70	6.5	4.5
MD 2 A		L 2	0.890 L	79.37						
MD 2 B		L 2	1.12 L	88.90	53.96	66.64	11	70	6.5	4.5
MD 3 B		L 3	1.168 L	88.90	53.96	66.64	11	70	6.5	4.5
MD 5		L 1	0.443 L	84.00	51.00	54.00	7	50	7	7
MD 6		L 2	0.631 L	70.00	50.00	50.00	7	18	5	5
MD 7 A		L 2	0.744 L	76.00	50.00	50.00	7	18	5	5
MD 7 B		L 2	0.744 L	76.00	50.00	50.00	7	18	5	5
MD 11		L 2	1.12 L	88.90	53.96	66.64	11	50	6.5	4.5
MD 17		L 3	1.68 L	88.90	53.96	66.64	11	59	6.5	4.5
MD 21		L 4	2.112 L	90.00	49.99	55/55.19	7	6.5	6	10
D 30		L 4	2.39 L	92.00	56.48	69.98	13	11.5	11.3	14
D 31		L 4	2.39 L	92.00	56.48	69.98	13	11.5	11.3	14
D 32		L 6	3.17 L	90.00	49.99	55/55.19	7	6.5	6	10
D 40		L 6	3.59 L	92.00	56.48	69.98	13	11.5	11.3	14
D 41		L 6	3.59 L	92.00	56.48	69.98	13	11.5	11.3	14
D 42		L 6	3.59 L	92.00	56.48	69.98	13	11.5	11.3	14
2001		L 1	0.43 L	79.00	48.00	60.00	2 - 7	6.5	7	2 - 6
2002		L 2	0.852 L	79.00	48.00	60.00	2 - 7	6.5	7	2 - 6
2003		L 3	1.278 L	79.00	48.00	60.00	2 - 7	6.5	7	2 - 6
2003 T		L 3	1.278 L	79.00	48.00	60.00	2 - 7	6.5	7	2 - 6
D1-13A		2	0,51L	67		23	36,5	74	23	27
D1-20A		3	0,76L	67		23	36,5	74	23	27
D1-30A		3	1,13L	77		23	51	74	32	27
D2-40A		4	1,51L	77		23	51	74	32	27
MD2010		2	0,45L	67	21-26	25-30	35-40	70-80		
MD2020		3	0,68L	67	21-26	25-30	35-40	70-80		
MD2030		3	0,95L	75	30-35	25-30	50-53	60-70		
MD2040		3	1,50L	84	50-55	50-55	90-95	60-70		
D2-55/75		4	2,2L	84	49-54	49-54	98-103	69-78		
D3		5	2,4L	81			50 + 90° + 90°	45 + 65°		
D4		4	3,67	103			150 + 180° + 90°	100 + 45°	65 + 90°	
D5		4	4,76	108		50+60°+60°	130 + 90°	30+60°+60°		30+ 60° + 60°
D6		6	5,5	103			150 + 180° + 90°	100 + 45°	65 + 90°	
D7		6	7,15	108		50+60°+60°	130 + 90°	30+60°+60°		30+ 60° + 60°

# EQUIPAMIENTO STANDARD BASE MOTORES GM NUEVOS GM STANDARD EQUIPMENT BASE NEW ENGINE VERSIONE STANDARD BASE MOTORE GM NUOVO

## MODELO MOTOR ENGINE MODEL MODELLO MOTORE

181 STANDARD (3.0L)

Ref.	R.O. OEM
RECGM181	Mercuriser: 864626A01, 864626A02 Volvo: 3857760



Base motor nueva	Base engine	Base motore nuova	GM 3.0L & 3.0LX
Cubicaje	Displacement	Cilindrata	3.0L (181 CID)
Potencia cigüeñal	Horse Power	Potenza all'albero motore	140 HP @ 4800 rpm
Torsión	Torque	Torcente	117 lb-ft @ 3600 rpm
Retén cigüeñal	Rear Main seal	Paraolio posterior albero motore	1
Rotación	Rotation	Rotazione	Standard
Cilindros	Cylinders	Cilindri	Inline 4
Agujero	Bore	Buco	Standard
Orden encendido	Firing order	Ordine di accensione	1-3-4-2
Capacidad	Oil pan capacity	Coppa l'olio capacità	4 quarts
Tipo aceite	Oil type	Tipo olio	SAE 15W40 Pennzoil Marine

Reemplaza Mercuriser, Volvo Penta, OMC, Crusader e Indmar (1991+), con base GM.

### EQUIPO STANDARD

Todos los componentes internos  
Volante 14"  
Harmonic Balancer  
Distribuidor  
Bujías  
Culata  
Tapa válvulas  
Tapa distribución  
Cárter de aceite  
Bomba de agua

### IMPORTANTE

Para substituir a los motores anteriores a 1989, con retén de cigüeñal de 2 piezas y con volante de menos diámetro, debemos substituir el motor de arranque y el acoplamiento del motor

Replace Mercuriser, Volvo Penta, OMC, Crusader and Indmar (1991+), with base GM.

### STANDARD EQUIPMENT

All internal components  
14" Flywheel  
Harmonic Balancer  
Distributor  
Sparks  
Cylinder Head  
Valve Cover  
Timing Cover  
Oil Pan  
Water Pump

### IMPORTANT

To replace the engines before 1989 with 2 pieces crankshaft seal and flywheel of less diameter, you must substitute the starter and the drive plate of the engine

Sostituisce Mercuriser, Volvo Penta, OMC, Crusader e Indmar (1991+), con base GM.

### CARATTERISTICHE STANDARD

Tutti i componenti interni  
Volano 14"  
Harmonic Balancer  
Distributore  
Candele  
Testata  
Coperchio punterie  
Carter distribuzione  
Coppa dell'olio  
Pompa dell'acqua

### IMPORTANTE

Per sostituire i motori prima del 1989, con paraolio albero motore in 2 pz, e volante di dimensioni più piccole, bisogna sostituire il motorino d'avviamento e l'accoppiamento del motore.

## MODELO MOTOR ENGINE MODEL MODELLO MOTORE

4.3L - 4.3GXi & 4.3L MPI  
VORTEC

Ref.	R.O. OEM R.O.
RECGM262VORTEC	Mercuriser: 879150A31 Volvo: 3801555



Base motor nueva	Base engine	Base motore nuova	4.3L & 4.3GXi
Cubicaje	Displacement	Cilindrata	4.3L (262 CID)
Potencia cigüeñal	Horse Power	Potenza all'albero motore	223 HP @ 4800 rpm
Torsión	Torque	Torcente	267 lb-ft @ 2800 rpm
Retén cigüeñal	Rear Main seal	Paraolio posterior albero motore	1
Colector admisión	Intake manifold	Collettore aspirazione	8
Tornillos	Bolts	Viti	8
Rotación	Rotation	Rotazione	Standard
Cilindros	Cylinders	Cilindri	90° V6
Cigüeñal	Crankshaft	Albero Motore	Remanufactured
Agujero	Bore	Buco	Standard
Orden encendido	Firing order	Ordine di accensione	1-6-5-4-3-2
Capacidad	Oil pan capacity	Coppa l'olio capacità	4.5 quarts
Tipo aceite	Oil type	Tipo olio	SAE 15W40 Pennzoil Marine
Nº Bloque	Block casting number	Num. blocco	12600234/324
Nº Culata	Head casting number	Num. Testa	12557113/12558114

Reemplaza Mercuriser, Volvo, OMC, Crusader e Indmar (2008+), Vortec 4.3 con tapa de distribución en aluminio.

Eje calibrado

### EQUIPO STANDARD

Todos los componentes internos  
Tapa válvulas  
Tapa distribución aluminio  
Cárter de aceite

### IMPORTANTE

El colector de admisión de este motor está fijado a las culatas con 8 tornillos. Si el motor a substituir tiene 12 tornillos se debe ordenar:

MP425036 Colector admisión carburador 4 cuerpos.

o

MP425024 Colector admisión carburador 2 cuerpos + MP001204 Tornillos colector

NO SUSTITUYE A BLOQUES 090, 090M

Replace Mercuriser, Volvo, OMC, Crusader and Indmar (2008+), Vortec 4.3 with aluminium timing cover.

Balance shaft

### STANDARD EQUIPMENT

All internal components  
Valve covers  
Timing cover aluminium  
Oil Pan

### IMPORTANT

The intake manifold in this engine is fixed to the heads with 8 screws. If the engine to substitute have 12 screws, you must order:

MP425036 Intake manifold carburetor 4 bbl.

or

MP425024 Intake manifold carburetor 2 bbl. + MP001204 Bolts for intake manifold

DOES NOT REPLACE BLOCKS 090, 090M

Sostituisce Mercuriser, Volvo, OMC, Crusader e Indmar (2008+), Vortec 4.3 con carter distribuzione in alluminio.

Asse bilanciato

### CARATTERISTICHE STANDARD

Tutti i componenti interni  
Coperchio punterie  
Carter distribuzione in alluminio  
Coppa dell'olio

### IMPORTANTE

Il collettore d'aspirazione di questo motore va montato con 8 viti. Nel caso il vecchio motore avesse montato il modello con 12 viti, bisognerà ordinare:

MP425036 Collet. aspirazione carburatore a 4 corpi.

o

MP425024 Collet. aspirazione carburatore a 2 corpi + MP001204 Viteria collettore

NON SOSTITUISCE BLOCCHI 090, 090M

**MODELO MOTOR  
ENGINE MODEL  
MODELLO MOTORE**

**(GM350) 5.7L**

Ref.	R.O. OEM R.O.
RECGM350PREVORTEC	Mercuriser: 807447R2, 807447R50 Volvo: 856706, 856901



Base motor nueva	Base engine	Base motore nuova	GM 5.7L
Cubicaje	Displacement	Cilindrata	5.7L (350 CID)
Potencia cigüeñal	Horse Power	Potenza all'albero motore	270 HP @ 4800 rpm
Torsión	Torque	Torcente	340 lb-ft @ 3200 rpm
Retén cigüeñal	Rear Main seal	Paraolio posteriore albero motore	1
Colector admisión	Intake manifold	Collettore aspirazione	12
Tornillos	Bolts	Viti	12
Rotación	Rotation	Rotazione	Standard
Cilindros	Cylinders	Cilindri	90° V8
Agujero	Bore	Buco	Standard
Orden encendido	Firing order	Ordine di accensione	1-8-4-3-6-5-7-2
Capacidad	Oil pan capacity	Coppa l'olio capacità	5.5 quarts
Tipo aceite	Oil type	Tipo olio	SAE 15W40 Pennzoil Marine
Ratio composición	Composition Ratio	Rapporto di composizione	9:4:1
Tapa árbol de levas plano	Flat Tappet Camshaft	Tappo albero motore plano	

Reemplaza Mercuriser, Volvo, OMC y Crusader. Carburación o TBI (1987-1995).  
Acepta bomba mecánica de combustible

Replace Mercuriser, Volvo, OMC and Crusader. Carbureted or TBI Long Block (1987-1995).  
Accepts mechanical fuel pump

Sostituisce Mercuriser, Volvo, OMC e Crusader. a carburatori o TBI (1987-1995).  
Predisposto per pompa benzina meccanica

**EQUIPO STANDARD**

Todos los componentes internos  
Tapas válvulas  
Tapa distribución metálica  
Cárter de aceite

**STANDARD EQUIPMENT**

All internal components  
Valve covers  
Metallic Timing cover  
Oil Pan

**CARATTERISTICHE STANDARD**

Tutti i componenti interni  
Coperchio punterie  
Carter distribuzione  
Coppa dell'olio

**MODELO MOTOR  
ENGINE MODEL  
MODELLO MOTORE**

**(GM350) 5.7L  
VORTEC**

Ref.	R.O. OEM R.O.
RECGM350VORTEC	Mercuriser: 863661A1, 8M0088397 Volvo: 3801411, 3801529



Base motor nueva	Base engine	Base motore nuova	GM 5.7L
Cubicaje	Displacement	Cilindrata	5.7L (350 CID)
Potencia cigüeñal	Horse Power	Potenza all'albero motore	330 HP @ 4800 rpm
Torsión	Torque	Torcente	355 lb-ft @ 3600 rpm (4bbl carbureted)
Retén cigüeñal	Rear Main seal	Paraolio posteriore albero motore	1
Colector admisión	Intake manifold	Collettore aspirazione	8
Tornillos	Bolts	Viti	8
Rotación	Rotation	Rotazione	Standard
Cilindros	Cylinders	Cilindri	90° V8
Agujero	Bore	Buco	Standard
Orden encendido	Firing order	Ordine di accensione	1-8-4-3-6-5-7-2
Capacidad	Oil pan capacity	Coppa l'olio capacità	5.5 quarts
Tipo aceite	Oil type	Tipo olio	SAE 15W40 Pennzoil Marine
Ratio composición	Composition Ratio	Rapporto di composizione	9:4:1
Árbol de levas de rodillos hidráulicos	Hydraulic Roller Camshaft	Albero a camme del rullo idraulico	

Reemplaza Mercuriser, Volvo, OMC y Crusader. Carburación o TBI (1996+).  
Bomba de combustible eléctrica.

Replace Mercuriser, Volvo, OMC and Crusader. Carbureted or TBI Long Block (1996+).  
Electric fuel pump.

Sostituisce Mercuriser, Volvo, OMC e Crusader. a carburatori o TBI (1996+).  
Pompa benzina elettrica.

**EQUIPO STANDARD**

Todos los componentes internos  
Tapas válvulas  
Tapa distribución de composite  
Cárter de aceite

**STANDARD EQUIPMENT**

All internal components  
Valve covers  
Composite Timing cover  
Oil Pan

**CARATTERISTICHE STANDARD**

Tutti i componenti interni  
Coperchio punterie  
Carter distribuzione  
Coppa dell'olio

**PARA MOTORES MPI  
PEDIR LA REF. REC15254  
TAPA DISTRIBUCION CON  
SENSOR**

**FOR ENGINE MPI  
ORDER REF. REC15254  
TIMING COVER WITH  
SENSOR**

**PER MOTORI MPI  
AGGIUNGERE LA REF.  
REC15254  
COPERCHIO DISTRIBUZIONE  
CON sensore**

## MODELO MOTOR ENGINE MODEL MODELLO MOTORE

(GM350) 5.7L

Ref.	R.O. OEM R.O.
RECGM350MPI	Mercuriser: 800-866138A03 Volvo: 3862058



Base motor nueva	Base engine	Base motore nuova	GM 5.7L
Cubicaje	Displacement	Cilindrata	5.7L (350 CID)
Potencia cigüeñal	Horse Power	Potenza all'albero motore	350 HP @ 4500 rpm (4bbl carbureted)
Torsión	Torque	Torcente	425 lb-ft @ 3600 rpm
Retén cigüeñal	Rear Main seal	Paraolio posteriore albero motore	1
Colector admisión	Intake manifold	Collettore aspirazione	8
Tornillos	Bolts	Viti	Standard
Rotación	Rotation	Rotazione	90° V8
Cilindros	Cylinders	Cilindri	Standard
Agujero	Bore	Buco	1-8-4-3-6-5-7-2
Orden encendido	Firing order	Ordine di accensione	5.5 quarts
Capacidad	Oil pan capacity	Coppa l'olio capacità	SAE 15W40 Pennzoil Marine
Tipo aceite	Oil type	Tipo olio	9:4:1
Ratio composición	Composition Ratio	Rapporto di composizione	
Árbol de levas de rodillos hidráulicos	Hydraulic Roller Camshaft	Albero a camme del rullo idraulico	
Tornillo	Bolt Main	Vite	4

Reemplaza Mercuriser, Volvo, OMC y Crusader MPI (1996+) Bomba de combustible eléctrica. Requiere utilizar sensor de posición del cigüeñal. Colector de admisión tipo 8 tornillos con inyección MultiPort.

### EQUIPO STANDARD

Todos los componentes internos  
Tapas válvulas  
Tapa distribución de composite  
Cárter de aceite

Replace Mercuriser, Volvo, OMC and Crusader. MPI Long Block (1996+).  
Electric fuel pump.  
Requires use of crank position sensor.  
8 bolt style MultiPort injection intake manifold

### STANDARD EQUIPMENT

All internal components  
Valve covers  
Composite Timing cover  
Oil Pan

Sostituisce Mercuriser, Volvo, OMC e Crusader. MPI (1996+).  
Pompa benzina elettrica.  
Richiede l'uso sensore di posizione dell'albero motore.  
Collettore aspirazione 8 bulloni con iniezione Multiport.

### CARATTERISTICHE STANDARD

Tutti i componenti interni  
Coperchio punterie  
Carter distribuzione  
Coppa dell'olio

## MODELO MOTOR ENGINE MODEL MODELLO MOTORE

(GM377 MAG) 6.2 L

Ref.	R.O. OEM R.O.
RECGM6.2MPI	Mercuriser: 865108A02



Base motor nueva	Base engine	Base motore nuova	GM 6.2L
Cubicaje	Displacement	Cilindrata	6.2L (350 CID)
Potencia cigüeñal	Horse Power	Potenza all'albero motore	355 HP @ 4500 rpm
Retén cigüeñal	Rear Main seal	Paraolio posteriore albero motore	1
Colector admisión	Intake manifold	Collettore aspirazione	8
Tornillos	Bolts	Viti	

Reemplaza Mercuriser 6.2L MPI desde 1996 en adelante.

Requiere utilizar sensor de posición del cigüeñal. Colector de admisión tipo 8 tornillos con inyección MultiPort.

### EQUIPO STANDARD

Todos los componentes internos  
Tapas válvulas  
Tapa distribución de composite  
Cárter de aceite

Replace Mercuriser 6.2L MPI Long Block from 1996 up today.

Requires use of crank position sensor  
8 bolt style MultiPort injection intake manifold

### STANDARD EQUIPMENT

All internal components  
Valve covers  
Composite Timing cover  
Oil Pan

Sostituisce Mercuriser 6.2L MPI Long Block dal 1996 in avanti.

Richiede l'uso sensore di posizione dell'albero motore  
Collettore d'aspirazione con 8 viti e iniezione MultiPort

### CARATTERISTICHE STANDARD

Tutti i componenti interni  
Coperchio punterie  
Carter distribuzione  
Coppa dell'olio

# BLOQUES Y CULATAS REMANUFACTURADOS GM Y FORD GM & FORD REMANUFACTURED LONG BLOCKS & CYLINDER HEADS ENGINE BLOCKS BLOCCHI E TESTATE RIGENERATI GM E FORD

En FirstMate Marine, su completa satisfacción es nuestro primer y principal interés. Ofrecemos bloques, culatas y conjuntos con cárter y tapa de distribución. Si necesita un motor que no esté en nuestra lista, por favor llámenos. Los números de fundición en bloque y culatas nos ayudarán a suministrarles exactamente sus necesidades.

At FirstMate Marine, your complete satisfaction is our first and foremost concern. We offer long blocks, cylinder head kits, and some long block assemblies with oil pan and timing cover. If you need an engine that is not listed in our catalog, please call us. Cylinder head, and block casting numbers will assist us in supplying your exact needs.

FirstMate Marine, offre blocchi motore, completamente rigenerati, nudi o completi di coppa olio e carter distribuzione. Inoltre fornisce testate complete di molle e valvole, già pronte da montare. Se necessita un motore che non si trova nella lista, non dubiti nel contattarci, i numeri di fusione del blocco e delle testate ci aiuteranno a identificare il modello corretto.

## Características

- 12 meses Garantía limitada
- Pistones y aros nuevos
- Levas y lifters marinos
- Tapones de expansión de latón
- Cojinetes nuevos cigüeñal, biela y levas
- Cadena y piñones distribución nuevas
- Bomba de aceite nueva
- Juego de juntas marinas nuevo
- Bloque rectificado y calibrado
- Cigüeñal reacondicionado
- Bielas reacondicionadas
- Culatas rectificadas
- Muelles de válvulas nuevos
- Prueba de giro
- Prueba de presión

## Engine Features

- 12-month limited warranty
- New pistons, moly rings
- Marine cam and lifters
- Brass block plugs
- New rod, main and cam bearings
- New h.D. Timing chain and gears
- New oil pump
- New marine gasket set
- Block resurfaced, bored and honed
- Crankshaft reconditioned
- Connecting rods reconditioned
- Heads resurfaced
- New valve springs
- Spin tested
- Pressure tested

## Caratteristiche

- 12 mesi Garanzia limitata
- Pistoni e fasce nuove
- Bilancieri e Lifters Marini
- Tappi di dilatazione in bronzo
- Cuscinetti nuovi albero motore
- Catena e pignoni distribuzione nuovi
- Pompa dell'olio nuova
- Kit guarnizioni motore nuove
- Blocco rettificato e calibrato
- Albero motore rigenerato
- Bielle rigenerate
- Testate rigenerate
- Molle valvole nuove
- Testato e fatto girare a motore spento
- Testato e messo in pressione

## IDENTIFICANDO TIPO DE MOTOR BASE GM IDENTIFYING TYPE OF ENGINE BASE GM IDENTIFICAZIONE MODELLO MOTORE BASE GM

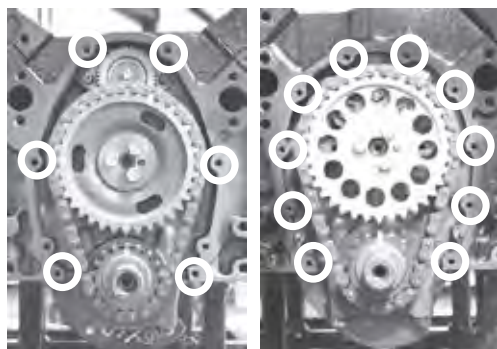
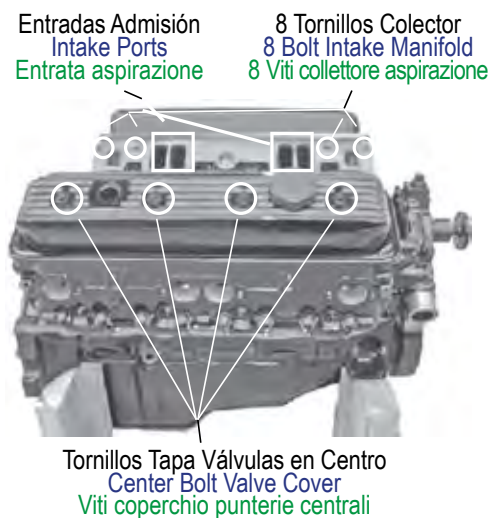
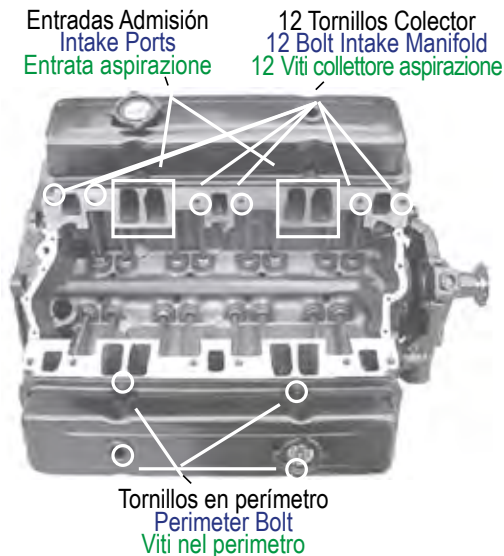

Tapa Distribución  
6 tornillos  
6 Bolt Timing Cover  
Carter distribución  
6 viti

Tapa Distribución  
10 tornillos  
10 Bolt Timing Cover  
Carter distribución  
10 viti

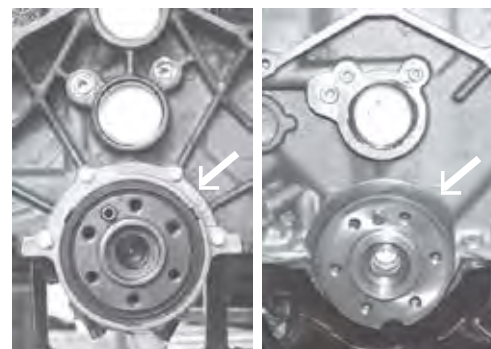

Retén trasero  
1 pieza  
1 Piece. Rear Seal  
Paraolio posteriore  
1 pz

Retén trasero  
2 piezas  
2 Pieces. Rear Seal  
Paraolio posteriore  
2 pz

**IDENTIFICANDO BLOQUE Y CULATA**  
**IDENTIFYING BLOCK & HEAD NUMBERS**  
**IDENTIFICAZIONE BLOCCO E TESTATA**



Bloque FORD  
 Block FORD  
 Blocco FORD



Culatas  
 Heads  
 N.fusione testata



Bloque GM  
 Block GM  
 Blocco GM

**MOTORES REMANUFACTURADOS BASE FORD**  
**REBUILT ENGINES FORD BLOCKS**  
**MOTORI RIGENERATI BASE FORD**

	DESCRIPCIÓN DESCRIPTION DESCRIZIONE	ROTACIÓN STANDARD STANDARD ROTATION ROTAZIONE STANDARD	CULATA CYLINDER HEAD TESTATA	NÚM. DE BLOQUE BLOCK CASTING NUMBER NUMERO BLOCCO	NÚM. DE CULATA CYLINDER HEAD NUMBER NUMERO TESTATA
<b>302 / 5.0L - V8</b>					
1968-81	Modelo antiguo. Número de cigüeñal ha de ser 2M, 2MA, 2MAB. Early style. Crank casting numbers must be 2M, 2MA, 2MAB Modello vecchio. Il numero dell'albero motore deve corrispondere a 2M, 2MA, 2MAB.	FIRFO-302-LA	FIRH6061	D4DE-AA D8YE-A3A D9DE-E3A D5ZY-AA	DOOE D2OE C9TE D34E D44E
1981-95	Bujía Ø 14 mm. Lifters planos. Potencia estimada de 180 a 200 hp. Orden de encendido 1,5,4,2,6,3,7,8. Número de cigüeñal ha de ser 2MAE. Ø 14 mm spark plug. Flat tappets. Crank casting numbers must be 2MAE. Firing order 1,5,4,2,6,3,7,8 Candela Ø 14 mm. Lifter piani. Potenza approssimata da 180 a 200hp. Ordine d'accensione 1,5,4,2,6,3,7,8. Numero albero motore 2MAE.	FIRFO-302-LB	FIRH6062 FIRH6062A	E1AE-AA E5AE E0AE E6SE	E5AE, F3JE-CA D7OE, D8OE DETE E5AE-CA, E5AS, D8AE E7TE, E5TE
1995-98	Motores Inyección y Carburación. Varilla aceite en un lado del motor. Lifters planos. Lleva el árbol de levas del 5.8 (351). Orden de encendido 1,3,7,2,6,5,4,8 Firing order 1,3,7,2,6,5,4,8. Has a 351 camshaft. Flat tappet, Dipstick on side of block. Motori ad iniezione e a carburazione. Asticella dell'olio da un lato del motore. Lifter piani, asse a camme del 5.8 (351). Ordine accensione 1,3,7,2,6,5,4,8	FIRFO-302-LD	FIRH6062 FIRH6062A	F1SE	F3JE-CA, -CE D8OE D7OE-DA E8JL-AA E5AE E7TE, E5TE
<b>351 / 5.8L - V8</b>					
1969-94	Bujía Ø 14 mm. Varilla aceite en el cárter o tapa delantera. Lifters planos. Potencia estimada de 235 a 250hp. Ø 14 mm. spark plug. Flat tappets. Standard 351 engine. Dipstick in pan oil or front cover Candele Ø 14 mm. Asticella dell'olio nella coppa. Lifter piani. Potenza approssimata da 235 a 250hp.	FIRFO-351-LA	FIRH6063 FIRH6064 FIRH6064A	D4AE-AA D4AE-DA D9AE-ED E3AE-BA E4AE	D8OE D7OE-DA E5AE-CA D8OE E5TE, E7TE,
<b>460 / 7.5L - V8</b>					
1978-90	Bujía Ø 14 mm. Lifters planos. Tornillo debajo los balancines. 2 retenes traseros. Potencia estimada de 300 a 340hp. Números de cigüeñal deben ser 3Y o 3YAABC. Ø 14 mm. spark plug. Late style. Crank casting numbers must be 3Y or 3YAABC. Candele Ø 14 mm. Lifter piani. Paraolio posteriore albero motore in 2 pz. Potenza approssimata da 300 a 340hp. Numero dell'albero motore 3Y o 3YAABC.	FIRFO-460-LB	FIRH6065	D9TE	D3VE-A2A D6TE-DA

**MOTORES REMANUFACTURADOS BASE GM**  
**REBUILT ENGINES GM BLOCKS**  
**MOTORI RIGENERATI BASE GM**

	DESCRIPCIÓN DESCRIPTION DESCRIZIONE	ROTACIÓN STAND. STAND. ROTATION ROTAZIONE STAND.	CONTRAROTACIÓN REVERSE ROTATION CONTROROTANTE	CULATA CYLINDER HEAD TESTATA	NÚM. DE BLOQUE BLOCK CASTING NUM. NUM. BLOCCO	NÚM. DE CULATA CYLINDER HEAD NUM. NUM. TESTATA
<b>229 / 3.8L - V6</b>						
1980-84	Lifters planos, varilla en el bloque, retenes traseros de 2 piezas. Potencia estimada de 175hp. Flat tappet, dipstick in block, 2 rear seals. Valve covers bolt around perimeter. Aprox. 175hp. Lifter piani, asticella dell'olio nel blocco, paraolio posteriore albero motore in 2 pz. Potenza approssimata a 175hp.	FIRGM229LA		FIRH6005	471594	471595 14020553

**NOTA**

La letra "T" en la referencia de los bloques de motor significa que vienen con la tapa de distribución, carter, bomba de aceite y tubo de aspiración instalada.

\* últimos dígitos

**NOTE**

The letter "T" in the reference of the engine blocks means that includes: Timing cover, oil pan, oil pump and pickup tube installed.

\* last digits

**NOTA**

La lettera "T" nei blocchi motore, sta a indicare la possibilità di ordinare la versione completa con pompa dell'olio, succhiaria, coppa dell'olio e carter distribuzione già montati.

\* ultimi numeri

	DESCRIPCIÓN DESCRIPTION DESCRIZIONE	ROTACIÓN STAND. STAND. ROTATION ROTAZIONE STAND.	CONTRAROTACIÓN REVERSE ROTATION CONTROROTANTE	CULATA CYLINDER HEAD TESTATA	NÚM. DE BLOQUE BLOCK CASTING NUM. BLOCCO	NÚM. DE CULATA CYLINDER HEAD NUM. NUM. TESTATA
<b>250 / 4.1L - 6 EN LINEA / 4 IN LINE / 4 IN LINEA</b>						
1970-80	Lifters planos, retenes traseros de 2 piezas. Potencia estimada de 160hp. Flat tappet, 2 rear seals. Aprox. 160hp. Lifter piani, paraolio posteriore albero motore in 2 pz. Potenza approssimata a 160hp.	FIRGM250LA		FIRH6007	3850817 473483 377127 366855, *575 348675, *466	3962084 3927763 331184 *052
<b>262 / 4.3L - V6</b>						
1985-86	Retenes traseros de 2 piezas. Tapa de válvulas montada en el centro. Potencia estimada de 175 a 205hp. 2 rear main seals. Central valve cover. Aprox. 175 to 205hp. Paraolio posteriore albero motore in 2 pz. Cop. punterie con viti nel centró. Potenza approssimata da 175 a 205hp.	FIRGM262LA		FIRH6009	14071177	17079268 *107, *476
1986-88	Retenes traseros de 2 piezas. Tapa de válvulas montada en el centro. Potencia estimada de 175 a 205hp. 2 rear main seals. Central valve cover. Aprox. 175 to 205hp. Paraolio posteriore albero motore in 2 pz. Cop. punterie con viti centrali. Potenza approssimata da 175 a 205hp.	FIRGM262LB FIRGM262LBT		FIRH6009	14088553 *683	14079268 14131996 14094768 *107, *476 *103, *066
1987-92	Todos los lifters de rodillos. 1 retén trasero. Tapa válvulas con tornillos en el centro. Potencia estimada de 175 a 205hp. Tapa distribución de 10 tornillos. Colector admisión de 12 tornillos. 1 piece rear main seal. Roller cam engine. 10 bolt Timing cover. 12 bolt intake. Paraolio posteriore in 1 pz. Cop. punterie con viti nel centro. 10 viti nel carter distribuzione e 12 nel collettore aspirazione. Potenza approssimata da 175 a 205hp.	FIRGM262LHT		FIRH6009	14093611 10105867 10066011 *756, *256, *073 *683, *061	14131996 14094768 *107, *476 *103, *066
1992-96	Lifters de rodillos sin eje calibrado. Bomba de combustible eléctrica. Colector admisión de 12 tornillos. Potencia estimada de 175 a 205hp. Roller cam engine with wide intake. 12 bolt intake. Electric fuel pump. Aprox. 175 to 205hp. Motore senza asse equilibrato. Pompa benzina elettrica. Collettore aspirazione con 12 viti. Potenza approssimata da 175 a 205hp.	FIRGM262LFF		FIRH6011	*061, *073, *756	*064, *181 *209, *626
1992-99	Lifter de rodillo con eje calibrado. Tiene 6 ó 10 tornillos en tapa distribución. 14 en carter y 12 en colector de admisión. Roller cam engine with balance shaft. 6 or 10 bolt timing cover, 14 oil pan and 12 intake manifold. Sollevatore rulli con asse equilibrato. 6 o 10 viti nel carter distribuzione. 14 nella coppa dell'olio e 12 nel collettore aspirazione.	FIRGM262LIT		FIRH6011	*196, *359 *534, *535	*181, *209, *064
1996-99	<b>VORTEC.</b> Lifter de rodillo con eje calibrado. Tiene 6 tornillos en tapa distribución, 10 en el cárter de aceite y 8 en el colector de admisión. Roller cam engine with balance shaft 10224542. Has 6 bolt timing cover, 10 bolt oil pan rail and 8 in intake manifold. 175 & 205 hp aprox. <b>VORTEC.</b> Sollevatore rulli con asse equilibrato 10224542. 6 viti nel carter distribuzione, 10 nella coppa dell'olio 8 nel collettore aspirazione.	FIRGM262LGT		FIRH6010	*090	*772, *140
1996-2008	Lifter de rodillo de fundición con eje calibrado. Tiene 6 tornillos en tapa de distribución y 8 en el colector de admisión. Roller cam engine with balance shaft. Has roller rocker casting. Has 6 bolt timing cover and 8 bolt intake manifold. Sollevatore rulli con asse equilibrato. 6 viti nel carter distribuzione e 8 nel collettore aspirazione.	FIRGM262LJT		FIRH6014	*090M	*113
<b>305 / 5.0L - V8</b>						
1976-85	2 piezas reten trasero, tornillos de tapa de válvula montados en el perímetro. Potencia estimada de 200 a 230HP. 2 piece rear main seal. Valve covers bolt around perimeter. 200 & 230 hp aprox. Paraolio posteriore albero motore in 2 pz. Cop. punterie con viti nel perímetro. Potenza approssimata da 200 a 230HP.	FIRGM305LAT	FIRGM305RAT	FIRH6015	14016381 14010203 14010202 14010201 361797 *371, *776, *777 *778, *909, *979	14022601 14022301 14014416 462424 357841 *354, *434, *741
1985-87	Lifters planos, 1 retén trasero, tornillos de tapa de válvula montados en el perímetro. Potencia estimada de 200 a 230hp. With carburetor, 1 piece rear main seal. Valve covers bolt around perimeter. 200 & 230hp aprox. Double check rear main seal. Sollevatore aerei, paraolio posteriore 1 pz. Cop. punterie con viti nel perímetro. Potenza approssimata da 200 a 230hp.	FIRGM305LB FIRGM305LBT	FIRGM305RB	FIRH6015	14102058, 14093627, 14088551, *535	14022601 14022301 14014416 *434, *741 *450, *513, *416
1987-99	12 tornillos en colector admisión, tapa distribución metálica de 10 tornillos, 1 retén trasero, Tapa de válvulas con tornillos montados en el centro. 1 piece rear main seal. Valve covers bolt down center. 10 bolt metal timing cover. 12 bolt intake. 12 viti nel collettore aspirazione, Carter distribuzione in metallo, fissato con 10 viti. Copèrchio punterie con viti nel centro, paraolio posteriore 1 pz	FIRGM305LCT	FIRGM305RC	FIRH6017A	14102058 14093627 14088551, *535	*081 Deben cambiarse las dos culatas Must be replaced both Cylinder Heads Essi devono essere modificate le due testate
1987-99	Con 10 tornillos en tapa de distribución de plástico. 12 tornillos en colector de admisión. 10 bolt plastic timing cover. 12 bolt intake. 200 & 230 hp aprox. Carter distribuzione in plastica fissato con 10 viti. 12 viti nel collettore aspirazione	FIRGM305LD		FIRH6017A	14102058 14093627 14088551, *535	*187 *081 Deben cambiarse las dos culatas Must be replaced both Cylinder Heads Essi devono essere modificate le due testate
1996+	<b>VORTEC.</b> Retén trasero 1 pieza. Con 8 tornillos en colector de admisión. Tapa de distribución de plástico de 10 tornillos. 1 piece rear main seal. 8 bolt intake. 10 bolt Plastic timing cover. <b>VORTEC.</b> Paraolio posteriore 1 pz. 8 viti nel collettore aspirazione. Carter distribuzione in plastica con 10 viti.	FIRGM305LFT		FIRH6018	*878, *880	*620, *059, *520

	DESCRIPCIÓN DESCRIPTION DESCRIZIONE	ROTACIÓN STAND. STAND. ROTATION ROTAZIONE STAND.	CONTRAROTACIÓN REVERSE ROTATION CONTROROTANTE	CULATA CYLINDER HEAD TESTATA	NÚM. DE BLOQUE BLOCK CASTING NUM. BLOCCO	NÚM. DE CULATA CYLINDER HEAD NUM. NUM. TESTATA
<b>350 / 5.7L - V8</b>						
1967-85	Varilla en la parte derecha o izquierda del bloque. 2 piezas retén trasero. Tornillos de tapa de válvula montados en el perímetro. Potencia estimada de 260 hp. 2 piece rear main seal. Valve covers bolt around perimeter. 4 bolt main. 260 hp aprox. Asticella dell'olio nella parte sinistra del blocco. paraolio posteriore 2 pz. Coperchio punterie con viti nel perímetro. Potenza approssimata 260 hp.	FIRGM350LAF	FIRGM350RAF	FIRH6022	*245, *379, *010, *014, *678, *388, *618	*993, *624, *882, *487
		FIRGM350LAF	FIRGM350RAF	FIRH6022		
1986-87	1 retén trasero. Tornillos de tapa de válvulas montados en perímetro. Potencia estimada de 260 hp. 1 piece rear main seal. Valve covers bolt around perimeter. 2 bolt main. 260 hp aprox. Paraolio posteriore 1 pz. Coperchio punterie con viti nel perímetro. Potenza stimata 260hp.	FIRGM350LBF	FIRGM350RBF	FIRH6022	14101148 14093638 14088548 10054727, *526	*993, *624, *882, *487
		FIRGM350LBF	FIRGM350RBF	FIRH6022		
1988-95	12 tornillos colector de admisión, 1 retén trasero, tornillos de tapa de válvula montados en el centro. Tapa de distribución de metal. Potencia estimada de 260 hp. 1 piece rear main seal. Valve covers bolt down center. 2 bolt main. Has metal timing cover. 12 bolt intake. 260 hp aprox. 12 viti nel collettore aspirazione, paraolio posteriore 1 pz. Coperchio punterie con viti nel centro, carter distribuzione in metallo. Potenza stimata 260 hp.	FIRGM350LCT	FIRGM350RCT	FIRH6023	14101148 14093638 14088548 10054727, *526	*193, *083, *217
1995-99	1 retén trasero, 12 tornillos colector de admisión. Tapa de distribución de plástico con 6 tornillos. Lifters de rodillo. Bomba de gasolina mecánica o eléctrica. Potencia aprox 260 hp. 1 piece rear main seal. Roller cam. 6 bolt timing cover plastic. Mechanical or electric fuel pump. 12 bolt intake. 260 hp aprox. Paraolio posteriore 1 pz, 12 viti collettore aspirazione, carter distribuzione in plastica fissato con 6 viti. Sollevatore rulli, predisposto per pompa benzina meccanica (monta anche l'elettrica). Potenza approssimata 260 HP.	FIRGM350LET		FIRH6023 No Vortec	*880	*193, *083, *217
1996+	1 retén trasero, 8 tornillos colector de admisión, Tapa de distribución de plástico con 6 tornillos. Bomba de gasolina mecánica o eléctrica. Potencia estimada de 260 HP. 1 piece rear main seal. 6 bolt timing cover plastic. 8 bolt intake. Mechanical or electric fuel pump. 260 hp aprox. Paraolio posteriore 1 pz, 8 viti collettore aspirazione. Carter distribuzione in plastica fissato con 6 viti predisposto per pompa benzina meccanica (monta anche l'elettrica). Potenza approssimata 260 HP.	FIRGM350LFT		FIRH6013 Vortec	*880	*906, *062
<b>454 / 7.4L - V8</b>						
1973-90	Toma de admisión ovalada, bloque IV Generación, tomas de entrada pequeñas 1-5/8", 2 piezas reten trasero. Tapa de distribución de 10 tornillos 2 piece rear main seal. Oval intake port heads. Block IV Generation, 10 bolt timing cover. Flat tapped. Fori d'aspirazione ovali, blocco generazione IV entrate 1-5/8", paraolio posteriore 2 pezzi. Carter distribuzione con 10 viti.	FIRGM454LAST	FIRGM454RA FIRGM454RAT		14005445 3999293 3999289 3963512 3916321 361959 14005445 *286, *289*775	6272292 353049 336781 14081045 14092360 348236 6272292 353049 336781, *186, *039, *416
1991-97	Bloque V generación, toma de admisión ovalada, lifters planos, 1 retén trasero. Tapa de distribución de 10 tornillos 1 piece rear main seal. Oval intake port heads. 10 bolt timing cover. Fori d'aspirazione ovali, blocco generazione V, Sollevatore aerei, Paraolio posteriore 1 pz. Carter distribuzione con 10 viti.	FIRGM454LB FIRGM454LBT	FIRGM454RB FIRGM454RBT	FIRH6033	10114182 *297, 313	10114156 *932
1991-97	Bloque V generación, H.O Series (Magnum), 1 retén trasero, 10 tornillos en la tapa de distribución. Potencia estimada de 360 HP. 1 piece rear main seal. 10 bolt timing cover 360 hp aprox. Blocco V generazione, H.O Serie (Magnum), paraolio posteriore 1 pz. Carter distribuzione con 10 viti. Potenza approssimata 360HP.	FIRGM454LCT		FIRH6033	*182	*156, *932
1996-99	Bloque VI generación, 1 retén trasero. Lifter de rodillo, 6 tornillos en tapa de distribución. Bomba de combustible eléctrica. Potencia estimada de 330 hp. 1 piece rear main seal. Roller cam engine. Gen VI, 6 bolt timing cover. Electric fuel pump. 330 hp aprox. Blocco VI generazione, paraolio posteriore 1 pz. Sollevatore rulli, Carter distribuzione con 6 viti. Pompa benzina elettrica. potenza approssimata 330hp.	FIRGM454LD FIRGM454LDT		FIRH6036	*297, 313	*279
1996-03	Bloque VI generación, 1 retén trasero, 6 tornillos en tapa de distribución. Potencia estimada de 330 hp. 1 piece rear main seal. Gen VI, 6 bolt timing cover. Blocco VI generazione, paraolio posteriore 1 pz. Carter distribuzione con 6 viti. Potenza approssimata 330hp.	FIRGM454LH		FIRH6033	*297	*156, 932
<b>496 / 8.1L - V8</b>						
2000-11	VORTEC. No H.O. Potencia 375 hp. VORTEC. Not for H.O. 375 hp. VORTEC. No H.O. Potencia 375 hp.	FIRGM4960CT			*110	*162
2000-11	VORTEC. Sólo H.O. Potencia 420 hp. VORTEC. Only for H.O. 420 hp. VORTEC. Sólo H.O. Potencia 420 hp.	FIRGM4961CT			*110	*162

**NOTA**

La letra "T" en la referencia de los bloques de motor significa que vienen con la tapa de distribución, carter, bomba de aceite y tubo de aspiración instalada.  
\* últimos dígitos

**NOTE**

The letter "T" in the reference of the engine blocks means that includes: Timing cover, oil pan, oil pump and pickup tube installed.  
\* last digits

**NOTA**

La lettera "T" nei blocchi motore, sta a indicare la possibilità di ordinare la versione completa con pompa dell'olio, succhiarella, coppa dell'olio e carter distribuzione già montati.  
\* ultimi numeri



# BLOQUE MOTOR GENERAL MOTORS ENGINE BLOCK GENERAL MOTORS BLOCCO MOTORE GENERAL MOTORS

181 CID, 3.0L & 250 CID, 4.1L

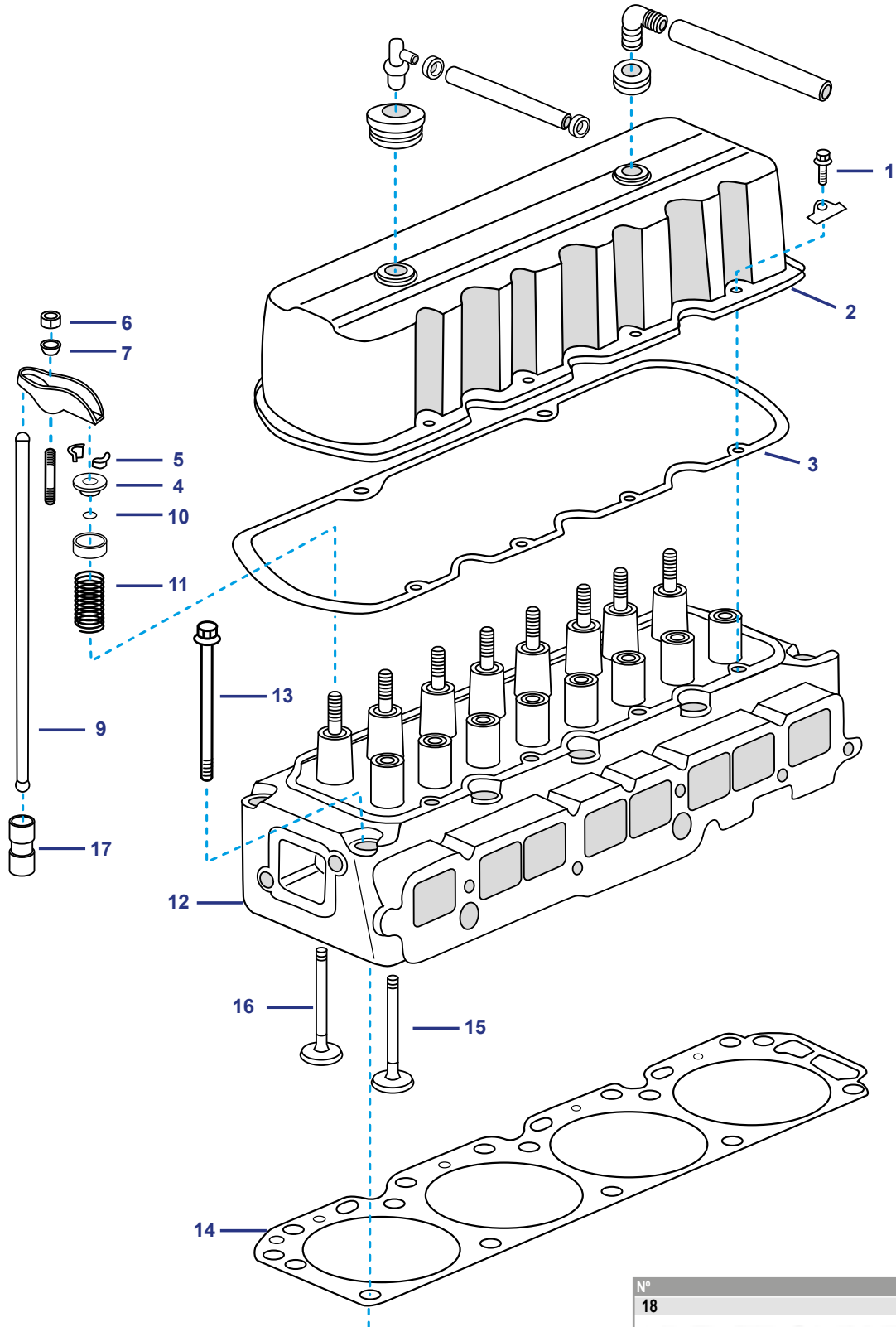

N°  
18



Juntas admisión / escape  
Intake / exhaust gasket  
Guarnizione aspirazione / scarico

Nº	R.O. / OEM VOLVO	R.O. / OEM MERCUISER	Ref.	Descripción	Description	Descrizione	Cantidad Quantity Quantità
1	3853503	10-65746	MP0025-107	TORNILLO, TAPA VÁLVULA	BOLT: VALVE COVER	VITE, COPERCHIO VALVOLA	5
2	3853784	851036T	MP0014-100	TAPA VÁLVULA: 3.0L	VALVE COVER: 3.0L	COPERCHIO VALVOLA: 3.0L	1
3	3852693	27-851040	FEL17900	JUNTA: TAPA VÁLVULA 3.0L	GASKET: VALVE COVER 3.0L	GUARNIZIONE: COPERCHIO VALVOLA 3.0L	5
3		27-49936	FEL17925	JUNTA: TAPA VÁLVULA 4.1L	GASKET: VALVE COVER 4.1L	GUARNIZIONE: COPERCHIO VALVOLA 4.1L	1
4	3853129	F11100604		ROTOR: VÁLVULA 181	ROTATOR: VALVE 181	ROTORE: VALVOLA 181	4
5	3855823	28-54797 1		CHAVETA VÁLVULA 3.0L	KEY: VALVE STEM 3.0L	CHIAVETTA: VALVOLA 3.0L	8
6	3857665	11-34516		TUERCA: VÁLVULA BRAZO DEL BALANCÍN 3.0L & 4.1L	NUT: VALVE ROCKER ARM 3.0L & 4.1L	DADO: VALVOLA BILANCERE 3.0L & 4.1L	8
7		59340	RM59340	BOLA: VÁLVULA BRAZO DEL BALANCÍN 3.0L & 4.1L	BALL: VALVE ROCKER ARM 3.0L & 4.1L	SFERA: VALVOLA BILANCERE 3.0L & 4.1L	8
9	3857899	34532	REC12001	VARILLA: 3.0L & 4.1L	PUSH ROD: 3.0L & 4.1L	ASTA: 3.0L & 4.1L	8
10	3854956	26-34217	REC26-34217	RETÉN: VÁLVULA ACEITE 3.0L & 4.1L	SEAL: VALVE STEM OIL 3.0L & 4.1L	TENUTA: VALVOLA OLIO 3.0L & 4.1L	8
11	3857898	24-35214	REC11501	MUELLE: VÁLVULA 3.0L & 4.1L	SPRING: VALVE 3.0L & 4.1L	MOLLA: VALVOLA 3.0L & 4.1L	8
12		937-4287	FIRH6007	CULATA REMANUFACT. 4.1L	REMANUFAC. CYL. HEAD 4.1L	TESTATA RIFABBRICATA 4.1 L	1
13	3857900	10-34510	REC10501	TORNILLO: CULATA	BOLT: CYLINDER HEAD	VITE: TESTATA	10
14	3853336	27-52364	FEL17000	JUNTA: CULATA 181 (3.0L)	GASKET: CYLINDER HEAD 181 (3.0L)	GUARNIZIONE TESTATA 181 (3.0L)	1
14		24-47453	FEL17019	JUNTA : CULATA 4.1L	GASKET: CYLINDER HEAD 4.1L	GUARNIZIONE TESTATA 4.1L	1
15		34528	REC13500	VÁLVULA ESCAPE 4.1L (38-8.5-125.5)	VALVE: EXHAUST 4.1L (38-8.5-125.5)	VALVOLA SCARICO 4.1L (38-8.5-125.5)	4
15	3853127	52367	REC13501	VÁLVULA ESCAPE 3.0L (40.7-8.7-125)	VALVE: EXHAUST 3.0L (40.7-8.7-125)	VALVOLA SCARICO 3.0L (40.7-8.7-125)	4
15	856368	85803	REC13502	VÁLVULA ESCAPE 2.5L (38.1-8.7-125)	VALVE: EXHAUST 2.5L (38.1-8.7-125)	VALVOLA SCARICO 2.5L (38.1-8.7-125)	4
16		62421	REC13503	VÁLVULA: ADMISIÓN 4.1L (43.7-8.7-125)	VALVE: INTAKE 4.1L (43.7-8.7-125)	VALVOLA ASPIRAZIONE 4.1L (43.7-8.7-125)	4
16	3857879	97661	REC13504	VÁLVULA: ADMISIÓN 3.0L (49.3-8.7-124)	VALVE: INTAKE 3.0L (49.3-8.7-124)	VALVOLA ASPIRAZIONE 3.0L (49.3-8.7-124)	4
16		62421	REC13503	VÁLVULA: ADMISIÓN 2.5L (43.7-8.7-125)	VALVE: INTAKE 2.5L (43.7-8.7-125)	VALVOLA ASPIRAZIONE 2.5L (43.7-8.7-125)	4
17	3853954	72638	REC14000	EMPUJADOR VÁLVULA	LIFTER: VALVE	ALZA VALVOLA	8
18		27-52546	FEL17300	JUNTAS ADMISIÓN / ESCAPE 2.5L	INTAKE / EXHAUST GASKET 2.5L	GUARNIZ. ASPIRAZIONE / SCARICCO 2.5L	1
18		27-53354	FEL17301	JUNTAS ADMISIÓN / ESCAPE 181	INTAKE / EXHAUST GASKET 181	GUARNIZ. ASPIRAZIONE / SCARICCO 181	1
18		27-96429	FEL17302	JUNTAS ADMISIÓN / ESCAPE 3.0L (NO LX)	INTAKE / EXHAUST GASKET 3.0L (NOT LX)	GUARNIZ. ASPIRAZIONE / SCARICCO 3.0L (NO LX)	1
18	3853256	27-815528	FEL17304	JUNTAS ADMISIÓN / ESCAPE 3.0LX (1991+)	INTAKE / EXHAUST GASKET 3.0LX (1991+)	GUARNIZ. ASPIRAZIONE / SCARICCO 3.0LX (1991+)	1
18		27-46401	FEL17319	JUNTAS ADMISIÓN / ESCAPE 4.1L	INTAKE / EXHAUST GASKET 4.1L	GUARNIZ. ASPIRAZIONE / SCARICCO 4.1L	1

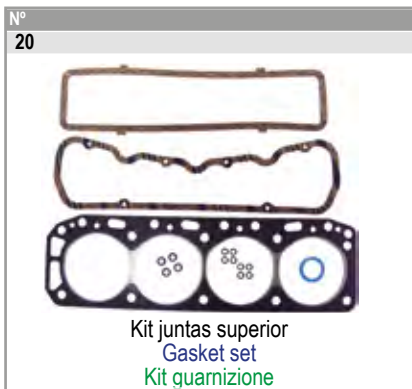
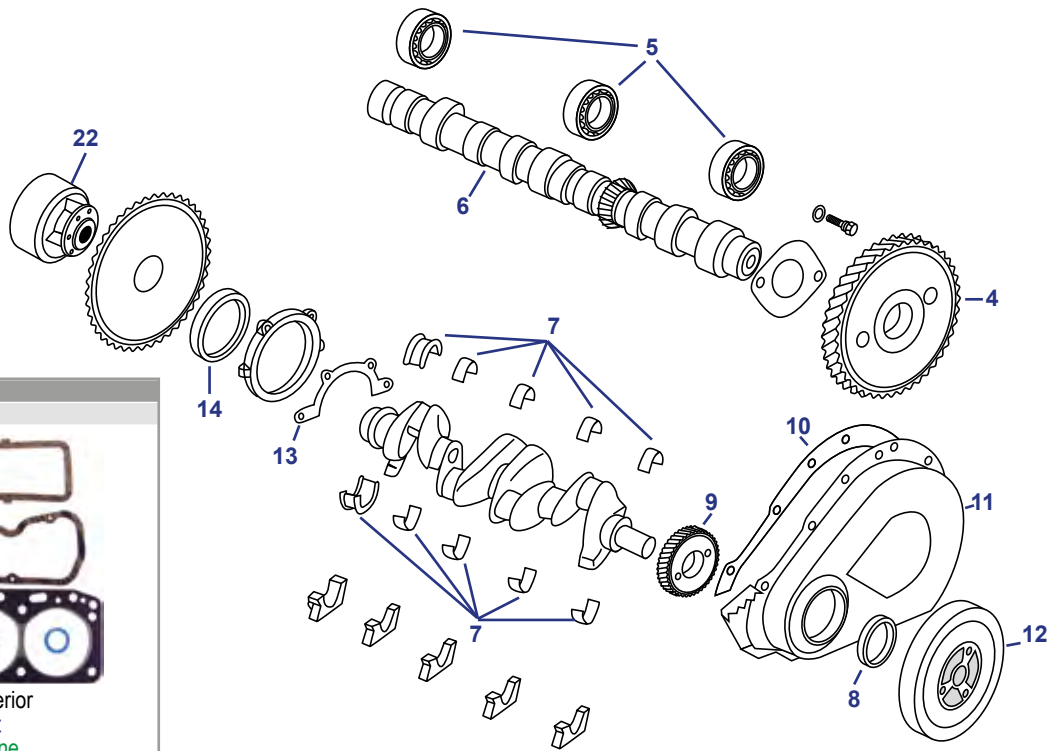
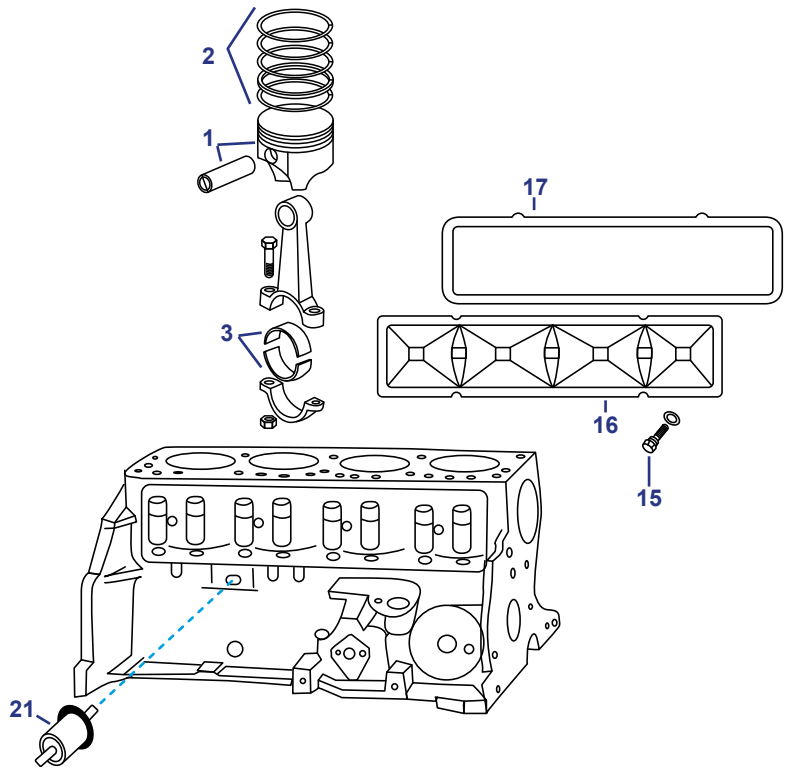
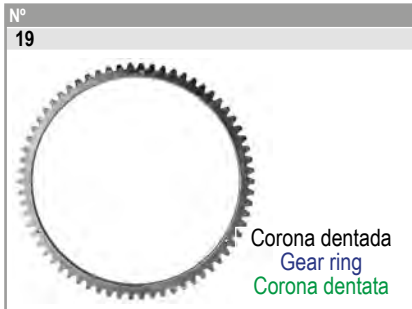
**181 CID, 3.0L & 250 CID, 4.1L**



Nº	R.O. / OEM VOLVO	R.O. / OEM MERCURUISER	Ref.	Descripción	Description	Descrizione	Cantidad Quantity Quantità
1		733-803850T	REC10001	PISTÓN: 181 RX 3.0L STD	PISTON: 181 RX 3.0L STD	PISTONE: 181 RX 3.0L STD	4
1	3853477	733-38181	REC10016	PISTÓN: 181 RX 3.0L 0.20	PISTON: 181 RX 3.0L 0.20	PISTONE: 181 RX 3.0L 0.20	4
1	3853340	733-810852	RM733-810852	PISTÓN: 181 3.0LX STD	PISTON: 181 3.0LX STD	PISTONE: 181 3.0LX STD	4
1		734-4858	REC10002	PISTÓN: 4.1L STD	PISTON: 4.1L STD	PISTONE: 4.1L STD	6
1		734-4860	REC10003	PISTÓN: 4.1L 0.30	PISTON: 4.1L 0.30	PISTONE: 4.1L 0.30	6
2		39-17464	REC11007	KIT AROS: PISTÓN 181 3.0L STD	RING SET: PISTON 181 RX 3.0L	KIT ANELLI: PISTONE 181 RX 3.0L	4
2		39-66217	REC11008	KIT AROS: PISTÓN 181 3.0L 0.20	RING SET: PISTON 181 RX 3.0L 0.20	KIT ANELLI: PISTONE 181 RX 3.0L 0.20	4
2	3853960	39-17464	REC11001	KIT AROS: PISTÓN 181 3.0LX STD	RING SET: PISTON 181 3.0LX STD	KIT ANELLI: PISTONE 181 3.0LX STD	4

Nº	R.O. / OEM VOLVO	R.O. / OEM MERCURISER	Ref.	Descripción	Description	Descrizione	Cantidad Qty Quantità
2		39-67132	REC11002	KIT AROS: PISTÓN 4.1L STD	RING SET: PISTON 4.1L STD	KIT ANELLI: PISTONE 4.1L STD	6
2		39-67134	REC11003	KIT AROS: PISTÓN 4.1L 0.30"	RING SET: PISTON 4.1L 0.30	KIT ANELLI: PISTONE 181 0.30	6
3	3853149	23-85701	REC13001	COJINETE BIELA 3.0L & LX STD	BEARING: CONNECTING ROD 3.0L & LX STD	CUSCINETTO BIELLA 3.0L & LX STD	4
3	3856117	23-85704	REC13002	COJINETE BIELA 3.0L & LX 0.10" / 0.25 mm	BEARING: CONNECTING ROD 3.0L & LX 0.10" / 0.25 mm	CUSCINETTO BIELLA 3.0L & LX 0.10" / 0.25 mm	4
3	3853153	23-85705	REC13024	COJINETE BIELA 3.0L & LX 0.20" / 0.51 mm	BEARING: CONNECTING ROD 3.0L & LX 0.20" / 0.51 mm	CUSCINETTO BIELLA 3.0L & LX 0.20" / 0.51 mm	4
3	3858954	23-804982	RM23-804982	COJINETE BIELA 3.0LX & GS (Ancho 19 mm )	BEARING: CONNECTING ROD 3.0LX & GS (Width 19 mm )	CUSCINETTO BIELLA 3.0LX & GS (Larghezza 19 mm)	4
3		23-85677	REC13003	COJINETE BIELA 4.1L STD	BEARING: CONNECTING ROD 4.1L STD	CUSCINETTO BIELLA 4.1L STD	4
3		23-85680	REC13004	COJINETE BIELA 4.1L 0.10" / 0.25 mm	BEARING: CONNECTING ROD 4.1L 0.10" / 0.25 mm	CUSCINETTO BIELLA 4.1L 0.10" / 0.25 mm	4
4	3852452	43-46745	REC15001	ENGRANAJE: ÁRBOL DE LEVAS (54 dientes)	GEAR: CAMSHAFT (54 Teeth)	INGRANAGGIO: ALBERO A CAMME (54 denti)	1
5	3852829	23-43293T	REC13005	COJIENTE: ÁRBOL DE LEVAS (Kit de 3)	BEARING: CAMSHAFT (Set of 3)	CUSCINETTO ALBERO A CAMME (Kit de 3)	1
6	3852262	424-3864	REC16001	ÁRBOL DE LEVAS: 181 RX	CAMSHAFT: 181 RX	ALBERO A CAMME: 181 RX	1
7	3856731	23-818469001	REC13006	KIT COJINETE: CIGÜEÑAL 3.0L STD	BEARING KIT: CRANK-SHAFT 3.0L STD	KIT CUSCINETTO: ALBERO MOTORE 3.0L STD	1
7		23-818471	REC13007	KIT COJINETE: CIGÜEÑAL 3.0L 0.10" / 0.25 mm	BEARING KIT: CRANKSHAFT 3.0L 0.10" / 0.25 mm	KIT CUSCINETTO: ALBERO MOTORE 3.0L 0.10" / 0.25 mm	1
7		23-818472	REC13026	KIT COJINETE: CIGÜEÑAL 3.0L 0.20" / 0.51 mm	BEARING KIT: CRANKSHAFT 3.0L 0.20" / 0.51 mm	KIT CUSCINETTO: ALBERO MOTORE 3.0L 0.20" / 0.51 mm	1
7		23-85675	REC13008	KIT COJINETE: CIGÜEÑAL 4.1L STD	BEARING KIT: CRANK-SHAFT 4.1L STD	KIT CUSCINETTO: ALBERO MOTORE 4.1L STD	1
7		23-85713	REC13009	KIT COJINETE: CIGÜEÑAL 4.1L 0.10" / 0.25 mm	BEARING KIT: CRANKSHAFT 4.1L 0.10" / 0.25 mm	KIT CUSCINETTO: ALBERO MOTORE 4.1L 0.10" / 0.25 mm	1
8	3853341	26-97335	REC3853341	RETÉN	SEAL OIL	PARAOILIO	1
9		43-46743	REC15003	ENGRANAJE CIGÜEÑAL 181 RX (27 Dientes)	GEAR: CRANKSHAFT 181 RX (27 Teeth)	INGRANAGGIO ALBERO MOTORE 181 RX (27 denti)	1
10	3852691	27-49953	REC27-49953	JUNTA: TAPA DISTRIBUCIÓN	GASKET: DISTRIBUTOR CAP	GUARNIZIONE: COPPERCHIO DISTRIBUZIONE	1
11	3853135	59341A1	REC59341A1	TAPA: DISTRIBUIDOR 181	COVER: TIMING 181	COPPERCHIO: DISTRIBUZIONE 181	1
12	3852662	55045T	MP0025-004	BALANCÍN: HARMONIC 181	BALANCER: HARMONIC 181	BILANCERE: HARMONIC 181	1
13	3852656	27-881715	REC27-14241	JUNTA PORTA RETÉN	GASKET	PARAOILIO	1
14	3852657	26-14240	REC26-14240	RETÉN: CIGÜEÑAL RR	SEAL OIL: CRANKSHAFT RR	PARAOILIO: ALBERO MOTORE RR	1
15	3853955	10-34470	MP0014-403	TORNILLO	BOLT	VITE	4
16	3853138	814702	MP0014-401	TAPA	COVER	COPPERCHIO	1
17	3856443	27-814703	FEL17903	JUNTA	GASKET	GUARNIZIONE	1
17		27-34209	FEL17926	JUNTA: VÁLVULA 4.1L	GASKET: VALVE PUSH ROD COVER 4.1L	GUARNIZIONE: VALVOLA 4.1L	1
18		220-801873	REC095009	VOLANTE 12-3/4"	FLYWHEEL 12-3/4"	VOLANTE 12-3/4"	1
19			REC157-N	CORONA DENTADA (157 dientes Ø12")	GEAR RING (157 Teeth Ø 12")	CORONA DENTATA (157 denti Ø12")	1
19	3853143		REC1685	CORONA DENTADA (168 dientes Ø13-3/4")	GEAR RING (168 Teeth Ø 13-3/4")	CORONA DENTATA (168 denti Ø13-3/4")	1
19			FED416-124	CORONA DENTADA (180 dientes Ø14-1/2")	GEAR RING (180 Teeth Ø14-1/2")	CORONA DENTATA (180 denti Ø14-1/2")	1
20			FEL17200	KIT JUNTAS 2.5L / 3.0L (4L) (excluidas admisión)	GASKET SET 2.5L / 3.0L (4L) (Excluded Intake Gasket)	KIT GAURNIZIONE 2.5L / 3.0L (4L) (Esclusi aspirazione)	1
20			FEL17219	KIT JUNTAS 4.1L (6L) (excluidas admisión)	GASKET SET 4.1L (6 In Line) (Excluded Intake Gasket)	KIT GAURNIZIONE 4.1L (6L) (Esclusi aspirazione)	1
21	3857532	8M0068784	REC8M0068784	SENSOR PRESIÓN DE ACEITE	OIL PRESSURE SENDER	SENSORE PRESSIONE DELL'OLIO	1
22				ACOPLAMIENTO	DAMPER	ACCOPIAMENTO	

**181 CID, 3.0L & 250 CID, 4.1L**

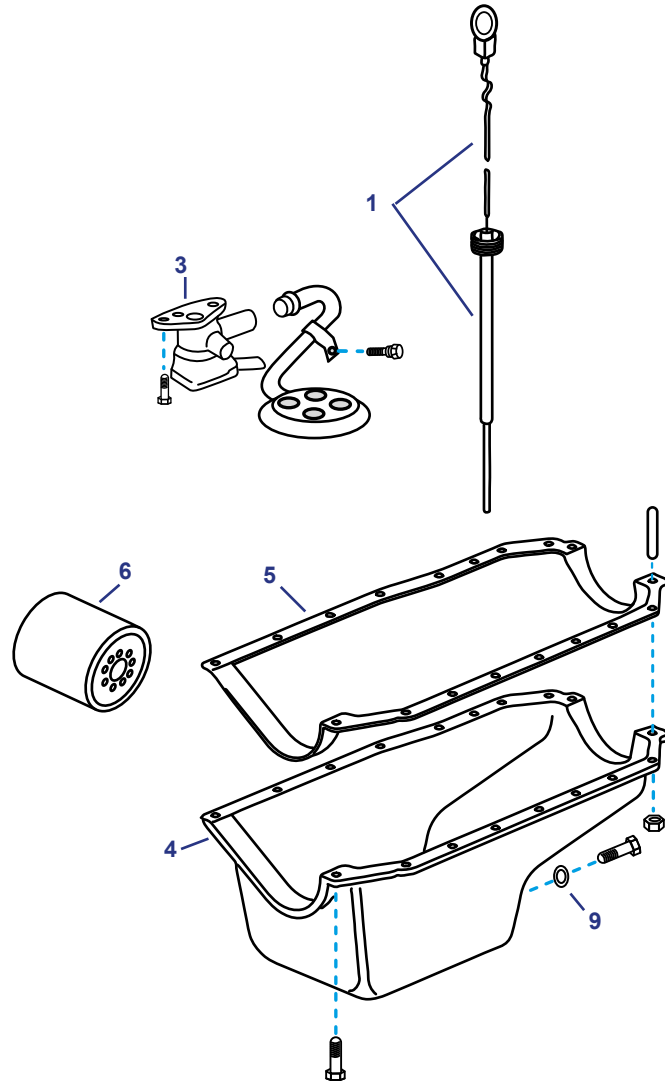
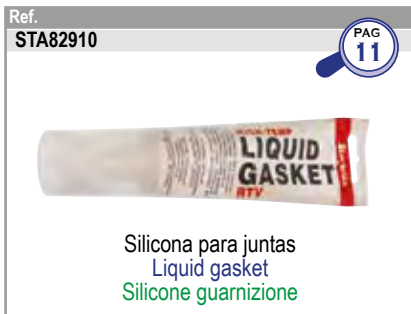

Nº	R.O. / OEM VOLVO	R.O. / OEM MERCURISER	Ref.	Descripción	Description	Descrizione	Cantidad Quantity Quantità
1			MP0314-002	VARILLA + TUBO ACEITE 181	DIPSTICK + TUBE 181 OIL	ASTA + TUBO OLIO 181	1
3	3853843	36405	REC14100	BOMBA ACEITE: 181 RX	PUMP: 181 RX OIL	POMPA OLIO: 181 RX	1
4	3854015	810845T	RM810845	CÁRTER 181 3.0L Y 3.0 LX, MPI, TKS (1990+)	OIL PAN 181 3.0L & 3.0 LX, MPI, TKS (1990+)	COPPA OLIO 181 3.0L E 3.0 LX, MPI, TKS (1990+)	1
5		27-52144	FEL17950	JUNTA CÁRTER 4 PIEZAS	GASKET OIL PAN 4 Pcs.	GUARNIZIONE: COPPA OLIO 4 PEZZI	1
5	3853343	27-810846	FEL17952	JUNTA CÁRTER 3.0L (retén trasero 1 pieza)	GASKET OIL PAN 3.0L (1 Piece rear seal)	GUARNIZIONE COPPA OLIO 3.0L (tenuta posteriore 1 pezzo)	1
5		27-49949	FEL17975	JUNTA CÁRTER 4.1L	GASKET OIL PAN 4.1L	GUARNIZIONE COPPA OLIO 4.1L	1
6				FILTRO ACEITE	FILTER OIL	FILTRO OLIO	1
7			FEL17100	KIT JUNTAS 3.0L (4 juntas cárter, retén trasero 2 piezas)	GASKET SET 3.0L (4 oil pan gaskets 2 pcs. rear seal)	KIT GUARNIZIONE 3.0L (4 guarniz. coppa olio, tenuta posteriore 2 pezzi)	1
7		32-865277	FEL17102	KIT JUNTAS 3.0L (1 junta cárter, 1 retén trasero)	GASKET SET 3.0L (1 oil pan gasket 1 pc. rear seal)	KIT GUARNIZIONE 3.0L (1 guarniz. coppa olio, 1 tenuta posteriore)	1
7			FEL17119	KIT JUNTAS 4.1L 24 TORNILLOS (Cárter 16 tornillos, utilizar sellante STA82910)	GASKET SET 4.1L 24 BOLTS (16 bolt oil pan, use sellant STA82910)	KIT GUARNIZIONE 4.1L 24 VITI (Coppa olio 16 viti, Usare il sigillante STA82910)	1
8	3854956	26-34217	MPI305-0380	MANGUERA DE VACIADO MCM-OMC 1/2"	DRAIN HOSE MCM-OMC 1/2"	TUBO DI SCARICO MCM-OMC 1/2"	1
8	3857898	24-35214	MPI307-0380	MANGUERA DE VACIADO VOLVO 3/4"	DRAIN HOSE VOLVO 3/4"	TUBO DI SCARICO VOLVO 3/4"	1
9	3851981	27-49955	REC27-49955	JUNTA	GASKET	GUARNIZIONE	1

# 181 CID, 3.0L

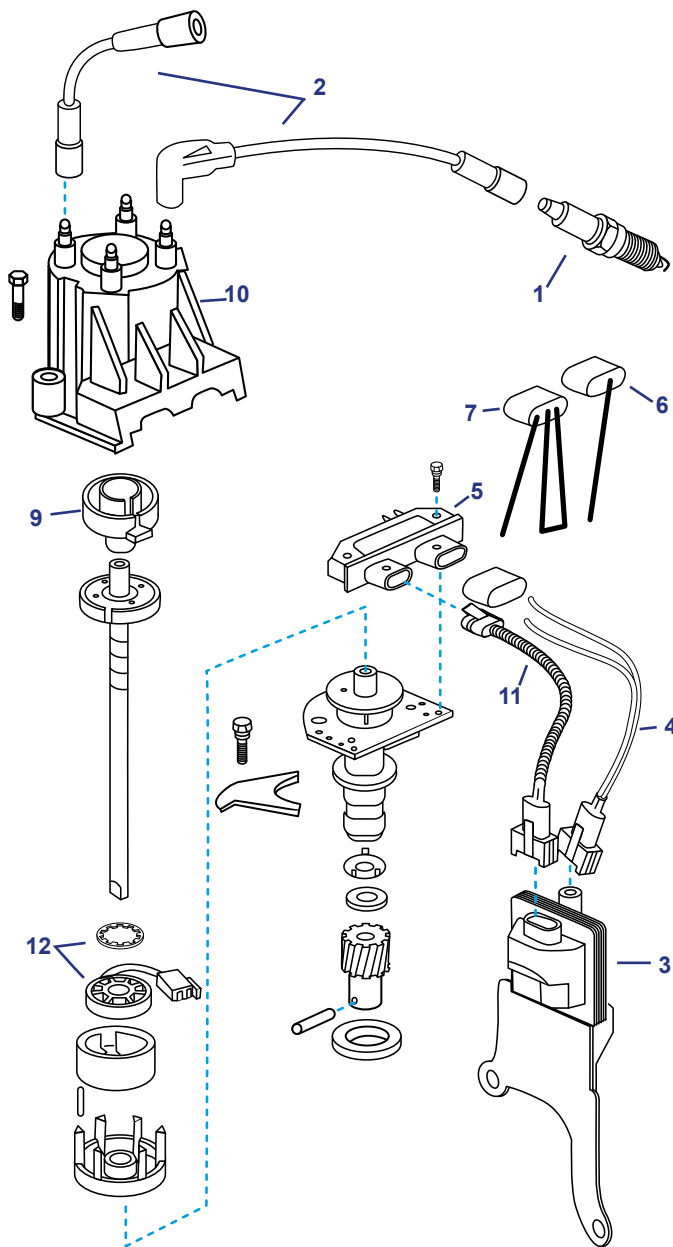

Nº 8  
Distribuidor electrónico  
Distributor: Electronic  
Distribuzione electronic



Para otros modelos consultar:  
For other models see:  
Per altri modelli vedi:

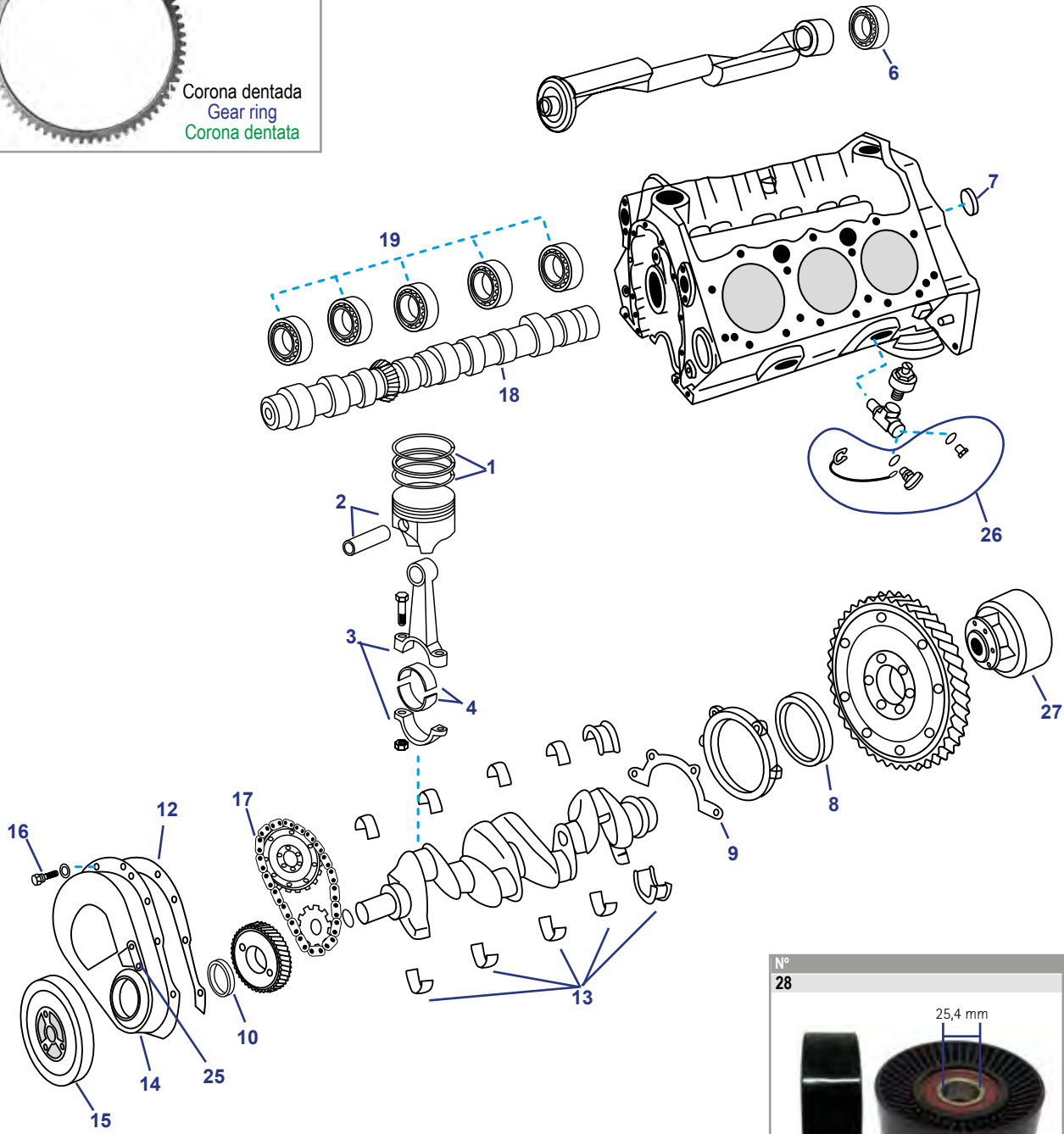
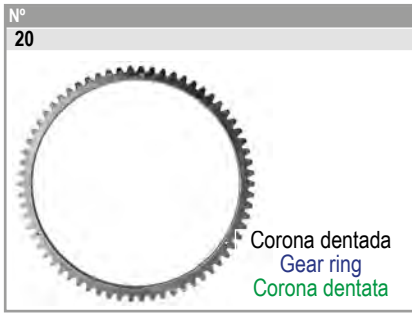

Nº	R.O. / OEM VOLVO	R.O. / OEM MERCURUISER	Ref.	Descripción	Description	Descrizione	Cantidad Quantity Quantità
1		45490		BUJÍA: 181	SPARK PLUG: 181	CANDELE: 181	4
2	3888324	84-816761Q14	<b>REC15-405</b>	KIT CABLES ARRANQUE: 181	IGNITION WIRE SET: 181	KIT CAVI ACCENSIONE: 181	1
3	3854002	898253T27	<b>REC3854002</b>	BOBINA: DELCO	COIL: DELCO	BOBINA: DELCO	1
4			<b>REC500442</b>	CABLE: BOBINA DISTRIBUIDOR	WIRE LEAD: COIL TO DIST.	CAVI: BOBINA DISTRIBUZIONE	1
5	3854003	811637001	<b>REC3854003</b>	MÓDULO: DISTRIBUIDOR DELCO	MODULE: DISTRIBUTOR DELCO	MODULO DISTRIBUZIONE DELCO	1
6		807964A1	<b>REC294005</b>	CABLE ARRANQUE: INTERRUPTOR	IGNITION WIRE: SHIFT INTERUPTER	CAVO ACCENSIONE: INTERRUPTORE	1
7	885163	91-888863	<b>REC91-888863</b>	PUENTE DE DISTRIBUCIÓN	TIMING JUMPER: IGNITION	PONTE DI DISTRIBUZIONE	1
8		817377	<b>REC817377</b>	DISTRIBUIDOR ELECTRÓNICO 181 (5, 9 y 10 incluidos)	DISTRIBUTOR: ELECTRONIC 181 (5, 9 & 10 Included)	DISTRIBUZIONE ELECTRONIC 181 (include 5, 9 e 10)	1
9	3854261	8M6001254	<b>REC3854261</b>	ROTOR DISTRIBUIDOR 181 RX	ROTOR: DISTRIBUTOR 181 RX	ROTORE: DISTRIBUZIONE 181 RX	1
10	3854260	811635T3	<b>REC3854260</b>	TAPA DISTRIBUIDOR 181 RX	CAP: DISTRIBUTOR 181 RX	COPERCHIO DISTRIBUZIONE 181 RX	1
11	3854084	84-817376T01	<b>REC84- 817376T01</b>	CABLE: BOBINA-DISTRIBUIDOR	WIRE LEAD: COIL HARNESS-DISTRIBUTOR	CAVO: BOBINA-DISTRIBUTORE	1
12	3854001	811639T	<b>REC3854001</b>	MÓDULO IMPULSOS	MODULE	MODULO	1

262 CID, V6, 4.3L



Nº	R.O. / OEM VOLVO	R.O. / OEM MERCURISER	Ref.	Descripción	Description	Descrizione	Cantidad Quantity Quantità
1	3853960	39-17464	REC11001	KIT AROS PISTÓN: 262 (alto 81 mm)	RING SET: 262 (height 81 mm)	KIT ANELLI: 262 (Alt. 81 mm)	6
1	21179959	39-801861 1	REC11004	KIT AROS PISTÓN: V6 (1996+ STD)	RING SET: V6 (1996+ STD)	KIT ANELLI: V6 (1996+ STD)	6
1			REC11016	KIT AROS PISTÓN: V6 (1996+ 0.30)	RING SET: V6 (1996+ 0.30)	KIT ANELLI: V6 (1996+ 0.30)	6
1	3853960	39-17464	REC11005	KIT AROS PISTÓN: PISTÓN 262/350 (-1995 STD)	RING SET: PISTON 262/350 (-1995 STD)	KIT ANELLI: PISTONE 262/350 (-1995 STD)	6
1	3853961	39-17465	REC11006	KIT AROS: PISTÓN 262 (-1995 0.30)	RING SET: PISTON 262 (-1995 0.30)	KIT ANELLI: PISTONE 262 (-1995 0.30)	6
1			REC11011	KIT AROS PISTÓN 262/350 (0.40) 71 mm	RING SET PISTON 262/350 (0.40) 71 mm	KIT ANELLI PISTONE 262/350 (0.40) 71 mm	6
2	3854219	735-850097	REC10004	PISTÓN: 262/350 (-1995 STD)	PISTON: 262/350 (-1995 STD)	PISTONE 262/350 (-1995 STD)	6
2			REC10018	PISTÓN 262/350 (-1995 0.40)	PISTON 262/350 (-1995 0.40)	PISTONE 262/350 (-1995 0.40)	6
2	3854221	735-850098	REC10005	PISTÓN: 262 (-1995 0.30)	PISTON: 262 (-1995 0.30)	PISTONE 262 (-1995 0.30)	6
2	21179952	735-835001T	REC10006	PISTÓN: V6 (1996+ STD)	PISTON: V6 (1996+ STD)	PISTONE V6 (1996+ STD)	6
2			REC10013	PISTÓN: V6 (1996+ 0.30)	PISTON: V6 (1996+ 0.30)	PISTONE V6 (1996+ 0.30)	6
3	21179974	614-811839T02	MP0009-036	BIELA: 262	CONNECTING ROD: 262	BIELLA: 262	6
4	21179992	23-11992001	REC13010	COJINETE BIELA 262	BEARING: CONNECTING ROD 262	CUSCINETTO: BIELLA 262	6
4		23-811858001	REC13011	COJINETE BIELA 262, 0.10 (0.25 mm)	BEARING: CONNECTING ROD 262, 0.10 (0.25 mm)	CUSCINETTO: BIELLA 262 0.10 (0.25 mm)	6
6	3854315	31-824150		COJINETE: EJE TRASERO	BEARING: BALANCE SHAFT REAR	CUSCINETTO: EQUILIBRIO DELL'ASSE POSTERIORE	1
7	3853209	22-72640	MP0009-208	KIT TAPÓN LATÓN DE EXPANSIÓN	BRASS EXPANSION PLUG KIT	KIT TAPPO ESPANSIONE IN OTTONE	1
8	3852657	26-8M0077606	REC26-14240	RETÉN ACEITE: CIGÜEÑAL RR PRE-VORTEC	SEAL: CRANKSHAFT RR OIL PRE-VORTEC	PARAOLIO: ALBERO A GOMITO RR PRE-VORTEC	1
8	3858698	26-879194364	RM26-879194364	RETÉN ACEITE: CIGÜEÑAL RR VORTEC Y MPI	SEAL: CRANKSHAFT RR OIL VORTEC & MPI	PARAOLIO: ALBERO A GOMITO RR VORTEC E MPI	1
9	3852656	27-14241	REC27-14241	JUNTA RETÉN ACEITE: CIGÜEÑAL RR HSG	GASKET: CRANKSHAFT RR OIL SEAL HSG	GUARNIZIONE: PARAOLIO: ALBERO A GOMITO RR HSG	1
10	3853341	26-97335	REC3853341	RETÉN ACEITE: CIGÜEÑAL FRONTAL PRE-VORTEC	SEAL: CRANKSHAFT FRONT OIL PRE-VORTEC	PARAOLIO: ALBERO A GOMITO FRONTALE PRE-VORTEC	1
12	3852654	27-14250	REC27-14250	JUNTA: TAPA DISTRIBUCIÓN	GASKET: ENGINE FRONT COVER	GUARNIZIONE COPERCHIO FRONTALE	1
13	3853215	23-818465	REC13012	KIT COJINETE CIGÜEÑAL STD	BEARING KIT: CRANKSHAFT STD	KIT CUSCINETTO: ALBERO MOTORE STD	1
13	856342	23-818467	REC13013	KIT COJINETE CIGÜEÑAL 0.10 (0.25 mm)	BEARING KIT: CRANKSHAFT 0.10 (0.25 mm)	KIT CUSCINETTO: ALBERO MOTORE 0.10 (0.25 mm)	1
14	3853194	14249A2	REC15251	TAPA: DISTRIBUIDOR 262 (-1995)	COVER: TIMING 262 (-1995)	COPERCHIO: DISTRIBUZIONE 262 (-1995)	1
14	3855735	809893	REC15252	TAPA: DISTRIBUIDOR 4.3V (1997+) (Sin sensor) Plástico	COVER: TIMING 4.3v (1997+) (Without Sensor) Plastic	COPERCHIO: DISTRIBUZIONE 4.3V (1997+) (senza sensore) Plastica	1
14	3859023	8M0069799	REC15253	TAPA: DISTRIBUIDOR 4.3V (1997+) (con sensor) Plástico	COVER: TIMING 4.3v (1997+) (With Sensor) Plastic	COPERCHIO: DISTRIBUZIONE 4.3V (1997+) (con sensore) Plastica	1
15	3857474	809892T	MP0009-004LC	AMORTIGUADOR: TORSIONAL 262	DAMPER: TORSIONAL 262	AMMORTIZZATORE: TORSIONAL 262	1
15	3859022	888776T	REC888776T	AMORTIGUADOR: TORSIONAL 262 (2002+) MPI	DAMPER: TORSIONAL 262 (2002+) MPI	AMMORTIZZATORE: TORSIONAL 262 (2002+) MPI	1
16	3856133	10-35366	REC859021	KIT TORNILLOS: TAPA DISTRIBUCIÓN	KIT BOLTS: TIMING COVER	KIT VITE: COPERCHIO DISTRIBUZIONE	1
17		11985	REC12502	CADENA: DISTRIBUIDOR 262 (-1986)	CHAIN: TIMING 262 (-1986)	CATENA: DISTRIBUZIONE 262 (-1986)	1
17	3852685	17161	REC12501	CADENA: DISTRIBUIDOR 262 (1987-98)	CHAIN: TIMING 262 (1987-98)	CATENA: DISTRIBUZIONE 262 (1987-96)	1
17	3859021	883494	RM883494	CADENA: DISTRIBUIDOR 4.3L (1998+)	CHAIN: TIMING 4.3L (1998+)	CATENA: DISTRIBUZIONE 4.3L (1998+)	1
18		431-9691	REC10252	ÁRBOL DE LEVAS: 262 Con lifter de rodillos PRE-VORTEC	CAMSHAFT: 262 With lifter Cam PRE-VORTEC	ALBERO A CAMME: 262 Con lifter de rulli PRE-VORTEC	1
19		23-85674	REC13014	KIT COJINETE: ÁRBOL LEVAS	BEARING KIT: CAMSHAFT	KIT CUSCINETTO: ALBERO A CAMME	1
20			REC157-N	CORONA DENTADA (157 dientes Ø12")	GEAR RING (157 Teeth Ø12")	CORONA DENTATA (157 denti Ø12")	1
20	3853143		REC1685	CORONA DENTADA (168 dientes Ø13-3/4")	GEAR RING (168 Teeth Ø13-3/4")	CORONA DENTATA (168 denti Ø13-3/4")	1
20			FED416-124	CORONA DENTADA (180 dientes Ø14-1/2")	GEAR RING (180 Teeth Ø14-1/2")	CORONA DENTATA (180 denti Ø14-1/2")	1
21			FEL17210	KIT JUNTAS (excepto motores eje equilibrado)	GASKET SET (except balanced shaft)	KIT GUARNIZIONE (Eccetto motori asse equilibrato)	1
21			FEL17211	KIT JUNTAS (Motores eje equilibrado)	GASKET SET (Balanced shaft engines)	KIT GUARNIZIONE (Motori asse equilibrato)	1
22	855283		MP514516	POLEA DE LA BOMBA DE DOBLE RANURA Ø150 mm	DUAL GROOVE PUMP PULLEY Ø150 mm	PULEGGIA POMPA DOPPIA SCANALATURA Ø150mm	1
23	835407	807730	MP514693	POLEA CIGÜEÑAL DOBLE RANURA Ø 173 mm	DUAL GROOVE CRANK PULLEY Ø 173 mm	PULEGGIA ALBERO MOTORE, DOPPIA SCANALATURA Ø 173 mm	1
24	3860201	807757T	REC807757T	POLEA SERPENTINA MCM (Plástico) 3" OD	SERPENTINE PULLEY MCM (Plastic) 3" OD	PULEGGIA A SERPENTINA MCM (plastica) 3" OD	1
25	3853195	75435A1	MP0011-045	INDICADOR DE DISTRIBUCIÓN	INDICATOR TIMING	INDICATORE DISTRIBUZIONE	1
26	21114522		REC38201	RACORD DRENAJE COMPLETO	FULL FEETING	RACCORDO COMPLETO	1
27				ACOPLAMIENTO	DAMPER	ACCOPIAMENTO	1
28	865598	8M6500024	REC8M6500024	POLEA	PULLEY	PULEGGIA	1



262 CID, V6, 4.3L

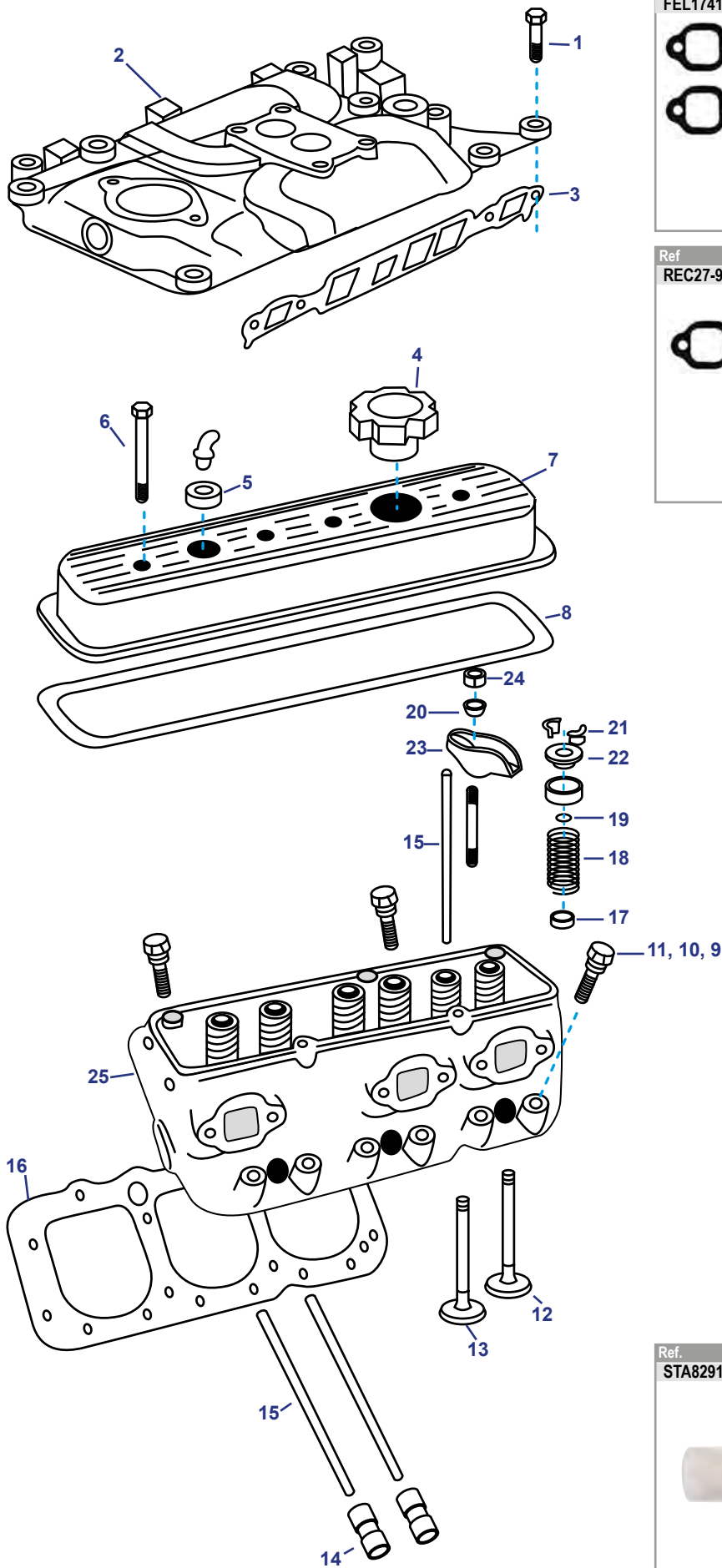

Ref.  
FEL17410

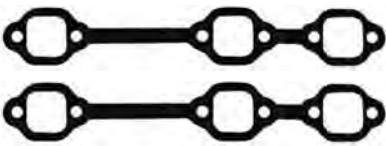

Kit juntas colector  
Gasket set manifold  
Kit guarnizione collettore

Ref.  
REC27-99757



Junta coelctor  
Gasket manifold  
Guarnizione collettore

Ref.  
STA82910



Silicona para juntas  
Liquid gasket  
Silicone guarnizione

PAG 11

Nº	R.O. / OEM VOLVO	R.O. / OEM MERCUISER	Ref.	Descripción	Description	Descrizione	Cantidad Quantity Quantità
1	3856765	10-835004	MP001204	TORNILLO: COLECTOR ADMISIÓN	BOLT: INTAKE MANIFOLD	VITE: COLLETTORE ASPIRAZIONE	8
2	3855806	824330T1	MP425036	COLECTOR ADMISIÓN VORTEC 4BBL	INTAKE MANIFOLD VORTEC 4BBL	COLLETTORE ASPIRAZIONE VORTEC 4BBL	1
2	3855805	824324T	MP425024	COLECTOR ADMISIÓN VORTEC 2BBL	INTAKE MANIFOLD VORTEC 2BBL	COLLETTORE ASPIRAZIONE VORTEC 2BBL	1
3	857177	27-11977	FEL17310	JUNTA: COLECTOR ADMISIÓN	GASKET: INTAKE MANIFOLD	GUARNIZIONE: COLLETTORE ASPIRAZIONE	2
3	3855807	27-824326002	REC824326002	JUNTA: COLECTOR ADMISIÓN VORTEC	GASKET: INTAKE MANIFOLD VORTEC	GUARNIZIONE: COLLETTORE ASPIRAZIONE VORTEC	2
4	3854008	36-18710002	REC6532	TAPÓN ACEITE	CAP OIL FILL	TAPPO OLIO	2
5	835415	8M0071559	RECTW9760	ANILLO: TAPA VÁLVULA	GROMMET: VALVE COVER	ANELLO: COPERCHIO VALVOLA	2
6	3856135	10-17344	MP0009-107	TORNILLO: TAPA VÁLVULA	BOLT: VALVE COVER	VITE: COPERCHIO VALVOLA	6
7	3854948	827150	MP0009-194LC	TAPA VÁLVULA: VORTEC (Con tapón)	VALVE COVER VORTEC (With Seal)	COPERCHIO VALVOLA: VORTEC (Con cappuccio)	1
7	3854949	827149	MP0009-195LC	TAPA VÁLVULA: VORTEC (Sin tapón)	VALVE COVER VORTEC (Without Seal)	COPERCHIO VALVOLA: VORTEC (Senza cappuccio)	1
7	3854945	14251	RECTW6502T	TAPA VÁLVULA: PREVORTEC (Con tapón)	VALVE COVER PREVORTEC (With Seal)	COPERCHIO VALVOLA: PREVORTEC (Con cappuccio)	1
7	3854945	14252	RECTW6502	TAPA VÁLVULA: PREVORTEC (Sin tapón)	VALVE COVER PREVORTEC (Without Seal)	COPERCHIO VALVOLA: PREVORTEC (Senza cappuccio)	1
8	3854300	27-11988	FEL17920	KIT JUNTAS: TAPA VÁLVULA PREVORTEC	GASKET KIT: VALVE COVER PRE VORTEC	KIT GUARNIZIONE: COPERCHIO VALVOLA PREVORTEC	2
8	3854942	27-827154	FEL17921	KIT JUNTAS: TAPA VÁLVULA VORTEC	GASKET KIT: VALVE COVER VORTEC	KIT GUARNIZIONE: COPERCHIO VALVOLA VORTEC	2
9	3856122	10-11966	MP0007-027	TORNILLO LARGO: CULATA (,437-14x1.750)	BOLT: CYLINDER HEAD LONG (,437-14x1.750)	VITE LUNGO: TESTATA (,437-14x1.750)	10
10	3856123	10-11967	MP0007-028	TORNILLO MEDIANO: CULATA (,437-14x3.00)	BOLT: CYLINDER HEAD MEDIUM (,437-14x3.00)	VITE MEDIO: TESTATA (,437-14x3.00)	4
11	3856124	10-11968	MP0007-029	TORNILLO CORTO: CULATA	BOLT: CYLINDER HEAD SHORT	VITE CORTO: TESTATA	12
12	856368	85803	REC13502	VÁLVULA: ESCAPE 262 (38,2-8,8-125,2)	VALVE: EXHAUST 262 (38,2-8,8-125,2)	VALVOLA: SCARICO 262 (38,2-8,8-125,2)	6
12	3855808	824317 1	REC13505	VÁLVULA: ESCAPE 262 VORTEC (1993+) (38-8,7-125)	VALVE: EXHAUST 262 VORTEC (1993+) (38-8,7-125)	VALVOLA: SCARICO 262 VORTEC (1993+) (38-8,7-125)	6
13	841873	97661	REC13506	VÁLVULA: ADMISIÓN 262 (49-8,8-124)	VALVE: INTAKE 262 (49-8,8-124)	VALVOLA: ASPIRAZIONE 262 (49-8,8-124)	6
13	3855810	809992	REC13507	VÁLVULA: ADMISIÓN 262 VORTEC (1993+) (49,2-8,7-124)	VALVE: INTAKE 262 VORTEC (1993+) (49,2-8,7-124)	VALVOLA: ASPIRAZIONE 262 VORTEC (1993+) (19,2-8,7-124)	6
14	3855811	811844T	RM811844T	EMPUJADOR: VÁLVULA 4.3 VORTEC (1996+)	LIFTER: VALVE 4.3 VORTEC (1996+)	ALZA VALVOLA 4.3 VORTEC (1996+)	12
14	856397	17340T	REC14001	EMPUJADOR: VÁLVULA 262 (1987+)	LIFTER: VALVE 262 (1987+)	ALZA VALVOLA 262 (1987+)	12
14	3853954	72638	REC14000	EMPUJADOR: VÁLVULA 262 (-1986)	LIFTER: VALVE 262 (-1986)	ALZA VALVOLA 262 (-1986)	12
15	3853157	99948	REC12000	VARILLA 262 (-1986)	ROD: PUSH 262 (-1986)	ASTA DI BIELLA 262 (-1986)	12
15	3853170	17739	REC12002	VARILLA 262 (1986+)	ROD: PUSH 262 (1986+)	ASTA DI BIELLA 262 (1986+)	12
16	3854299	27-879150140	FEL17010	JUNTA: CULATA	GASKET: CYLINDER HEAD	GUARNIZIONE: TESTATA	2
17	3853226	26-97664	REC70817B	RETÉN: VÁSTAGO VÁLVULA DE ADMISIÓN	SEAL: INTAKE VALVE STEM	GUARNIZIONE: ASTA VALVOLA ASPIRAZIONE	6
18	3853227	24-48347	REC11500	MUELLE: VÁLVULA 262/350	SPRING: VALVE 262/350	MOLLA: VALVOLA 262/350	12
19	3854956	26-34217	REC26-34217	RETÉN	SEAL	TENUTA	12
20	3853198	59340	RM59340	ROTOR: VÁLVULA	ROTATOR: VALVE	ROTORE: VALVOLA	6
21	3855823	28-54797 1		CHAVETA: VÁSTAGO VÁLVULA	KEY: VALVE STEM	CHIAVETTA: ASTA VALVOLA	12
22	3853229	48348	MP0007-378	TAPÓN: MUELLE VÁLVULA	CAP: VALVE SPRING	TAPPO: MOLLA VALVOLA	6
23	3853158	35329	REC10352	BRAZO BALANCÍN	ARM: ROCKER	BILANCERE	12
24	3853004	11-34516	MP0007-122	TUERCA: BRAZO BALANCÍN	NUT: ROCKER ARM	DADO: BILANCERE	12
25				CULATA	CYLINDER HEAD	TESTATA	2

262 CID, V6, 4.3L

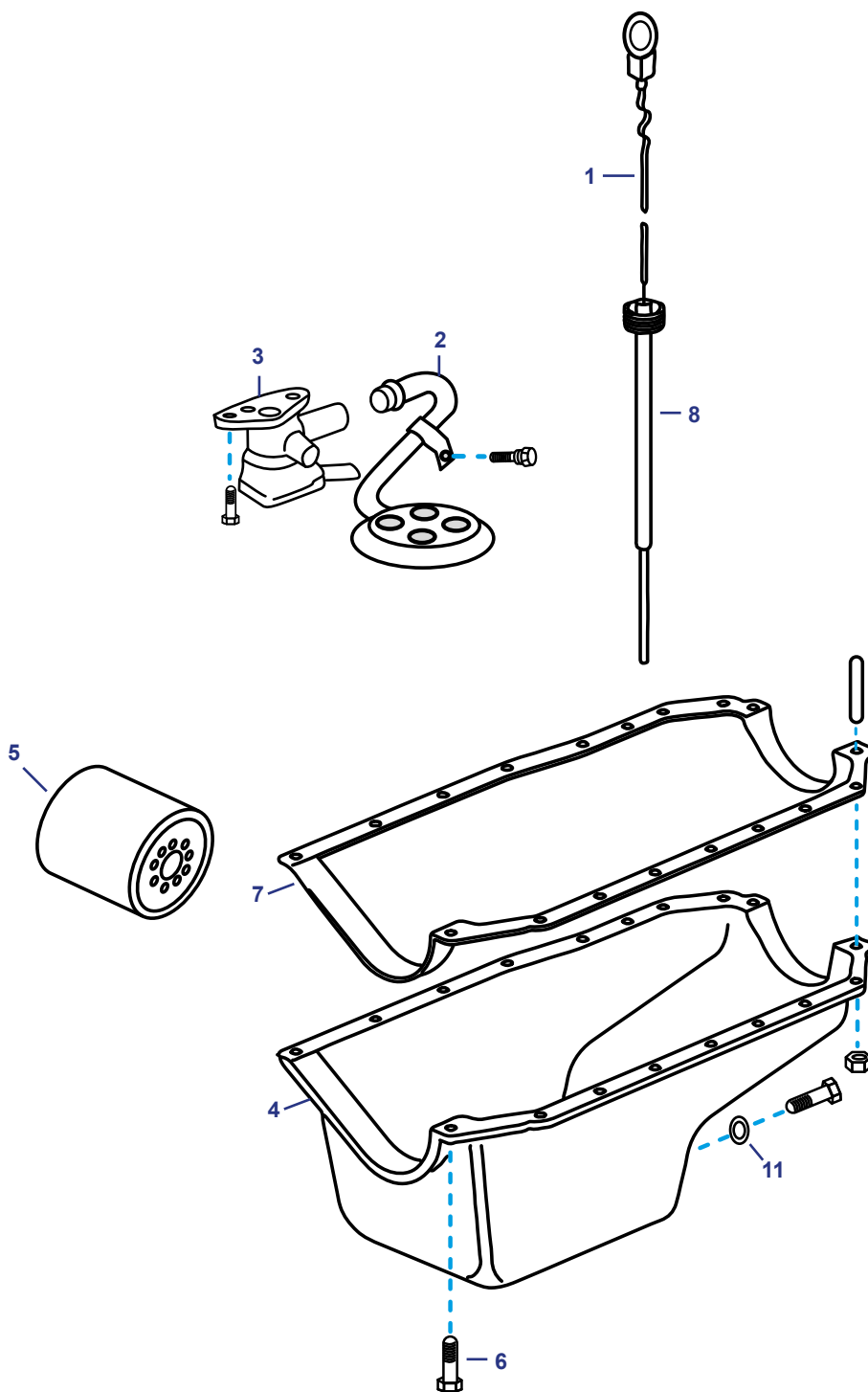

Nº 9

Kit juntas colector  
Gasket set manifold  
Kit guarnizione collettore



Nº 10

Tubo drenaje  
Drain hose tube  
Tubo di scarico

Ref. STA82910

Silicona para juntas  
Liquid gasket  
Silicone guarnizione

PAG 11

Nº	R.O. / OEM VOLVO	R.O. / OEM MERCUISER	Ref.	Descripción	Description	Descrizione	Cantidad Quanty Quantità
1		861942 17	REC551455	VARILLA ACEITE 262/350	DIPSTICK 262/350	ASTA DI LIVELLO 262/350	1
2	3853197	809908 1	MP0007-256	TUBO Y FILTRO: BOMBA ACEITE	TUBE & SCREEN: OIL PUMP	TUBO E FILTRO: POMPA OLIO	1
3	3853851	17617	REC14101	BOMBA ACEITE: PREVORTEC	PUMP: OIL PRE VORTEC	POMPA OLIO: PRE VORTEC	1
3	3856125	809907002	RM809907002	BOMBA ACEITE: VORTEC	PUMP: OIL VORTEC	POMPA OLIO: VORTEC	1
4	856386	14244T	REC15351	CÁRTER: 262	OIL PAN: 262	COPPA OLIO: 262	1
4	21124851	809980T1	RM809980T1	CÁRTER ALUMINIO BLOQUE GM 8LK, 8LJ VORTEC	OIL PAN ALUMINUM GM BLOCK: 8LK, 8LJ VORTEC	COPPA OLIO ALLUMINIO BLOCCO GM 8LK, 8LJ VORTEC	1
4	21124851	804912T01	RM804912T01	CÁRTER ALUMINIO BLOQUE GM 9LK, 9LJ, 0LJ	OIL PAN ALUMINUM GM BLOCK: 9LK, 9LJ, 0LJ	COPPA OLIO ALLUMINIO BLOCCO GM 9LK, 9LJ, 0LJ	1
5				FILTRO ACEITE 262	FILTER: OIL 262	FILTRO OLIO: 262	1
6	940135	14070	RECPNRS-1100	KIT TORNILLO CÁRTER	BOLT SET: OIL PAN	KIT VITE: COPPA OLIO	1
7	855729	27-42797	FEL17970	JUNTA: CÁRTER (4 Piezas)	GASKET: OIL PAN (4 PCS.)	GUARNIZIONE: COPPA OLIO (4 pezzi)	1
7	3852655	27-883964T	FEL17971	JUNTA: CÁRTER (1 Pieza)	GASKET: OIL PAN (1 PC.)	GUARNIZIONE: COPPA OLIO (1 pezzo)	1
7	21124852	27-142471	RM27-142471	JUNTA: CÁRTER 262 VORTEC 1 PIEZA	GASKET: OIL PAN 262 VORTEC 1 PC.	GUARNIZIONE: COPPA OLIO 262 VORTEC (1 pezzo)	1
8	856248	12117A5	MP0307-002	VARILLA TUBO: 262 (BLOQUE)	DIPSTICK TUBE: 262 (BLOCK)	ASTA DI LIVELLO TUBO: 262 (BLOCCO)	1
8	3860214	860209A1	MP0009-002N5	VARILLA TUBO: 4.3V (1999+) (CÁRTER)	DIPSTICK TUBE: 4.3V (1999+) (OIL PAN)	ASTA DI LIVELLO TUBO: 4.3V (1999+) (COPPA OLIO)	1
9			FEL17110	KIT JUNTAS (4 juntas cárter + 2 juntas retén trasero)	GASKET SET (4 Oil pan gaskets & 2 pcs rear seal)	KIT GUARNIZIONE (4 guarnizione coppa olio + 2 guarnizione tenuta posteriore)	1
9			FEL17115	KIT JUNTAS (1 junta cárter, retén trasero 1 pieza, excepto eje equilibrado)	GASKET SET (1 Oil pan gasket & 1 pcs rear seal, excluded balanced shaft)	KIT GUARNIZIONE (1 guarn. coppa olio + 1 tenuta posteriore, escluso albero bilanciato)	1
9			FEL17116	KIT JUNTAS (1 junta cárter, retén trasero 1 pieza, con eje equilibrado)	GASKET SET (1 Oil pan gasket & 1 pcs rear seal, with balanced shaft)	KIT GUARNIZIONE (1 guarn. coppa olio + 1 tenuta posteriore, con albero bilanciato)	1
10			MPI305-0380	MANGUERA DE VACIADO MCM-OMC 1/2"	DRAIN HOSE MCM-OMC 1/2"	TUBO DI SCARICO MCM-OMC 1/2"	1
10			MPI307-0380	MANGUERA DE VACIADO VOLVO 3/4"	DRAIN HOSE VOLVO 3/4"	TUBO DI SCARICO VOLVO 3/4"	1
10			MPI309-0380	MANGUERA DE VACIADO FORD 14 mm	DRAIN HOSE FORD 14mm	TUBO DI SCARICO FORD 14mm	1
11	3851981	27-49955	REC27-49955	JUNTA	GASKET	GUARNIZIONE	1

**262 CID, V6, 4.3L**

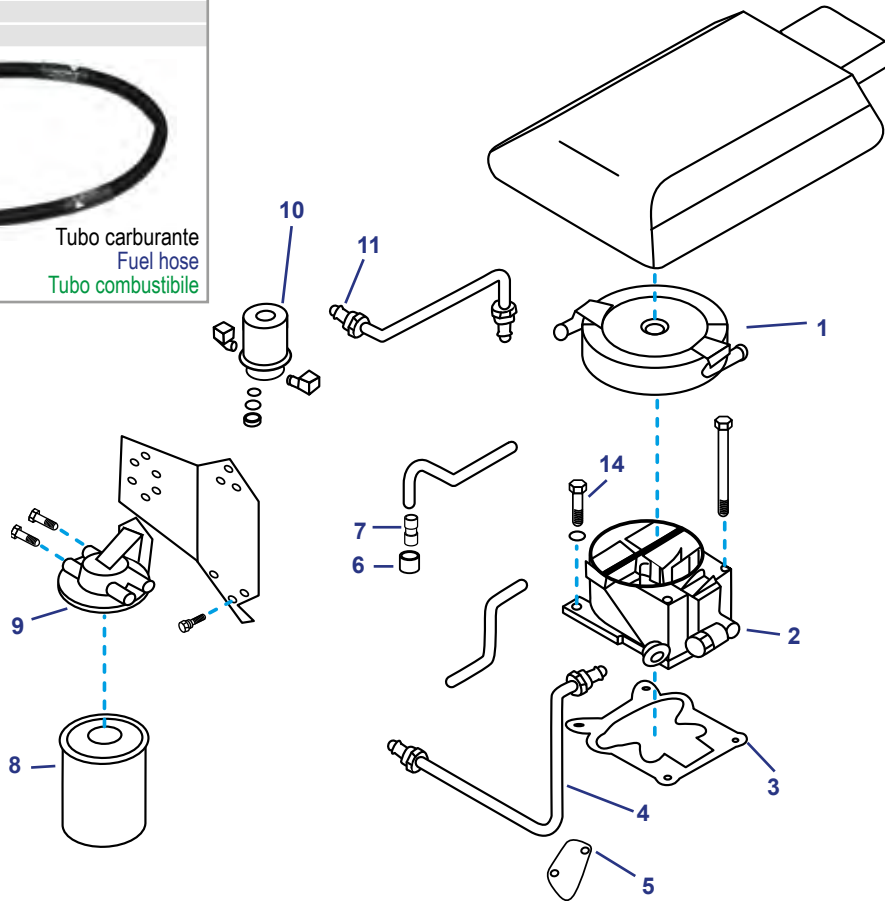
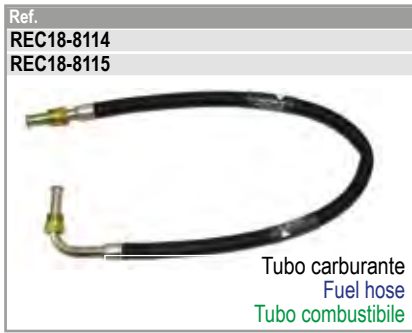

Nº	R.O. / OEM VOLVO	R.O. / OEM MERCURUISER	Ref.	Descripción	Description	Descrizione	Cantidad Quantity
1	3854026	805016A1	REC805298A1	PARALLAMAS 262/350 STD	FLAME ARRESTOR 262/350 STD	ANTIFIAMMA 262/350 STD	1
2				CARBURADOR	CARBURETOR	CARBURATORE	1
2	3854346		MP426422	NUEVO CARBURADOR 262 HOLLEY 2 BBL	NEW CARBURETOR 262 HOLLEY 2 BBL	NUOVO CARBURATORE 262 HOLLEY 2 BBL	1
2	3850288		MP426434	NUEVO CARBURADOR 262 HOLLEY 4 BBL	NEW CARBURETOR 262 HOLLEY 4 BBL	NUOVO CARBURATORE 262 HOLLEY 4 BBL	1
3				JUNTA CARBURADOR	GASKET CARBURETOR	GUARNIZIONE CARBURATORE	1
4			MP429905	TUBO BOMBA COMBUSTIBLE A CARBURADOR	FUEL LINE FUEL PUMP TO CARBURETOR	TUBO POMPA CARBURANTE A CARBURATORE	1
5			MP0309-021	PLACA DE BLOQUEO MECÁNICO (BOMBA DE COMBUSTIBLE)	PLATE BLOCK-OFF (MECH FUEL PUMP)	PIASTRA DI CHIUSURA MECCANICA (POMPA CARBURANTE)	1
6			MP806200	ANILLO	VALVE COVER	ANELLO	2
7				CONECTOR	CONECTOR	CONNETTORE	2
8				FILTRO COMBUSTIBLE CON SEPARADOR DE AGUA	FUEL FILTER / WATER SEPARATOR	FILTRO CARBURANTE CON SEPARATORE D'ACQUA	1
9			REC25000	BRACKET	BRACKET	BRACKET	1
10				BOMBA COMBUSTIBLE	FUEL PUMPS	POMPA CARBURANTE	1
11			MP429415	TUBO BOMBA	FUEL LINE: SEP-PUMP PORT	TUBO POMPA	1

## 262 CID, V6, 4.3L

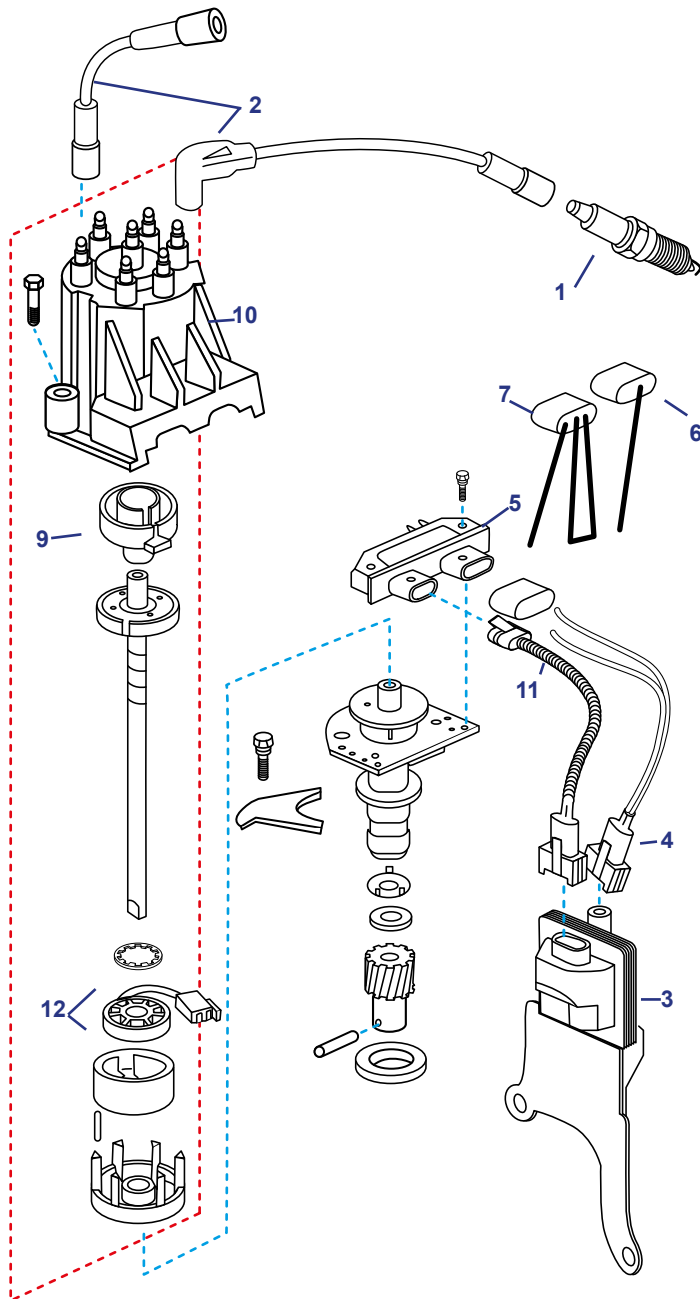

Para otros modelos consultar:  
For other models see:  
Per altri modelli vedi:



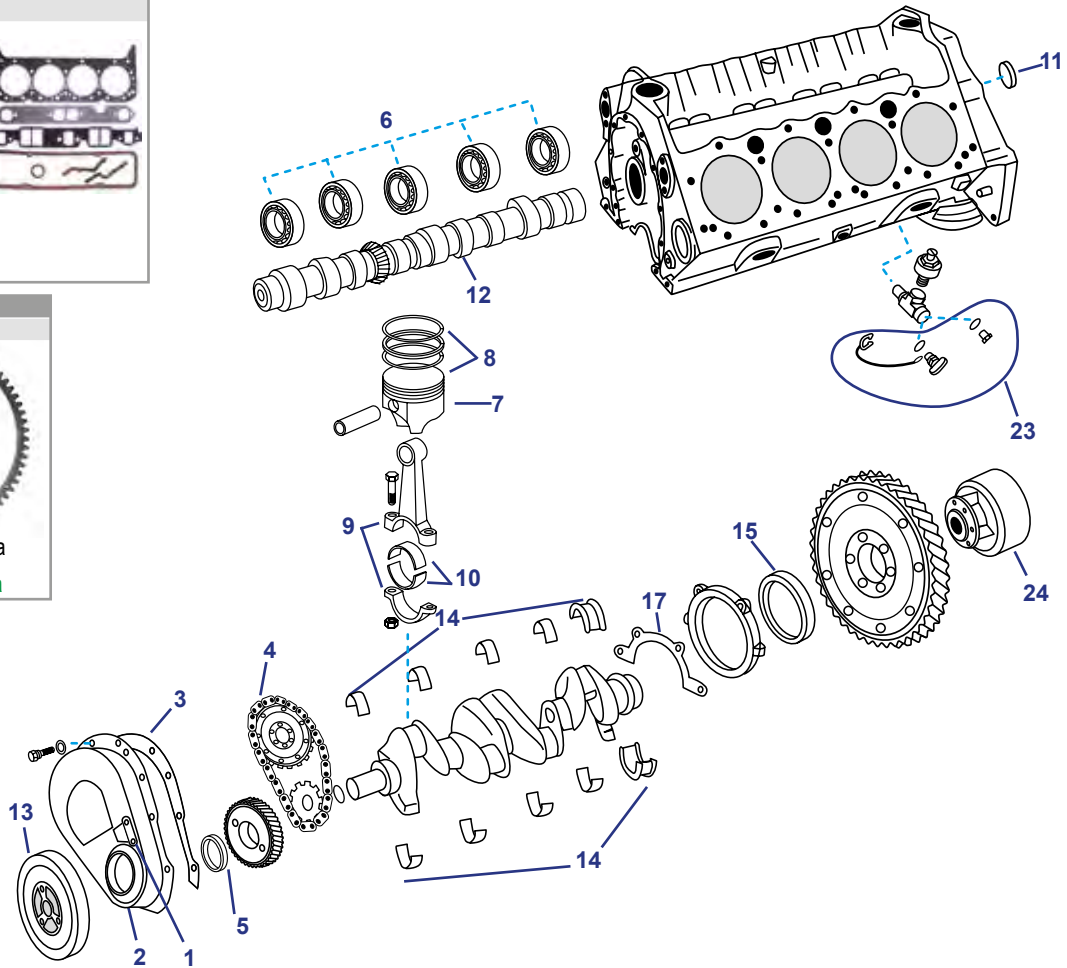
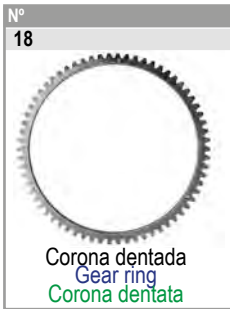

Nº	R.O. / OEM VOLVO	R.O. / OEM MERCURUISER	Ref.	Descripción	Description	Descrizione	Cantidad Quantity Quantità
1				BUJÍAS	SPARK PLUGS	CANDELE	6
2				CABLE ARRANQUE: SET V6	IGNITION WIRE: SET V6	CAVO INNIETIONE: SET V6	7
3	3854084	84-817386T01	REC3854002	BOBINA: DELCO	COIL: DELCO E.I.	BOBINA: DELCO	1
4	3854002	811637001	REC500442	CABLE: BOBINA	WIRE LEAD: COIL	CAVO: BOBINA	1
5	3854003	91-888863	REC3854003	MÓDULO: DELCO DISTRIBUIDOR	MODULE: DELCO DIST	MODULO: DELCO DISTRIBUZIONE	1
6			REC294005	CABLE IGNICIÓN: INTERRUPTOR	IGNITION WIRE: SHIFT INTERRUPTER	CAVO ACCENSIONE: INTERRUPTORE	1
7			REC91-888863	HERRAMIENTA	TOOL: TIMING	STRUMENTO	1
8		807964A1	REC807964A1	DISTRIBUIDOR: 262 (5, 9 y 10 incluidos)	DISTRIBUTOR: 262 (5, 9 & 10 Included)	DISTRIBUZIONE: 262 (5, 9 e 10 Compresi)	1
9	3854311	8M0062084	REC3854311	ROTOR: V6 DIST	ROTOR: V6 DIST	ROTORE: V6 DIST	1
10	3854331	850484T2	REC3854331	TAPA: V6 DIST	CAP: V6 DIST	COPERCHIO: V6 DIST	1
11	3854084	84-817376T01	REC84-817376T01	CABLES DE LA BOBINA A DISTRIBUIDOR	WIRE LEAD: COIL HARNESS TO DISTRIBUTOR	CAVI BOBINA A DISTRIBUZIONE	1
12	3854001	811639T	REC3854001	MÓDULO	MODUL	MODULO	1

**V8 BLOQUE PEQUEÑO / SMALL BLOCK / BLOCCO PICCOLO 5.0 & 5.7L**



Nº	R.O. / OEM VOLVO	R.O. / OEM MERCURUISER	Ref.	Descripción	Description	Descrizione	Cantidad Quantity Quantità
1	3853195	75435A1	<b>MP0011-045</b>	INDICADOR DE DISTRIBUCIÓN	INDICATOR TIMING	INDICATORE DISTRIBUZIONE	1
2	3853194	14249A2	<b>REC15251</b>	TAPA DISTRIBUIDOR SB NR (metálica)	COVER TIMING SB NR (metal)	COPERCHIO DISTRIBUZIONE SB NR (metallo)	1
2		835005	<b>MP804007</b>	TAPA DISTRIBUIDOR (Plástico) (1996+) sin sensor	COVER TIMING (Plastic) (1996+) W/O Sensor	COPERCHIO DISTRIB. (Plastica) (1996+) senza sensore	1
2	3862263	863396	<b>REC15254</b>	TAPA DISTRIBUIDOR (Plástico) (1996+) con sensor	COVER TIMING (Plastic) (1996+) With Sensor	COPERCHIO DISTRIB. (Plastica) (1996+) con sensore	1
3	3852654	27-14250	<b>REC27-14250</b>	JUNTA TAPA DISTRIBUIDOR	GASKET TIMING COVER	GUARNIZIONE COPERCHIO DISTRIBUZIONE	1
4	835405	35378	<b>REC12503</b>	CADENA DISTRIBUIDOR 305, 350 (-1987)	CHAIN TIMING 305, 350 (-1987)	CATENA DISTRIBUZIONE 305, 350 (-1987)	1
4	3852685	17161T	<b>MP0017-082</b>	CADENA DISTRIBUIDOR (1987+)	CHAIN TIMING (1987+)	CATENA DISTRIBUZIONE (1987+)	1
5	3853341	26-97335	<b>REC3853341</b>	RETÉN CIGÜEÑAL SB NR y OR	SEAL FRONT SB NR & OR	TENUTA FRONTALE SB NR e OR	1
6	3856162	23-85674	<b>REC13014</b>	COJINETE ÁRBOL DE LEVAS	BEARING CAMSHAFT	CUSCINETTO ALBERO A CAMME	2
7	3857667	735-802557T	<b>RM735-802557T</b>	PISTÓN 5.0L STD (1998+)	PISTON 5.0L STD (1998+)	PISTONE 5.0L STD (1998+)	8
7	856061	735-9716T1		PISTÓN 5.0L STD (1987-97)	PISTON 5.0L STD (1987-97)	PISTONE 5.0L STD (1987-97)	8
7			<b>REC10015</b>	PISTÓN 5.0L 0.20 (1987-97)	PISTON 5.0L 0.20 (1987-97)	PISTONE 5.0L 0.20 (1987-97)	8
7	856063	735-9715T1	<b>REC10008</b>	PISTÓN 5.0L 0.30 (1987-97)	PISTON 5.0L 0.30 (1987-97)	PISTONE 5.0L 0.30 (1987-97)	8
7	826465	735-6370	<b>REC10009</b>	PISTÓN 5.0L (-1987)	PISTON 5.0L (-1987)	PISTONE 5.0L (-1987)	8
7		735-6371	<b>REC10010</b>	PISTÓN 5.0L 0.30 (-1987)	PISTON 5.0L 0.30 (-1987)	PISTONE 5.0L 0.30 (-1987)	8
7	21179952	735-850097	<b>REC10006</b>	PISTÓN 5.7L (1996+)	PISTON 5.7L (1996+)	PISTONE 5.7L (1996+)	8

Nº	R.O. / OEM VOLVO	R.O. / OEM MERCURISER	Ref.	Descripción	Description	Descrizione	Cantidad Quantity Quantità
7		735-850098	REC10013	PISTÓN 5.7L 0.30 (1996+)	PISTON 5.7L 0.30 (1996+)	PISTONE 5.7L 0.30 (1996+)	8
7	3854219	735-9716T1	REC10004	PISTÓN 5.7L STD (-1995)	PISTON 5.7L STD (-1995)	PISTONE 5.7L STD (-1995)	8
7	3854221	735-9715T1	REC10005	PISTÓN 5.7L 0.30 (-1995)	PISTON 5.7L 0.30 (-1995)	PISTONE 5.7L 0.30 (-1995)	8
7			REC10018	PISTÓN 262/350 (-1995 0.40)	PISTON 262/350 (-1995 0.40)	PISTONE 262/350 (-1995 0.40)	8
8	3857670	39-802559	RM39-802559	KIT AROS 5.0L STD 1998+	RING SET 5.0L STD 1998+	KIT ANELLI 5.0L STD 1998+	8
8		39-75609	REC11009	KIT AROS 5.0L STD (1976-97)	RING SET 5.0L STD (1976-97)	KIT ANELLI 5.0L STD (1976-97)	8
8			REC11020	KIT AROS 5.0L 0.20 (1976-97)	RING SET 5.0L 0.20 (1976-97)	KIT ANELLI 5.0L 0.20 (1976-97)	8
8	826470	39-75981	REC11010	KIT AROS 5.0L 0.30 (1976-97)	RING SET 5.0L 0.30 (1976-97)	KIT ANELLI 5.0L 0.30 (1976-97)	8
8	21179959	39-801861	REC11004	KIT AROS 5.7L STD (1996+)	RING SET 5.7L STD (1996+)	KIT ANELLI 5.7L STD (1996+)	8
8		39-17465	REC11016	KIT AROS 5.7L STD 0.30 (1996+)	RING SET 5.7L STD 0.30 (1996+)	KIT ANELLI 5.7L STD 0.30 (1996+)	8
8	857240	39-801861	REC11005	KIT AROS 5.7L STD 71mm	RING SET 5.7L STD 71mm	KIT ANELLI 5.7L STD 71mm	8
8	3853961	39-17465	REC11006	KIT AROS 5.7L 0.30 71 mm	RING SET 5.7L 0.30 71mm	KIT ANELLI 5.7L 0.30 71 mm	8
8			REC11011	KIT AROS 5.7L 0.40 71 mm	RING SET 5.7L 0.40 71mm	KIT ANELLI 5.7L 0.40 71 mm	8
8	3853960	39-17464	REC11001	KIT AROS 5.7L STD 81 mm	RING SET 5.7L STD 81mm	KIT ANELLI 5.7L STD 81 mm	8
10	3853149	23-85701	REC13001	KIT COJINETES: BIELA 5.0 y 5.7	BEARING KIT: CONN ROD 5.0 & 5.7	KIT CUSCINETTO: BIELLA 5.0 y 5.7	1
10	3856117	23-85704	REC13002	KIT COJINETES: BIELA 0.10 5.0 y 5.7 (0.25 mm)	BEARING KIT: CONN ROD 0.10 5.0 & 5.7 (0.25 mm)	KIT CUSCINETTO: BIELLA 0.10 5.0 y 5.7 (0.25 mm)	1
10	3853153	23-85705	REC13024	KIT COJINETES: BIELA 0.20 5.0 y 5.7 (0.51 mm)	BEARING KIT: CONN ROD 0.20 5.0 & 5.7 (0.51 mm)	KIT CUSCINETTO: BIELLA 0.20 5.0 y 5.7 (0.51 mm)	1
11	3853209	22-72640	MP0009-208	TAPÓN DE EXPANSIÓN KIT DE LATÓN	BRASS EXPANSION PLUG KIT	TAPPO A ESPANSIONE KIT IN OTTONE	1
12	3853159	431-811658	REC10253	ÁRBOL DE LEVAS: 350 NR & 305	CAMSHAFT: 350 NR & 305	ALBERO MOTORE: 350 NR & 305	1
13	3854023	852946001	MP0009-004LC	AMORTIGUADOR: TORSIONAL 5.0L & 4.3	DAMPER: TORSIONAL 5.0L & 4.3	AMMORTIZZATORE: TORSIONALE 5.0L & 4.3	1
13			MP0007-004	AMORTIGUADOR: TORSIONAL 350 & CA	DAMPER: TORSIONAL 350 & CA	AMMORTIZZATORE: TORNISONALE 350 & CA	1
14		23-85698	REC13012	KIT COJINETE: CIGÜEÑAL NR	BEARING KIT: CRANKSHAFT NR	KIT CUSCINETTO: ALBERO MOTORE NR	1
14	3862360	23-818465	REC13015	KIT COJINETE: CIGÜEÑAL NR (1996+)	BEARING KIT: CRANKSHAFT NR (1996+)	KIT CUSCINETTO: ALBERO MOTORE NR (1996+)	1
14		23-818467	REC13013	KIT COJINETE: CIGÜEÑAL NR 0.10 (0.25 mm)	BEARING KIT: CRANKSHAFT NR 0.10 (0.25 mm)	KIT CUSCINETTO: ALBERO MOTORE NR 0.10 (0.25 mm)	1
14		23-818468	REC13025	KIT COJINTE: CIGÜEÑAL NR 0.20 (0.51 mm)	BEARING KIT: CRANKSHAFT NR 0.20 (0.51 mm)	KIT CUSCINETTO: ALBERO MOTORE NR 0.20 (0.51 mm)	1
14		23-818467	REC13016	KIT COJINTE: CIGÜEÑAL NR 0.10 (1996+) (0.25 mm)	BEARING KIT: CRANKSHAFT NR 0.10 (1996+) (0.25 mm)	KIT CUSCINETTO: ALBERO MOTORE NR 0.10 (1996+) (0.25 mm)	1
15	3852657	26-14240	REC26-14240	RETÉN: CIGÜEÑAL RR SB (1996+)	SEAL: CRANKSHAFT RR SB (1996+)	PARAOLIO: ALBERO MOTORE RR SB (1996+)	1
15	841240	26-814622	FELBS40013	RETÉN: CIGÜEÑAL RR SB (2 piezas)	SEAL: CRANKSHAFT RR SB (2 pcs.)	PARAOLIO: ALBERO MOTORE RR SB (2 peci)	1
15		26-35313	FEL17725	RETÉN: CIGÜEÑAL OR (2 piezas)	SEAL: CRANKSHAFT OR (2 pcs.)	PARAOLIO: ALBERO MOTORE OR (2 peci)	1
15	3856926	26-15123	FEL17725	RETÉN: CIGÜEÑAL OR (1 pieza)	SEAL: CRANKSHAFT OR (1 pcs.)	PARAOLIO: ALBERO MOTORE OR (1 peza)	1
17	3852656	27-14241	REC27-14241	JUNTA: CIGÜEÑAL RR	GASKET: CRANKSHAFT RR	GUARNIZIONE: ALBERO MOTORE RR	1
18			REC157-N	CORONA DENTADA (157 dientes Ø12")	GEAR RING (157 Teeth Ø12")	CORONA DENTATA (157 denti Ø12")	1
18	3853143		REC1685	CORONA DENTADA (168 dientes Ø13 - 3/4")	GEAR RING (168 Teeth Ø13-3/4")	CORONA DENTATA (168 denti Ø13 - 3/4")	1
18			FED416-124	CORONA DENTADA (180 dientes Ø14-1/2")	GEAR RING (180 Teeth Ø14-1/2")	CORONA DENTATA 180 denti Ø14-1/2")	1
19			FEL17220	KIT JUNTAS 5.0L (agujeros en el perímetro)*	GASKET KIT 5.0L (Holes in perimeter)*	KIT GUARNIZIONE 5.0L (fori nel perimetro)*	1
19			FEL17224	KIT JUNTAS 5.0L (agujeros en el centro)*	GASKET KIT 5.0L (Holes in cente)*	KIT GUARNIZIONE 5.0L (fori in centro)*	1
19			FEL17230	KIT JUNTAS 5.7L (agujeros en el perímetro)*	GASKET KIT 5.7L (Holes in perimeter)*	KIT GUARNIZIONE 5.7L (fori nel perimetro)*	1
19			FEL17214	KIT JUNTAS 5.7L (agujeros en el centro)*	GASKET KIT 5.0L (Holes in center)*	KIT GUARNIZIONE 5.7L (fori al centro)*	1
19			FEL17232	KIT JUNTAS 5.7L GENE+ VORTEC	GASKET SET 5.7L GENE+ VORTEC	KIT GUARNIZIONE 5.7L GENE+ VORTEC	1
20	855283		MP514516	POLEA DE LA BOMBA DE DOBLE RANURA Ø150 mm	DUAL GROOVE PUMP PULLEY Ø150 mm.	PULEGGIA POMPA, DOPPIA SCALANATURA Ø150 mm	1
21	835407		MP514693	POLEA DEL CIGÜEÑAL DE DOBLE RANURA	DUAL GROOVE CRANK PULLEY	PULEGGIA ALBERO MOTORE DE DOPPIO SLOT	1
22			REC807757T	POLEA SERPENTINA 3" OD MCM (Plástico)	SERPENTINE PULLEY 3" OD MCM (Plastic)	PULEGGIA SERPENTINA 3" OD MCM (Plastica)	1
23	21114522		REC38201	RACORD DRENAJE COMPLETO	FULL FEETING	RACCORDO COMPLETO	1
24				ACOPLE	DUMPLER	ACCOPPIAMENTO	1
25	865598	8M6500024	REC8M6500024	POLEA	PULLEY	PULEGGIA	1

\* Agujeros en la tapa de balancín / Holes in rocker cover / Fori in copperchio di bilanciere



**V8 BLOQUE PEQUEÑO / SMALL BLOCK / BLOCCO PICCOLO 5.0 & 5.7L**

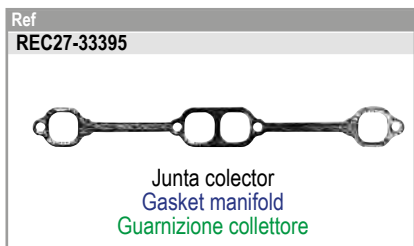
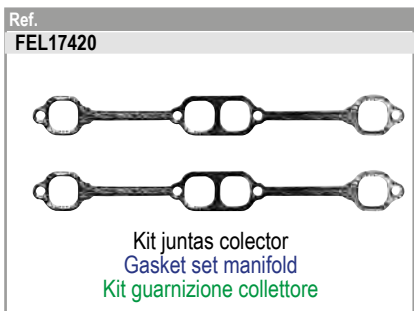
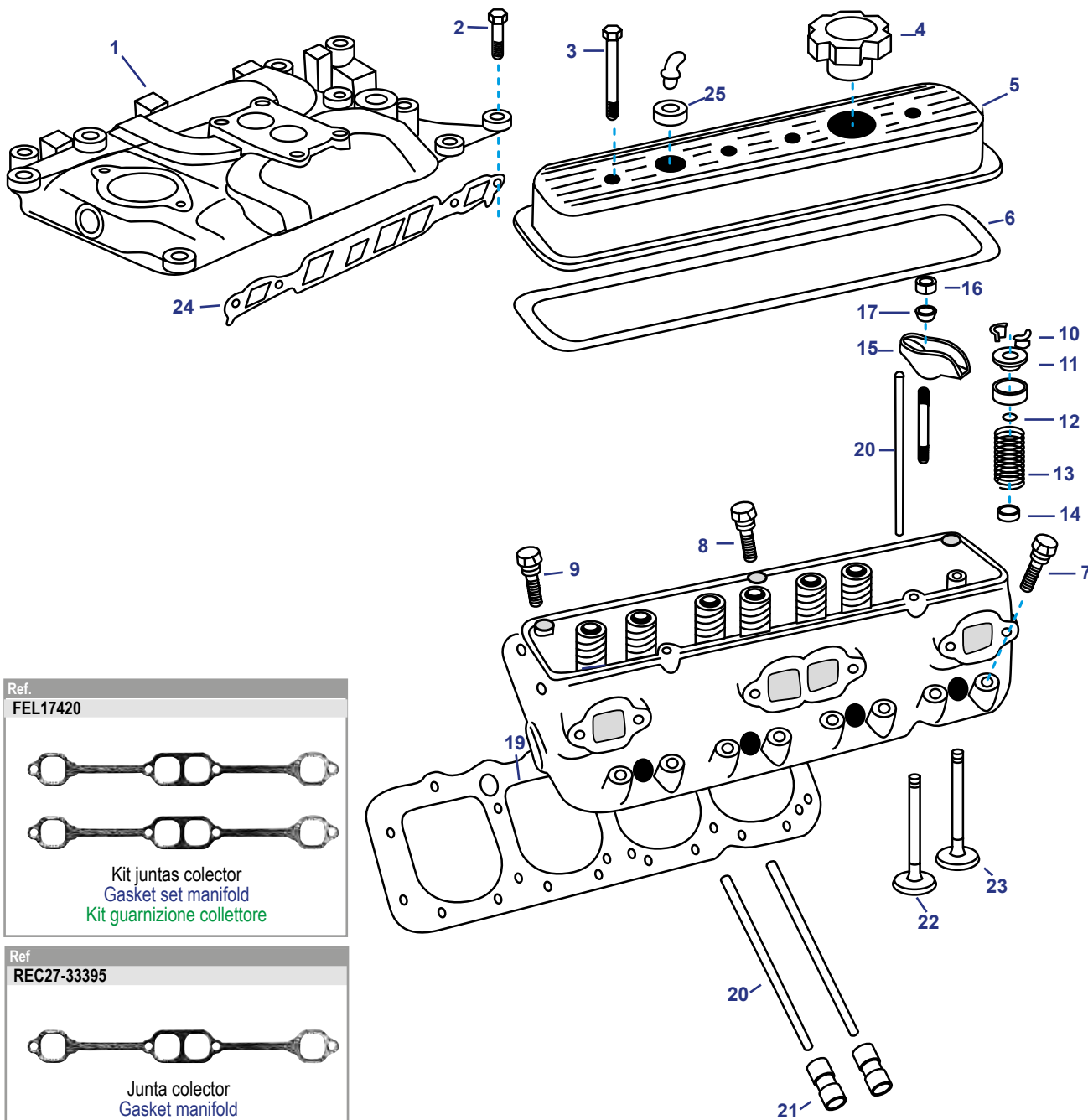



Nº	R.O. / OEM VOLVO	R.O. / OEM MERCURUISER	Ref.	Descripción	Description	Descrizione	Cantidad Quantity Quantità
1	3856270	807289A1	<b>REC425062</b>	COLECTOR: ADMISIÓN 5.7 VORTEC	MANIFOLD: INTAKE 5.7 VORTEC	COLLETTORE ASPIRAZIONE 5.7 VORTEC	1
2	940186	10-806681	<b>MP001204</b>	TORNILLO COLECTOR ADMISIÓN	BOLT INTAKE MANIFOLD	VITE COLLETTORE ASPIRAZIONE	8
3	3856135	10-17344	<b>MP0009-107</b>	TORNILLO TAPA DE VÁLVULA SB	BOLT: VALVE COVER SB	VITE COPERCHIO VALVOLA SB	8
4	3854008	36-18710002	<b>REC6532</b>	TAPÓN ACEITE (1986+)	CAP: OIL FILL (1986+)	TAPPO: PARAOLIO (1986+)	1
4	3853840	17345	<b>REC4804</b>	TAPÓN ACEITE (1978-85)	CAP: OIL FILL (1978-85)	TAPPO: PARAOLIO (1978-85)	1
5	841212	79961T	<b>REC14200</b>	TAPA VÁLVULA 5.0 y 5.7L (1987-88) (Agujeros laterales)	VALVE COVER: 5.0 & 5.7L (1987-88) (Bolt around perimeter)	COPERCHIO VALVOLA: 5.0 e 5.7L (1987-88) (Fori nel perimetro)	1
5	841212	79961T	<b>REC14201</b>	TAPA VÁLVULA 5.0 y 5.7L (-1987) (Agujeros laterales)	VALVE COVER: 5.0 & 5.7L (1987+) (Bolt around perimeter)	COPERCHIO VALVOLA: 5.0 e 5.7L (1987+) (Fori nel perimetro)	1
5	3856928	809996	<b>REC14202</b>	TAPA VÁLVULA 5.0 y 5.7L (1989+) (1 Tapón)	VALVE COVER: 5.0 & 5.7L (1989+) (1 Seal)	COPERCHIO VALVOLA: 5.0 e 5.7L (1989+) (1 tappo)	1
5	3856928	809995	<b>REC14203</b>	TAPA VÁLVULA 5.0 y 5.7L (1989+) (2 Tapones)	VALVE COVER: 5.0 & 5.7L (1989+) (2 Seals)	COPERCHIO VALVOLA: 5.0 e 5.7L (1989+) (2 tappi)	1

Nº	R.O. / OEM VOLVO	R.O. / OEM MERCURUISER	Ref.	Descripción	Description	Descrizione	Cantidad Quantity Quantità
6	835096	27-52202	FEL17930	JUNTA TAPA VÁLVULA 5.0 y 5.7L (-1986) (Agujeros laterales)	GASKET VALVE COVER 5.0 & 5.7L (1986+) (Bolt around perimeter)	GUARNIZIONE COPERCHIO VALVOLA 5.0 e 5.7L (1986+) (Vite nel perimetro)	1
6	3852687	27-17467	FEL17931	JUNTA TAPA VÁLVULA 5.0 y 5.7L (1987+) (Agujeros centrales)	GASKET VALVE COVER 5.0 & 5.7L (-1987) (Central Bolts)	GUARNIZIONE COPERCHIO VALVOLA 5.0 e 5.7L (-1987) (Vite nel centro)	1
7	3856124	10-11968	MP0007-029	TORNILLO CORTO: CULATA	BOLT: CYLINDER HEAD SHORT	VITE CORTA TESTATA	16
8	3856123	10-11967 1	MP0007-028	TORNILLO MEDIO: CULATA	BOLT: CYLINDER HEAD MED	VITE MEDIA TESTATA	4
9	3856122	10-11966	MP0007-027	TORNILLO LARGO: CULATA	BOLT: CYLINDER HEAD LONG	VITE LUNGA TESTATA	14
10	3855823	28-54797 1		CHAVETA: VÁLVULA DE ADMISIÓN 350	KEY: VALVE STEM 350	CHIAVETTA: VALVOLA ASPIRAZIONE 350	16
11	3853229	48348	MP0007-378	TAPÓN: MUELLE VÁLVULA	CAP: INLET VALVE SPRING	TAPPO: MOLLA VALVOLA	8
12	3854956	26-34217	REC26-34217	RETÉN ACEITE: VÁLVULA	SEAL: VALVE STEM OIL	PARAOILIO: VALVOLA	16
13	3853227	24-48347	REC11500	MUELLE VÁLVULA	SPRING: VALVE	MOLLA VALVOLA	16
13	21605360	24-48347 1	RM24-483471	MUELLE VÁLVULA (1996+)	SPRING: VALVE (1996+)	MOLLA VALVOLA (1996+)	16
14	3853226	26-97664	REC70817B	RETÉN: VÁLVULA ADMISIÓN	SEAL: INTAKE VALVE STEM	TENUTA: VALVOLA ASPIRAZIONE	8
15	3853158	35329	REC10352	BALANCÍN: VÁLVULA	ROCKER ARM: VALVE	BILANCERE: VALVOLA	16
16	3853004	11-34516	MP0007-122	TUERCA: BRAZO BALANCÍN	NUT: VALVE ROCKER ARM	DADO: VALVOLA BILANCERE	16
17	3853198	59340	RM59340	ROTOR: VÁLVULA	ROTATOR: VALVE	ROTORE: VALVOLA	8
18			FirstMate 	CULATA	HEAD: CYLINDER	TESTATA	2
19	3853380	27-75611	FEL17020	JUNTA: CULATA 5.0L	GASKET: CYLINDER HEAD 5.0L	GUARNIZIONE: TESTATA 5.0L	2
19	3853380	27-75611	FEL17030	JUNTA : CULATA 5.7L	GASKET: CYLINDER HEAD 5.7L	GUARNIZIONE: TESTATA 5.7L	2
20	3853157	99948	REC12003	VARILLA: VÁLVULA (1987-95) 5.0 y 5.7L	ROD: VALVE (1987-95) 5.0 & 5.7L	ASTA VALVOLA (1987-95) 5.0 e 5.7L	16
20	3863058	173391	REC12004	VARILLA: VÁLVULA (1996+) 5.0 y 5.7L	ROD: VALVE (1996+) 5.0 & 5.7	ASTA VALVOLA (1996+) 5.0 e 5.7L	16
20	3853157	99948	REC12000	VARILLA: VÁLVULA (-1986) 5.0 y 5.7L	ROD: VALVE (-1986) 5.0 & 5.7L	ASTA VALVOLA (-1986) 5.0 e 5.7L	16
21	3853954	17340T	REC14002	EMPUJADOR VÁLVULA	LIFTER: VALVE	ALZA VALVOLA	16
21	3856127	72638	MP0017-097	EMPUJADOR VÁLVULA (1996+) 5.0 y 5.7L	LIFTER: VALVE (1996+) 5.0 & 5.7L	ALZA VALVOLA (1996+) 5.0 e 5.7L	16
22	856368	87284	REC13502	VÁLVULA ESCAPE 5.0L (38 - 8,7 - 126) (2 ranuras)	VALVE: EXHAUST 5.0L (38 - 8,7 - 126) (2 slots)	VALVOLA SCARICO 5.0 (38-8,7-126) (2 Slot)	8
22			REC13508	VÁLVULA ESCAPE 5.0L & 5.7L (38-9,4-125) (2 ranuras)	VALVE: EXHAUST 5.0L & 5.7L (38-9,4-125) (2 slots)	VALVOLA SCARICO 5.0 e 5.7L (38-9,4-125) (2 Slot)	8
22			REC13500	VÁLVULA ESCAPE 5.0L & 5.7L (38-8,7-125) (2 ranuras)	VALVE: EXHAUST 5.0L & 5.7L (38-8,7-125) (2 slots)	VALVOLA SCARICO 5.0 e 5.7L (38-8,7-125) (2 Slot)	8
22	3855808		REC13505	VÁLVULA ESCAPE 5.0L & 5.7L VORTEC (1996+) (38-8,7-125) (1 ranura)	VALVE: EXHAUST 5.0L & 5.7L VORTEC (1996+) (38-8,7-125) (1 slot)	VALVOLA SCARICO 5.0 e 5.7L VORTEC (1996+) (38-8,7-125) (1 Slot)	8
23			REC13509	VÁLVULA ADMISIÓN 5.0L (47 - 8,8 - 125) (2 ranuras)	VALVE: INTAKE 5.0L (47 - 8,8 - 125) (2 slots)	VALVOLA ASPIRAZIONE 5.0L (47-8,8-125) (2 slot)	8
23	841873		REC13510	VÁLVULA ADMISIÓN 5.7L (49 - 8,8 - 124) (2 ranuras)	VALVE: INTAKE 5.7L (49 - 8,8 - 124) (2 slots)	VALVOLA ASPIRAZIONE 5.7L (49-8,8-124) (2 slot)	8
23	3855810		REC13507	VÁLVULA ADMISIÓN 5.7L VORTEC (1996+) (49-8,8-124) (1 ranura)	VALVE: INTAKE 5.7L VORTEC (1996+) (49-8,8-124) (1 slot)	VALVOLA ASPIRAZIONE 5.7L VORTEC (1996+) (49-8,8-124) (1 slot)	8
23		802555	RM802555	VALVE: ADMISIÓN 5.0L VORTEC 1996+ (46,5-8,7-124) (1 ranura)	VALVE: INTAKE 5.0L VORTEC (1996+) (46,5-8,7-124) (1 slot)	VALVOLA ASPIRAZIONE 5.0L VORTEC (1996+) (46,5-8,7-124) (1 Slot)	8
24	856365	27-17145	FEL17320	KIT JUNTAS: COLECTOR ADMISIÓN PREVORTEC	GASKET KIT: INTAKE MANIFOLD PREVORTEC	KIT GUARNIZIONE: COLLETTORE ASPIRAZIONE PREVORTEC	2
24	3857662	27-807473A1	REC27-807473A1	KIT JUNTAS: COLECTOR ADMISIÓN VORTEC	GASKET KIT: INTAKE MANIFOLD VORTEC	KIT GUARNIZIONE: COLLETTORE ASPIRAZIONE VORTEC	2
25			REC6507	ANILLO: TAPA VÁLVULA 5.0 y 5.7L (1986+)	GROMMETT: VALVE COVER 5.0 & 5.7L (1986+)	ANELLO: COPERCHIO VALVOLA 5.0 e 5.7L (1986+)	2
25	835415	8M0071559	RECTW9760	ANILLO: TAPA VÁLVULA 5.0 y 5.7L (1978-85)	GROMMETT: VALVE COVER 5.0 & 5.7L (1978-85)	ANELLO: COPERCHIO VALVOLA 5.0 e 5.7L (1978-85)	2

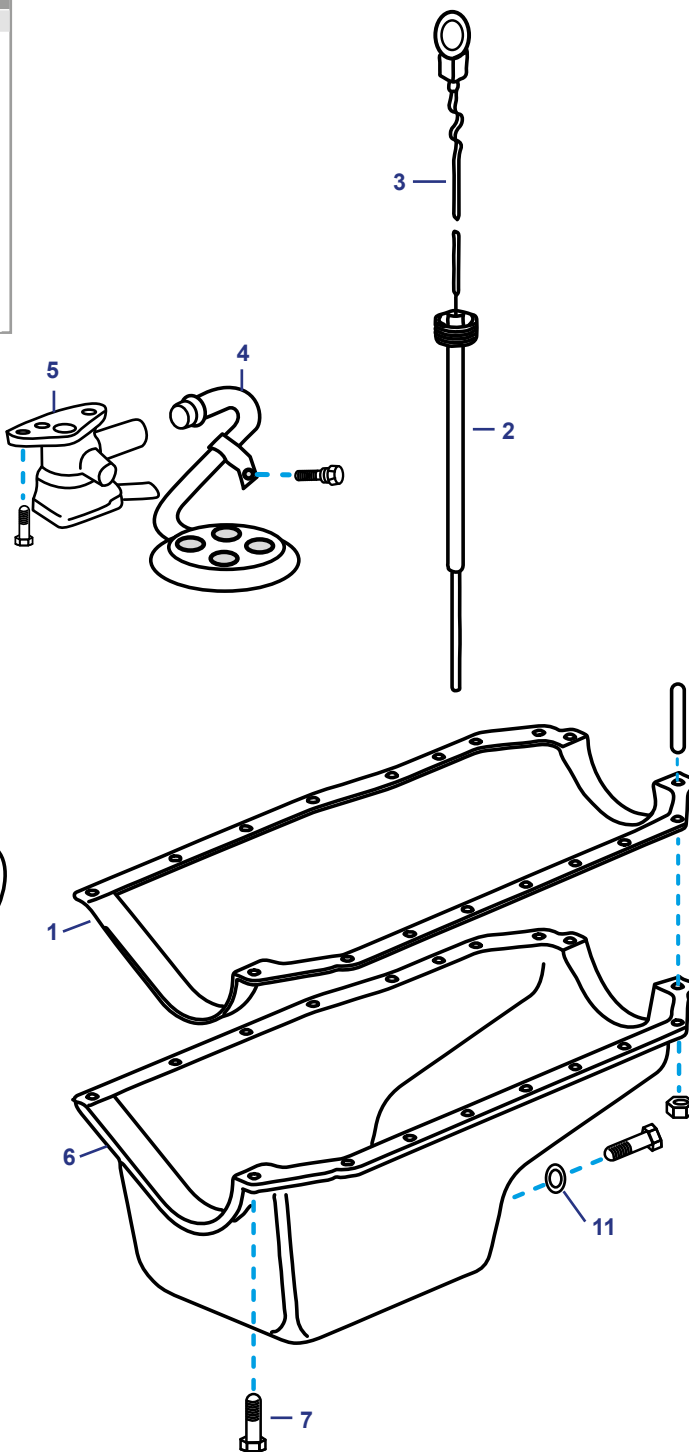
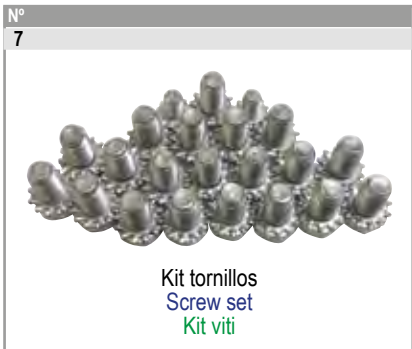
V8 BLOQUE PEQUEÑO / SMALL BLOCK / BLOCCO PICCOLO  
5.0, 5.7 & 6.2L



Nº	R.O. / OEM VOLVO	R.O. / OEM MERCURISER	Ref.	Descripción	Description	Descrizione	Cantidad Quanty Quantità
1	855729	27-52236	FEL17980	JUNTAS CÁRTER (4 juntas varilla aceite babor)	GASKET OIL PAN (4 gaskets port dipstick)	GUARNIZIONE COPPA OLIO (4 guarnizioni asta, livello babordo)	1
1	855729	27-52236	FEL17981	JUNTAS CÁRTER (4 juntas varilla aceite estribor)	GASKET OIL PAN (4 gaskets stbd. dipstick)	GUARNIZIONE COPPA OLIO (4 guarnizione asta, livello tribordo)	1
1	3856138	27-13865 1	FEL17982	JUNTAS CÁRTER (1 junta + retén trasero 1 pieza)	GASKET OIL PAN (1 gasket + 1 piece rear seal)	GUARNIZIONE COPPA OLIO (1 guarnizione + 1 tenuta posteriore)	1
1	841240	27-85917A1	FEL17983	JUNTAS CÁRTER (1 junta + retén trasero 2 piezas)	GASKET OIL PAN (1 gasket + 2 pieces rear seal)	GUARNIZIONE COPPA OLIO (1 guarnizione + 2 tenute posteriore)	1
2		805384T	MP0307-002	TUBO VARILLA ACEITE 5.0L, 5.7L	DIPSTICK TUBE 5.0L, 5.7L	ASTA LIVELLO DEL TUBO DI 5.0L, 5.7L	1
2			MP373201	TUBO VARILLA ACEITE PLASTISOLPAN SB	DIPSTICK TUBE PLASTISOLPAN SB	ASTA LIVELLO DEL TUBO PLASTISOLPAN SB	1
3		861942T2	REC551455	VARILLA ACEITE 5.0L, 5.7L	DIPSTICK 5.0L, 5.7L	ASTA LIVELLO DEL TUBO 5.0L, 5.7L	1
3		861942T3	MP371663	VARILLA ACEITE 5.7V (1999+)	DIPSTICK 5.7V (1999+)	ASTA LIVELLO DEL TUBO 5.7V (1999+)	1
4		809908 1	MP0007-256	FILTRO ACEITE (con tubo)	SCREEN OIL 350 (with tube)	FILTRO OLIO 350 (con tubo)	1
5	3853851	809907002	REC14101	BOMBA ACEITE	PUMP OIL 350	POMPA OLIO 350	1
6	3857674	87758A1	REC15352	CÁRTER 350 (-1986)	OIL PAN 350 (-1986)	COPPA OLIO 350 (-1986)	1
6	3850822	13840A1	REC15353	CÁRTER 350 (1987+)	OIL PAN 350 (1987+)	COPPA OLIO 350 (1987+)	1
6		8809910	REC809910	CÁRTER 5.0, 5.7, 6.2 nuevo (MPI)	OIL PAN 5.0, 5.7, 6.2 new (MPI)	COPPA OLIO 5.0, 5.2, 6.2 nuovo (MPI)	
7	940100	10-55715	RECPNRS-1100	KIT TORNILLOS	BOLTS KIT	KIT VITI	1
8			FEL17120	KIT JUNTAS (4 juntas cárter 2 piezas retén)	GASKET SET (4 oil pan gaskets 2 pieces rear seal)	KIT GUARNIZIONE (4 guarnizione coppa olio, 2 tenute posteriori)	1
8			FEL17125	KIT JUNTAS (1 junta cárter, 1 pieza retén)	GASKET SET (1 oil pan gasket 1 piece rear seal)	KIT GUARNIZIONE (1 guarnizione coppa olio, 1 tenuta posteriori)	1
8			FEL17124	KIT JUNTAS (1 junta cárter, 1 retén tapa distribución plástico)	GASKET SET (1 oil pan gasket, 1 seal plastic dist.cap)	KIT GUARNIZIONE (1 guarnizione coppa olio, 1 coperchio distribuzione in plastica)	1
9			MPI305-0380	MANGUERA DE VACIADO MCM-OMC 1/2"	DRAIN HOSE MCM-OMC 1/2"	TUBO DI SCARICO MCM-OMC 1/2"	1
9			MPI307-0380	MANGUERA DE VACIADO VOLVO 3/4"	DRAIN HOSE VOLVO 3/4"	TUBO DI SCARICO VOLVO 3/4"	1
9			MPI309-0380	MANGUERA DE VACIADO FORD 14 mm	DRAIN HOSE Metric FORD 14 mm	TUBO DI SCARICO FORD 14 mm	1
11	3851981	27-49955	REC27-49955	JUNTA	GASKET	GUARNIZIONE	1
12				FILTRO ACEITE V8	V8 OIL FILTER	FILTRO OLIO V8	1

**V8 BLOQUE PEQUEÑO / SMALL BLOCK / BLOCCO PICCOLO 5.0 & 5.7L**

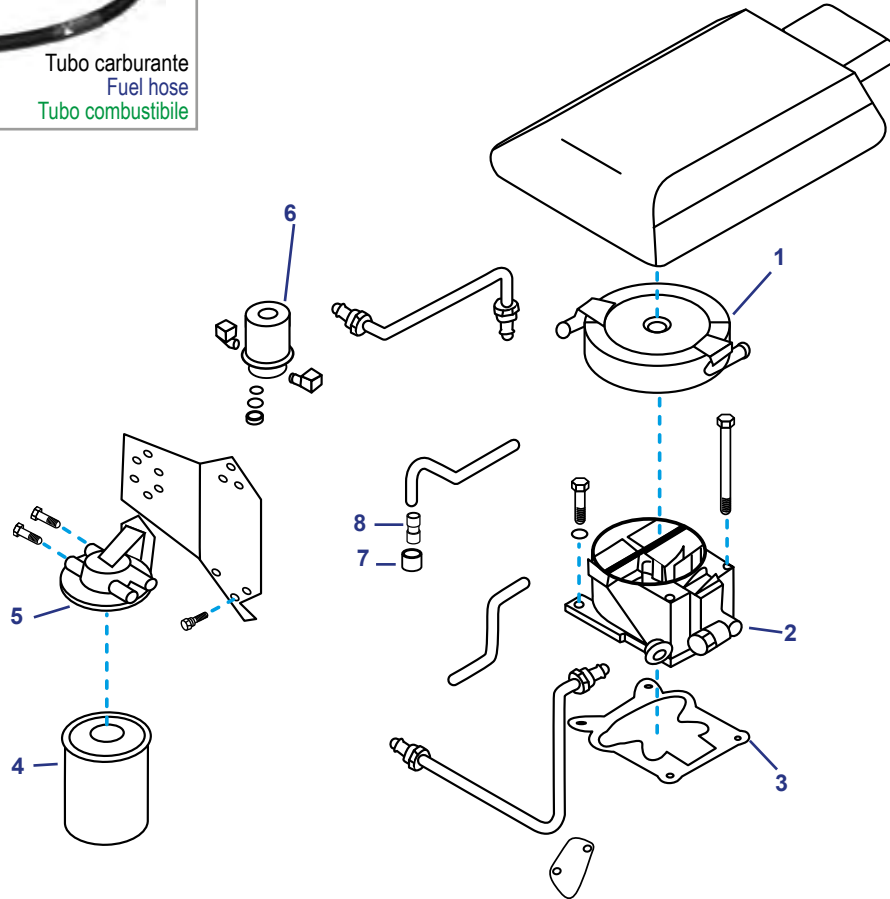
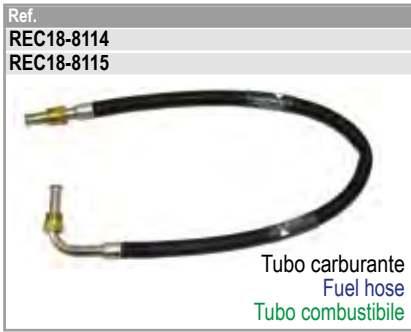

Nº	R.O. / OEM VOLVO	R.O. / OEM MERCUISER	Ref.	Descripción	Description	Descrizione	Cantidad Quantity Quantità
1			REC805298A1	PARALLAMAS 350	FLAME ARRESTOR: 350	ANTIFIAMMA 350	1
2				CARBURADOR	CARBURETOR	CARBURATORE	1
3				JUNTA CARBURADOR	GASKET: CARBURETOR	GUARNIZIONE CARBURATORE	1
4				FILTRO COMBUSTIBLE (separador agua)	FILTER: FUEL/WATER SEP.	FILTRO CARBURANTE (separatore d'acqua)	1
5			REC25000	BRACKET	BRACKET	BRACKET	2
6				BOMBA COMBUSTIBLE	FUEL PUMP	POMPA CARBURANTE	1
7			MP806200	ANILLO: TAPA VÁLVULA	GROMMET: VALVE COVER	ANELLO: COPERCHIO VALVOLA	1
8				CONECTOR DE VENTI- LACIÓN	FITTING: VENT HOSE	CONNETTORE DI SFIATO	1

# V8 BLOQUE PEQUEÑO / SMALL BLOCK / BLOCCO PICCOLO 5.0 & 5.7L

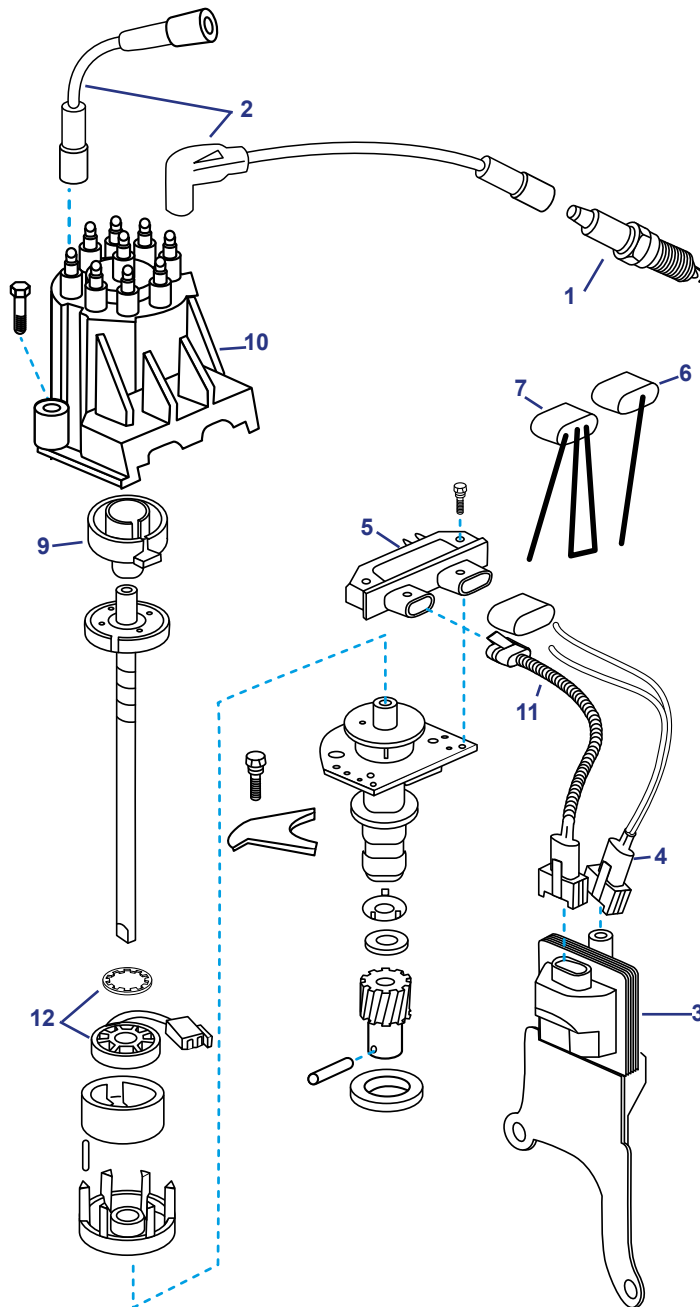

Nº 8  
 Distribuidor electrónico  
 Distributor: Electronic  
 DISTRIBUZIONE electronic

Para otros modelos consultar:  
 For other models see:  
 Per altri modelli vedi:



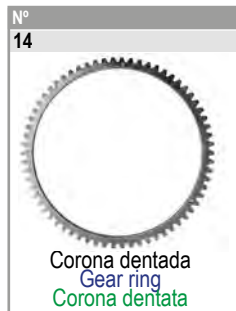
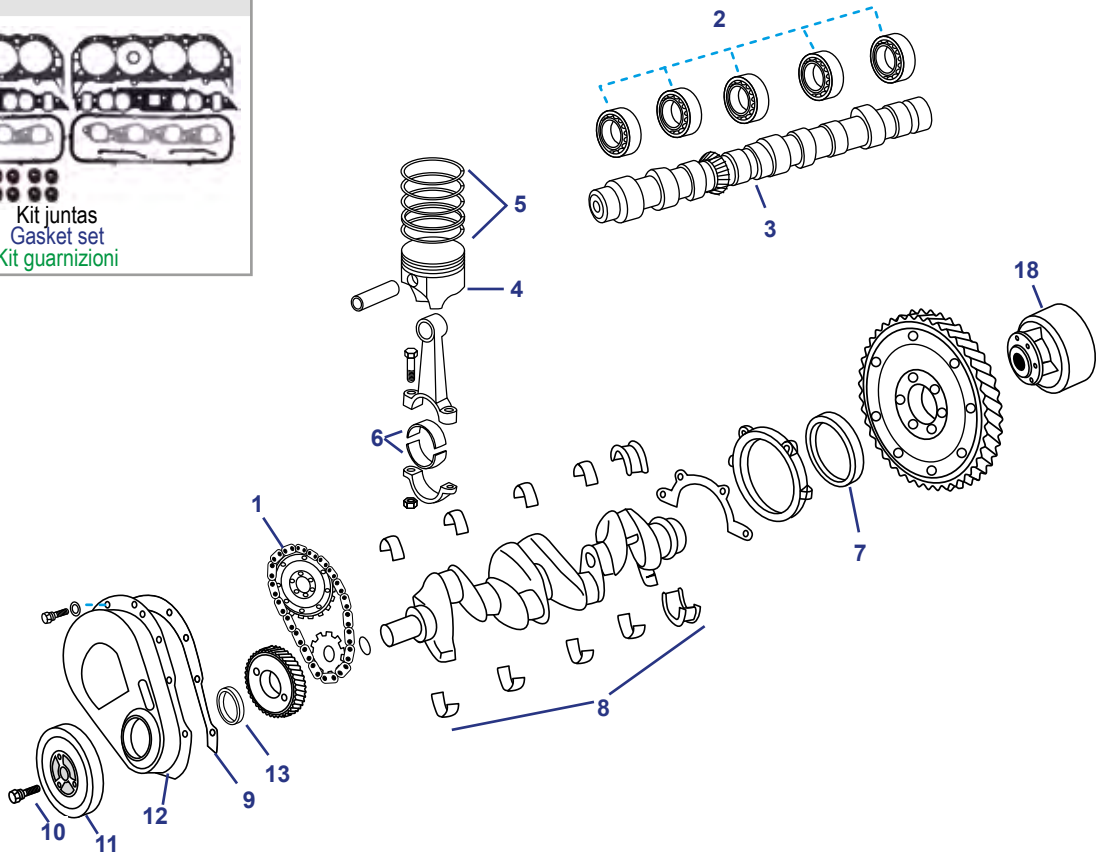
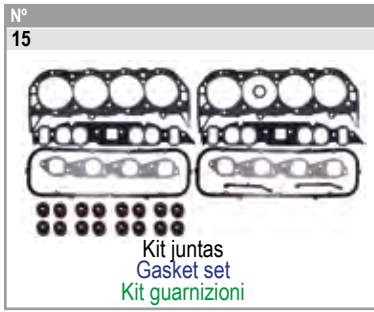

Nº	R.O. / OEM VOLVO	R.O. / OEM MERCURUISER	Ref.	Descripción	Description	Descrizione	Cantidad Quantity Quantità
1				BUJÍAS: V8	SPARK PLUG: V8	CANDELE: V8	8
2				KIT CABLE IGNICIÓN V8	IGNITION WIRE: SET V8	KIT CAVI INIEZIONE V8	1
3	3854002	898253T27	REC3854002	BOBINA: DELCO E.I.	COIL: DELCO E.I.	BOBINA DELCO E.I.	1
4			REC500442	CABLE BOBINA A DISTRIBUIDOR	WIRE LEAD: COIL DIST	CAVO BOBINA DISTRIBUZIONE	1
5	3854003	811637001	REC3854003	MÓDULO DELCO	MODULE: DELCO	MODULO DELCO	1
6			REC294005	CABLE IGNICIÓN: INTERRUPTOR	IGNITION WIRE: SHIFT	CAVO INIEZIONE: INTERRUPTORE	1
7		91-888863	REC91-888863	HERRAMIENTA	TOOL: TIMING	STRUMENTO	1
8	3857449	805222A1	REC805222A1	DISTRIBUIDOR V8 DELCO E.I. (5, 9 y 10 incluidos)	DISTRIBUTOR V8 DELCO E.I. (5, 9 & 10 included)	DISTRIBUTTORE V8 DELCO E.I. (5, 9 e 10 compresi)	1
9	3862014	8M6001253	REC3854549	ROTOR V8 DELCO E.I.	ROTOR: V8 DELCO E.I.	ROTORE V8 DELCO E.I.	1
10	3854548	808483T3	REC3854548	TAPA: V8 DELCO E.I.	CAP: V8 DELCO E.I.	COPERCHIO V8 DELCO E.I.	1
11	3854084	84-817376T01	REC84-817376T01	CABLES BOBINA A MÓDULO	WIRE LEAD: COIL HARNESS	CAVI BOBINA A MODULO	1
12	3854001	811639T	REC3854001	MÓDULO	MODULE	MODULO	1

**V8 BLOQUE GRANDE / BIG BLOCK / BLOCCO GRANDE 7.4L & 8.2L**



Nº	R.O. / OEM VOLVO	R.O. / OEM MERCURUISER	7.4L	8.2L	Descripción	Description	Descrizione	Cantidad Qty Quantità
1	856620	43-86481 + 86482 + 75588	REC12504		KIT CADENA DISTRIBUIDOR MKIV	KIT TIMING CHAIN MKIV	KIT CATENA DISTRIBUZIONE MKIV	1
1	3853506		REC12505	REC12505	KIT CADENA DISTRIBUIDOR GEN V y VI	KIT TIMING CHAIN GEN V & VI	KIT CATENA DISTRIBUZIONE GEN V e VI	1
2		23-85684	REC13017		KIT COJINETE: ÁRBOL DE LEVAS MKIV	BEARING KIT: CAMSHAFT MKIV	KIT CUSCINETTO: ALBERO A CAMME MKIV	1
2		23-85684	REC23-85684	REC23-85684	KIT COJINETE: ÁRBOL DE LEVAS GEN V	BEARING KIT: CAMSHAFT GENE V	KIT CUSCINETTO: ALBERO A CAMME GENE V	1
3	3855034	431-4734	REC10254	REC10255	ÁRBOL DE LEVAS MKIV y GENE V	CAMSHAFT: MKIV & GENE V	ALBERO A CAMME MKIV e GEN V	1
4	856589	737-879194035	REC10011		PISTÓN: MKIV STD	PISTON: MKIV Std	PISTONE: MKIV STD	8
4		737-5536T	REC10014		PISTÓN: MKIV STD MAGNUM	PISTON: MKIV Std MAGNUM	PISTONE: MKIV STD MAGNUM	8
4	856590	737-6615T 1	REC10012		PISTÓN: MKIV 030	PISTON: MKIV 030	PISTONE: MKIV 030	8
4		737-5537	REC10017		PISTÓN: MKIV 030 MAGNUM	PISTON: MKIV 030 MAGNUM	PISTONE: MKIV 030 MAGNUM	8
4		737-881714T	MP0053-037F8		PISTÓN: GEN V STD (1991-95)	PISTON: GENE V Std (1991-95)	PISTONE: GEN V STD (1991-95)	8
4		737-811602		RM737-811602	PISTÓN: 454 GEN.V 030	PISTON: 454 GEN.V 030	PISTONE: 454 GEN.V 030	
5		39-823098		REC11017	KIT AROS 502 GEN V	RING SET: PISTON 502 GEN. V	KIT ANELLI: PISTON 502 GEN V	
5	856591	39-67127	REC11012		KIT AROS MKIV STD	RING SET MKIV Std	KIT ANELLI MKIV STD	8

Nº	R.O. / OEM VOLVO	R.O. / OEM MERCURISER	7.4L	8.2L	Descripción	Description	Descrizione	Cantidad Qty Quantità
5		39-67127	REC11019		KIT AROS MKIV STD MAGNUM	RING SET MKIV Std MAGNUM	KIT ANELLI MKIV STD MAGNUM	8
5	856592	39-68128	REC11013		KIT AROS MKIV 030	RING SET MKIV 030	KIT ANELLI MKIV 030	8
5		39-67128	REC11018		KIT AROS MKIV 030 MAGNUM	RING SET MKIV 030 MAGNUM	KIT ANELLI MKIV 030 MAGNUM	8
5		39-827651T	REC11014		KIT AROS GENE V y VI STD (Usar código GM 4XW, 5XW, 4XX, 5XX, 4XA, 5XA)	RING SET GENE V & VI Std (use code GM 4XW, 5XW, 4XX, 5XX, 4XA, 5XA)	KIT ANELLI GENE V e VI STD (utilizzare il codice GM 4XW, 5XW, 4XX, 5XX, 4XA, 5XA)	8
5		29-850447	REC11015		KIT AROS GENE V y VI 030 (Usar código GM 4XW, 5XW, 4XX, 5XX, 4XA, 5XA)	RING SET GENE V & VI 030 (use code GM 4XW, 5XW, 4XX, 5XX, 4XA, 5XA)	KIT ANELLI GENE V e VI 030 (utilizzare il codice GM 4XW, 5XW, 4XX, 5XX, 4XA, 5XA)	8
6		23-85726001	REC13019		COJINETE BIELA GEN V	BEARING CONNECTING ROD GEN V	CUSCINETTO BIELLA GEN V	8
6		23-85691	REC13018		COJINETE BIELA GEN V, GEN V 010 & MKIV 010	BEARING CONNECTING ROD GEN V 010 & MKIV 010	CUSCINETTO BIELLA GEN V 010 & MKIV 010	8
7		26-811554		REC26-811554	RETÉN ACEITE: CIGÜEÑAL TRASERO NR	SEAL: CRANKSHFT OIL REAR NR	PARAOLIO: ALBERO MOTORE POSTERIORE NR	1
7	856580	26-14756	REC26-14756	REC26-14756	RETÉN: CIGÜEÑAL 454 MKIV	SEAL: CRANKSHAFT 454 MKIV	PARAOLIO: ALBERO MOTORE 454 MKIV	1
7		26-75980	FEL17740	FEL17740	RETÉN: CIGÜEÑAL CONTRAROTACIÓN	SEAL: CRANKSHAFT OPOSITE ROTATION	PARAOLIO: ALBERO MOTORE CONTROROTANTE	1
8		23-818473	REC13020	REC13020	KIT COJINETE CIGÜEÑAL (MKIV, GENE V, GENE VI)	KIT BEARING CRANKSHAFT (MKIV, GENE V, GENE VI)	KIT CUSCINETTO ALBERO MOTORE (MKIV, GENE V, GENE VI)	1
8		23-818476	REC13021	REC13021	KIT COJINETE CIGÜEÑAL (MKIV, GENE V, GENE VI) 010	KIT BEARING CRANKSHAFT (MKIV, GENE V, GENE VI - 010)	KIT CUSCINETTO ALBERO MOTORE (MKIV, GENE V, GENE VI) 010	1
9	856608	27-54529	REC27-54529	REC27-54529	JUNTA: TAPA DISTRIBUIDOR MKIV	GASKET: TIMING COVER MKIV	GUARNIZIONE: COPERCHIO DISTRIBUZIONE MKIV	1
9		27-850456	REC27-850456		JUNTA TAPA DISTRIBUCIÓN GEN V & VI (silicona)	GASKET: COVER TIMING GEN V & VI (silicone)	GUARNIZIONE: COPERCHIO DISTRIBUZIONE GEN V & VI (in silicone)	
10		10-845627	MP0053-002F3	MP0053-002F3	TORNILLO: CIGÜEÑAL	BOLT: CRANKSHAFT	VITE: ALBERO MOTORE	1
11	976644	811555	MP0053-004F8	MP0053-004F8	AMORTIGUADOR: TORSIONAL 454 NR	DAMPER: TORSIONAL 454 NR	AMMORTIZZATORE: TORSIONALE 454 NR	1
12	856605	66215	REC15255	REC15255	TAPA DISTRIBUIDOR 454 MK IV	COVER: TIMING 454 MK IV	COPERCHIO: DISTRIBUZIONE 454 MK IV	1
12		845610T	MP0053-060	MP0053-060	TAPA: DISTRIBUIDOR GENE V & VI NP (1996+) Junta silicona	COVER: TIMING GENE VI NP (1996+) Silicone Gasket	COPERCHIO DISTRIBUZIONE GENE VI NP (1996+) Guarnizione in silicone	1
13		26-8219471	REC26-8219471	REC26-8219471	RETÉN ACEITE: CIGÜEÑAL FRONTAL GENE IV, V, VI	SEAL: CRANKSHAFT OIL FRONT GENE IV, V, VI	PARAOLIO: ALBERO MOTORE FRONTALE GENE IV, V, VI	1
14			REC157-N	REC157-N	CORONA DENTADA (157 dientes Ø12")	GEAR RING 157 Teeth Ø12")	CORONA DENTATA (157 dente Ø12")	1
14			REC1685	REC1685	CORONA DENTADA (168 dientes Ø13-3/4")	GEAR RING (168 Teeth Ø13-3/4")	CORONA DENTATA (168 dente Ø13-3/4")	1
14			FED416-124	FED416-124	CORONA DENTADA (180 dientes Ø14-1/2")	GEAR RING (180 Teeth Ø14-1/2")	CORONA DENTATA (180 dente Ø14-1/2")	1
15			FEL17240	FEL17241	KIT JUNTAS MKIV	GASKET SET MKIV	KIT GUARNIZIONE MKIV	1
15			FEL17246		KIT JUNTAS MKIV 385, 400, 420, 425HP	GASKET SET MKIV 385, 400, 420 & 425 HP	KIT GUARNIZIONE MKIV 385, 400, 420, 425 HP	1
15			FEL17280	FEL17280	KIT JUNTAS GENE V (sólo EFI)	GASKET SET GENE V (Only EFI)	KIT GUARNIZIONE GENE V (Solo EFI)	1
15			FEL17242	FEL17243	KIT JUNTAS GENE V & VI (Excepto EFI)	GASKET SET GENE V & VI (Except EFI)	KIT GUARNIZIONE GENE V & VI (salvo EFI)	1
15			FEL17242	FEL17201	KIT JUNTAS GENE VI (Excepto EFI)	GASKET SET GENE VI (Except EFI)	KIT GUARNIZIONE GENE VI (salvo EFI)	
15				FEL17248	KIT JUNTAS MKIV	GASKET SET MKIV	KIT GUARNIZIONE MKIV	
15				FEL17249	KIT JUNTAS GENE V	GASKET SET GENE V	KIT GUARNIZIONE GENE V	
15				FEL17281	KIT JUNTAS GENE V EFI	GASKET SET GENE V EFI	KIT GUARNIZIONE V EFI	
15				FEL17207	KIT JUNTAS GENE VI EFI	GASKET SET GENE VI EFI	KIT GUARNIZIONE VI EFI	
16		807757T	REC807757T		POLEA SERPENTINA MCM (Plástico)	SERPENTINE PULLEY MCM (Plastic)	PULEGGIA SERPENTINA MCM (plastica)	1
17			MP514720	MP514720	POLEA DE CIGÜEÑAL DE DOBLE RANURA (Ø6-3/4")	DUAL GROOVE CRANK-SHAFT PULLEY (Ø6-3/4")	PULEGGIA ALBERO MOTORE DE DOPIO SLOT (Ø6-3/4")	1
18					ACOPLE	DUMPLER	ACCOPPIAMENTO	1



**V8 BLOQUE GRANDE / BIG BLOCK / BLOCCO GRANDE 7.4L & 8.2L**

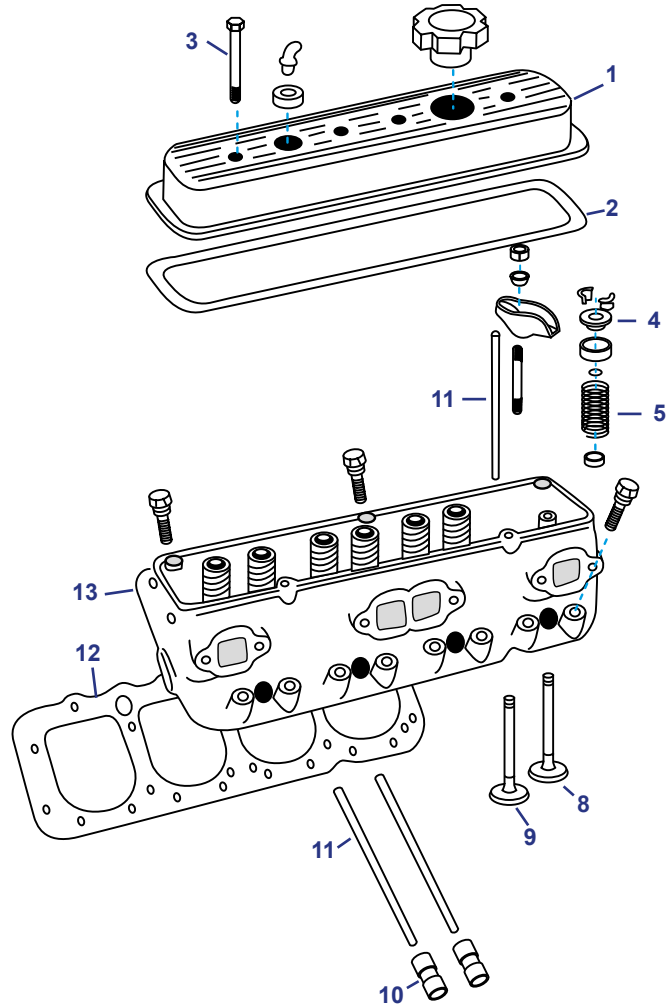
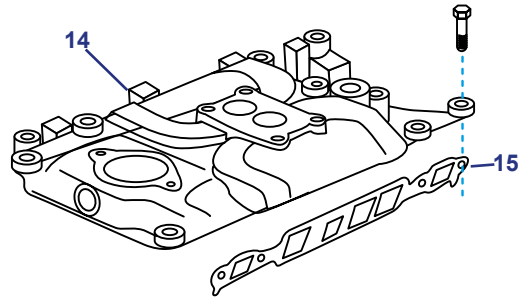

Nº	R.O. / OEM VOLVO	R.O. / OEM MERCURISER	Ref. 7.4L	Ref. 8.2L	Descripción	Description	Descrizione	Cantidad Qty Quantità
1		17671	<b>REC14204</b>		TAPA VÁLVULA: MKIV	VALVE COVER: MKIV	COPERCHIO VALVOLA: MKIV	2
2	3853513	27-811588	<b>FEL17937</b>	<b>FEL17937</b>	KIT JUNTAS: TAPA VÁLVULA GENE V y VI	GASKET KIT: VALVE COVER GENE V & VI	KIT GUARNIZIONE: COPERCHIO VALVOLA GENE V e VI	2
2	856626	27-49121	<b>FEL17935</b>	<b>FEL17935</b>	KIT JUNTAS: TAPA VÁLVULA MKIV	GASKET KIT: VALVE COVER MKIV	KIT GUARNIZIONE: COPERCHIO VALVOLA MKIV	2
3		16-11995	<b>MP0025-107</b>	<b>MP0025-107</b>	TORNILLO: TAPA VÁLVULA	BOLT: VALVE COVER	VITE: COPERCHIO VALVOLA	14
4	3853521	26-75988	<b>REC26-75988</b>	<b>REC26-75988</b>	RETÉN ACEITE: VÁLVULA ADMISIÓN MKIV	SEAL: VALVE STEM OIL MKIV	PARAOILIO: VALVOLA ASPIRAZIONE MKIV	16
4	856572	26-827645	<b>REC26-827645</b>	<b>REC26-827645</b>	RETÉN ACEITE: VÁLVULA ADMISIÓN GENE V y VI	SEAL: VALVE STEM OIL GENE V & VI	PARAOILIO: VALVOLA ASPIRAZIONE GENE V e VI	16
5	3854765	24-14754T 24-801879T	<b>REC11502</b>	<b>RM24-801879</b>	MUELLE: VÁLVULA MKIV, GENE V	SPRING: VALVE MKIV, GENE V	MOLLA: VALVOLA MKIV, GENE V	16
5	3853543		<b>RM24-850465T</b>		MUELLE: VÁLVULA GENE VI (1996-98)	SPRING: VALVE GENE VI (1996-98)	MOLLA: VALVOLA GENE VI (1996-98)	16

Nº	R.O. / OEM VOLVO	R.O. / OEM MERCUISER	Ref. 7.4L	Ref. 8.2L	Descripción	Description	Descrizione	Cantidad Qty Quantità
6	3854766	10-8M0000482	MP0003-027	MP0003-027	TORNILLO LARGO CULATA	BOLT: CYL HEAD LONG	VITE LUNGA TESTATA	24
7	3854767	10-8M0000483	MP0003-029	MP0003-029	TORNILLO CORTO CULATA	BOLT: CYL HEAD SHORT	VITE CORTA TESTATA	8
8	3853485	49134	REC13511		VÁLVULA: ADMISIÓN MKIV, GEN V y VI (52,5-9,2-133) (1982-98)	VALVE: INTAKE MKIV, GEN V & VI (52,5-9,2-133) (1982-98)	VALVOLA ASPIRAZIONE MKIV, GENE V e VI (52,5-9,2-133) (1982-98)	8
8				REC13511	VÁLVULA: ADMISIÓN MKIV, (52,5-9,2-133) (1986-88)	VALVE: INTAKE MKIV, (52,5-9,2-133) (1986-88)	VALVOLA ASPIRAZIONE MKIV (52,5-9,2-133) (1986-88)	8
8	3853349	801877		RM801877	VÁLVULA ADMISIÓN (1988-95) MKIV, GENE V (56-9,3-133)	VALVE: INTAKE (1988-95) MKIV, GENE V (56-9,3-133)	VALVOLA ASPIRAZIONE (1988-95) MKIV, GENE V (56-9,3-133)	8
9		67861	REC13512		VÁLVULA ESCAPE: MKIV (44-9,2-136) (1982-87)	VALVE: EXHAUST MKIV (44-9,2-136) (1982-87)	VALVOLA SCARICO: MKIV (44-9,2-136) (1982-87)	8
9				REC13512	VÁLVULA ESCAPE: MKIV (44-9,2-136) (1986-88)	VALVE: EXHAUST MKIV (44-9,2-136) (1986-88)	VALVOLA SCARICO: MKIV (44-9,2-136) (1986-88)	8
9	856566	818962	REC13513		VÁLVULA ESCAPE: MKIV, GENE V y VI (44-9,2-136) (1988-98)	VALVE: EXHAUST MKIV, GEN V & VI (44-9,2-136) (1988-98)	VALVOLA SCARICO: MKIV GENE V e VI (44-9,2-136) (1988-98)	8
9	3853350	816962		RM816962	VÁLVULA ESCAPE (1988-97) MKIV Y GENE V (48-9,3-136)	VALVE EXHAUST (1988-97) MKIV & GENE V (48-9,3-136)	VALVOLA SCARICO: (1988-97) MKIV E GENE V (48-9,3-136)	8
10	3853954	72638	REC14000		ELEVADOR VÁLVULA MKIV	LIFTER VALVE MKIV	ALZA VALVOLA MKIV	16
10		811583		RM811583				
10	3854099	811584	REC14003	REC14003	ELEVADOR VÁLVULA GENE V	LIFTER VALVE GEN V	ALZA VALVOLA GENE V	16
11	3853483	848263	REC12005	REC12006	VARILLA: VÁLVULA ADMISIÓN MKIV (Ø10)	PUSH ROD: INTAKE VALVE MKIV (Ø10)	ASTICELLA: VALVOLA ASPIRAZIONE (Ø10)	8
11	3853483	811581	REC12007		VARILLA: VÁLVULA ADMISIÓN MKIV (Ø8) GEN V	PUSH ROD: INTAKE VALVE MKV (Ø8) GEN V	ASTICELLA: VALVOLA ASPIRAZIONE MKIV (Ø8) GEN V	8
11		848262		REC12010	EJE ÉMBOLO: VÁLVULA ESCAPE MKIV (Ø8) GEN V	PUSH ROD: EXHAUST VALVE MKIV (Ø8) GEN V	ASTA DI BIELLA: VALVOLA SCARICO MKIV (Ø8) GEN V	6
11		848266	REC12008					
11		811582	REC12009					
12	856575	27-8M0049045	FEL17040		JUNTA: CULATA MKIV	GASKET: CYL HEAD MKIV	GUARNIZIONE: TESTATA MKIV	2
12		27-811207		FEL17049				
12	3853511	27-879150141	FEL17042		JUNTA CULATA GEN V y VI	GASKET: CYL HEAD GEN V & VI	GUARNIZIONE TESTATA GEN V e VI	2
12		27-879150139		FEL17042				
12				FEL17046	JUNTA: CULATA 385, 400, 420, 425 HP	GASKET: CYL HEAD 385, 400, 420, 425 HP	GUARNIZIONE: TESTATA MKIV 385, 400, 420, 425HP	2
12	3853587	24-811546		FEL17048	JUNTA CULATA MKIV, GENE V Y VI	GASKET CYL HEAD MKIV, GENE V & VI	GUARNIZIONE TESTATA MKIV, GENE V e VI	2
12		27-811546		FEL17048	JUNTA CULATA 8.9L (525 y 950 HP)	GASKET CYL HEAD 8.9L (252 & 950 HP)	GUARNIZIONE TESTATA 8.9L (252 e 950 HP)	2
12		27-811546		FEL17048	JUNTA CULATA 9.4L (750 HP)	GASKET CYL HEAD 9.4L (750 HP)	GUARNIZIONE TESTATA 9.4L (750 HP)	2
13			FirstMate		CULATA	HEAD	TESTATA	2
14	3854100	811575T	MP425113		COLECTOR ADMISIÓN: MKIV y GENE V	MANIFOLD INTAKE: MKIV & GENE V	COLLETTORE ASPIRAZIONE: MKIV e GENE V	1
14		72608		MP425149				
15	856616	27-65184	FEL17340		KIT JUNTAS COLECTOR ADMISIÓN: MKIV, GEN V y VI	GASKET KIT, MANIFOLD INTAKE: MKIV, GEN V & VI	KIT COLLETTORE ASPIRAZIONE: MKIV, GEN V e VI	2
15		27-805722A1		FEL17341				
15	3854095	27-8M0050225	FEL17342		KIT JUNTAS COLECTOR ADMISIÓN: GEN V y VI EFI (-1997)	GASKET KIT, MANIFOLD INTAKE: GEN V & VI EFI (-1997)	KIT COLLETTORE ASPIRAZIONE: GEN V e VI EFI (-1997)	2
15		27-805403A1		FEL17342				
15		27-803184	REC27-803184		KIT JUNTAS COLECTOR ADMISIÓN: GEN VI MPI (1998-00)	GASKET KIT, MANIFOLD INTAKE: GEN VI MPI (1998-00)	KIT COLLETTORE ASPIRAZIONE: GEN VI MPI (1998-00)	2

**V8 BLOQUE GRANDE / BIG BLOCK / BLOCCO GRANDE 7.4L & 8.2L**

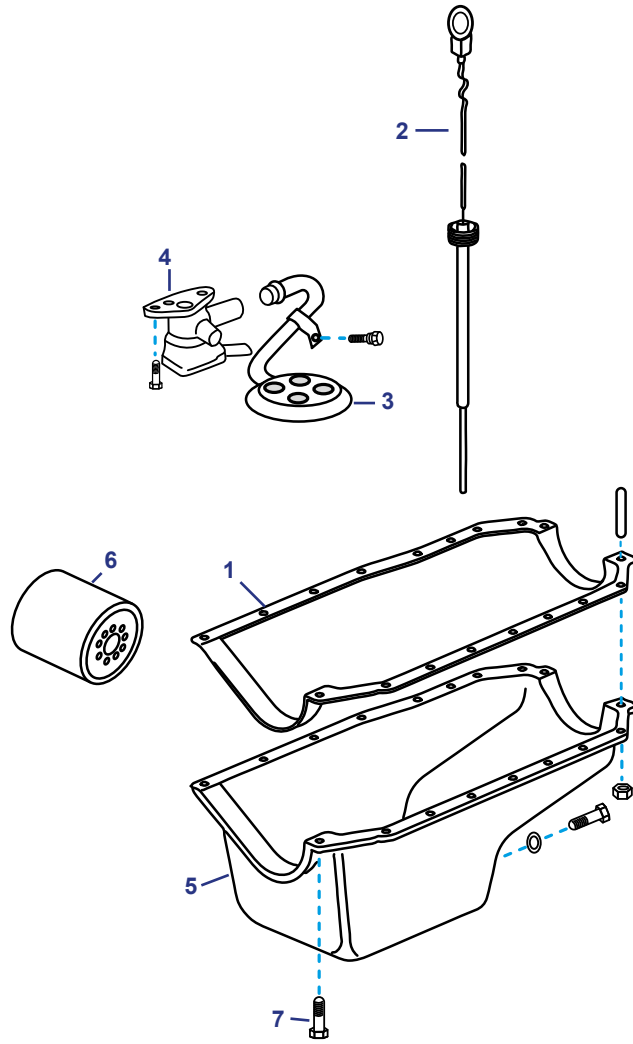

Nº	R.O. / OEM VOLVO	R.O. / OEM MERCURISER	Ref. 7.4L	Ref. 8.2L	Descripción	Description	Descrizione	Cantidad Qty Quantità
1	3853510	27-845628	FEL17986	FEL17986	JUNTA: CÁRTER GEN V y VI	GASKET: OIL PAN GEN V & VI	GUARNIZIONE: COPPA OLIO, GEN V e VI	1
1	856889	27-52550	FEL17985	FEL17985	JUNTA: CÁRTER MKIV	GASKET: OIL PAN MKIV	GUARNIZIONE: COPPA OLIO, MKIV	1
2	856264	861942T9	MP0303-001	MP0303-001	VARILLA ACEITE: 454	DIPSTICK: 454	ASTA DI LIVELLO: 454	1
3			MP0005-256		FILTRO BOMBA ACEITE	SCREEN: OIL PUMP	FILTRO POMPA OLIO	1
4	3855035	808693A1	REC14102		BOMBA ACEITE: GENE IV	PUMP: OIL GENE IV	POMPA OLIO: GENE IV	1
4	3855035	827643	MP0053-255F8		BOMBA ACEITE GENE V	PUMP: OIL GENE V	POMPA OLIO: GENE V	1
5	3855990	845668T	MP370039		CÁRTER 454 PLASTISOL GENE V	OIL PAN: 454 PLASTISOL GENE V	COPPA OLIO 454 PLASTISOL GENE V	1
6					FILTRO ACEITE	OIL FILTER	FILTRO OLIO	2
7			RECPNRS-1101	RECPNRS-1101	KIT TORNILLOS CÁRTER	BOLT OIL PAN KIT	KIT VITI COPPA OLIO	1
8		27-52550	FEL17140	FEL17140	KIT JUNTAS MKIV (4 juntas cárter 2 piezas retén)	GASKET SET MKIV (4 oil pan gaskets 2 rear seal)	KIT GUARNIZIONE MKIV (4 guarnizioni coppa olio 2 pezzi tenuta)	1
8		27-811566	FEL17145	FEL17145	KIT JUNTAS GENE V (1 junta cárter 1 pieza retén)	GASKET SET GENE V (1 oil pan gasket 1 rear seal)	KIT GUARNIZIONE GENE V (1 guarnizione coppa olio 1 tenuta)	1
8		27-845628	FEL17146	FEL17146	KIT JUNTAS GENE VI	GASKET SET GENE VI	KIT GUARNIZIONE GENE VI	1
9			MPI305-0380		TUBO DE VACIADO MCM-OMC 1/2"	DRAIN HOSE MCM-OMC 1/2"	TUBO DI SCARICO MCM-OMC 1/2"	1
9			MPI307-0380		TUBO DE VACIADO VOLVO 3/4"	DRAIN HOSE VOLVO 3/4"	TUBO DI SCARICO VOLVO 3/4"	1
9			MPI309-0380		TUBO DE VACIADO FORD 14 mm	DRAIN HOSE Metric FORD 14 mm	TUBO DI SCARICO FORD 14 mm	1

V8 BLOQUE GRANDE / BIG BLOCK / BLOCCO GRANDE 7.4L & 8.2L

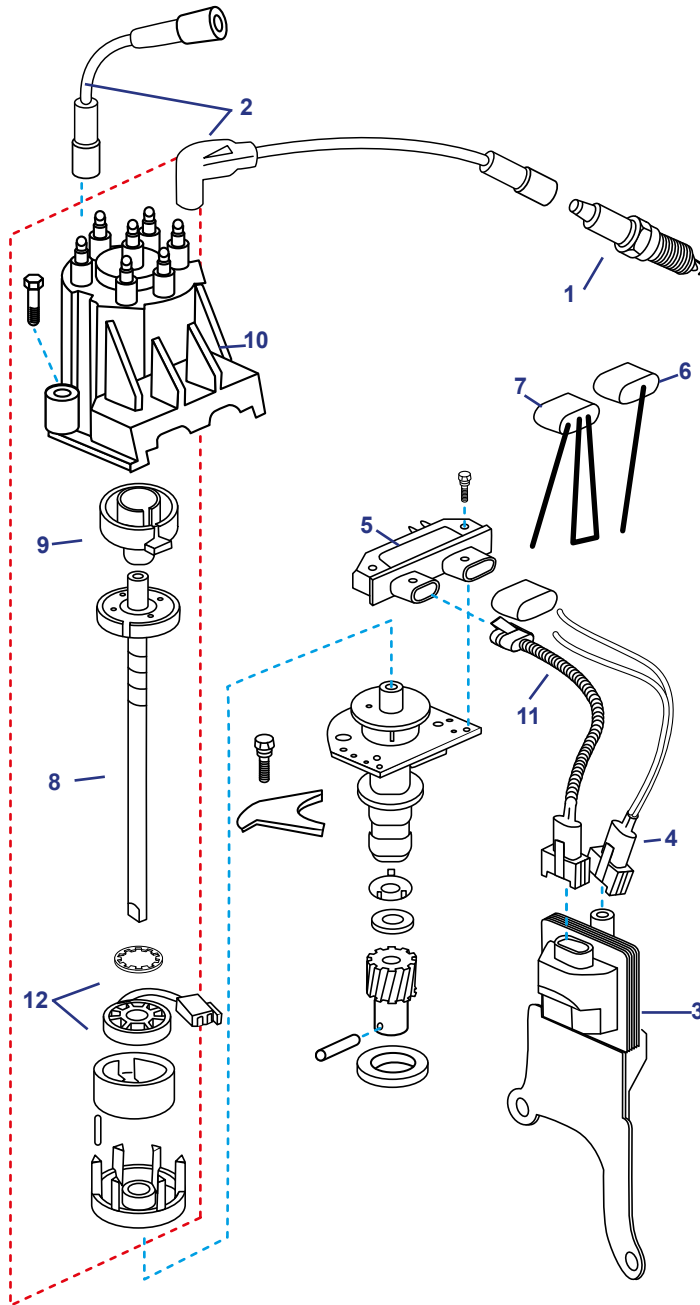

Para otros modelos consultar:  
For other models see:  
Per altri modelli vedi:



Nº	R.O. / OEM VOLVO	R.O. / OEM MERCURUISER	Ref.	Descripción	Description	Descrizione	Cantidad Quantity Quantità
1	3854002	898253T27		BUJÍAS: V8	SPARK PLUG: V8	CANDELE: V8	8
2	3854084	84-817376T01		KIT CABLES ARRANQUE: V8	IGNITION WIRE SET: V8	KIT CAVI ACCENSIONE: V8	1
3	3854003	811637001	REC3854002	BOBINA ARRANQUE	COIL: IGNITION	BOBINA ACCENSIONE	1
4			REC500442	CABLE: BOBINA	WIRE LEAD: COIL HARNESS	CAVO: BOBINA	1
5		91-888863	REC3854003	MÓDULO DISTRIBUIDOR	MODULE: DISTRIBUTOR	MODULO: DISTRIBUZIONE	1
6	3857449	805222A1	REC294005	CABLE: INTERRUPTOR	WIRE: SHIFT INTERRUPTER	CAVO: INTERRUPTORE	1
7			REC91-888863	HERRAMIENTA DISTRIBUIDOR	TOOL: TIMING	STRUMENTO: DISTRIBUZIONE	1
8	3862014	8M6001253	REC805222A1	DISTRIBUIDOR: DELCO V8 E.I. (5, 9 y 10 incluidos)	DISTRIBUTOR: DELCO V8 E.I. (5, 9 & 10 Included)	DISTRIBUZIONE: DELCO V8 E.I. (5, 9 e 10 compresi)	1
9	3854084		REC3854549	ROTOR: DISTRIBUIDOR	ROTOR: DISTRIBUTOR	ROTORE: DISTRIBUZIONE	1
10			REC3854548	TAPÓN: DISTRIBUIDOR	CAP: DISTRIBUTOR	TAPPO DISTRIBUZIONE	1
11			REC84-817376T01	CABLE: DISTRIBUIDOR - BOBINA	WIRE LEAD: DISTRIBUTOR - COIL	CAVI: DISTRIBUZIONE - BOBINA	1
12	3854001	811639T	REC3854001	MÓDULO	MODULE	MODULO	1

# BLOQUE MOTOR FORD 302/5.0L Y 351/5.8L ENGINE BLOCK FORD 302/5.0L & 351/5.8L BLOCCO MOTORE FORD 302/5.0L E 351/5.8L

FORD 302 - OMC 175 - 190 - MERCURUISER 888 - 215 - 225 - VOLVO AQ 190A  
FORD 351 - OMC 235 - 240 - 250 - MERCURUISER 233 - 255 - VOLVO AQ 240A

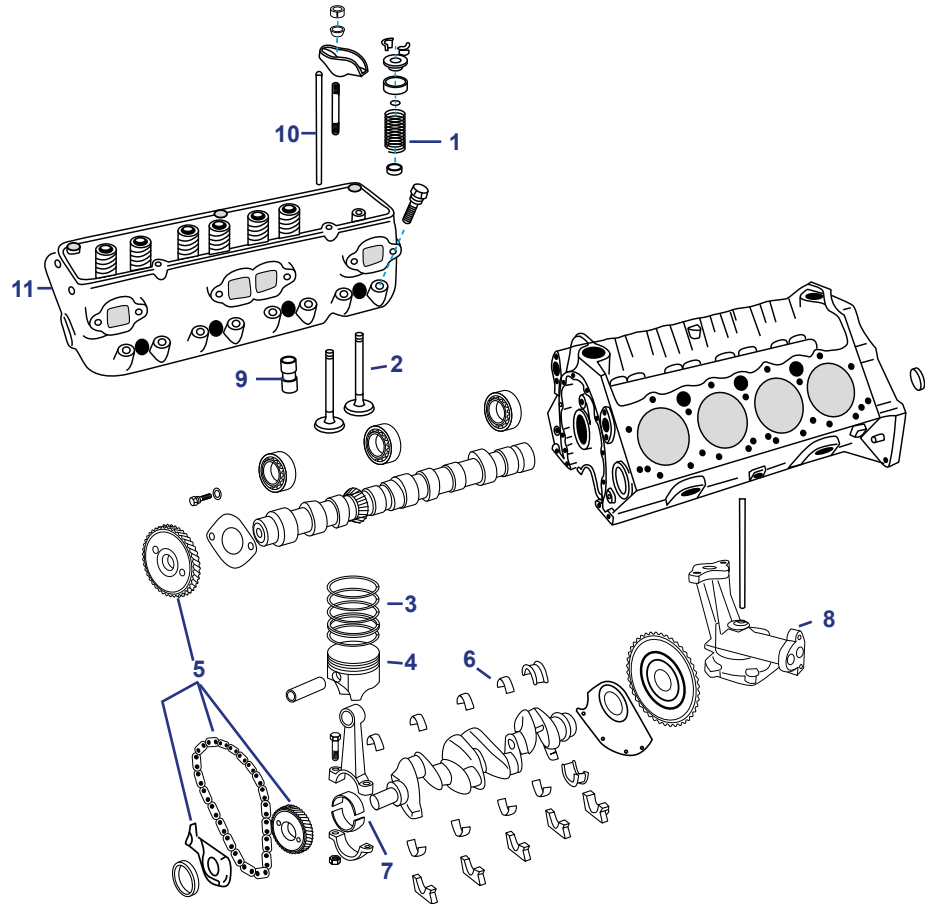

Nº	R.O. / OEM VOLVO	R.O. / OEM MERCURUISER	Ref.	Descripción	Description	Descrizione
1		24-56159	<b>REC24-56159</b>	MUELLE ADMISIÓN 5.0	INTAKE SPRING 5.0	MOLLA ASPIRAZIONE 5.0
1		24-75619	<b>REC24-75619</b>	MUELLE ESCAPE 5.0	EXHAUST SPRING 5.0	MOLLA SCARICO 5.0
1			<b>REC24-56159</b>	MUELLE ADMISIÓN 5.8	INTAKE SPRING 5.8	MOLLA ASPIRAZIONE 5.8
1			<b>REC24-75619</b>	MUELLE ESCAPE 5.8	EXHAUST SPRING 5.8	MOLLA SCARICO 5.8
2		56154	<b>REC3853731</b>	VALVULA DE ESCAPE 5.0	EXHAUST VALVE 5.0	VALVOLA SCARICO 5.0
2	3852808	56157	<b>REC3852808</b>	VALVULA DE ADMISIÓN 5.0	INTAKE VALVE 5.0	VALVOLA ASPIRAZIONE 5.0
2	3853731	56154	<b>REC3853731</b>	VALVULA DE ESCAPE 5.8	EXHAUST VALVE 5.8	VALVOLA SCARICO 5.8
2		56157	<b>REC3852808</b>	VALVULA ADMISIÓN 5.8	INTAKE VALVE 5.8	VALVOLA ASPIRAZIONE 5.8
3	3853268	39-56114	<b>REC3853268</b>	AROS PISTÓN 5.0 y 5.8	PISTON RINGS 5.0 & 5.8	ANELLO PISTONE 5.0 e 5.8
3			<b>FEDE-251K030</b>	AROS PISTÓN A 030	PISTON RINGS 030	ANELLO PISTONE 030
3	3853885		<b>REC3853885</b>	AROS PISTÓN A 040 (1995-00)	PISTON RINGS 040 (1995-00)	ANELLO PISTONE 040 (1995-00)
4			<b>FED517P</b>	PISTON 5.0 (1987+)	PISTON 5.0 (1987+)	PISTONE 5.0 (1987+)
4	3857022		<b>REC3857022</b>	PISTÓN 5.0 A 030 (1987+)	PISTON 5.0 030 (1987+)	PISTONE 5.0 030 (1987+)
4	3853898		<b>REC3853898</b>	PISTÓN 5.8 (1977+)	PISTON 5.8 (-1977)	PISTONE 5.8 (-1977)
4			<b>FED463P030</b>	PISTÓN 5.8 A 030 (1977+)	PISTON 5.8 030 (-1977)	PISTONE 5.8 030 (-1977)
4	3853898		<b>REC3853898</b>	PISTÓN 5.0 (1977+)	PISTON 5.0 (1977+)	PISTONE 5.0 (1977+)
4			<b>FED463P030</b>	PISTÓN 5.0 - 030 (1977+)	PISTON 5.0 030 (1977+)	PISTONE 5.0 030 (1977)
4	3857023		<b>REC3857023</b>	PISTÓN 5.0 - 040 (1995-00)	PISTON 5.0 040 (1995-00)	PISTONE 5.0 040 (1995-00)
5			<b>FEDKT3163SA1</b>	KIT DISTRIBUCIÓN 5.0 (1987+)	TIMING KIT 5.0 (1987+)	KIT DISTRIBUZIONE 5.0 (1987+)
5			<b>FEDKT3358SA</b>	KIT DISTRIBUCIÓN 5.0 (-1986)	TIMING KIT 5.0 (-1986)	KIT DISTRIBUZIONE 5.0 (-1986)
5			<b>FEDKT3163SA1</b>	KIT DISTRIBUCIÓN 5.8 (1988+)	TIMING KIT 5.8 (1988+)	KIT DISTRIBUZIONE 5.8 (1988+)
5			<b>FEDKT3358SA</b>	KIT DISTRIBUCIÓN 5.8 (-1986)	TIMING KIT 5.8 (-1986)	KIT DISTRIBUZIONE 5.8 (-1986)
6			<b>FED4125M</b>	KIT COJINETES BANCADA 5.0	MAIN BEARING SET 5.0	KIT CUSCINETTO PRINCIPALE 5.0

Nº	R.O. / OEM VOLVO	R.O. / OEM MERCURUISER	Ref.	Descripción	Description	Descrizione
6			FED5078M	KIT COJINETES BANCADA 5.8	MAIN BEARING SET 5.8	KIT CUSCINETTO PRINCIPALE 5.8
6			FED4125M010	KIT COJINETES BANCADA 5.0 - 010	MAIN BEARING SET 5.0 - 010	KIT CUSCINETTO 5.0 -010
7	3852775	23-56116	FED2600CP	COJINETES BIELA 5.0	BEARING ROD 5.0	CUSCINETTO BIELLA 5.0
7		23-85744	FED3380CPA	COJINETES BIELA 5.8	BEARING ROD 5.8	CUSCINETTO BIELLA 5.8
8	3853909	56174	REC3853909	BOMBA ACEITE 5.0	OIL PUMP 5.0	POMPA OLIO 5.0
8	3853908	64787	REC3850908	BOMBA DE ACEITE 5.8	OIL PUMP 5.8	POMPA OLIO 5.8
9	3853847		REC3853847	LIFTER 5.0, 5.8 y 460	LIFTER 5.0, 5.8 & 460	LIFTER 5.0, 5.8 e 460
9	3853847		REC3853847	LIFTER 5.0, 5.8 (1992-01)	LIFTER 5.0, 5.8 (1992-01)	LIFTER 5.0, 5.8 (1992-01)
10			FEDRP-3167	VARILLA ÉMBOLO 5.0 (174,5)	PUSH ROAD 5.0 (174,5)	ASTA DI BIELLA 5.0 (174,5)
10			FEDRP-3241	VARILLA ÉMBOLO 5.0 (158,75)	PUSH ROAD 5.0 (158,75)	ASTA DI BIELLA 5.0 (158,75)
10			FEDVRP-3166	VARILLA ÉMBOLO 5.8 (174,5)	PUSH ROAD 5.8 (174,5)	ASTA DI BIELLA 5.8 (174,5)
11			 CULATA	CYLINDER HEAD	TESTATA	

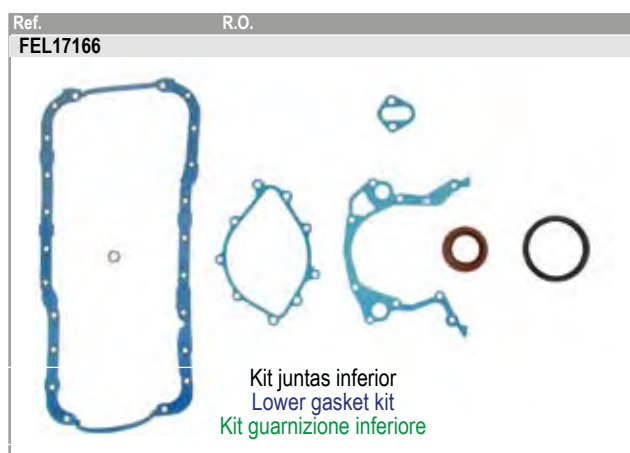
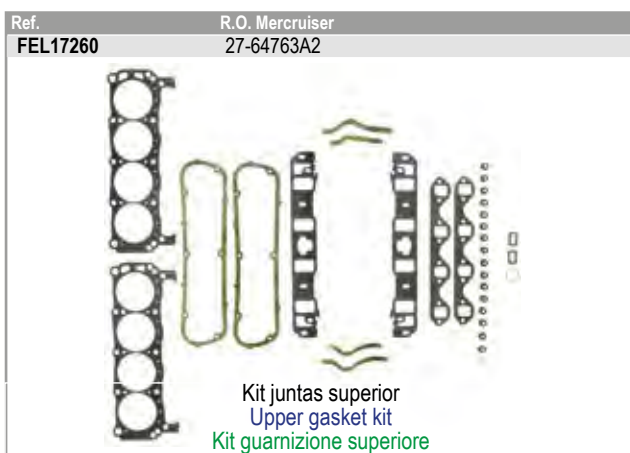

5.0L			5.8L			Descripción	Description	Descrizione
R.O. / OEM VOLVO	R.O. / OEM MERCURUISER	Ref.	R.O. / OEM VOLVO	R.O. / OEM MERCURUISER	Ref.			
3853732	27-75647	FEL17060	3853732	27-75647	FEL17060	JUNTA CULATA	HEAD GASKET	GUARNIZIONE TESTATA
	27-64763A2	FEL17260		27-64763A2	FEL17260	KIT JUNTAS SUPERIOR	UPPER GASKET SET	KIT GUARNIZIONE SUPERIORE
		FEL17261			FEL17261	KIT JUNTAS CON TAPA VALVULAS ALUMINIO	GASKET SET ALUMINUM VALVE COVER	KIT GUARNIZIONE CON COPERCHIO VALVOLA ALLUMINIO
		FEL17161			FEL17166	KIT JUNTAS INFERIOR (1 Junta cárter, 1 retén trasero)	LOWER GASKET SET (1 oil pan gasket, 1 piece rear seal)	KIT GUARNIZIONE INFERIOR (1 guarnizione coppa olio, 1 tenuta posteriore)
		FEL17160			FEL17165	KIT JUNTAS INFERIOR (4 Juntas cárter, retén trasero de 2 piezas)	LOWER GASKET SET (4 oil pan gaskets, 2 pieces rear seal)	KIT GUARNIZIONE INFERIORE (4 guarnizione coppa olio, 1 tenuta posteriore 2 pezzi)
3853912	27-73042	FEL17360	3853912	27-73042	FEL17360	KIT JUNTAS COLECTOR ADMISION	INTAKE MANIFOLD GASKET SET	KIT GUARNIZIONE COLLETTORE ASPIRAZIONE
3853742	27-73866	FEL17460	3853742	27-73866	FEL17460	KIT JUNTAS COLECTOR ESCAPE	EXHAUST MANIFOLD GASKET SET	KIT GUARNIZIONE COLLETTORE SCARICO
3852822		FEL17997	3852823		FEL17998	JUNTA CÁRTER (1pieza)	OIL PAN GASKET (1 piece)	GUARNIZIONE COPPA OLIO (1 pezzo)
	27-64798	FEL17995		27-75483	FEL17996	JUNTA CÁRTER (4 piezas)	OIL PAN GASKET (4 pieces)	GUARNIZIONE COPPA OLIO (4 pezzi)
	27-56173	FEL17945		27-56173	FEL17945	KIT JUNTAS TAPA VALVULAS	VALVE COVER GASKET SET	KIT GUARNIZIONE COPERCHIO VALVOLA
3852818		FEL17946	3852818		FEL17946	KIT JUNTAS TAPA VALVULAS ALUMINIO	ALUMINUM VALVE COVER GASKET SET	KIT GUARNIZIONE COPERCHIO VALVOLA ALLUMINIO
	26-56869	FEL17746		26-64797	FEL17748	RETÉN TRASERO CIGÜENAL CONTRARROTACIÓN	CRANKSHAFT REAR SEAL OPPOSITE ROTATION	TENUTA POSTERIORE ALBERO MOTORE Controrrotante
	26-56867	FEL17795		26-56867	FEL17795	RETÉN TAPA DISTRIBUIDOR	DISTRIBUTOR CAP SEAL	TENUTA COPERCHIO DISTRIBUZIONE

# ÍNDICE

<b>GUÍA DE IDENTIFICACIÓN DE MODELOS</b>	<b>72</b>
<b>SISTEMA ALIMENTACIÓN Y FILTRACIÓN</b>	<b>PÁG</b>
<b>BOMBAS DE COMBUSTIBLE ELÉCTRICAS Y KITS</b>	<b>217</b>
<b>BOMBAS DE COMBUSTIBLES MECÁNICAS</b>	<b>219</b>
• JUNTAS	220
• GUÍA BOMBAS MECÁNICAS	220
<b>CARBURADORES</b>	<b>202</b>
• REMANUFACTURADOS	202
• NUEVOS	203
• BOYAS	205
• GUÍA CARBURADOR	208
• GUÍA KITS CARBURADOR Y BOYAS	209
• KITS AGUJAS	205
• JUNTAS Y KITS CARBURADOR	205
• CHOKE	210
• APAGALLAMAS	211
<b>INYECTORES</b>	<b>211</b>
• KITS RETENES	211
<b>FILTROS MOTORES DE GASOLINA</b>	<b>140</b>
• FILTRO COMBUSTIBLE SEPARADOR DE AGUA	140
• BRACKETS	140
• RACORS	141
• FILTROS DECANTADORES	141
• FILTROS DE GASOLINA	142
• FILTROS AIRE	143
• FILTROS DE ACEITE	143
<b>FILTROS MOTORES DE DIESEL</b>	<b>143</b>
• FILTROS DIESEL	143
• FILTROS CON CAZOLETA Y ELEMENTOS	144
• FILTROS DECANTADORES DE DIESEL	145
• FILTROS ACEITE	146
• FILTROS DE AIRE	147
• FILTROS TIPO SEPAR 2000	147
• RACORS	147
ACCESORIOS PARA FILTROS	148
<b>SISTEMA ELÉCTRICO</b>	<b>PÁG</b>
<b>ALTERNADORES Y REGULADORES</b>	<b>136</b>
• ALTERNADORES	136
• KIT SUSTITUCIÓN ALTERNADOR	137
• REGULADOR DE ALTERNADOR	137
<b>MOTORES TRIM Y COMPONENTES</b>	<b>137</b>
<b>MOTORES DE ARRANQUE</b>	<b>134</b>
• EXTENSOR DE SOLENOIDE PARA TERMINALES	135
<b>SENSORES</b>	<b>212</b>
• MAP	212
• PICK UP	212
• TEMPERATURA AIRE	212
• PICADO	213
• POSICIÓN GAS, ÁRBOL DE LEVAS, CIGÜENAL	213
• TEMPERATURA ENFRIADOR, AGUA	213
• TEMPERATURA Y ACEITE CON ALARMA	214
• ACEITE PARA BOMBA COMBUSTIBLE	214
• IAC	214
• PRESIÓN ACEITE, COMBUSTIBLE	214
• GUÍA DE SENSORES	215
<b>SOLENOIDES Y FUSIBLES</b>	<b>138</b>
• SOLENOIDES	138
• RELÉS	139
• FUSIBLE	139
<b>SISTEMA DE ENCENDIDO</b>	<b>PÁG</b>
BOBINAS	231
MÓDULOS IGNICIÓN	231
BUJIAS	232
CABLES PARA BUJÍA	234
<b>DISTRIBUIDOR</b>	<b>221</b>
• TAPA	221
• ROTORES	222
• TRIGGER	223
• PLATINOS	223
• CONDENSADORES	223
• KITS	224
• GUÍA KITS	225
• KITS DE CONVERSIÓN ELECTRÓNICO	226
• DESPIECES DISTRIBUIDORES	227
• DISTRIBUIDORES	230

<b>SISTEMA DE REFRIGERACIÓN</b>	<b>PÁG</b>
<b>BOMBA DE AGUA</b>	<b>132</b>
• JUNTAS DE BOMBAS	133
• KITS REPARACIÓN BOMBA AGUA	176
• DESPIECE BOMBA AGUA	179
• JUNTAS	133
IMPULSORES	175
MANGUITOS DE MOTOR	239
<b>TERMOSTATOS</b>	<b>127</b>
• CUERPO	127
• EJE VÁLVULA	128
• CASQUILLO	128
• VÁLVULA T	129
• MÓDULO DISTRIBUCIÓN DE AGUA	129
• TAPA TERMOSTATO	129
• TERMOSTATOS Y KITS	131
• JUNTAS	129
INTERCAMBIADOR DE CALOR	244
ENFRIADOR DE ACEITE	244
<b>PARTES DE MOTOR</b>	<b>PÁG</b>
SOORTE MOTOR	193
RETENES DE CIGÜENAL	91
DESPIECE (470, 485, 488, 165, 170, 180, 190HP)	92
CORREAS	235
GUÍA CORREAS SERPENTÍN MOTOR	237
<b>SISTEMA DE ESCAPE Y ADMISIÓN</b>	<b>93</b>
• DESPIECES DE COLECTORES Y CODOS	94
• COLECTORES	116
• CODOS	118
• KITS SUPLEMENTOS	121
• EXTENSORES DE ESCAPE	122
• TAPAS Y JUNTAS	123
• FUELLES DE ESCAPE	125
• PALOMILLAS DE ESCAPE	125
• COLECTORES DE ADMISIÓN	126
GUÍA RETENES ACEITE	90
GUÍA DE AROS TÓRICOS	90
RETENES DE VÁLVULAS	90
JUNTA BASE MOTOR FEL-PRO	74
JUNTAS DE DISTRIBUCIÓN	89
GUÍA MANGUITOS (EJE-GASOLINA)	243
GUÍA MANGUITOS (INTRABORDA DIESEL)	244
<b>UNIDADES DE TRANSMISIÓN</b>	<b>PÁG</b>
ÁNODOS	180
COLAS	149
GUÍA MANGUITOS COLA	241
DESPIECE COLAS	152
<b>TRANSOM</b>	<b>184</b>
• DESPIECES	184
• KITS DE JUNTAS	193
• CABLE DE CAMBIO	193
• ACOPLAMIENTO DE MOTOR	194
• SILENBLOCKS	194
• FUELLES TRANSOM	195
• FUELLES CABLE DE CAMBIO	195
• MANGUITOS Y PROTECTORES DE ESCAPE	195
• KITS BOTELLAS DE ACEITE	244
COMPONENTES CAMBIO	196
<b>BRAZOS POWER TRIM Y MANGUERAS HIDRÁULICAS</b>	<b>197</b>
• DESPIECES TRIM	197
• LATIGUILLOS	201
HÉLICES Y GUÍA DE APLICACIÓN	250
HERRAMIENTAS	172
<b>GUÍA DE MANTENIMIENTO MOTORES</b>	<b>245</b>
<b>GUÍA DE MANTENIMIENTO TRANSMISIONES</b>	<b>249</b>
<b>ÍNDICE REF</b>	<b>254</b>

# TABLE OF CONTENTS

<b>MODEL IDENTIFICATION CHART</b>	<b>72</b>
<b>FUEL &amp; FILTRATION SYSTEM</b>	<b>PÁG</b>
<b>ELECTRIC FUEL PUMP &amp; KIT</b>	<b>217</b>
<b>MECHANIC FUEL PUMP</b>	<b>219</b>
• GASKETS	220
• MECHANIC PUMPS APPLICATION	220
<b>CARBURETOR</b>	<b>202</b>
• REBUILT CARBURETORS	202
• NEW CARBURETORS	203
• FLOATS	205
• CARBURETOR GUIDE	208
• CARBURETOR REPAIR KITS & FLOAT APPLICATION	209
• INLET NEEDLE KIT	205
• CARBURETORS GASKETS & KITS	205
• CHOKE	210
• FLAME ARRESTORS	211
<b>INJECTORS</b>	<b>211</b>
• FUEL INJECTOR SEAL KIT	211
<b>FILTERS GAS ENGINES</b>	<b>140</b>
• WATER SEPARATING FUEL FILTER	140
• BRACKETS	140
• RACORDS	141
• COMPLETE FUEL FILTERS	141
• FUEL FILTERS	142
• AIR FILTERS	143
• OIL FILTERS	143
<b>FILTERS DIESEL ENGINES</b>	<b>143</b>
• DIESEL FILTERS	143
• BOWL FILTERS & ELEMENTS	144
• COMPLETE DIESEL FILTERS	145
• OIL FILTERS	146
• FILTERS TYPE SEPAR 2000	146
• RACORS	147
FILTERS ACCESSORIES	148
<b>ELECTRIC SYSTEM</b>	<b>PÁG</b>
<b>ALTERNATORS, VOLTAGE REGULATORS &amp; TRIM</b>	<b>136</b>
• ALTERNATORS	136
• ALTERNATOR CONVERSION KIT	137
• VOLTAGE REGULATOR	137
<b>TRIM ENGINES</b>	<b>137</b>
<b>STARTERS</b>	<b>134</b>
• SOLENOID EXTENSOR FOR TERMINALS	135
<b>SENDERS</b>	<b>212</b>
• MAP	212
• PICK UP	212
• AIR TEMPERATURE	212
• KNOCK	213
• THROTTLE POSITION, CAMSHAFT POSITION, CRANKSHAFT POSITION	213
• COOLANT TEMPERATURE & WATER	213
• TEMPERATURA & OIL PRESSURE WARNING KIT	214
• ELECTRIC FUEL PUMP SWITC	214
• IAC	214
• OL PRESSURE	214
<b>SOLENOID &amp; FUSES</b>	<b>138</b>
• SOLENOID	138
• RELAY	139
• FUSES	139
<b>IGNITION SYSTEM</b>	<b>PÁG</b>
COILS	231
IGNITION MODULES	231
SPARK PLUGS	232
SPARK PLUGS WIRES	234
<b>DISTRIBUTOR</b>	<b>221</b>
• CAPS	221
• ROTORS	222
• TRIGGERS	223
• POINTS	223
• CONDENSERS	223
• TUNE UP KITS	224
• IGNITION APPLICATION GUIDE	225
• ELECTRONIC CONVERSION KITS	226
• DISTRIBUTORS PARTS	227
• DISTRIBUTORS	230

# INDICE

<b>COOLING SYSTEM</b>	<b>PÁG</b>	<b>GUIDA DI IDENTIFICAZIONE MODELLO</b>	<b>72</b>	<b>SISTEMA DI REFREDDAMENTO</b>	<b>PÁG</b>
<b>WATER PUMP</b>	132	<b>SISTEMA ALIMENTAZIONE E FILTRAZIONE</b>	<b>PÁG</b>	<b>POMPA ACQUA</b>	132
• GASKETS	133	<b>POMPE COMBUSTIBILE ELETTRICA E KIT</b>	<b>217</b>	• GUARNIZIONE POMPE	133
• WATER PUMP SERVICE KITS	176	<b>POMPE COMBUSTIBILE MECCANICHE</b>	<b>219</b>	• KIT RICAMBI POMPA	176
• WATER PUMP ASSEMBLY	179	• GUARNIZIONE	220	• PARTI POMPA	179
• GASKETS	133	• GUIDA POMPE MECCANICHE	220	• GUARNIZIONI	133
<b>IMPELLERS</b>	175	<b>CARBURATORE</b>	<b>202</b>	GIRANTI	175
<b>HOSES</b>	239	• RIGENERATI	202	<b>TUBI</b>	239
<b>THERMOSTAT</b>	127	• NUOVO	203	<b>TERMOSTATI</b>	127
• HOUSING	127	• GALLEGGIANTI	205	• CORPO	127
• CHECK BALL KIT	128	• GUIDA KIT CARBURATORE E GALLEGGIANTI	209	• ALBERINO TERMOSTATO	128
• THERMOSTAT SLEEVE	128	• KIT SPILLO	205	• BOCCOLA	128
• TEE VALVE ASSEMBLY	129	• GUARNIZIONE E KIT CARBURATORE	205	• VALVOLA T	129
• WATER DISTRIBUTION MODULE	129	• CHOKE	210	• MODULO DISTRIBUZIONE ACQUA	129
• COVER	129	• PARAFIAMA	211	• COPERCHIO TERMOSTATO	129
• THERMOSTATS & KITS	131	<b>INIETTORI</b>	<b>211</b>	• TERMOSTATI E KIT	131
• GASKETS	129	• KIT PARAOLI	211	• GUARNIZIONE	129
<b>HEAT EXCHANGERS</b>	244	<b>FILTRI MOTORI BENZINA</b>	<b>140</b>	SCAMBIATORI DI CALORE	244
<b>OIL COOLER</b>	244	• FILTRO SEPARATORE ACQUA-BENZINA	140	REFRIGERATORE DELL'OLIO	244
<b>ENGINE PARTS</b>	<b>PÁG</b>	• SUPPORTO	140	<b>PARTI DEL MOTORE</b>	<b>PÁG</b>
<b>ENGINE MOUNT SCREW</b>	193	• RACCORDI	140	SUPPORTI MOTORE	193
<b>CRANKSHAFT OIL SEAL</b>	91	• FILTRI DECANTATORE BENZINA	141	PARAOLIO ALBERO MOTORE	91
<b>PARTS (470, 485, 488, 165, 170, 180, 190 HP)</b>	92	• FILTRI BENZINA	142	<b>PARTE (47, 485,488,165,170,180,190HP)</b>	92
<b>BELTS</b>	235	• FILTRI ARIA	143	CINGHIE	235
<b>SERPENTINE BELTS GUIDE</b>	237	• FILTRI OLIO	143	GUIDA CINGHIE SERPENTINA	237
<b>INTAKE &amp; EXHAUST SYSTEM</b>	<b>93</b>	<b>FILTRI MOTORI DIESEL</b>	<b>143</b>	<b>SISTEMA SCARICO E ASPIRAZIONE</b>	<b>93</b>
• MANIFOLDS & ELBOWS PARTS	94	• FILTRI DIESEL	143	• PARTE COLLETTORE E GOMITO	94
• MANIFOLDS	116	• FILTRI CON COPPA E ELEMENTI	144	• COLLETTORE	116
• ELBOWS	118	• FILTRI DECANTATORE DIESEL	145	• GOMITO	118
• RISER KITS	121	• FILTRI OLIO	146	• KIT DISTANZIALI	121
• EXHAUST EXTENSOS	122	• FILTRI ARIA	147	• SCARICO ESTENSORE	122
• CAPS & GASKETS	123	• FILTRI TIPO SEPAR 2000	147	• COPERCHIO E GUARNIZIONE	123
• EXHAUST BELLOW	125	• RACCORDI	147	• CUFFIA DI SCARICO	125
• WATER SHUTTER	125	<b>ACCESSORI PER FILTRI</b>	<b>148</b>	• FARFALLA DI SCARICO	125
• INTAKE MANIFOLD	126	<b>SISTEMA ELETTRICO</b>	<b>PÁG</b>	• COLLETTORE DI ASPIRAZIONE	126
<b>OIL SEALS GUIDE</b>	90	<b>ALTERNATORE E REGOLATORI</b>	<b>136</b>	GUIDA PARAOLIO	90
<b>O-RINGS GUIDE</b>	90	• ALTERNATORE	136	GUIDA ANELLI TENUTE	90
<b>VALVE STEM SEAL</b>	90	• KIT SOSTITUZIONE ALTERNATORE	137	PARAOLIO VALVOLE	90
<b>FEL-PRO GASKETS</b>	74	• REGOLATORE ALTERNATORE	137	<b>GUARNIZIONE BASE MOTORE FEL-PRO</b>	74
<b>TIMING GASKETS</b>	89	<b>MOTORI TRIM E COMPONENTE</b>	<b>137</b>	GUARNIZIONE DISTRIBUZIONE	89
<b>HOSES GUIDE (SHAFT - FUEL)</b>	243	<b>MOTORINO D'AVVIAMENTO</b>	<b>134</b>	GUIDA MANICOTTO (ASSE-BENZINA)	243
<b>HOSES GUIDE (INBOARD - DIESEL)</b>	244	• ESTENSORE SOLENOIDE PER TERMINALI	135	GUIDA MANICOTTO (ENTROBORDO - DIESEL)	244
<b>UNIT DRIVES &amp; COMPONENTS</b>	<b>PÁG</b>	<b>SENSORI</b>	<b>212</b>	<b>UNITÀ DI TRASMISSIONE</b>	<b>PÁG</b>
<b>ANODES</b>	180	• MAP	212	<b>ANODI</b>	180
<b>STERN DRIVES</b>	149	• PICK UP	212	<b>PIEDI</b>	149
<b>HOSES GUIDE (STERN DRIVES)</b>	241	• TEMPERATURE ARIA	212	GUIDA MANICOTTO PIEDE	241
<b>GEARCASE COMPONENTS</b>	152	• BATTITO	213	<b>PARTI PIEDI</b>	152
<b>TRANSOM</b>	<b>184</b>	• POSIZIONE FARFALLA, ASSE A CAMME E ALBERO MOTORE	213	<b>TRANSOM</b>	184
• PARTS	184	• TEMPERATURA SCAMBIATORE E ACQUA	213	• PARTE	184
• GASKETS KIT	193	• TEMPERATURA PRESSIONE DELL'OLIO CON ALLARME	214	• KIT GUARNIZIONI	193
• SHIFT CABLE ASSY	193	• IAC	214	• CAVO CAMBIO	193
• COUPLER	194	• PRESIONE L'OLIO, COMBUSTIBILE	214	• ACCOPPIAMENTO MOTORE	194
• SILENBLOCKS	194	• GUIDA SENSORI	215	• SILENBLOCKS	194
• TRANSOM U-JOINT BELLOWS	195	<b>SOLENOIDE E FUSIBILE</b>	<b>138</b>	• CUFFIE TRANSOM	195
• SHIFT CABLE BELLOW SET	195	• SOLENOIDE	138	• CUFFIA CAMBIO	195
• EXHAUST TUBE & PROTECTORS	195	• RELE	139	• TUBO E PROTEZIONE SCARICO	195
• RESERVOIR ASSEMBLIES KITS	244	• FUSIBILE	139	• KIT BOTTIBLIA OLIO	244
<b>SHIFT COMPONENTS</b>	196	<b>SISTEMA DI ACCENSIONE</b>	<b>PÁG</b>	<b>COMPONENTI CAMBIO</b>	196
<b>MODELS POWER TRIM ARMS &amp; POWER STEERING HOSES</b>	<b>197</b>	<b>BOBINE</b>	<b>231</b>	<b>PISTONI POWER TRIM E TUBI IDRAULICI</b>	<b>197</b>
• TRIM PARTS	197	<b>MODULI AVVIAMENTO</b>	<b>231</b>	• PARTE TRIM	197
• POWER TRIM HOSES	201	<b>CANDELE</b>	<b>232</b>	• TUBI POWER TRIM	201
<b>PROPELLERS &amp; APPLICATION</b>	250	<b>CAVO PER CANDELE</b>	<b>234</b>	<b>ELICHE E GUIDA</b>	250
<b>TOOLS</b>	172	<b>SPINTEROGENO</b>	<b>221</b>	<b>ATTREZZI</b>	172
<b>GUIDE MANTENANCE ENGINES</b>	<b>245</b>	• CALOTTE	221	<b>GUIDA MANUTENZIONE MOTORI</b>	<b>245</b>
<b>GUIDE MANTENANCE TRANSMISSIONS</b>	<b>249</b>	• ROTORI	222	<b>GUIDA MANUTENZIONE TRASMISSIONI</b>	<b>249</b>
<b>TABLE REF</b>	<b>254</b>	• TRIGGER	223	<b>INDICE REF</b>	<b>254</b>
		• PUNTINE	223		
		• CONDENSATORI	223		
		• KIT	224		
		• GUIDA KIT	225		
		• KIT DI CONVERSIONE ELETTRONICO	226		
		• PARTI SPINTEROGENI	227		
		• SPINTEROGENI	230		



# GUÍA DE IDENTIFICACIÓN DE MODELOS

## MODEL IDENTIFICATION CHART

### GUIDA DI IDENTIFICAZIONE MODELLO MOTORE

MODELO MODEL MODELLO	S/N	AÑO YEAR ANNO	MODELO MODEL MODELLO	S/N	AÑO YEAR ANNO
<b>SEA RAY</b>			225 (4 bbl)	3385721-4166999	1973-74
3.0L	B787205-B917529	1988	225-S (4 bbl)	3385721-4166999	1973-74
4.3L	B785483-B921276	1988	233	4173000-4902304	1975-77
4.3LX	B785981-B922330	1988	255	3258728-4175499	1971-74
5.7L	B784799-B917017	1988	<b>GM V8 283, 327, 305 &amp; 350 CID</b>		
SRX5.7L, 350 Mag	B785241-B919012	1988	190	1564539-1730903	1963-64
SRX7.4L, 454 Mag Alpha	B785149-B924857	1988	898 (2 bbl)	4762210-6218461	1977-82
SRX7.4L-H, 454 Mag Bravo	B721206-B919343	1988	898 (2 bbl)	6218462-B525981	1983-84
<b>STERN DRIVES</b>			200/5.0L (2 bbl)	6218462-F600999	1985-95
SRX7.4L, Alpha	B803866-C348032	1988	5.0L (2 bbl)	L015751+	1998+
SRX7.4L-H, Bravo	B803872-B999972	1988	5.0L EFI	L012052-L340000	1998-99
<b>INBOARD ENGINES</b>			228 (4 bbl)	4765100-5170008	1977-78
5.7L	B788204-B919356	1988	228 (4 bbl)	5170009-6218461	1979-82
7.4L	B788179-B913769	1988	228 (4 bbl)	6218462-B525981	1982-84
<b>RENAULT 4 CYL. (STERN DRIVE)</b>			230 (4 bbl)	6218462-B525981	1985-86
60	1887079-5049044	1965-68	230/5.0LX (4 bbl)	B525982-F600999	1987-95
80	2049045-2851423	1966-69	225	1539620-2694014	1963-69
90	2851424-3226957	1970-72	250	2314301-2639854	1968-69
<b>GM 4 CYL. (STERN DRIVE)</b>			255	417550-4767999	1975-76
110	1537370-2044033	1963-66	250	4768000-4908849	1977
120	1666601-3377340	1964-72	260/5.7L	4908850-6218461	1978-82
120	3377341-3770649	1972-73	260/5.7L	621462-B525981	1982-86
120	3770650-4952700	1974-77	260/5.7L	B525982-F600999	1987-95
120	4952701-5192048	1978	5.7L (2 bbl)	F601000+	1996-98
120	5192049-6229717	1979-82	5.7L EFI	F225560+	1995+
120	6229718-6853913	1983-84	5.7LX (4 bbl)	F601000-K999999	1996-97
120	6853914-B531853	1985-86	5.7LX EFI	F752400-K999999	1996-97
120/2.5L	B531854-C853255	1987-89	5.7LX Bravo EFI	F800300-K999999	1996-97
140	2508261-6229717	1968-82	350 Mag Alpha	A635178-B525981	1986-87
140/3.0L	6229718-C856558	1982-89	350 Mag Alpha	B525982-F600999	1987-95
3.0L/LX	C856559+	1990+	350 Mag Alpha	F601000-K001526	1996
<b>MERCURY MARINE 4 CYL. (STERN DRIVE)</b>			350 Mag Alpha	K001527-K999999	1997
470 (2 bbl)	4208730-5520114	1976-79	350 Mag Alpha EFI	F800300-K999999	1996-97
470 (2 bbl)	5520115-6218036	1980-82	350 Mag Bravo MPI	F415189-K999999	1995-97
470 (2 bbl)	6218037-6916778	1983-84	350 Mag Bravo MPI (GEN+)	F602000-K999999	1996-97
170 (2 bbl)	6916779+	1985-86	350 Mag MPI (GEN+)	L010019+	1998+
165/3.7L (2 bbl)	6916779+	1987-89	270	2851074-3385720	1969-72
485 (2 bbl)	5685394-6218036	1980-82	280TRS	4176250-4770199	1975-76
488 (4 bbl)	6170297-6916778	1983-84	300 Tempest	6668677-B430367	1985-86
190 (4 bbl)	6916779+	1985-86	320 EFI	A543604-C622418	1987-89
180/3.7LX (4 bbl)	6916779+	1987-89	<b>GM V8 427, 454, 502, 540 &amp; 572 (STERN DRIVE)</b>		
<b>GM INLINE 6 CYL. (STERN DRIVE)</b>			325	2278747-3780449	1969-72
140	1538930-1725960	1963	330	4623115-6083144	1977-81
150	1666495-2048046	1964-66	330	6083145-B816450	1982-87
160	2048022-2770031	1967-69	7.4L Bravo	B771113-D603117	1988-91
165	2770032-5178958	1970-78	7.4L Bravo (GEN V)	D603118-F800699	1992-96
165	5178959-5813433	1979-81	7.4L Bravo (GEN VI)	F800700-K999999	1996-97
200	2453769-2712072	1969	7.4LX Bravo (MPI) (GEN V)	F602010-F801999	1996
<b>GM V6 (STERN DRIVE)</b>			7.4LX Bravo (MPI) (GEN VI)	F802000-K999999	1996-97
185 (4 bbl)	6330183-6919655	1983-84	7.4L MPI (GEN VI)	L010003+	1998
185 (2 bbl)	A331455-B527954	1985-87	7.4LX Bravo (TBI) (GEN VI)	F820000-K999999	1996-97
175/4.3L (2 bbl)	B527955-D714106	1987-92	454 Mag Alpha	A631894+	1986-88
4.3L (GEN II) (2 bbl)	D714107-F000877	1992-93	454 Mag Bravo (GEN V)	D805069-F304999	1992-94
4.3L (GEN II) (2 bbl)	F000878-F601126	1993-95	454 Mag Bravo (GEN V)	F305000-F801699	1995-96
4.3L (GEN II) (2 bbl)	F601127-F000878	1996	454 Mag Bravo (GEN VI)	F801700-K999999	1996-97
4.3LX (GEN+) (2 bbl)	F803000-K999999	1996-97	454 EFI (GEN V)	F115700-F802349	1994-96
4.3L (GEN+) (2 bbl)	L010044+	1998+	454 Mag MPI (GEN VI)	F802350-K999999	1996-97
4.3L EFI (GEN+) (TBI)	L012009+	1998+	454 Mag MPI (GEN VI)	L010029-L085399	1998
205 (4 bbl)	A331455-B527954	1985-87	454 Mag MPI (GEN VI)	L085400+	1999+
205/4.3LX (4 bbl)	B527955-D714369	1987-91	370 TRS	4179554-6721527	1978-85
4.3LX (GENII) (4 bbl)	D714370-F001219	1992-93	370 TRS	6721528-B714586	1985-87
4.3LX (GENIII) (4 bbl)	F001220-F601126	1993-95	400 TRS	4179554-B457644	1980-86
4.3LX (GENII) (4 bbl)	F601127-F802999	1996	420	A398941-D937011	1987-89
4.3LXH (GEN+) (4 bbl)	F803114+	1996-97	425	A398941-D937011	1990-93
4.3LH (GEN+) (4 bbl)	L010044+	1998	440 TRS	4179554-B485220	1983-86
262 Mag (TBI) (GEN+)	F803800-K999999	1996-97	450 (GEN V)	F347100-F347277	1995-96
<b>FORD V8 (STERN DRIVE)</b>			525 SC	D456000-F348963	1991-92
888 (2 bbl)	3108723-4887829	1971-77	525 SC (GEN V)	D456000-F348963	1992-95
215 (4 bbl)	2781153-3385720	1970-72	525 SC (GEN V)	F615814-F745215	1996

MODELO MODEL MODELLO	S/N	AÑO YEAR ANNO
525 SC (GEN VI)	F745260+	1996-97
390	2781129-3042731	1969-70
460 TRS	4719554-6181046	1983-86
465	C849992-F213244	1990-92
465 (GEN V)	C849992-F213244	1992-94
500 (GEN V)	F213293-F745159	1994-96
500 (GEN VI)	F745195-L001772	1997-98
502 Mag Bravo	C878221-D824588	1990-92
502 Mag Bravo (GEN V)	D824589-F114528	1992-93
502 EFI (GEN V)	D840650-F802599	1993-96
502 Mag MPI (GEN VI)	F802600-K999999	1996-97
500 EFI	L001477+	1999+
502 Mag MPI (GEN VI)	L085433+	1998
600 SC	D456489-F877642	1991-92
600 SC (GEN V)	D456489-F877642	1992-96
600 SC (GEN VI)	K000227+	1997
500 Bulldog	C577254-F745405	1990-96
500 Bulldog	K000248+	1997
575	A677429-D763716	1986-92
800 SC (GEN V)	D763836+	1993-96
<b>MCM 4, 5, 6 &amp; V8 CYL. DIESEL (STERN DRIVE ENGINE)</b>		
Rover 60HP	31400000F+	1965-67
530 D-TA 150 HP	B993000-B993492	1989
636 D-TA 180 HP	B993500-C696047	1989
D183 140 HP	B993493-D725149	1990-93
D219 170 HP	C696048-D850124	1990-93
D254 200 HP	C849484-D554729	1990-93
D3.0L 140 HP	D725150+	1994+
D3.6L 170 HP	D850125+	1994+
D4.2L 200 HP	D554730+	1994+
D7.3L 238 HP	F060000+	1994+
<b>MERCURY MARINE MIE 4 CYL (INBOARD)</b>		
470	5520115-6218036	1980-81
<b>FORD MIE V8 (INBOARD)</b>		
215	2781153-3563181	1970-72
225	3385721-4176999	1970-72
233	4173000-4775784	1975-76
255	3258728-4178299	1973-74
<b>GM MIE V8 305, 327, 350 CID (INBOARD)</b>		
198	4762210-6218461	1977
228	4765100-5170008	1977-78
228	5170009-5907057	1978-80
230/5.0L (4 bbl)	5907058-B788151	1981-87
225	2278647-2694014	1968
250	2314301-2639854	1968-69
255	4175500-5907057	1975-80
260/5.7L	5907058-F024999	1981-93
270	2851074-3077735	1969-72
5.7L	F025000-K999999	1994-97
5.7L (GEN+)	L002003+	1998
5.7L MPI	K040300-K999999	1997
350 Mag MPI (GEN+)	L002008-L304499	1998
350 Mag MPI (GEN+)	L304500+	1999
350 Horizon	L304700+	1999+
5.7L Ski	A338533-B514626	1985-87
5.7L Competition Ski	B514627-F775199	1987-95
5.7L Competition Ski	F775200-K040003	1996
5.7L Competition Ski	K040004-K999999	1997
5.7L Competition Ski (GEN+)	L002005+	1998+
350 Mag Ski	D505454-K999999	1991-97
350 Mag EFI Ski	F215561-K999999	1994-97
350 Mag MPI Ski	F350583-F799999	1995-98
Black Scorpion Ski	F800000+	1996-98
<b>GM MIE V8 427, 454, 482 &amp; 502 CID (INBOARD)</b>		
325	2278747-3780449	1968-74
330	4623115-5889913	1977-80
340/7.4L w/B/W MK4	5889914+	1981-92
7.4L w/Hurth (LH) MK4	C391564-D715493	1989-92
7.4L (LH)	D715494-K999999	1992-97
7.4L MPI (LH)	F563050-K999999	1995-97
7.4L MPI (L29) (GEN VI)	L002006+	1998
7.4L TBI (LH) (GEN VI)	F874815-K999999	1996-97
454 Mag MPI Horizon	L002200-L086049	1998-99
454 EFI (SKI) (GEN V)	F215800-F820099	1995-96
454 Mag MPI (SKI) (GEN VI)	F820100-K999999	1996-97

MODELO MODEL MODELLO	S/N	AÑO YEAR ANNO
350	9780450-4623109	1974-76
390	2781129-2825059	1969-70
8.2L w/Hurth	C878221-D857199	1990-92
8.2L (GEN V)	D857200-F819619	1993-96
8.2L MPI (LH) (GEN VI)	F819620-K999999	1996-97
8.2L MPI (LH) (GEN VI)	L002450-L0086012	1998
8.2L MPI (LH) (GEN VI)	L0086013+	1999
<b>MIE 5, 6 &amp; V8 CYL. DIESEL INBOARD ENGINES</b>		
530 D-TA 150 HP	B993002-C539258	1989
636 D-TA 180 HP	B993750-C696011	1989
D183 150 HP	C539259-D725149	1990-93
D219 180 HP	C696012-D850124	1990-93
D254 210 HP	C849461-D554729	1990-93
D3.0L 150 HP	D725150+	1994+
D3.6L 180 HP	D850125+	1994+
D4.2L 210 HP	D554730+	1994+
D7.3L 262 HP	F060000+	1994+
<b>MC 60, 80 &amp; 90 STERN DRIVES &amp; TRANSOM PLATES</b>		
60 (O)	1830753-2063740	1965-66
80	2063741-2898029	1966-69
90	2898020-3225967	1970-72
<b>MC I, II &amp; III</b>		
I	1534570-1684187	1963
II (1.33:1)	1474909-2278488	1962-67
II (1.78:1)	2398798-2671321	1968-69
III	2373127-3002613	1968-72
III	5128065+	1978+
<b>MC 1A, 1B &amp; 1C</b>		
1A, 1B & 1C	1684188-1777798	1964
1A, 1B & 1C (E-Z Shift)	1776349-2065189	1965-66
<b>MC 120, 140, 160 &amp; 165</b>		
120/140	2062141-378049	1967-73
120/140	3780850-4893634	1974-77
120/140	4893635-6225576	1978-82
160	2065190-2763441	1967-69
165	2763442-3780849	1970-73
165	3780849-4890459	1974-77
165	4890460-6268064	1978-82
<b>MC 470 &amp; 485</b>		
470	4208730-4893830	1976-77
470	4893835-6225576	1978-82
485	5487437-6225576	1980-82
<b>MC 488, 225S &amp; 233</b>		
888	3106717-3784374	1971-73
888	3784375-4782329	1974-77
225S	3856268-4200499	1974
233	4200500-4782329	1975-77
<b>MC 898, 228, 250 &amp; 260</b>		
898/228	4782330-4898729	1977
898/228	4898730-6229157	1978-82
250	4791300-4898729	1977
260	4898730-6229157	1978-82
<b>MC R, MR, ALPHA ONE, ALPHA ONE SS &amp; ALPHA ONE GEN II</b>		
R	6152230-6847029	1983-84
MR	6810538-A479506	1985
Alpha One	A470165+	1986-90
Alpha One SS	A545004+	1986-89
Alpha One Gen II	D469859+	1991+
<b>MC BRAVO &amp; BLACKHAWK</b>		
Bravo One	B664190+	1988+
Bravo Two	C564952+	1989+
Bravo Three	D763691+	1993+
Blackhawk	F186717+	1994+
<b>MC 215E &amp; 215 H</b>		
215 H	2782203-2909034	1970
215 E	2782203-2909034	1970-72
<b>MC TR &amp; TRS</b>		
TR	3377316-3787239	1973
TR	3787240-4794899	1974-76
TR	4794900-5009866	1977
TR	5009867+	1978+
TRS	3787240-4203749	1974-75
TRS	4203750-4795399	1976
TRS	4795400+	1977+

# JUNTAS PARA BASES GM Y FORD MARINE GASKETS TO GM & FORD ENGINES GUARNIZIONI PER MOTORI GM E FORD



Los Kits FEL-PRO, están diseñados y catalogados específicamente para aplicaciones marinas. Su calidad es superior a las juntas originales.  
FEL-PRO gaskets kits are designed and cataloged specifically for marine engine applications. Their quality is even better than the oem's.  
I kit di guarnizioni FEL-PRO, sono disegnati e fabbricati specificatamente per applicazioni marine. La qualità è assolutamente paragonabile a quelle originali.

SERIE SERIAL SERIE	Descripción	Description	Descrizione
FEL17000 - FEL17099	KIT JUNTAS DE CULATA en pack individual.	CYLINDER HEAD gasket single-packed	Guarnizioni TESTATA quantità 1
FEL17100 - FEL17199	JUEGOS DE CONVERSIÓN Todas las juntas y retenes de aceite que no se encuentran en los juegos de culata y que son necesarios para completar el acoplamiento del motor (incluye las juntas del cárter y los retenes).	CONVERSION KITS All gaskets and oil seals not found in a Head Set, that are necessary for a complete engine overhaul. This includes timing cover gaskets and seals, oil pan gaskets, and rear main bearing seals.	KIT PARTE BASSA Include tutte le guarnizioni ed i paraoli della parte bassa del motore, viene fornita anche la guarnizione della coppa dell'olio.
FEL17200 - FEL17299	KIT DE DESCARBONIZACIÓN Todas las juntas y retenes necesarios para el trabajo de las válvulas, incluyendo la culata, la tapa de la válvula y juntas de colector de admisión y colector de escape. (Los juegos de 4 cyl no contienen las juntas del colector de admisión/escape. Deben pedirse por separado).	HEAD SETS SERIES All gaskets and seals necessary for a valve griding job, including cylinder head gaskets, valve cover gaskets, intake & exhaust manifold gaskets (except 4 cyl intake set), and valve stem seals.	KIT PARTE ALTA (SMERIGLIO) Include tutte le guarnizioni ed i paraoli della parte alta del motore, testate, carter distribuzione, aspirazione e scarico. (motori a 4 cyl. la guarnizione aspirazione è da ordinare separatamente).
FEL17300 - FEL17399	KIT DE COLECTOR DE ADMISIÓN Juntas de la parte de admisión del colector, retenes y juntas de la base del distribuidor.	INTAKE MANIFOLD SETS Intake manifold side gaskets, intake manifold end seals, and distributor mounting gasket.	KIT GUARNIZIONE ASPIRAZIONE Tutte le guarnizioni
FEL17400 - FEL17499	KIT DE COLECTOR DE ESCAPE (De colector a culata)	EXHAUST MANIFOLD (manifold-to-cylinder head) gaskets.	KIT GUARNIZIONE SCARICO (dalla testata al collettore)
FEL17700 - FEL17749	KIT DE CONTRARROTACIÓN RETÉN TRASERO DEL CIGÜEÑAL Retenes traseros del cigüeñal diseñados para motores de rotación opuesta a la normal. (Retenes de rotación normal incluidos en el set de conversión)	REVERSE ROTATION REAR MAIN BEARING SEAL SETS Rear main bearing seals designed to seal a crankshaft which rotates in the opposite direction from normal (Standard rotation seal is included in conversion set)	PARAOLIO MOTORI CONTROROTANTI ALBERO MOTORE Nei motori rotazione STD il paraolio viene già incluso nel kit della parte bassa.
FEL17750 - FEL17799	KIT DE RETENES TAPA DEL CIGÜEÑAL DE CONTRARROTACIÓN Retenes de la tapa del cigüeñal diseñados para motores de rotación opuesta a la normal. (Retenes de rotación normal incluidos en el set de conversión).	REVERSE ROTATION TIMING COVER SEAL SETS SERIES Timing cover seals designed to seal crankshaft which rotates in the opposite direction from normal (standard rotation seal is included in Conversion set and Timing cover set)	PARAOLIO CARTER DISTRIBUZIONE CONTROTOTANTI Modelli rotazione STD, incluso nella parte bassa.
FEL17900 - FEL17949	KIT DE TAPA VÁLVULA Todas las juntas de las tapas de las válvulas para sellar el motor.	VALVE COVER SET SERIES All valve cover or push rod cover gaskets (and grommets if required) required to seal one engine.	KIT COPERCHIO PUNTERIE Tutte le guarnizioni
FEL17950 - FEL17999	KIT DE CÁRTER Todas las juntas del cárter.	OIL PAN SETS SERIES All oil pan gaskets & seals, or one-piece molded rubber oil pan gasket, required to seal one engine.	GUARNIZIONE COPPA DELL'OLIO Tutte le guarnizioni

## 120 / 205L (120 HP)

Ref	Descripción	Description	Descrizione
	<b>CULATA</b>	<b>CYLINDER HEAD</b>	<b>TESTATA</b>
FEL17000	JUNTA CULATA	CYLINDER HEAD	GUARNIZIONE TESTATA
FEL17200	KIT JUNTAS SUPERIOR No incluye juntas colector escape/admisión	GASKET HEAD SET Intake & Exhaust manifold gasket not included	KIT PARTE ALTA Non include guarnizioni collettore scarico / aspirazione
	<b>INFERIOR</b>	<b>CONVERSION</b>	<b>PARTE BASSA</b>
FEL17100	KIT JUNTAS INFERIOR (2361802+) retén 2 piezas, 4 piezas junta cárter.	CONVERSION GASKET SET (2361802+) 2 piece rear main bearing seal & 4 piece oil pan gasket	KIT PARTE BASSA (2361802+) Paraolio in 2 px, 4 pz guarnizione coppa dell'olio.

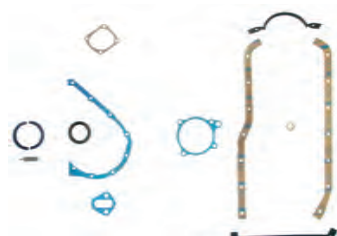
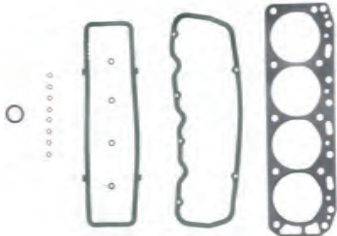

Ref	Descripción	Description	Descrizione
	<b>COLECTOR ADMISIÓN-ESCAPE</b>	<b>MANIFOLD INTAKE &amp; EXHAUST</b>	<b>ASPIRAZIONE - SCARICO</b>
FEL17300	Junta Admisión-Escape (1666601 - 6229717)	Intake-Exhaust Gasket (1666601 - 6229717)	Guarnizione aspirazione - scarico (1666601 - 6229717)
FEL17302	Junta Admisión-Escape (6229718+)	Intake-Exhaust Gasket (6229718+)	Guarnizione aspirazione - scarico (6229718+)
	<b>CARTER</b>	<b>OIL PAN</b>	<b>COPPA DELL'OLIO</b>
FEL17950	KIT JUNTAS CARTER Retén trasero dos piezas, 4 piezas junta cárter.	GASKET OIL PAN SET Two piece rear main bearing seal & 4 piece oil pan gasket	KIT GUARNIZIONE Paraolio posteriore in 2, guarnizione coppa in 4 pz.
	<b>TAPA VÁLVULAS</b>	<b>VALVE COVER</b>	<b>COPERCHIO VALVOLE</b>
FEL17900	Junta Tapa Válvulas	Gasket	Guarnizione
	<b>TAPA EMPUJADORES</b>	<b>PUSH ROD COVER</b>	<b>COPERCHIO ASTE PUNTERIE</b>
FEL17903	Junta Tapa Empujadores	Gasket Push Rod Cover	Guarnizione coperchio aste punterie

**140 / 3.0L, 140 / 3.0LX (115, 130, 135, 140 HP)**

Ref	Descripción	Description	Descrizione
	<b>CULATA</b>	<b>CYLINDER HEAD</b>	<b>TESTATA</b>
FEL17000	JUNTA CULATA	CYLINDER HEAD	GUARNIZIONE TESTATA
FEL17200	KIT JUNTAS SUPERIOR No incluye juntas colector escape/admisión	GASKET HEAD SET Intake & Exhaust manifold gasket not included	KIT PARTE ALTA Non include guarnizioni collettore scarico / aspirazione
	<b>INFERIOR</b>	<b>CONVERSION</b>	<b>PARTE BASSA</b>
FEL17102	KIT JUNTAS INFERIOR retén 1 piezas, 1 pieza junta cárter.	CONVERSION GASKET SET 1 piece rear main bearing seal & 1 piece oil pan gasket	KIT PARTE BASSA Paraolio in 1 pz, 1 pz guarnizione coppa dell'olio.
FEL17100	KIT JUNTAS INFERIOR (2361802+) retén 2 piezas, 4 piezas junta cárter.	CONVERSION GASKET SET (2361802+) 2 piece rear main bearing seal & 4 piece oil pan gasket	KIT PARTE BASSA (2361802+) Paraolio in 2 pz, 4 pz guarnizione coppa dell'olio.
	<b>COLECTOR ADMISIÓN-ESCAPE</b>	<b>MANIFOLD INTAKE &amp; EXHAUST</b>	<b>ASPIRAZIONE - SCARICO</b>
FEL17302	Junta Admisión-Escape (6229718+) excepto 3.0 LX	Intake-Exhaust Gasket (6229718+) excl. 3.0 LX	Guarnizione aspirazione - scarico (6229718+) eccetto 3.0 LX
FEL17304	Junta Admisión-Escape (6229718+) sólo 3.0 LX	Intake-Exhaust Gasket (6229718+) only 3.0 LX	Guarnizione aspirazione - scarico (6229718+) solo 3.0 LX
FEL17301	Junta Admisión-Escape (-9229717)	Intake-Exhaust Gasket (-9229717)	Guarnizione aspirazione - scarico (9229717)
	<b>CARTER</b>	<b>OIL PAN</b>	<b>COPPA DELL'OLIO</b>
FEL17950	KIT JUNTAS CARTER Retén trasero dos piezas, 4 piezas junta cárter.	GASKET OIL PAN SET Two piece rear main bearing seal & 4 piece oil pan gasket	KIT GUARNIZIONE Paraolio posteriore in 2, guarnizione coppa in 4 pz.

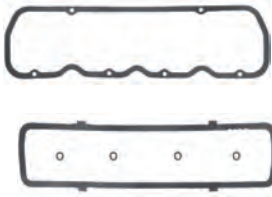

Ref	Descripción	Description	Descrizione
	<b>TAPA VÁLVULAS</b>	<b>VALVE COVER</b>	<b>COPERCHIO VALVOLE</b>
FEL17900	Junta Tapa Válvulas	Gasket	Guarnizione
	<b>TAPA EMPUJADORES</b>	<b>PUSH ROD COVER</b>	<b>COPERCHIO ASTE PUNTERIE</b>
FEL17903	Junta Tapa Empujadores	Gasket Push Rod Cover	Guarnizione coperchio aste punterie

**165, 170, 180, 190, 470, 485, 488**



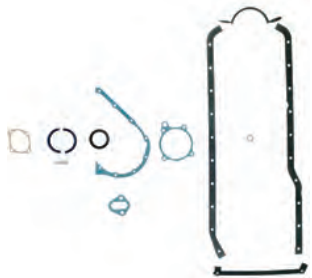
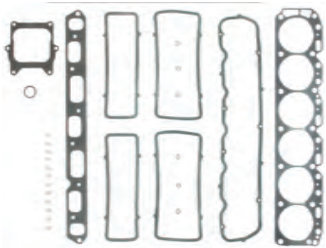

Ref	Descripción	Description	Descrizione
	<b>CULATA</b>	<b>CYLINDER HEAD</b>	<b>TESTATA</b>
FEL17069	JUNTA CULATA	CYLINDER HEAD	GUARNIZIONE TESTATA

**160 HP, 165 HP (2770032 - 6916778)**

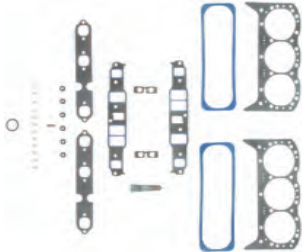
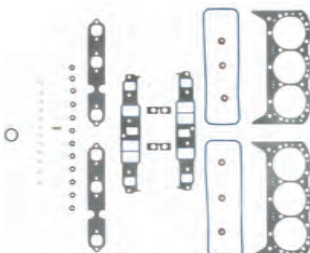
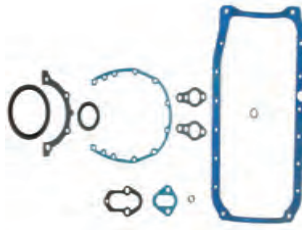
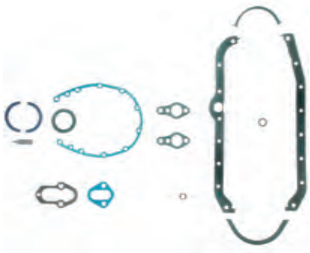
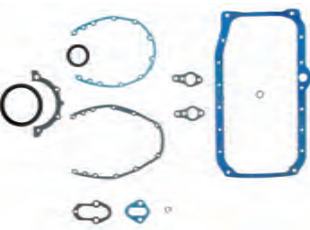
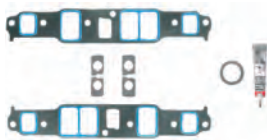

Ref	Descripción	Description	Descrizione
	<b>CULATA</b>	<b>CYLINDER HEAD</b>	<b>TESTATA</b>
FEL17019	JUNTA CULATA	CYLINDER HEAD	GUARNIZIONE TESTATA
FEL17219	KIT JUNTAS SUPERIOR No incluye juntas colector escape/admisión	GASKET HEAD SET Intake & Exhaust manifold gasket not included	KIT PARTE ALTA Non include guarnizioni collettore scarico / aspirazione
	<b>INFERIOR</b>	<b>CONVERSION</b>	<b>PARTE BASSA</b>
FEL17119	KIT JUNTAS INFERIOR Solo cárter 24 tornillos	CONVERSION GASKET SET 24 bolt oil pan only	KIT PARTE BASSA Solo coppa con 24 viti.
	<b>COLECTOR ADMISIÓN-ESCAPE</b>	<b>MANIFOLD INTAKE &amp; EXHAUST</b>	<b>ASPIRAZIONE - SCARICO</b>
FEL17319	Junta Admisión-Escape	Intake-Exhaust Gasket	Guarnizione aspirazione - scarico
	<b>CARTER</b>	<b>OIL PAN</b>	<b>COPPA DELL'OLIO</b>
FEL17975	KIT JUNTAS CARTER Solo cárter 24 tornillos	GASKET OIL PAN SET 24 bolt oil pan only	KIT GUARNIZIONE Solo coppa con 24 viti.
	<b>TAPA VÁLVULAS</b>	<b>VALVE COVER</b>	<b>COPERCHIO VALVOLE</b>
FEL17925	Junta Tapa Válvulas	Gasket	Guarnizione
	<b>TAPA EMPUJADORES</b>	<b>PUSH ROD COVER</b>	<b>COPERCHIO ASTE PUNTERIE</b>
FEL17926	Kit junta Tapa Empujadores	Gasket Push Rod Cover Set	Kit guarnizione coperchio aste punterie

**4.3L: 155, 175 HP,  
4.3LX: 175, 180, 205 HP  
175 & 185 HP 2 CUERPOS / HOUSING / CORPI BBL.,  
205 HP 4 CUERPOS / HOUSING / CORPI BBL.**

Ref	Descripción	Description	Descrizione
	<b>CULATA</b>	<b>CYLINDER HEAD</b>	<b>TESTATA</b>
 FEL17010	JUNTA CULATA Se necesitan dos	CYLINDER HEAD 2 required	GUARNIZIONE TESTATA Necessarie 2
 FEL17210	KIT JUNTAS SUPERIOR Motor sin eje equilibrado. Incluye juntas tapa válvulas y retenes.	GASKET HEAD SET Engine without balance shaft; valve cover gskts and premium valve stem seals incl.	KIT PARTE ALTA Motore senza asse bilanciato. Include guarnizione coperchio punterie e paraoli valvole.
 FEL17211	KIT JUNTAS SUPERIOR Motor con eje equilibrado. Incluye juntas tapa válvulas y retenes.	GASKET HEAD SET Engine with balance shaft; valve cover gskts and premium valve stem seals incl.	KIT PARTE ALTA Motore con asse bilanciato. Include guarnizione coperchio punterie e paraoli valvole.
	<b>INFERIOR</b>	<b>CONVERSION</b>	<b>PARTE BASSA</b>
 FEL17115	KIT JUNTAS INFERIOR Motor sin eje equilibrado con retén de una pieza y 1 pieza junta cárter incluye Junta de cárter.	CONVERSION GASKET SET Engine without balance shaft with one-piece rear main bearing seal & 1 piece oil pan gasket; oil pan gasket incl.	KIT PARTE BASSA Motore senza asse bilanciato. Paraolio post in 1 pz e guarnizione coppa in 1 pz.
 FEL17110	KIT JUNTAS INFERIOR Motor sin eje equilibrado con retén de 2 piezas y 4 piezas junta cárter incluye Junta de cárter.	CONVERSION GASKET SET Engine without balance shaft with 2 pieced rear main bearing seal & 4 pieces oil pan gasket; oil pan gasket incl.	KIT PARTE BASSA Motore senza asse bilanciato. Paraolio post in 2 pz e guarnizione coppa in 4 pz.
 FEL17116	KIT JUNTAS INFERIOR Motor con eje equilibrado con retén de 1 pieza y 1 pieza junta cárter incluye Junta de cárter.	CONVERSION GASKET SET Engine without balance shaft with one-piece rear main bearing seal & 1 piece oil pan gasket; oil pan gasket incl.	KIT PARTE BASSA Motore con asse bilanciato. Paraolio post in 1 pz e guarnizione coppa in 1 pz.
	<b>COLECTOR ADMISIÓN-ESCAPE</b>	<b>MANIFOLD INTAKE &amp; EXHAUST</b>	<b>ASPIRAZIONE - SCARICO</b>
 FEL17310	Kit Junta Admisión-Escape	Intake-Exhaust Gasket Set	Kit guarnizioni aspirazione
 REC824326002	Junta Admisión Vortec (2 unid.)	Intake Gasket Vortec (2 units)	guarnizione aspirazione Vortec (2 unità)

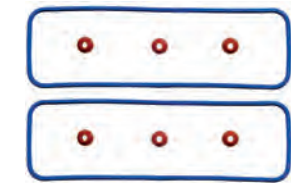
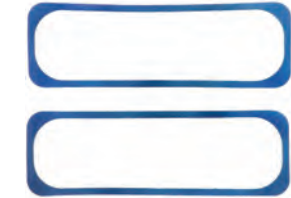
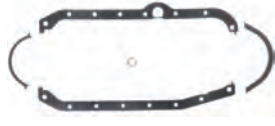
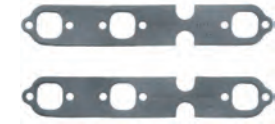

Ref	Descripción	Description	Descrizione
FEL17410	Kit juntas colector - escape	Exhaust gasket set	Kit guarnizione scarico
	<b>CARTER</b>	<b>OIL PAN</b>	<b>COPPA DELL'OLIO</b>
FEL17970	KIT JUNTAS CARTER 4 piezas junta cárter. (Retén 2 piezas)	GASKET OIL PAN SET 4 piece oil pan gasket (2 piece Seal)	KIT GUARNIZIONE Guarnizione coppa in 4 pz.
FEL17971	1 junta carter (Retén 1 pieza)	1 piece oil pan gasket (1 piece seal)	Guarnizione coppa in 1 pz (paraolio 1 pz)
REC27-142471	1 Junta Carter de goma	1 rubber oil pan gasket	Guarnizione 1 pz
	<b>TAPA VÁLVULAS</b>	<b>VALVE COVER</b>	<b>COPERCHIO VALVOLE</b>
FEL17920	KIT JUNTA TAPA VÁLVULAS Motor sin eje equilibrado.	GASKET SET Engine without balance shaft	GUARNIZIONE COPERCHIO PUNTERIE Motore senza asse equi- brato.
FEL17921	KIT JUNTA TAPA VÁLVULAS Motor con eje equilibrado.	GASKET SET Engine with balance shaft	GUARNIZIONE COPERCHIO PUNTERIE Motore con asse equilibrato.

**5.0L: 215 HP, 225 HP , 888 (198 HP)  
BASE FORD / FORD BLOCK / BASE FORD**

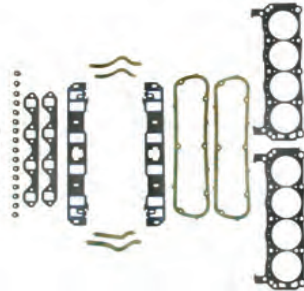

Ref	Descripción	Description	Descrizione
	<b>CULATA</b>	<b>CYLINDER HEAD</b>	<b>TESTATA</b>
FEL17060	JUNTA CULATA Se necesitan dos	CYLINDER HEAD 2 required	GUARNIZIONE TESTATA Necessarie 2
FEL17260	KIT JUNTAS SUPERIOR Incluye retenes válvulas.	GASKET HEAD SET Premium valve stem seals incl.	KIT PARTE ALTA include paraoli valvole
	<b>INFERIOR</b>	<b>CONVERSION</b>	<b>PARTE BASSA</b>
FEL17160	KIT JUNTAS INFERIOR	CONVERSION GASKET SET	KIT PARTE BASSA



Ref	Descripción	Description	Descrizione
	<b>COLECTOR ADMISIÓN-ESCAPE</b>	<b>MANIFOLD INTAKE &amp; EXHAUST</b>	<b>ASPIRAZIONE - SCARICO</b>
FEL17360	Kit Junta Admisión-Escape	Intake-Exhaust Gasket Set	Kit guarnizioni aspirazione
FEL17460	Kit juntas colector -escape	Oil pan gasket set	Kit guarnizione coppa olio
	<b>CARTER</b>	<b>OIL PAN</b>	<b>COPPA DELL'OLIO</b>
FEL17995	KIT JUNTAS CARTER (Retén 2 piezas)	GASKET OIL PAN SET (2 pieces seal)	KIT GUARNIZIONE (paraolio 2 pz)
	<b>TAPA VÁLVULAS</b>	<b>VALVE COVER</b>	<b>COPERCHIO VALVOLE</b>
FEL17945	KIT JUNTA TAPA VÁLVULAS Motor sin eje equilibrado. Juntas de goma PermaDry incluidas.	GASKET SET Engine without balance shaft, PermaDry molded rubber gaskets included.	GUARNIZIONE COPERCHIO PUNTERIE Motore senza asse equilibrato.

**5.0L: 180, 190, 200, 228, 230 HP  
5.0LX: 205, 230 HP; 198/888 (198HP)**

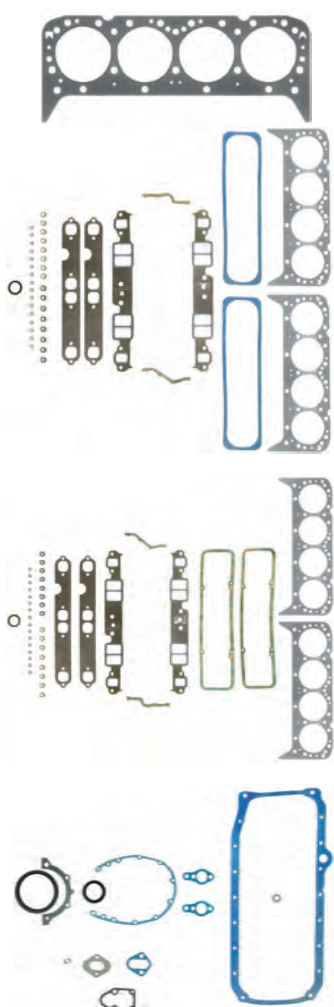

Ref	Descripción	Description	Descrizione
	<b>CULATA</b>	<b>CYLINDER HEAD</b>	<b>TESTATA</b>
FEL17020	JUNTA CULATA Se necesitan dos	CYLINDER HEAD 2 required	GUARNIZIONE TESTATA Necessarie 2
FEL17224	KIT JUNTAS SUPERIOR Tornillo centro tapa válvulas con juntas tapa válvulas. Incluye retenes válvulas.	GASKET HEAD SET w/center bolt desing valve covers; valve cover gskts; Premium valve stem seals incl.	KIT PARTE ALTA Coperchio punterie con vite nel centro, include paraoli valvole.
FEL17220	KIT JUNTAS SUPERIOR Tornillo en el canto tapa válvulas. Incluye retenes válvulas.	GASKET HEAD SET Rim bolt desing valve covers. Premium valve stem seals incl.	KIT PARTE ALTA Coperchio punterie con vite nel perimetro. Include paraoli valvole.
	<b>INFERIOR</b>	<b>CONVERSION</b>	<b>PARTE BASSA</b>
FEL17125	KIT JUNTAS INFERIOR Retén de una pieza y junta cárter de una pieza incluye. (Retén 1 pieza)	CONVERSION GASKET SET One-piece rear main bearing seal & 1 piece oil pan gasket; oil pan gasket included (1 piece seal)	KIT PARTE BASSA Paraolio in 1 pz e guarnizione coppa in 1 pz. (paraolio 1 pz)



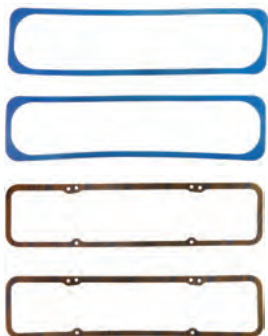
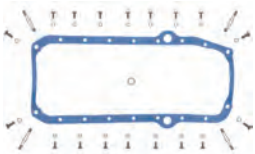
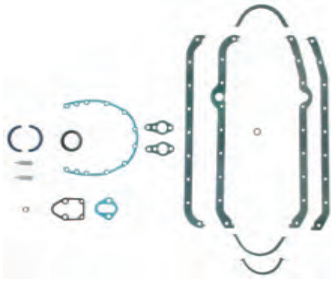

Ref	Descripción	Description	Descrizione
FEL17120	KIT JUNTAS INFERIOR Retén de dos piezas y junta cárter de 4 piezas	CONVERSION GASKET SET Two-piece rear main bearing seal & 4	KIT PARTE BASSA Paraolio in 2 pz e guarnizione coppa in 4 px.
	<b>COLECTOR ADMISIÓN-ESCAPE</b>	<b>MANIFOLD INTAKE &amp; EXHAUST</b>	<b>ASPIRAZIONE - SCARICO</b>
FEL17320	Kit Junta Admisión-Escape	Intake-Exhaust Gasket Set	Kit guarnizioni aspirazione
REC27-807473A1	Junta Admisión Vortec (2 unid.) Junta de plástico.	Intake Gasket Vortec (2 units) Gasket in plastic.	Guarnizione Vortec necessita 2 pz guarnizione in plastica
FEL17420	Kit juntas colector -escape	Oil pan gasket set	Kit guarnizione scarico
	<b>CARTER</b>	<b>OIL PAN</b>	<b>COPPA DELL'OLIO</b>
FEL17982	1 pieza junta cárter incluye Junta de cárter.	1 piece oil pan gasket. PermaDry molded rubber oil pan gasket included	guarnizione in 1 pz.
FEL17983	1 pieza junta para motores con retén trasero de dos piezas.	1 piece PermaDry molded rubber gasket for engines w/Two-piece rear main bearing seal	Guarnizione in 1 pz, paraolio posteriore in 2 px.
FEL17980	Varilla aceite a babor con retén trasero de dos piezas y junta cárter de 4 piezas.	Port dipstick w/Two-piece rear main bearing seal & Four-piece oil pan gskt.	Asticella olio a SINISTRO con praolio
FEL17981	Varilla aceite a estribor con retén trasero de dos piezas y junta cárter de 4 piezas.	Starboard dipstick w/Two-piece rear main bearing seal & Four-piece oil pan gskt	Asticella olio DESTRO con paraolio posteriore in 2 pz e guarnizione coppa da 4 pz.
	<b>RETÉN TRASERO CIGÜEÑAL</b>	<b>CRANKSHAFT REAR SEAL</b>	<b>PARAOLIO POSTERIORE ALBERO MOTORE</b>
FEL17725	Retén partido Contrarrotación, goma; dos piezas	Split seal Rev. rotation, rubber; two-piece	Controrotazione in 2 pz.
	<b>TAPA VÁLVULAS</b>	<b>VALVE COVER</b>	<b>COPERCHIO VALVOLE</b>
FEL17931	KIT JUNTA Tornillo centro tapa válvulas con juntas. Tornillo central	PermaDry molded rubber gskts. incl.	Coperchio punterie con viti centrali..
FEL17930	Tornillo en el canto.	Rim bolt desing	Coperchio punterie con viti nel perimetro.

**BLACK SCORPION (315 HP) 5.7L: 230, 235, 260 HP,  
5.7L BLUE WATER INBOARD 250, 260 HP  
5.7L BRAVO, 240, 250, 270 HP  
5.7L COMP SKI, 250, 260 HP, 255 HP, 300, 300 MR/TR,  
350 MAGNUM, 350 MAGNUM TOURNAMENT SKI (240, 250, 265, 270 HP)**

Ref	Descripción	Description	Descrizione
	<b>CULATA</b>	<b>CYLINDER HEAD</b>	<b>TESTATA</b>
FEL17030	JUNTA CULATA Se necesitan dos	CYLINDER HEAD 2 required	GUARNIZIONE TESTATA Necessarie 2
FEL17214	KIT JUNTAS SUPERIOR Excepto Gen+ con juntas plástico colector admisión, Tornillo centro tapa válvulas con juntas tapa válvulas. Retenes válvulas.	GASKET HEAD SET Exc. GEN+ eng. w/Center bolt design valve covers; valve cover gskts. incl. Premium valve stem seals incl.	KIT PARTE ALTA Eccetto Gen+ con guarnizione aspirazione in plastica. Coperchio punterie con viti nel centro. Include paraoli valvole.
FEL17230	KIT JUNTAS SUPERIOR Excepto Gen+ con juntas plástico colector admisión, Tornillo borde tapa válvulas con juntas tapa válvulas. Incluye retenes válvulas.	GASKET HEAD SET Exc. GEN+ eng. w/Rim bolt desing valve covers; valve cover gskts. incl. Premium valve stem seals incl.	KIT PARTE ALTA Eccetto Gen+ con guarnizione aspirazione in plastica, coperchio punterie conviti nel perimetro. Include paraolio valvole.
FEL17232	KIT JUNTAS SUPERIOR Gen+ con juntas plástico colector admisión, con juntas tapa válvulas. Retenes válvulas incluidos.	GASKET HEAD SET GEN+ w/ plastic intake manifold gskts. valve cover gskts. incl; Premium valve stem seals incl.	KIT PARTE ALTA Gen+ con guarnizione aspirazione in plastica con guarnizione PermaDry. Includi paraolio valvole.
	<b>INFERIOR</b>	<b>CONVERSION</b>	<b>PARTE BASSA</b>
FEL17125	KIT JUNTAS INFERIOR Sin tapa de distribución de plástico, retén trasero de una pieza y junta cárter de una pieza. Junta de cárter de goma PermaDry incluida.	GASKET SET Eng. w/o plastic timing cover, 1 piece rear main bearing seal & one piece oil pan gskt. molded rubber oil pan gskt incl.	KIT PARTE BASSA Carter distribuzione in metallo, paraolio posteriore in 1 pz e guarnizione coppa olio in 1 pz.
FEL17124	KIT JUNTAS INFERIOR Con tapa de distribución de plástico, retén trasero de una pieza y junta cárter de una pieza. Junta de cárter incluida.	CONVERSION GASKET SET Eng. with plastic timing cover, 1 piece rear main bearing seal & one piece oil pan gskt. oil pan gskt incl.	KIT PARTE BASSA Carter distribuzione in plastica, paraolio posteriore in 1 pz e guarnizione coppa olio in 1 pz.
FEL17120	KIT JUNTAS INFERIOR Retén de dos piezas y junta cárter de 4 piezas	CONVERSION GASKET SET Two-piece rear main bearing seal & 4	KIT PARTE BASSA Paraolio posteriore in 2 pz e guarnizione coppa in 4 pz.



Ref	Descripción	Description	Descrizione
	<b>COLECTOR ADMISIÓN-ESCAPE</b>	<b>MANIFOLD INTAKE &amp; EXHAUST</b>	<b>ASPIRAZIONE - SCARICO</b>
FEL17320	Kit Junta Admisión-Escape Excepto GEN+ con juntas de admisión de plástico.	Intake-Exhaust Gasket Set Excl. GEN+ eng. w/plastic intake gaskets.	Kit guarnizioni aspirazione Eccetto Gen+ guarnizione in plastica
REC27-807473A1	Junta Admisión Vortec (2 unid.) Junta de plástico.	Intake Gasket Vortec (2 units) Gasket in plastic.	Guarnizione Vortec necessita 2 pz guarnizione in plastica
FEL17420	Kit juntas colector -escape	Oil pan gasket set	Kit guarnizione scarico
	<b>CARTER</b>	<b>OIL PAN</b>	<b>COPPA DELL'OLIO</b>
FEL17982	1 pieza junta cárter incluye Junta de cárter.	1 piece oil pan gasket. PermaDry molded rubber oil pan gasket included	guarnizione in 1 pz.
FEL17983	1 pieza junta goma para motores con retén trasero de dos piezas.	1 piece PermaDry molded rubber gasket for engines w/Two-piece rear main bearing seal	Guarnizione in 1 pz, paraolio posteriore in 2 px.
FEL17980	Varilla aceite a babor con retén trasero de dos piezas y junta cárter de 4 piezas.	Port dipstick w/Two-piece rear main bearing seal & Four-piece oil pan gskt.	Asticella olio a SINISTRO con paraolio
FEL17981	Varilla aceite a estribor con retén trasero de dos piezas y junta cárter de 4 piezas.	Starboard dipstick w/Two-piece rear main bearing seal & Four-piece oil pan gskt	Asticella olio DESTRO con paraolio posteriore in 2 pz e guarnizione coppa da 4 pz.
	<b>RETÉN TRASERO CIGÜEÑAL</b>	<b>CRANKSHAFT REAR SEAL</b>	<b>PARAOLIO POSTERIORE ALBERO MOTORE</b>
FEL17725	Retén Contrarrotación de dos piezas	Split seal Rev. rotation, rubber; two-piece	Controrotazione in 2 pz.
	<b>TAPA VÁLVULAS</b>	<b>VALVE COVER</b>	<b>COPERCHIO VALVOLE</b>
FEL17931	KIT JUNTA Tornillo centro tapa válvulas con juntas de goma PermaDry.	w/Center bolt desing valve PermaDry molded rubber gskts. incl.	Coperchio punterie con viti centrali.
FEL17930	KIT JUNTA Tornillo lateral	Rim bolt desing	Coperchio punterie con viti nel perimetro.
	<b>RETÉN DISTRIBUCIÓN</b>	<b>OIL SEAL TIMING COVER</b>	<b>PARAOLIO DISTRIBUZIONE</b>
REC3853341	Reten contrarrotación Motor sin tapa distribución de plástico.	Reverse rotation oil seal Engines w/o plastic timing cover.	Paraolio controrotante. Motore con carter distribuzione in plastica.

5.8L 233 (3258728 - 4175499) (233 HP)  
 255 (3258728 - 4175499) (255 HP)  
 BASE FORD BLOCK

Ref	Descripción	Description	Descrizione
	<b>CULATA</b>	<b>CYLINDER HEAD</b>	<b>TESTATA</b>
FEL17060	JUNTA CULATA Se necesitan dos	CYLINDER HEAD 2 required	GUARNIZIONE TESTATA Necessarie 2
FEL17260	KIT JUNTAS SUPERIOR Con retenes valvula.	GASKET HEAD SET Premium valve stem	KIT PARTE ALTA Include paraolio valvole
	<b>INFERIOR</b>	<b>CONVERSION</b>	<b>PARTE BASSA</b>
FEL17165	KIT JUNTAS INFERIOR	CONVERSION GASKET SET	KIT PARTE BASSA
	<b>COLECTOR ADMISIÓN- ESCAPE</b>	<b>MANIFOLD INTAKE &amp; EXHAUST</b>	<b>ASPIRAZIONE - SCARICO</b>
FEL17360	Kit Junta Admisión	Intake Gasket Set	Kit guarnizioni aspirazione
FEL17460	Kit Junta escape	Exhaust Gasket Set	Kit guarnizioni scarico
	<b>CARTER</b>	<b>OIL PAN</b>	<b>COPPA DELL'OLIO</b>
FEL17996	Kit Juntas Carter	Gasket Oil Pan Set	Kit guarnizione coppa dell'olio
	<b>TAPA VÁLVULAS</b>	<b>VALVE COVER</b>	<b>COPERCHIO VALVOLE</b>
FEL17945	KIT JUNTA	Gasket set	kit guarnizioni

7.4L 454 V8: 420 HP GEN IV & V  
425 (385, 400, 425 HP GEN IV & V)  
525 SC (500 HP GEN V)  
7.4L BLUE WATER INBOARD (-D715493) (310, 340 HP GEN IV)  
7.4L BLUE WATER INBOARD (D715494+) (310 HP GEN V)  
7.4L BRAVO (-D603117) (300, 330 HP GEN. IV)  
7.4L BRAVO I (D603118+) (300, 330 HP GEN V)  
7.4L BRAVO II (D603118+) (300, 330 HP GEN V)  
7.4L BRAVO III (D603118+) (3350 HP GEN V)  
7.4L EFI (F215800+) (310 HP GEN V), 330, 340, 350, 370TRS,  
400 TRS GEN IV, 450 HP GENE V  
454 MAGNUM ALPHA (A631894 - B785148) (330 HP GEN IV)  
454 MAGNUM BRAVO (B721206 - D805068) (350, 365 HP GENE IV)  
454 MAGNUM BRAVO (D805069+) (350 HP GENE V)

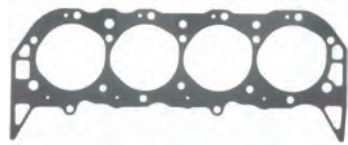

Ref	Descripción	Description	Descrizione
	<b>CULATA</b>	<b>CYLINDER HEAD</b>	<b>TESTATA</b>
FEL17040	JUNTA CULATA Gene IV exc. H.O. Se necesitan dos	CYLINDER HEAD Gene IV exc. H.O. 2 required	GUARNIZIONE TESTATA Gene IV escluso H.O. Necessarie 2
FEL17049	JUNTA CULATA Gene IV sólo H.O. super medida Se necesitan 2.	CYLINDER HEAD Gene IV H.O. only super bore 2 required	GUARNIZIONE TESTATA Gene IV solo H.O. maggiorata. Necessarie 2
FEL17046	JUNTA CULATA Gene IV sólo H.O. Se necesitan 2.	CYLINDER HEAD Gene IV H.O. only 2 required	GUARNIZIONE TESTATA Gene IV solo H.O. Necessarie 2
FEL17042	JUNTA CULATA Gene IV & V. Se necesitan 2.	CYLINDER HEAD Gene IV & V. 2 required	GUARNIZIONE TESTATA Gene IV e V. Necessarie 2
FEL17240	KIT JUNTAS SUPERIOR Gene IV exc. H.O. con admisión ovalada. Se incluye retenes de válvula	GASKET HEAD SET Gen IV exc. H.O. w/oval intake ports; premium valve stem seals incl.	KIT PARTE ALTA Gene IV escluso H.O. con aspirazione ovale. Includi paraoli valvole.
FEL17241	KIT JUNTAS SUPERIOR Gene IV exc. H.O. con admisión rectangular. Se incluye retenes de válvula	GASKET HEAD SET Gen IV exc. H.O. w/rectangular intake ports; premium valve stem seals incl.	KIT PARTE ALTA Gene IV escluso H.O. con aspirazione rettangolare. Includi paraoli valvole.

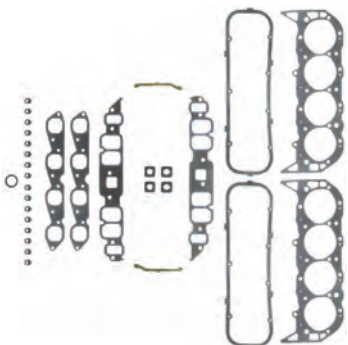
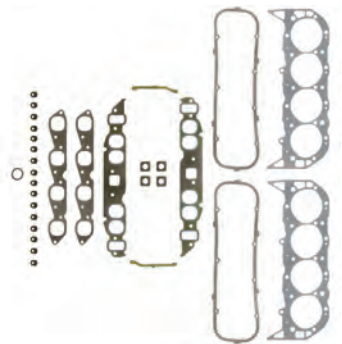

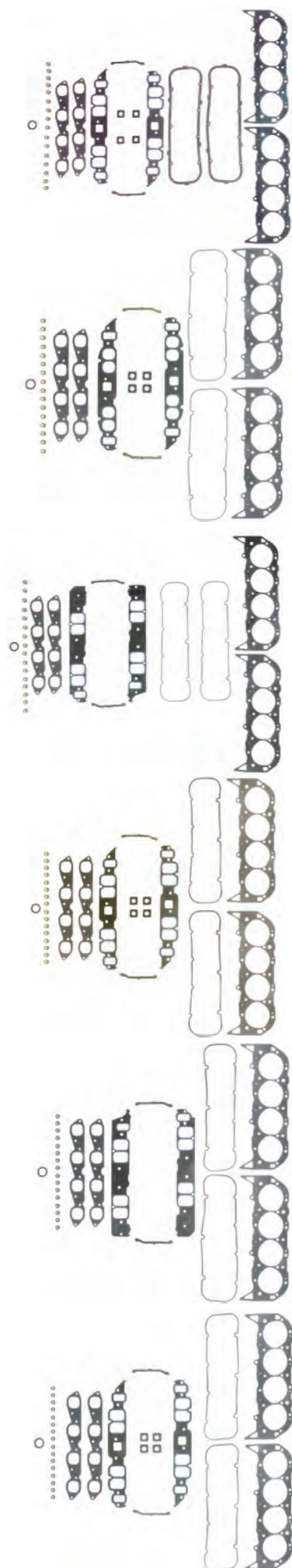

Ref	Descripción	Description	Descrizione
FEL17246	KIT JUNTAS SUPERIOR Gene IV sólo H.O. con admisión rectangular. Se incluye retenes de válvula	GASKET HEAD SET Gen IV only H.O. w/rectangular intake ports; premium valve stem seals incl.	KIT PARTE ALTA Gene IV solo H.O. con aspirazione rettangolare. Includi paraoli valvole.
FEL17242	KIT JUNTAS SUPERIOR Gene V exc. EFI y H.O. con admisión ovalada. Se incluye retenes de válvula.  Gene VI exc. EFI y H.O. con admisión ovalada, juntas de goma PermaDry de tapa válvulas y retenes incluidos	GASKET HEAD SET Gen V exc. EFI or H.O. w/oval intake ports; premium valve stem seals incl.  Gen VI, exc. EFI & H.O. w/oval intake port PermaDry molded rubber valve cover gskts and premium valve stem seals incl.	KIT PARTE ALTA Gene V escluso EFO e H.O. con aspirazione ovale. Include paraoli valvole.  Gene VI, exc. EFI e H.O. con aspirazione ovale, guarnizione coperchio punterie e paraoli inclusi.
FEL17280	KIT JUNTAS SUPERIOR Gene V solo EFI juntas de retenes incluidos.	GASKET HEAD SET Gen V, EFI only, valve cover gskts and premium valve stem	KIT PARTE ALTA Gene V solo EFO, guarnizione in gomma del coperchio. Include paraoli valvole.
FEL17243	KIT JUNTAS SUPERIOR Gene V solo H.O. con admisión rectangular, juntas tapa válvulas y retenes incluidos.	GASKET HEAD SET Gen V, H.O. only, w/rectangular intake ports valve cover gskts and premium valve stem seals incl.	KIT PARTE ALTA Gene V solo H.O. con aspirazione rettangolare, guarnizione coperchio punterie e paraoli inclusi.
FEL17205	KIT JUNTAS SUPERIOR Gene VI sólo EFI juntas de tapa válvulas y retenes incluidos.	GASKET HEAD SET Gen VI, EFI only, valve cover gskts and premium valve stem seals incl.	KIT PARTE ALTA Gene VI, solo EFI guarnizione rettangolare, guarnizione coperchio punterie e paraoli inclusi.
FEL17201	KIT JUNTAS SUPERIOR Gene VI solo H.O. con admisión rectangular, juntas de tapa válvulas y retenes incluidos.	GASKET HEAD SET Gen VI, H.O. only, w/rectangular intake ports valve cover gskts and premium valve stem seals incl.	KIT PARTE ALTA Gene VI, solo H.O. con aspirazione coperchio punterie e paraoli inclusi.

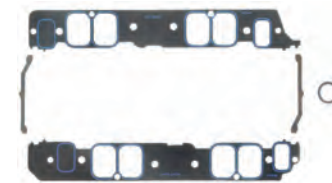
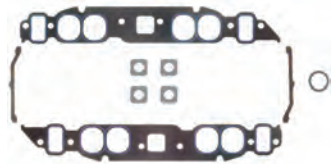
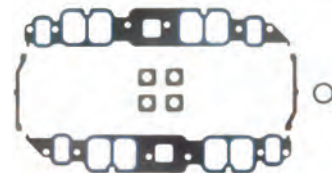
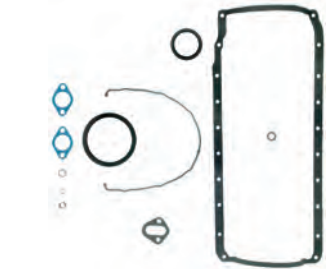
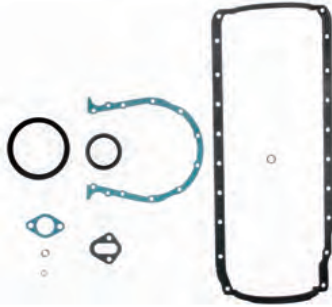
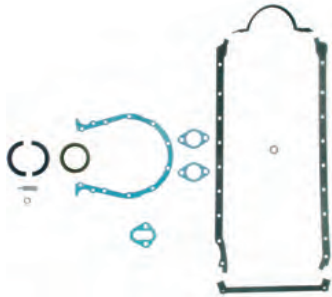

Ref	Descripción	Description	Descrizione
	<b>INFERIOR</b>	<b>CONVERSION</b>	<b>PARTE BASSA</b>
FEL17140	KIT JUNTAS INFERIOR Gene IV con retén trasero de dos piezas y junta cárter de 4 piezas.	CONVERSION GASKET SET Gene IV w/two piece rear main bearing seal & four piece oil pan gskt.	KIT PARTE BASSA Gene IV con paraolio posteriore in 2 pz. e guarnizione coppa dell'olio in 4 pz.
FEL17145	KIT JUNTAS INFERIOR Gene V con retén trasero de una pieza y junta cárter de 1 pieza. Junta cárter incluida.	CONVERSION GASKET SET Gene V w/one piece rear main bearing seal & one piece oil pan gskt. oil pan gskt. incl.	KIT PARTE BASSA Gene V con paraolio posteriore in 1 pz. e guarnizione coppa dell'olio in 1 pz.
FEL17146	KIT JUNTAS INFERIOR Gene VI con retén trasero de una pieza y junta cárter de 1 pieza. Junta cárter incluida.	CONVERSION GASKET SET Gene VI w/one piece rear main bearing seal & one piece oil pan gskt. oil pan gskt. incl.	KIT PARTE BASSA Gene VI con paraolio posteriore in 1 pz. e guarnizione coppa dell'olio in gomma PermaDry in 1 pz.
	<b>COLECTOR ADMISIÓN- ESCAPE</b>	<b>MANIFOLD INTAKE &amp; EXHAUST</b>	<b>ASPIRAZIONE - SCARICO</b>
FEL17341	KIT JUNTA ADMISIÓN Gene IV, V y VI sólo H.O. con admisión rectangular.  Gene IV, excl. H.O. con admisión rectangular.	INTAKE GASKET SET Gene IV, V & VI, H.O. only w/ rectangular intake ports  Gene IV excl. H.O. w/rect. intake ports	KIT GUARNIZIONI ASPIRAZIONE Gene IV, V e VI solo H.O. con aspirazione rettangolare  Gene IV escluso H.O. con aspirazione rettangolare
FEL17340	KIT JUNTA ADMISIÓN Gene IV, excl. H.O. con admisión oval.  Gene V y VI exc. EFI y H.O. con admisión ovalada.	INTAKE GASKET SET Gene IV excl. H.O. w/oval intake ports  Gene V & VI, excl. EFI & H.O. w/oval intake ports	KIT GUARNIZIONI SCARICO Gene IV escluso H.O. con aspirazione ovale.  Gene V e VI escluso EFI e H.O. con aspirazione ovale
FEL17342	KIT JUNTA ADMISIÓN Gene V y VI sólo EFI	INTAKE GASKET SET Gene V & VI, EFI only	KIT GUARNIZIONI SCARICO Gene V e VI, solo EFI
FEL17440	KIT JUNTA ESCAPE Gene IV, V y VI.	EXHAUST GASKET SET Gene IV, V & VI	KIT GUARNIZIONI SCARICO Gene IV, V e VI
	<b>RETÉN TRASERO CIGÜEÑAL</b>	<b>CRANKSHAFT REAR SEAL</b>	<b>PARAOILIO POSTERIORE ALBERO MOTORE</b>
FEL17740	Gene IV Retén Contrarrotación; dos piezas	Gene IV Reverse rotation oil seal. Two-pieces	Gene IV Controrrotante in 2 pz.



Ref	Descripción	Description	Descrizione
	<b>TAPA VÁLVULAS</b>	<b>VALVE COVER</b>	<b>COPERCHIO VALVOLE</b>
FEL17935	KIT JUNTA Gene IV	GASEKT SET Gene IV	KIT GUARNIZIONI Gene IV
FEL17937	KIT JUNTA Gene V & VI	GASEKT SET Gene V & VI	KIT GUARNIZIONI Gene V e VI

**8.2L 502 V8 HP465 (465 HP GEN. V) HP 600 SC (550HP GEN. V)  
8.5L (-D857199) (400 HP GEN. IV)  
8.2L (D857200 - F819619) (400 HP GEN.V)  
500 (470 HP GEN V)  
502 MAGNUM BRAVO (-D824588) (390HP GEN IV)  
502 MAGNUM BRAVO (D824589+) (390 & 415 HP GEN. V)**

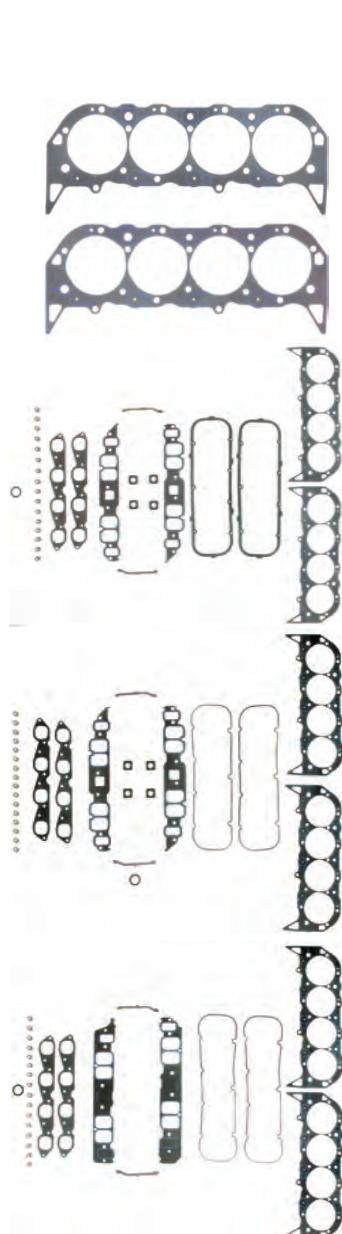

Ref	Descripción	Description	Descrizione
	<b>CULATA</b>	<b>CYLINDER HEAD</b>	<b>TESTATA</b>
FEL17049	JUNTA CULATA Gene IV, V & VI super medida Se necesitan 2.	CYLINDER HEAD Gene IV, V & VI super bore. 2 required	GUARNIZIONE TESTATA Gene IV, V e VI maggiorata, necessita 2
FEL17048	JUNTA CULATA Gene IV, V & VI .Se necesitan 2.	CYLINDER HEAD Gene IV, V & VI. 2 required	GUARNIZIONE TESTATA Gene IV, V e VI. necessita 2
FEL17248	KIT JUNTAS SUPERIOR Gene IV. Se incluye retenes de válvula.	GASKET HEAD SET Gene IV. premium valve stem seals incl.	KIT PARTE ALTA Gene IV. Se include paraoli valvole.
FEL17249	KIT JUNTAS SUPERIOR Gene V exc. EFI. Se incluye retenes de válvula y juntas tapa válvulas.	GASKET HEAD SET Gen V exc. EFI; premium valve stem seals & valve cover gsks. incl.	KIT PARTE ALTA Gene IV escluso EFI. Include paraolio e guarnizione del coperchio valvola
FEL17281	KIT JUNTAS SUPERIOR Gene V solo EFI. Se incluye retenes de válvula y juntas tapa válvulas.	GASKET HEAD SET Gen V EFI only; premium valve stem seals & valve cover gsks. incl.	KIT PARTE ALTA Gene V solo EFI. Include paraolio e guarnizione del coperchio valvola



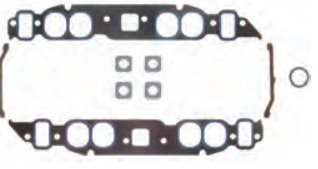
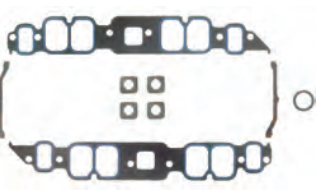
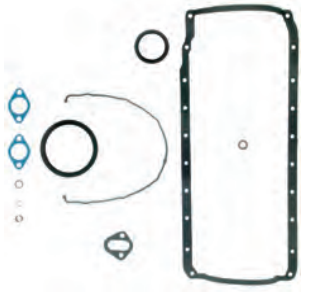
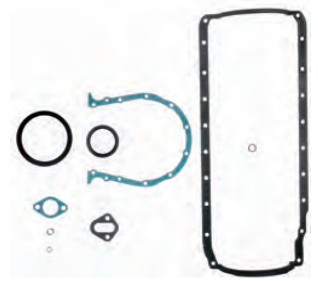
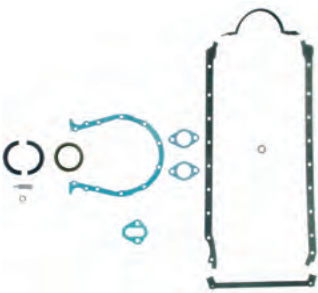
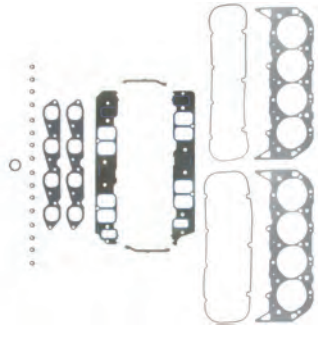

Ref	Descripción	Description	Descrizione
FEL17207	KIT JUNTAS SUPERIOR Gene VI solo EFI. Se incluye retenes de válvula y juntas tapa válvulas	GASKET HEAD SET Gen VI EFI only; premium valve stem seals & valve cover gsks. incl.	KIT PARTE ALTA Gene VI solo EFI. Include paraolio e guarnizione del coperchio valvola
	<b>INFERIOR</b>	<b>CONVERSION</b>	<b>PARTE BASSA</b>
FEL17140	KIT JUNTAS INFERIOR Gene IV con retén trasero de dos piezas y junta cárter de 4 piezas.	CONVERSION GASKET SET Gene IV w/two piece rear main bearing seal & four piece oil pan gskt.	KIT PARTE BASSA Gene IV con paraolio posteriore in 2 pz. e guarnizione coppa dell'olio in 4 pz.
FEL17145	KIT JUNTAS INFERIOR Gene V con retén trasero de una pieza y junta cárter de 1 pieza. Junta cárter de goma PermaDry incluida.	CONVERSION GASKET SET Gene V w/one piece rear main bearing seal & one piece oil pan gskt. PermaDry molded rubber oil pan gskt. incl.	KIT PARTE BASSA Gene V con paraolio posteriore in 1 pz. e guarnizione coppa dell'olio in 1 pz.
FEL17146	KIT JUNTAS INFERIOR Gene VI con retén trasero de una pieza y junta cárter de 1 pieza. Junta cárter incluida.	CONVERSION GASKET SET Gene VI w/one piece rear main bearing seal & one piece oil pan gskt. oil pan gskt. incl.	KIT PARTE BASSA Gene VI con paraolio posteriore in 1 pz. e guarnizione coppa dell'olio in 1 pz.
	<b>COLECTOR ADMISIÓN-ESCAPE</b>	<b>MANIFOLD INTAKE &amp; EXHAUST</b>	<b>ASPIRAZIONE - SCARICO</b>
FEL17341	KIT JUNTA ADMISIÓN Gene IV Gene V, excl. EFI	INTAKE GASKET SET Gene IV Gene V excl. EFI	KIT GUARNIZIONI ASPIRAZIONE Gene IV Gene V escluso EFI
FEL17340	KIT JUNTA ADMISIÓN Gene V y VI sólo EFI	INTAKE GASKET SET Gene V & VI, EFI only	KIT GUARNIZIONI SCARICO Gene V e VI solo EFI
	<b>RETÉN TRASERO CIGÜEÑAL</b>	<b>CRANKSHAFT REAR SEAL</b>	<b>PARAOLIO POSTERIORE ALBERO MOTORE</b>
FEL17740	Gene IV Retén Contrarrotación; dos piezas	Gene IV Reverse rotation oil seal. Two-pieces	Gene IV Controrotante in 2 pz.

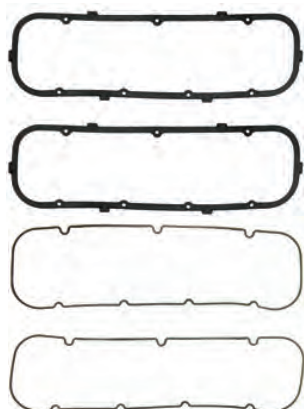

Ref	Descripción	Description	Descrizione
	<b>TAPA VÁLVULAS</b>	<b>VALVE COVER</b>	<b>COPERCHIO VALVOLE</b>
FEL17935	KIT JUNTA Gene IV	GASEKT SET Gene IV	KIT GUARNIZIONI Gene IV
FEL17937	KIT JUNTA Gene V & VI	GASEKT SET Gene V & VI	KIT GUARNIZIONI Gene V e VI

**JUNTAS DISTRIBUCIÓN  
TIMING GASKETS  
GUARNIZIONE DISTRIBUZIONE**

Ref.	R.O. OEM
REC27-34895A2	27-34895A2

**MOTORES / ENGINES / MOTORI**  
GM 305 & 350 CID, 200, 225, 228, 230, 250, 255, 260, 270, 280 HP  
898 (198 HP), 5.7 (SKY) (-1997)



Ref.	R.O. OEM
REC27-54529A1	27-54529A1

**MOTORES / ENGINES / MOTORI**  
GM 454 CID  
325, 330, 340 & 350  
300 TRS (-1991)



**TAPA DISTRIBUCIÓN  
TIMING CHAIN COVER  
CARTER**

Ref.	R.O. OEM
REC27-49953	27-49953

**MOTORES / ENGINES / MOTORI**  
4 & 6 Cyl.  
GM120, 140, 160/165, 2.5L, 3.0LX/L (1963+)



Ref.	R.O. OEM
REC27-850456	27-85046

**MOTORES / ENGINES / MOTORI**  
454, 502 / 7.4 & 8.2L GEN V & VI (1996+)  
Race Sterndrive 500, 520, 525, 540, 565, 575, 600, 662, 700



Ref.	R.O. OEM
REC27-54529	27-54529

**MOTORES / ENGINES / MOTORI**  
454 CID  
427, 454, 482, 502 (-1992)



Ref.	R.O. OEM
REC27-56108	27-56108

**MOTORES / ENGINES / MOTORI**  
FORD V8 302, 351 (1970-77)



Ref.	R.O. OEM
REC27-68714A6	27-68714

**MOTORES / ENGINES / MOTORI**  
224 CID  
165, 170, 180, 190, 470, 485 & 488

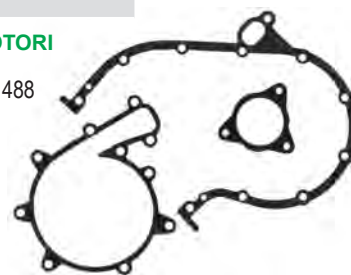

Ref.	R.O. OEM
REC27-14250	27-14250

**MOTORES / ENGINES / MOTORI**  
V6 & V8 (-1997)



# RETENES SEALS TENUTE

## GUIA RETENES ACEITE OIL SEALS GUIDE GUIDA PARAOLIO

REF.	R.O. OEM	Ø EJE (") SHAFT Ø (") Ø ASSE (")	Ø EXTERIOR (") OUTER Ø (") Ø ESTERNO (")
REC26-12224	26-12224	1.1875	1.6875
REC26-12709	26-12709	0.5000	0.6875
REC26-76868	26-14077	1.1875	1.6875
REC26-14240	26-14240	3.8125	4.5000
REC26-16977	26-16977	0.8750	1.2500
REC908855	26-20070	0.6250	1.0000
REC26-23517	26-23517	0.7500	1.2500
REC310599	26-26226	1.0000	1.5000
REC26-30530	26-30530	0.5625	1.0000
REC26-30913	26-30913	0.5000	1.1875
REC26-24590	26-31249	0.3750	0.5625
REC26-32511	26-32511	1.2500	2.0000
REC26-32911	26-32911	1.1250	1.2500
REC26-33467	26-33467	0.6250	1.1250
REC26-419533	26-41953	1.1875	1.8750
REC26-43035	26-43035	1.0625	1.4375
REC26-43036	26-43036	1.0312	1.4687
REC26-455771	26-45577 1	0.3125	0.4375
REC26-45587	26-45587	0.3750	0.6250
REC26-48443	26-48443	0.7500	1.3750
REC26-55682	25-55682	1.0000	1.2500
REC26-56397	26-56397	0.7500	1.1250
REC26-56788	26-56788	0.8750	1.2500
REC26-62818	26-62818	1.6250	2.2500
REC26-66302	26-66302	1.2500	1.8750
REC26-69188	26-69188	0.8750	1.2500
REC26-69189	26-69189	0.8750	1.3125
REC26-70081	26-70081	1.1875	1.7500
REC26-72785	26-72785	0.7500	1.8750
REC26-76868	26-76868	1.1875	1.6875
REC26-79831	26-79831	0.7500	1.1250
REC26-861694	26-805080	2.5000	3.1875
REC26-807006	26-807006	1.6875	2.2500
REC26-8164641	26-8164641	0.3750	0.7500
REC26-821092	26-821092	1.5000	2.2500
REC26-823894	26-823894	2.2500	3.0000
REC26-24590	26-892361	0.3750	0.7500
REC26-89238	26-89238	0.8750	1.5000
REC26-90562	26-90562	0.7500	1.2500
REC26-94038	26-94038	1.0000	1.5000
REC26-897153	26-96063	0.4375	0.8750
REC26-965031	26-965031	0.8750	1.3750
REC26-43993	26-43993	1.640	2.132
REC26-67388	26-67388	1.800	3.100
REC26-33467	26-33467	0.625	1.125
REC26-16977	26-16977	0.875	1.250
REC26-24590	26-24590	0.400	0.566
REC26-55682	26-55682	1.000	1.253

Medidas en Pulgadas / Diameters in Inches / Misure in pollici 1" = 25,4 mm

## GUIA AROS TÓRICOS O-RINGS GUIDE GUIDA ANELLI TENUTE

REF.	R.O. OEM	REF.	R.O. OEM
REC25-20081	25-20081	REC301967	25-36318
REC25-16524	25-20415	REC25-38099	25-38099
REC25-16524	25-16524	REC25-38101	25-38101
REC308627	25-20826	REC25-38933	25-38933
REC25-80863	25-20863	REC326849	25-39695
REC25-21836	25-21836	REC25-457101	25-457101
REC125017	25-23145	REC326649	25-45711
REC25-25439	25-25439	REC310414	25-47254
REC333572	25-26543	REC0554545	25-47632
REC302588	25-26722	REC25-48171	25-48171
REC303347	25-26802	REC302035	25-48452
REC3852928	25-26855	REC25-33465	25-54029
REC309731	25-29439	REC25-55801	25-55801
REC25-30224	25-30224Q	REC909140	25-58390
REC25-30529	25-30529	REC25-62700	25-62700
REC25-30613	25-30613	REC3852045	25-62704
REC553126	25-31305	REC25-62705	25-62705
REC3852866	25-31986	REC25-62706	25-62707
REC304174	25-32509	REC25-823683	25-823683
REC25-32546	25-32546	REC333572	25-64068
REC25-33145	25-33145	REC331188	25-65936
REC25-33465	25-33465	REC313175	25-67202
REC302537	25-33466	REC25-67202	25-67202
REC0307239	25-33504	REC25-70937	25-70937
REC305123	25-33756	REC3852865	25-805331
REC25-35029	25-35029	REC25-89497	25-89497
REC310584	25-35276	REC25-90011	25-90011
REC321921	25-35480	REC25-97387	25-97387

## RETENES VÁLVULAS VALVE STEM SEAL PARAOLIO VALVOLE

Ref.	R.O. OEM
REC26-34217	26-34217

**MOTORES / ENGINES / MOTORI**  
4 en línea y 6 cil antiguos, GM V6/V8  
Most inline 4 & 6 cyl. GM (early) GM V6/V8  
4 en linea e 6 cil vecchio mod. GM V6/V8



Ref.	R.O. OEM
REC26-75988	26-75988

**MOTORES / ENGINES / MOTORI**  
330 (4623115+)  
340 (5889914+)  
454 Mag d(A631894+)



**VÁLVULA ADMISIÓN  
INTAKE VALVE  
VALVOLA ASPIRAZIONE**

Ref.	R.O. OEM
REC70817B	26-97664 26-976641 26-8M0050563

**MOTORES / ENGINES / MOTORI**

4.3L, 5.0L, & 5.7L old & MPI  
(1983-97)

**ADMISIÓN Y ESCAPE  
INTAKE & EXHAUST VALVE  
ASPIRAZIONE E SCARICO**

Ref.	R.O. OEM
REC26-75624	26-75624 26-75413

**MOTORES / ENGINES / MOTORI**

165, 170, 180, 190 4 CIL. (224 cid) (6916779+)  
888 (2bbi) Ford 302 V8 (1971-77)  
3.7 L, LX (1980-89)  
470 (1976-81) 488 (1983-84)



**RETENES CIGÜEÑAL  
CRANKSHAFT OIL SEALS  
PARAOLIO ALBERO MOTORE**

Ref.	R.O. OEM
FELBS40013	26-814622

**MOTORES / ENGINES / MOTORI**

5.0, 5.7L (-1986)

Ref.	R.O. OEM
REC26-14240	26-14240

**MOTORES / ENGINES / MOTORI**

4.3, 5.0, 5.7L  
Standard Rot.

Ref.	R.O. OEM
REC26-14756	26-14756

**MOTORES / ENGINES / MOTORI**

7.4, 8.2L (1991+)

Ref.	R.O. OEM
REC3853341	36-97335
REC26-8219471	26-8219471
REC26-67388	26-67388
REC26-8219471	26-8219471

Ref.	R.O. OEM
REC26-14240	26-14240
REC26-811554	26-811554
REC26-90925	26-90925
RM26-879194364	
FEL17725	

Ref.	R.O. OEM
FEL17740	26-75980



**GUIA RETENES CIGÜEÑAL  
CRANKSHAFT OIL SEALS GUIDE  
GUIDA PARAOLIO ALBERO MOTORE**

MODELO MODEL MODELLO	SERIE SERIAL SERIE	TRASER REAR POSTERIORE	DELANTERO FRONT ANTERIORE
120/2.5L	1666601		REC3853341
120/2.5L	2786857	FELBS40013	REC3853341
140/3.0L & LX	2508261		REC3853341
140/3.0L & LX	6229718	FELBS40013	REC3853341
150, 160, 165, 200 (I/L-6)	1666495+		REC3853341
150, 160, 165, 200 (I/L-6)	2770032+	FELBS40013	REC3853341
175, 185, 205, 262 4.3L (V-6)	6330183+	FELBS40013	REC3853341
200, 228, 225, 230, 250, 255, 260, 270, 280, 300, 320 5.0L/5.7L/898 (V-8)	2453769+	FELBS40013	REC3853341
224I/L4		REC26-90925	REC26-67388
5.0L, 5.7L, 4.3L, 3.0L Rotación standard. 1 pieza STD Rotation. 1 piece Rotazione STD. 1 pezzo		REC26-14240	REC3853341
340 (7.4L)	4623115+	FEL17740	REC26-8219471
370 TRS	5889914		REC26-8219471
400 TRS	4179554		REC26-8219471
420	A398941+		REC26-8219471
440 TRS	4179554		REC26-8219471
454 MAGNUM	A631894+		REC26-8219471
460 TRS	4179554		REC26-8219471
7.4, 8.2L, 454, 502 Rotación standard. 1 pieza STD Rotation. 1 piece Rotazione STD. 1 pezzo		REC26-811554	REC26-8219471
7.4 BRAVO	B771113+		REC26-8219471

470, 485, 488, 165, 170, 180 & 190 HP  
4 CYL EN LÍNEA / IN LINE / IN LINEA

92

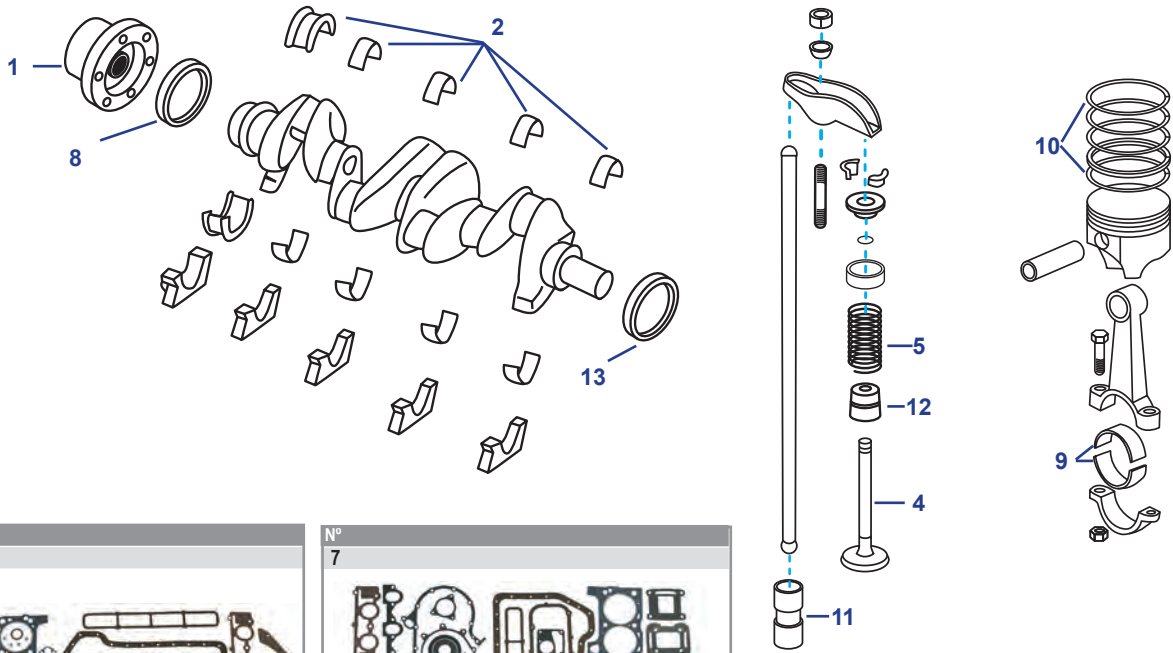

Nº	Ref.	R.O. OEM	Descripción	Description	Descrizione	Cantidad Qty Quantità
1	REC97432A2	97432A2	ACOPLAMIENTO MOTOR 470 (1983-89), 165, 170, 3.7L	ENGINE COUPLER ASSEMBLY MODEL 470 (1983-89), 165, 170, 3.7L	GIUNTO PARASTRAPPI 470 (1983-89), 165, 170, 3.7L	1
1	REC69354A2	69354A2	ACOPLAMIENTO MOTOR 470 y 485 (1976-82)	ENGINE COUPLER ASSEMBLY MODEL 470 & 485 (1976-82)	GIUNTO PARASTRAPPI 470 e 485 (1976-82)	1
2	FED7205M	23-853849	KIT COJINETES BANCADA STD. TODOS LOS MOTORES	BEARING SET STD. ALL MODELS	KIT BRONZINE DI BANCO STD. TUTTI I MODELLI	1
4	FEDV-3929	75416	VÁLVULA ADMISIÓN 470	INTAKE VALVE 470	VALVOLA ASPIRAZIONE 470	4
4	RM44181A1	44181A1	VÁLVULA ADMISIÓN RESTO MOTORES EXCEPTO 485	INTAKE VALVE ALL MODELS EXCEPT 485	VALVOLA ASPIRAZIONE RESTO DEI MODELLI ECCETTO 485	4
4	FEDV-1984	44182A1	VÁLVULA ESCAPE 470	EXHAUST VALVE 470	VALVOLA SCARICO 470	4
4	RM44182A1	44182A1	VÁLVULA ESCAPE RESTO MOTORES EXCEPTO 485	EXHAUST VALVE ALL MODELS EXCEPT 485	VALVOLA SCARICO RESTO DEI MODELLI ECCETTO 485	4
5	REC24-56159	24-75411T	MUELLE VÁLVULA	SPRING VALVE	MOLLA VALVOLA	8
6	REC27-74830A3	27-74830A3	KIT JUNTAS MOTORES 224 (3.7L) 470	ENGINE GASKET SET	KIT GUARNIZIONE MOTORE 224 (3.7L) 470	1
7	REC27-43186A1	27-43186A1	KIT JUNTAS MOTORES 224 (3.7L) CID 165, 170, 180, 190 HP	ENGINE GASKET SET	KIT GUARNIZIONE MOTORE 224 (3.7L) CID 165, 170, 180, 190 HP	1
8	REC26-90925	26-90925	RETÉN TRASERO	ONCE PIECE REAR MAIN SEAL	PARAOILIO POSTERIORE	1
9	REC23-853853002	23-853853002	COJINETES BIELA STD. TODOS LOS MOTORES	ROD BEARING STD. ALL MODELS	BRONZINE DI BIELLA STD. TUTTI I MODELLI	4
9	REC23-853855001	23-853855001	COJINETES BIELA 010 TODOS LOS MOTORES	ROD BEARING 010 ALL MODELS	BRONZINE DI BIELLA 0.10 TUTTI I MODELLI	4
10	REC39-74381A1	39-74381A1	AROS PISTON STD. TODOS LOS MOTORES	PISTON RINGS STD. ALL MODELS	FASCE PISTONE STD. TUTTI I MODELLI	4
10	REC39-75423	39-75423	AROS PISTON 030 TODOS LOS MOTORES	PISTON RINGS 030 ALL MODELS	FASCE PISTONE 0.30 TUTTI I MODELLI	4
11	REC3853847	56153	LIFTER	TAPPET	LIFTER	8
12	REC26-75624	26-75624	RETÉN VÁLVULA	VALVE STEM SEAL	PARAOILIO VALVOLA	8
13	REC26-67388	26-67388	RETÉN DELANTERO CIGÜEÑAL	FRONT CRANKSHAFT SEAL	TENUTA ALBERO MOTORE	1

**JUNTA TAPA VÁLVULAS  
VALVE COVER GASKET  
GUARNIZIONE COPERCHIO PUNTERIE**

Ref.	R.O. OEM
REC27-73666	27-73666

MOTORES / ENGINES / MOTORI  
224 CID (3.7 L)



**JUNTA COLECTOR ESCAPE  
EXHAUST MANIFOLD GASKET  
GUARNIZIONE COLLETTORE SCARICO**

Ref.	R.O. OEM
REC27-68715	27-68715

MOTORES / ENGINES / MOTORI  
460 CID



**JUNTA CULATA  
HEAD GASKET  
GUARNIZIONE TESTATA**

Ref.	R.O. OEM
REC27-13709	27-13709

MOTORES / ENGINES / MOTORI  
224 CID (3.7 L)  
CID Model 470



**JUNTA COLECTOR ADMISIÓN  
INTAKE MANIFOLD GASKET  
GUARN. COLLETTORE ASPIRAZIONE**

Ref.	R.O. OEM
REC27-70905	27-70905

MOTORES / ENGINES / MOTORI  
3.7 L



**COLECTORES, CODOS, TAPAS Y JUNTAS  
MANIFOLDS, ELBOWS, END CAPS & GASKETS  
COLLETTORE, GOMITO, COPERCHIO E GUARNIZIONE**

**120 HP GM 153 4 CYL**

**COLECTOR ESCAPE  
EXHAUST MANIFOLD  
COLLETTORE SCARICO**

Ref.	R.O. OEM
BAMC-1-63122	63122A14 63122A10 63122A13



**JUNTA TAPA COLECTOR  
END CAP GASKET  
GUARNIZIONE COPERCHIO COLLETTORE**

Ref.	R.O. OEM
REC27-39917	27-39917
BAMC47-27-39923	27-39923

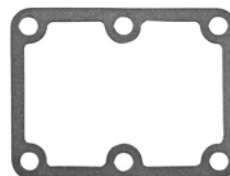

REC27-39917

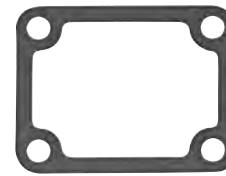

BAMC47-27-39923

**JUNTA COLECTOR  
MANIFOLD GASKET  
GUARNIZIONE COLLETTORE**

Ref.	R.O. OEM
FEL17300	27-52546
REC27-52546	27-52546
REC27-35898T	27-35898T



FEL17300  
REC27-52546

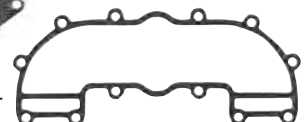

REC27-35898T

**CODO ESCAPE  
ELBOW MANIFOLD  
GOMITO DI SCARICO**

Ref.	R.O. OEM
BAMC-20-55538	55538A2



**TAPA COLECTOR  
END CAP ASSY  
COPERCHIO COLLETTORE**

Ref.	R.O. OEM
BA1-47638	47638A1
HGE4870	73813A1



BA1-47638



HGE4870

**JUNTA CODO  
ELBOW GASKET  
GUARNIZIONE GOMITO**

Ref.	R.O. OEM
REC27-39915	27-39915



140 HP GM 181 4 CYL (1968-82)

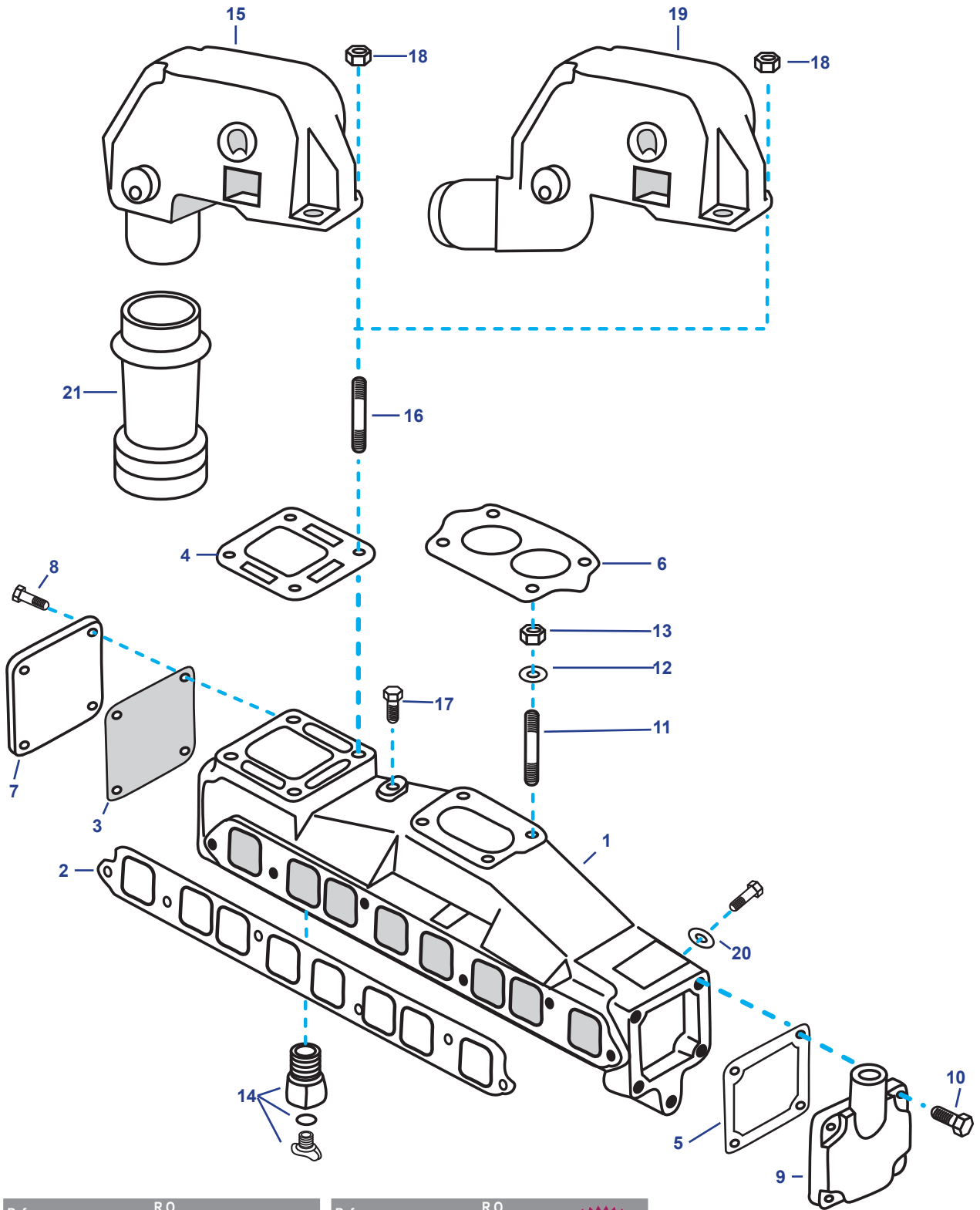

Ref.	R.O. OEM
REC18-8549	
<p>Kit tornillos colector Manifold bolt kit Kit viteria collettore</p>	

Ref.	R.O. OEM
HOT26371-MK	
<p>Kit montaje Mounting kit Kit di montaggio</p>	

**NEW**

Nº	Ref.	R.O. OEM	Descripción	Description	Descrizione	Cantidad Quanty Quantità
1	REC96705A1	96705A1	COLECTOR	EXHAUST MANIFOLD ASSEMBLY	COLLETTORE	1
2	REC27-53354	27-53354	JUNTA COLECTOR	GASKET-EXHAUST MANIFOLD	GUARNIZIONE COLLETTORE	1
2	FEL17301	27-53354	JUNTA COLECTOR	GASKET MANIFOLD	GUARNIZIONE COLLETTORE	1
3	REC27-807218	27-807218	JUNTA TAPA	GASKET END CAP	GUARNIZIONE COPERCHIO	1
4	REC27-99777Q02	27-99777Q02	JUNTA CODO	GASKET EXHAUST MANIFOLD TO ELBOW	GUARNIZIONE INTERMEDIA	1
5	REC27-480431	27-480431	JUNTA TAPA	GASKET END CAP	GUARNIZIONE COPERCHIO	1
6	REC27-64692	27-64692	JUNTA BASE CARB.	GASKET CARBURETOR BASE	GUARNIZIONE BASE CARB.	1
7	HGE4870	73813A1	TAPA COLECTOR	END CAP EXHAUST MANIFOLD	COPERCHIO	1
8	RM10-25299	10-824941	TORNILLO TAPA	SCREW END CAP	VITE COPERCHIO	4
9	REC60252A2	60252A2	TAPA COLECTOR	END CAP EXHAUST MANIFOLD	COPERCHIO COLLETTORE	1
10	REC10-35386	10-35386	TORNILLO TAPA	SCREW END CAP	VITE COPERCHIO	4
11	REC16-70236	16-70236	ESPARRAGO CARBURADOR	STUD CARBURETOR	PRIGIONIERO CARBURATORE	4
12	REC12-20084	12-20084	ARANDELA	WASHER CARBURETOR	RONDELLA	4
13	REC11-862902	11-862902	TUERCA	LOCKNUT CARBURETOR	DADO	4
14	REC13980	22-806608A1	TORNILLO DRENAJE	STRAIGHT FITTING	VITE DI DRENAGGIO	1
<b>NEW</b> 15	HOT20971	76351A04	CODO ESCAPE 3"	EXHAUST ELBOW ASSEMBLY 3"	GOMITO DI SCARICO	1
16	REC16-49545	16-49545	ESPARRAGO CODO	STUD	PRIGIONIERO	4
17	REC22-36382	22-36382	TAPON	PLUG	TAPPO	1
18	REC46335	46335	TUERCA	FLANGE SERRATED NUT	DADO	4
<b>NEW</b> 19	HOT20978	76771A2	CODO ESCAPE 3"	EXHAUST ELBOW ASSEMBLY 3"	GOMITO DI SCARICO 3"	1
19	REC76771A2	76771A2	CODO ESCAPE 3"	EXHAUST ELBOW ASSEMBLY 3"	GOMITO DI SCARICO 3"	1
20	REC21-20553	21-20553	ARANDELLA	WASHER	RONDELLA	6
21	REC53114A1	53114A1	FUELLE ESCAPE	EXHAUST BELLOW	CUFFIA DI SCARICO	1



# 2.5L GM 153 4 CYL / 3.0L 4 CYL (1983-89)

MODELO ANTIGUO  
OLD STYLE OPTION  
MODELLO VECCHIO

MODELO MODERNO  
NEW STYLE OPTION  
MODELLO MODERNO

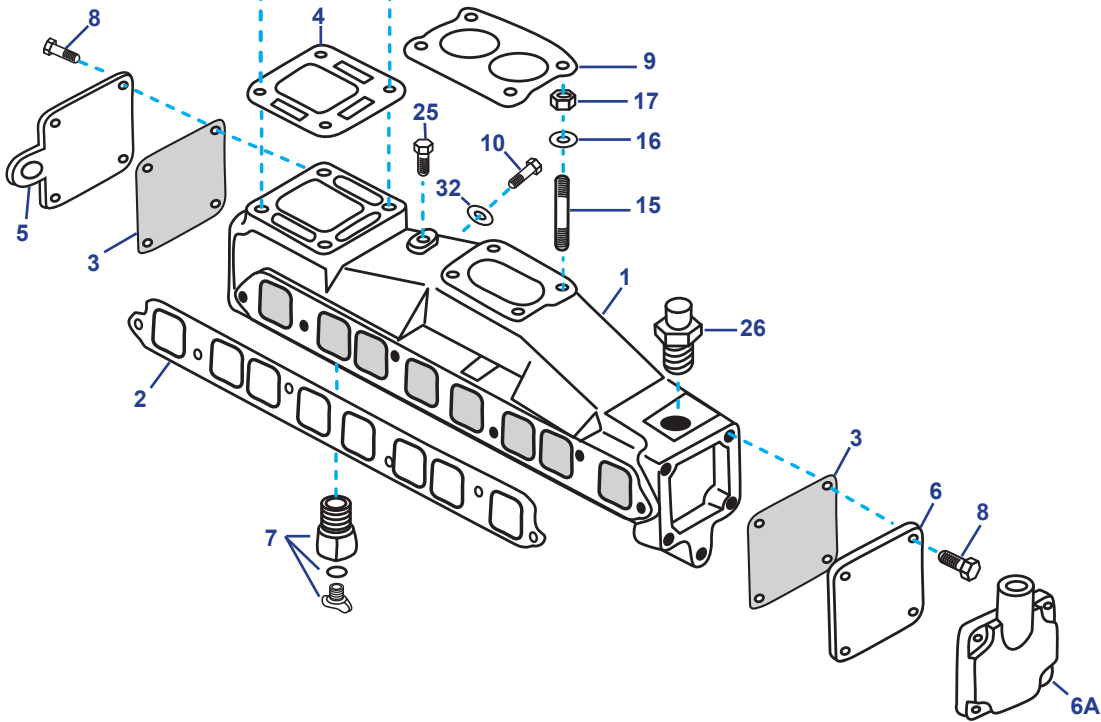
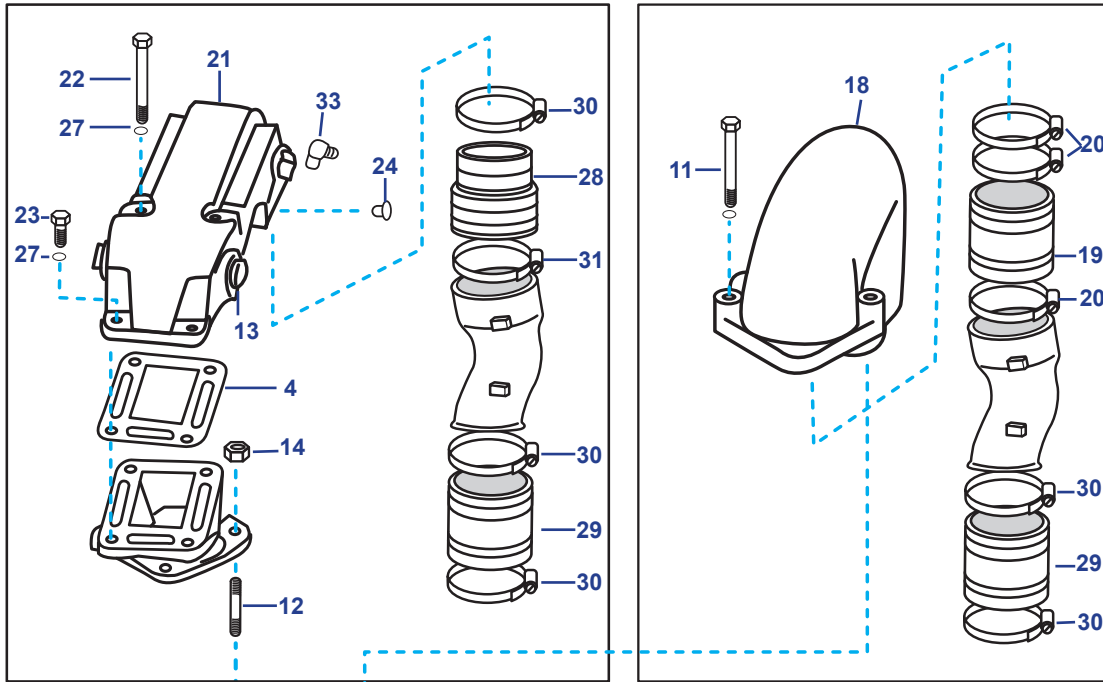

Ref.	R.O. OEM
RECK6325	
<p>Kit tornillos codo y junta Elbow gasket &amp; bolt kit Kit viteria e guanizione gomito</p>	

Ref.	R.O. OEM
HOT20956-MK	
<p><b>NEW</b></p> <p>Kit montaje colector HOT20956 Mounting kit manifold HOT20956 Kit di montaggio collettore HOT20956</p>	

Ref.	R.O. OEM
HOT20975-MK	
<p><b>NEW</b></p> <p>Kit montaje codo HOT20975 Mounting kit elbow HOT20975 Kit di montaggio gomito HOT20975</p>	

NEW

NEW

Nº	Ref.	R.O. OEM	Descripción	Description	Descrizione	Cantidad Quantity Quantità
1	BAMC-1-95862	95862A5	COLECTOR	EXHAUST MANIFOLD CARB. ROCHESTER	COLLETTORE	1
1	HOT20956	860235A04	COLECTOR	EXHAUST MANIFOLD CARB. MERCAB	COLLETTORE	1
1	HOT20956	860235A04	COLECTOR	EXHAUST MANIFOLD CARB.	COLLETTORE	1
2	REC27-96429	27-96429	JUNTA	GASKET EXHAUST MANIFOLD	GUARNIZIONE SCARICO	1
3	REC27-807218	27-807218	JUNTA	GASKET END CAP	GUARNIZIONE COPERCHIO COLLETTORE	2
4	REC27-99777Q02	27-99777Q02	JUNTA	GASKET EXHAUST MANIFOLD TO ELBOW OR ADAPTOR	GUARNIZIONE RISER	2
5	REC805629A1	805629A1	TAPA	END CAP EXHAUST MANIFOLD	COPERCHIO COLLETTORE	1
6	HGE4870	73813A1	TAPA	END CAP - EXHAUST MANIFOLD	COPERCHIO COLLETTORE	1
6A	REC60252A2	60252A2	TAPA COLECTOR	MANIFOLD CAP	COPERCHIO COLLETTORE	1
7	REC13980	22-806608A1	TORNILLERIA	STRAIGHT FITTING	VITERIA	1
8	RM10-25299	10-824941	TORNILLO	SCREW END CAP TO EXHAUST MANIFOLD	VITE	8
9	REC27-8079821	27-8079821	JUNTA (MERCAB)	GASKET CARBURETOR BASE (MERCAB)	GUARNIZIONE CARBURATORE (MERCAB)	1
9	REC27-64692	27-64692	JUNTA (ROCHESTER)	GASKET CARBURETOR BASE (ROCHESTER)	GUARNIZIONE CARBURATORE (ROCHESTER)	1
10	REC10-53728	10-53728	TORNILLO	SCREW (NEW DESIGN)	VITE	3
11	REC10-668631	10-668631	TORNILLO	SCREW	VITE	2
12	REC16-56826	16-56826	ESPARRAGO	STUD	PRIGIONIERO	4
13	REC22-41622	22-41622	TAPON	PLUG EXHAUST ELBOW	TAPPO	4
14	REC46335	46335	TUERCA	FLANGE SERRATED NUT	DADO	4
15	REC16-70236	16-70236	ESPARRAGO	STUD CARBURETOR	PRIGIONIERO	4
16	REC12-20084	12-20084	ARANDELA	WASHER CARBURETOR	RONDELLA	4
17	REC11-862902	11-862902	CIERRE	LOCK NUT CARBURETOR	CHIUSURA	4
18	MAR076	12076A2	CODO	EXHAUST ELBOW ASSEMBLY	GOMITO	1
18	SED3092610	12076A2	CODO ESCAPE INOX	STAINLESS STEEL EXHAUST ELBOW	GOMITO SCARICO INOX	1
18	HOT20975	12076A2	CODO	EXHAUST ELBOW ASSEMBLY	GOMITO	1
19	REC32-44348001	32-44348001	FUELLE	EXHAUST BELLOW EXHAUST ELBOW 4"	CUFFIA	1
20	GS38320	54-815504372	ABRAZADERA 4"	CLAMP BELLOW 4"	FASCETTA 4"	2
21	REC76325A2	76325A2	CODO	EXHAUST ELBOW ASSEMBLY	GOMITO	1
22	REC10-72094	10-72094	TORNILLO	SCREW EXHAUST ELBOW	VITE	2
23	REC10-34354	10-34354	TORNILLO	SCREW EXHAUST ELBOW	VITE	2
24	REC22-328022	22-328022	TAPÓN	PLUG	TAPPO	1
25	REC22-36382	22-36382	TAPÓN	PLUG	TAPPO	1
26	REC22-866725	22-866725	ENTRONQUE 3/4-14x1 (LATÓN)	STRAIGHT FITTING 3/4-14 x 1 (BRASS)	RACCORDO 3/4-14x1 (OTTONE)	1
27	REC13-35048	13-35048	ARANDELA	LOCKWASHER	RONDELLA	4
28	REC70981A3	70981A3	FUELLE	EXHAUST BELLOW (USE WITH 2-PIECE EXHAUST ELBOW)	CUFFIA	1
29	REC32-90949T	32-90949T	FUELLE	EXHAUST TUBE	CUFFIA	1
30	GS38320	54-815504256	ABRAZADERA	HOSE CLAMP	FASCETTA	3
31	GS38322	54-815504372	ABRAZADERA	HOSE CLAMP	FASCETTA	1
32	REC21-20553	21-20553	ABRAZADERA	WASHER	FASCETTA	2
33	REC13960		CODO	ELBOW FITTING	GOMITO	1
34	REC13-35048	13-35048	ARANDELA	WASHER	RONDELLA	4

Para determinar el tipo de carburador (Rochester / Mercab) ver medida de junta:  
To determine the type of carburetor (Rochester / Mercab) see joint measurement:  
Per determinare il tipo di carburatore (Rochester / Mercab) vedi misurazione di guarnizione:

# 3.0L & 3.0LX GM 181 4 CYL (1990+)

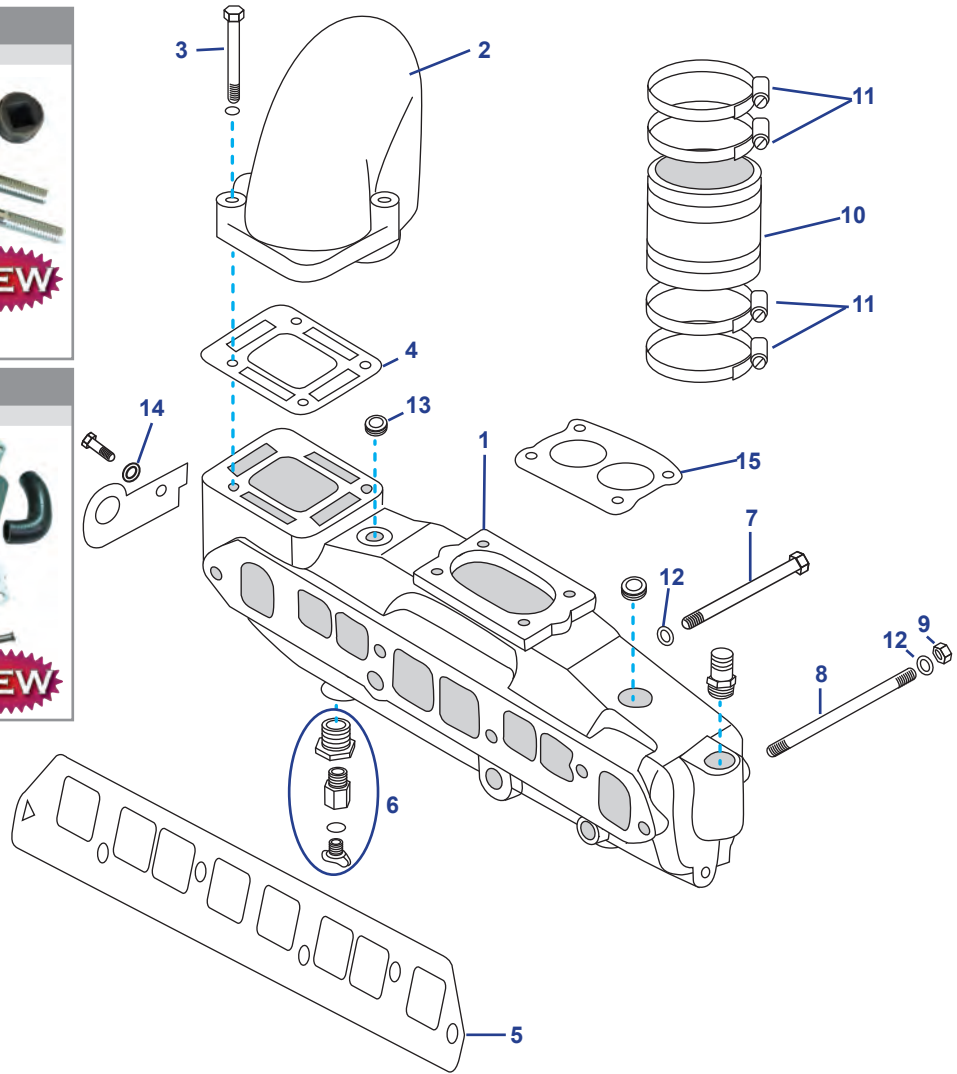

Nº	Ref.	R.O. OEM	Descripción	Description	Descrizione	Cantidad Quantity Quantità
1	BAMC-1-860235	860235A03	COLECTOR Sustituye al 806867A12	EXHAUST MANIFOLD Replaces 806867A12	COLLETTORE Sostituisce 806867A12	1
<b>NEW</b>	HOT20966	860235A03	COLECTOR ESCAPE	EXHAUST MANIFOLD	COLLETTORE DI SCARICO	1
2	MAR076	12076A2	CODO ESCAPE	EXHAUST ELBOW	GOMITO DI SCARICO	1
<b>NEW</b>	HOT20975	12076A2	CODO ESCAPE	EXHAUST ELBOW	GOMITO DI SCARICO	1
2	SED3092610	12076A2	CODO ESCAPE INOX	EXHAUST ELBOW STAINLESS STEEL	GOMITO DI SCARICO INOX	1
3	REC10-668631	10-668631	TORNILLO	SCREW	VITE	2
4	REC27-99777Q02	27-99777Q02	JUNTA CODO	GASKET EXHAUST MANIFOLD TO ELBOW	GUARNIZIONE COLLETTORE / GOMITO	1
5	REC27-815528	27-815528	JUNTA COLECTOR	GASKET EXHAUST MANIFOLD	GUARNIZIONE COLLETTORE	1
5	FEL17304	27-815528	JUNTA COLECTOR	GASKET EXHAUST MANIFOLD	GUARNIZIONE COLLETTORE	1
6	REC13980	22-806608A1	TORNILLERÍA	STRAIGHT WATER DRAINING	VITERIA	1
7	REC10-53728	10-53728	TORNILLO	SCREW	VITE	2
8	REC16-806300	16-806300	ESPARRAGO	STUD	PRIGIONIERO	3
9	REC46335	46335	TUERCA	FLANGE SERRATED NUT	DADO	3
10	REC32-44348001	32-44348001	FUELLE CODO ESCAPE	EXHAUST BELLOW 4"	CUFFIA GOMITO DI SCARICO	1
11	GS38320	54-815504256	ABRAZADERA FUELLE	CLAMP 4"	FASCETTA	2
12	REC21-20553	21-20553	ARANDELA	WASHER	RONDELLA	5
13	REC22-32803	22-32803	TAPÓN	CAP	TAPPO	1
14	REC12-20084	12-20084	ARANDELA	WASHER	RONDELLA	1
15	REC27-8079821	27-8079821	JUNTA CARBURADOR MERCAB (NO TKS)	CARBURATOR GASKET MERCAB (NO TKS)	GUARNIZIONE CARBURATORE MERCAB (NO TKS)	1

# 165, 170, 180, 190, 470, 485, 488 3.7L & 3.7LX MCM 224 CID 4 CYL (1980-89)

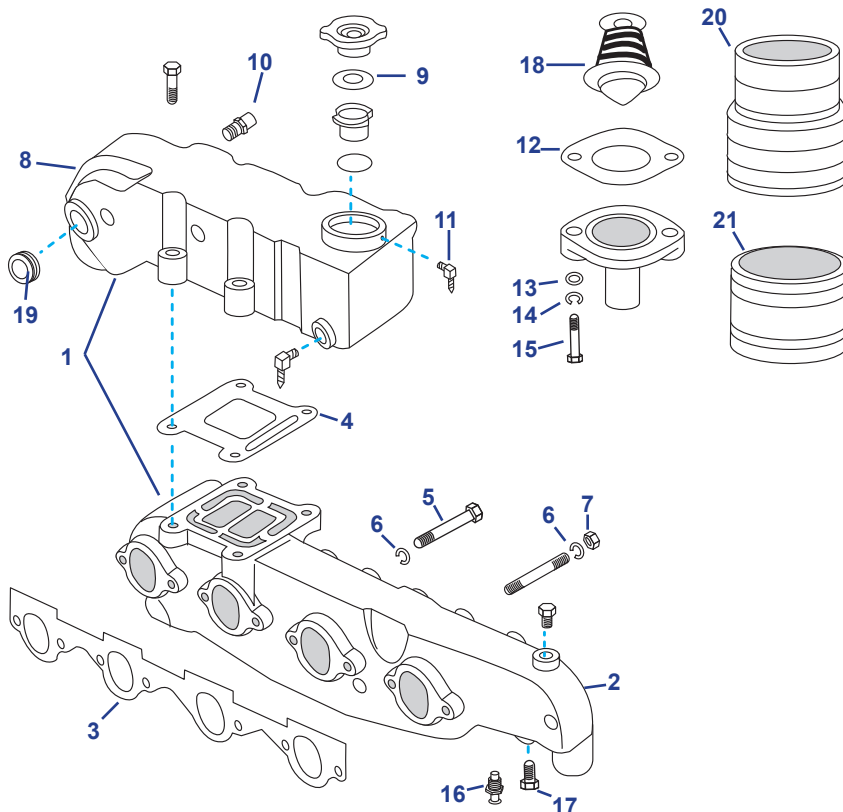

Ref. R.O. OEM  
**RECK0879**  
Kit para colector de fundición  
Kit for cast iron manifold  
Kit viteria per collettori in ghisa

Ref. R.O. OEM  
**HOT20905-MK**

Kit montaje codo HOT20905  
Mounting kit elbow HOT20905  
Kit di montaggio gomito HOT20905

**NEW**

Ref. R.O. OEM  
**HOT20937-MK**

Kit montaje codo HOT20937  
Mounting kit elbow HOT20937  
Kit di montaggio gomito HOT20937

**NEW**

**NEW**  
**NEW**

Nº	Ref.	R.O. OEM	Descripción	Description	Descrizione	Cantidad Qty Quantità
1	RM816219A4	816219A4	KIT CODO/COLECTOR	EXHAUST ELBOW/MANIFOLD	KIT COLLETTORE+GOMITO	1
2	HGE6219-A	816219A5	COLECTOR ALUMINIO	EXHAUST MANIFOLD (ALUM )	COLLETTORE IN ALLUMINIO	1
3	REC27-68715	27-68715	JUNTA COLECTOR ESCAPE	GASKET - EXHAUST MANIFOLD	GUARNIZIONE COLLETTORE SCARICO	1
4	REC27-18272	27-18272	JUNTA CODO A COLECTOR	GASKET - ELBOW TO MANIFOLD	GUARNIZIONE COLLETTORE GOMITO	1
4	REC27-856705	27-856705	JUNTA COLECTOR DE HIERRO	GASKET FOR IRON MANIFOLD	GUARNIZIONE PER COLLETTORE IN GHISA	1
5	REC22-73379	10-74727	TORNILLO	SCREW	VITE	3
6	REC13-35048	13-35048	CIERRE	LOCKWASHER	RONDELLA	3
7	REC46335	46335	TUERCA	FLANGE SERRATED NUT	DADO	1
8	HOT20937	98562A6	CODO PARA COLECTOR ALUMINIO	EXHAUST ELBOW FOR ALUM. MANIFOLD	GOMITO PER COLLETTORI IN ALLUMINO	1
8	HOT20905	90880A2	CODO PARA COLECTOR HIERRO	ELBOW FOR CAST. MANIFOLD	GOMITO PER COLLETTORI IN GHISA	1
9		27-71614	JUNTA TAPA	GASKET FILLER CAP	GUARNIZIONE	1
10	REC22-866725	22-866725	RACOR COLECTOR	HOSE FITTING	RACCORDO COLLETTORE	1
11	REC22-76170	22-76170	RACOR CODO 90°	ELBOW FITTING 90°	RACCORDO GOMITO 90°	1
12	REC27-89656-1	27-896561	JUNTA	GASKET	GUARNIZIONE	1
13		12-26825	ARANDELA	WASHER	RONDELLA	2
14	REC13-39107	13-39107	CIERRE	LOCKWASHER	CHIUSURA	2
15	REC10-73657	10-73657	TORNILLO	SCREW	VITE	2
16	REC15995	15995	SENSOR TEMPERATURA	TEMPERATURE SENDER	SENSORE TEMPERATURA	1
17	REC22-32803	22-32803	TAPÓN	PLUG	TAPPO	1
18	REC99155T2	99155T2	TERMOSTATO	THERMOSTAT	TERMOSTATO	1
19	REC22-428611	22-428611	TAPÓN	CAP	TAPPO	1
20	REC70981A3	70981A3	FUELLE ESCAPE	EXHAUST BELLOW	CUFFIA SCARICO	1
21	REC32-90949T	32-90949T	FUELLE ESCAPE	EXHAUST BELLOW	CUFFIA SCARICO	1

GM 160 - 165 - 200CID - 250 - 292CID  
6 CYL EN LÍNEA / IN LINE / IN LINIA

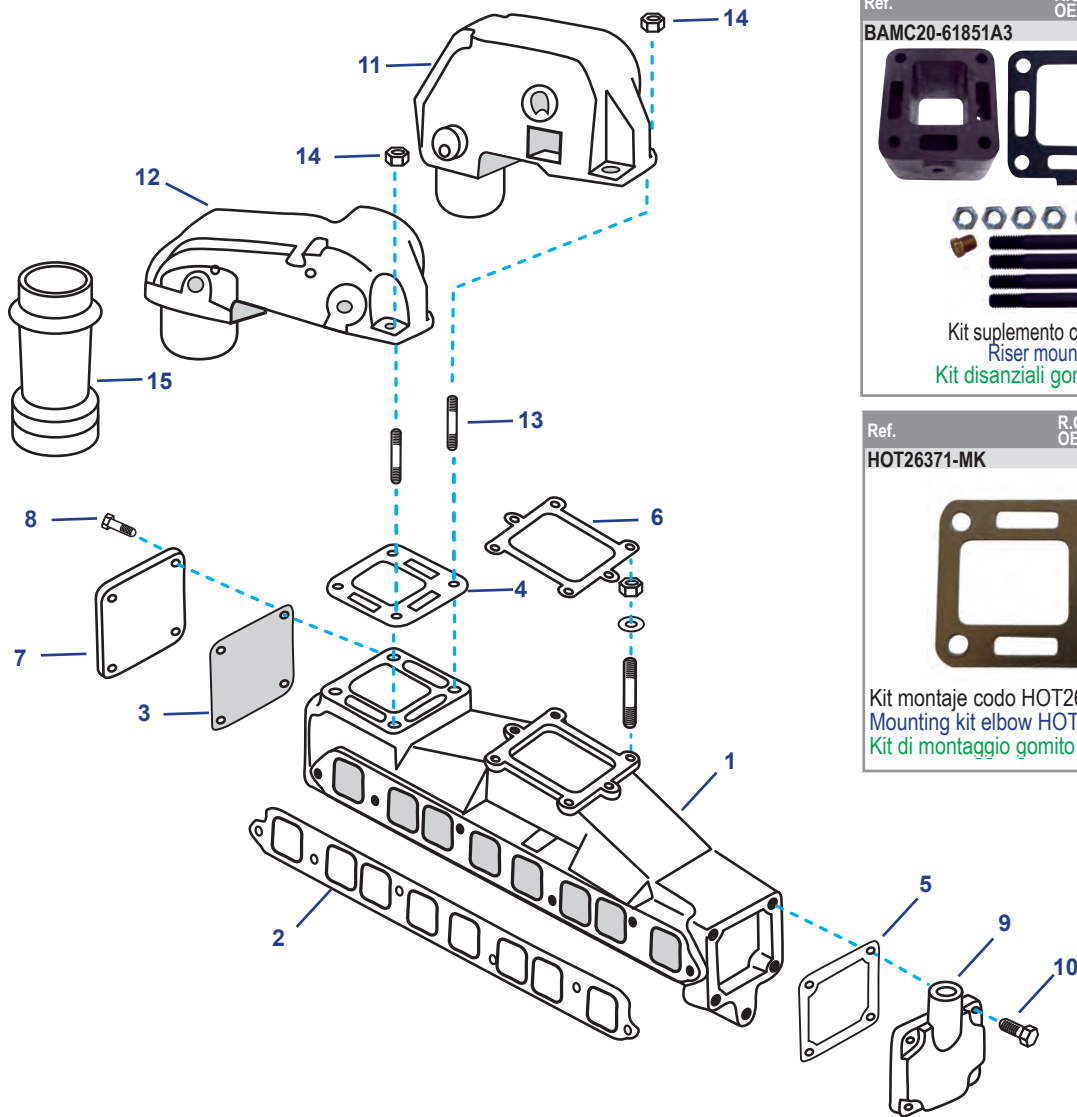

Nº	Ref.	R.O. OEM	Descripción	Description	Descrizione	Cantidad Qty Quantità
1	BAMC-1-58759	58759A14	COLECTOR ESCAPE	EXHAUST MANIFOLD ASSEMBLY	COLLETTORE SCARICO	1
2	FEL17319	27-46401	JUNTA COLECTOR ADM/ ESCAPE	GASKET INT./EXHAUST MANIFOLD	GUARNIZIONE COLLETTORE ASP/SCARICO	1
3	REC27-807218	27-807218	JUNTA TAPA	GASKET END CAP	GUARNIZIONE COPERCHIO	1
4	REC27-99777Q02	27-99777Q02	JUNTA COLECTOR A CODO	GASKET EXHAUST MANIFOLD TO ELBOW	GUARNIZIONE INTERMEDIA	1
5	REC27-480431	27-480431	JUNTA TAPA	GASKET END CAP	GUARNIZIONE COPERCHIO	1
6	REC27-58764	27-58764	JUNTA CARBURADOR	GASKET CARBURETOR	GUARNIZIONE CARBURATORE	1
7	HGE4870	73813A1	TAPA	END CAP EXHAUST MANIFOLD	COPERCHIO	1
8	RM10-25299	10-824941	TORNILLO	SCREW END CAP	VITE	4
9	REC60252A2	60252A2	TAPA COLECTOR	END CAP EXHAUST MANIFOLD	COPERCHIO	1
10	REC10-37562	10-37562	TORNILLO	SCREW	VITE	4
<b>NEW</b>	HOT20971	76351A04	CODO 90° 3"	EXHAUST ELBOW ASSEMBLY 3" 90° ANGLE	GOMITO DI SCARICO 90° 3"	1
12	REC76325A2	76325A2	CODO 90° 3"	EXHAUST ELBOW ASSEMBLY 3" 90° ANGLE	GOMITO DI SCARICO 90° 3"	1
13	REC16-49545	16-49545	ESPÁRRAGO	STUD	PRIGIONIERO	4
14	REC46335	46335	TUERCA	NUT	DADO	4
15	REC53114A1	53114A1	FUELLE ESCAPE	EXHAUST BELLOW	CUFFIA DI SCARICO	1

# 262 MAG (TBI), 4.3L (GEN+), 4.3 L EFI (GEN+), 4.3 LH (GEN+), 4.3LX (GEN+), GM 262 V6 (1996-01)



PIEZAS NECESARIAS PARA SUBSTITUIR EL COLECTOR-CODO PARA V6.  
NEEDS PARTS TO REPLACE V6 MANIFOLD-ELBOW.  
PEZZI NECESSARI PER SOSTITUIRE IL COLLETTORE PER V6.



1



6



2



7



3



4



8



5

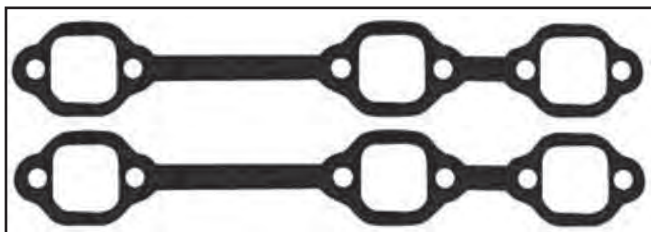

9



10

Nº	Ref.	R.O. OEM	Descripción	Description	Descrizione	Cantidad Qty Quantità
1	MAR746	99746A17	COLECTOR	MANIFOLD	COLLETTORE	2
1	HOT20952	99746A17	COLECTOR	MANIFOLD	COLLETTORE	2
2	MAR988	807988A03	CODO 4"	ELBOW 4"	GOMITO 4"	2
2	HOT20976	807988A03	CODO 4"	ELBOW 4"	GOMITO 4"	2
3	REC32-44348001	32-44348001	FUELLE ESCAPE SUPERIOR	UPPER EXHAUST BELLOW	CUFFIA SCARICO SUPERIORE	2
4	REC32-14358001	32-14358001	FUELLE ESCAPE INFERIOR	LOWER EXHAUST BELLOW	CUFFIA SCARICO INFERIORE	2
5	BAMC-20-14478	14478T01	CURVA ESCAPE V6	EXHAUST ELBOW ASSY	CURVA SCARICO V6	2
6	GS38322	54-815504372	ABRAZADERA INOX	INOX CLAMP	FASCETTA INOX	8
7	REC32175		KIT JUNTA Y TORNILLOS	GASKETS & BOLTS KIT	KIT VITERIA E GUARNIZIONI	2
8	REC53400		KIT JUNTAS CODOS Y TORNILLOS	BOLTS & ELBOWS GASKETS KITS	KIT VITERIA E GUARNIZIONI	2
9	FEL17410	27-99757	KIT JUNTAS COLECTOR (2 unidades)	MANIFOLD GASKET KIT (2 units)	KIT GUARNIZIONI (2 unità)	1
9	REC27-99757	27-99757	JUNTA COLECTOR (1 unidad)	MANIFOLD'S GASKET (1 unit)	GUARNIZIONE (1 unità)	2
10	REC862210A01	22-862210A01	KIT TAPÓN Y CONDUCTO	HOSE FITTING W/DRAIN PLUG KIT	KIT RUBINETTO	2

NEW

NEW

175, 185, 205, 262 MAG, 4.3L, 4.3LX, 4.3 LH, 4.3 LXH, 4.3 EFI, 4.3 MPI, GM 262 CID V6

102

MERCURISER

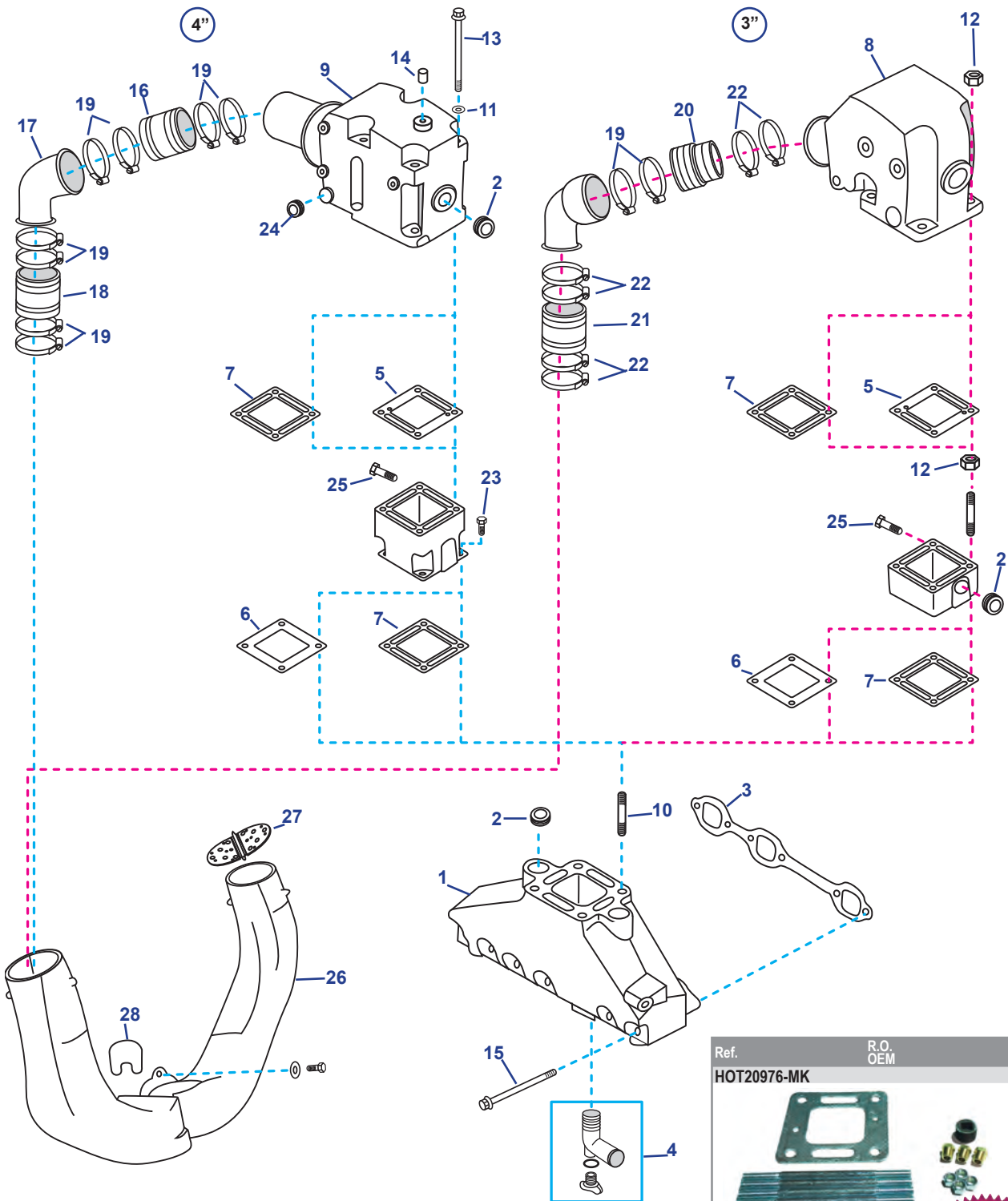

Ref. **RECK8503** R.O. OEM

Kit tornillos codo y junta  
Elbow gasket & bolt kit  
Kit viteria gomito e guarnizione

Ref. **HOT20952-MK** R.O. OEM

Kit montaje para HOT20976  
Mounting kit elbow HOT20976  
Kit di montaggio gomito HOT20976

**NEW**

Ref. **HOT20976-MK** R.O. OEM

Kit montaje para HOT20976  
Mounting kit elbow HOT20976  
Kit di montaggio gomito HOT20976

**NEW**

Ref. **HOT28503-MK** R.O. OEM

Kit montaje para HOT20976  
Mounting kit elbow HOT20976  
Kit di montaggio gomito HOT20976

**NEW**

Nº	Ref.	R.O. OEM	Descripción	Description	Descrizione	Cantidad Qty Quantità
<b>NEW</b> 1	MAR746	99746A17	COLECTOR	MANIFOLD	COLLETTORE	1
1	HOT20952	99746A17	COLECTOR	MANIFOLD	COLLETTORE	1
2	REC22-41622	22-41622	TAPÓN ACERO	PLUG (STEEL)	TAPPO IN ACCIAIO	2
2	REC22-428611	22-428611	TAPÓN BRONCE	PLUG (BRASS)	TAPPO IN BRONZO	2
3	REC27-99757	27-99757	JUNTA COLECTOR	GASKET EXHAUST MANIFOLD	GUARNIZIONE COLLETTORE	1
3	FEL17410	27-99757	KIT DE JUNTAS COLECTOR	GASKET EXHAUST MANIFOLD KIT	KIT GUARNIZIONI COLLETTORE	1
4	REC862210A01	22-862210A01	KIT TAPÓN Y CONDUCTO	HOSE FITTING WITH DRAIN PLUG KIT	KIT TAPPO E CONDOTTO	1
5	REC27-863724Q	27-863724Q	JUNTA COLECTOR CIRCUITO CERRADO	GASKET MANIFOLD FOR RAW WATER COOLING	GUARNIZIONE PER CIRCUITO CHIUSO	1
6	REC27-8637251	27-8637251	JUNTA COLECTOR CIRCUITO AGUA DULCE	GASKET MANIFOLD FOR FRESH WATER COOLING	GUARNIZIONE PER CIRCUITO CHIUSO	1
<b>NEW</b> 7	REC27-863726	27-863726	JUNTA	GASKET MANIFOLD	GUARNIZIONE	1
8	HOT20970	98504A3	CODO	ELBOW 3" 15°	GOMITO	1
8	REC98504A3	98504A3	CODO	ELBOW 3" 15°	GOMITO	1
<b>NEW</b> 9	MAR988	807988A03	CODO	ELBOW 4" 7°	GOMITO	1
9	HOT20976	807988A03	CODO	ELBOW	GOMITO	1
9	SED3092600	807988A3	CODO INOX	ELBOW INOX	GOMITO INOX	1
10	REC16-49545	16-49545	ESPARRAGO DE ACERO	STUD (STEEL)	PRIGIONIERO IN ACCIAIO	4
11	REC13-35048	13-35048	ARANDELA CIERRE	LOCKWASHER	CHIUSURA	4
12	REC46335	46335	TUERCA CODO	NUT FLANGE SERRATED NUT	DADO GOMITO	4
13	REC10-43749	10-43749	TORNILLO	SCREW	VITE	4
14	REC22-73379	22-73379	TAPÓN	PLUG	TAPPO	1
15	REC10-53728	10-53728	TORNILLO	SCREW	VITE	6
16	REC32-44348001	32-44348001	FUELLE ESCAPE 4"	EXHAUST BELLOW 4"	CUFFIA DI SCARICO 4"	1
17	BAMC-20-14478	14478T01	TUBO 4"	TUBE 4"	TUBO 4"	1
17	RM14865A1	14865A1	KIT INSTALACIÓN RISER V6	V6 RISER INST. ASSEMBLY	KIT INSTALACION RISER V6	1
18	REC32-14358001	32-14358001	FUELLE ESCAPE	EXHAUST BELLOW	CUFFIA DI SCARICO	1
19	GS38322	54-815504372	ABRAZADERA	CLAMP	FASCETTA	8
20	REC70981A3	70981A3	FUELLE ESCAPE 3"	EXHAUST BELLOW 3"	CUFFIA DI SCARICO 3"	1
21	REC32-90949T	32-90949T	FUELLE ESCAPE 3"	EXHAUST BELLOW 3"	CUFFIA DI SCARICO 3"	1
22	GS38320	54-815504256	ABRAZADERA	CLAMP	FASCETTA	6
23	REC10-865982005	10-865982005	TORNILLO	SCREW	VITE	4
24	REC22-36382	22-36382	TAPÓN	PLUG	TAPPO	1
25	REC22-328022	22-328022	TAPÓN	PLUG	TAPPO	1
26	RM807130A4	807130A4	CUERNOS DE ESCAPE	EXHAUST PIPE	CORNA DI SCARICO	1
27	REC807166A1	807166A1	PALOMILLA ESCAPE	WATER SHUTTER	FARFALLA SCARICO	1
28	REC41802	41802	JUNTA	GASKET	GUARNIZIONE	1

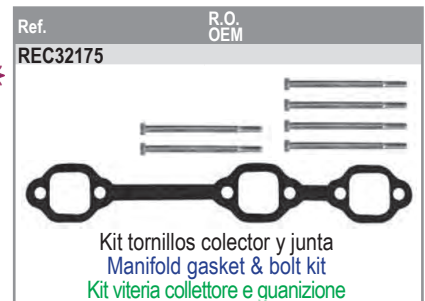
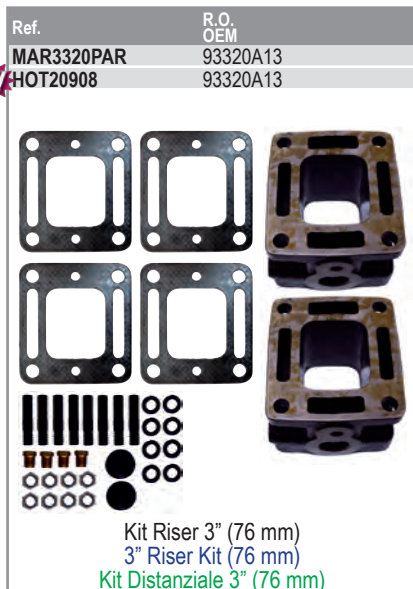



# 4.3L CARB MPI ALPHA/BRAVO

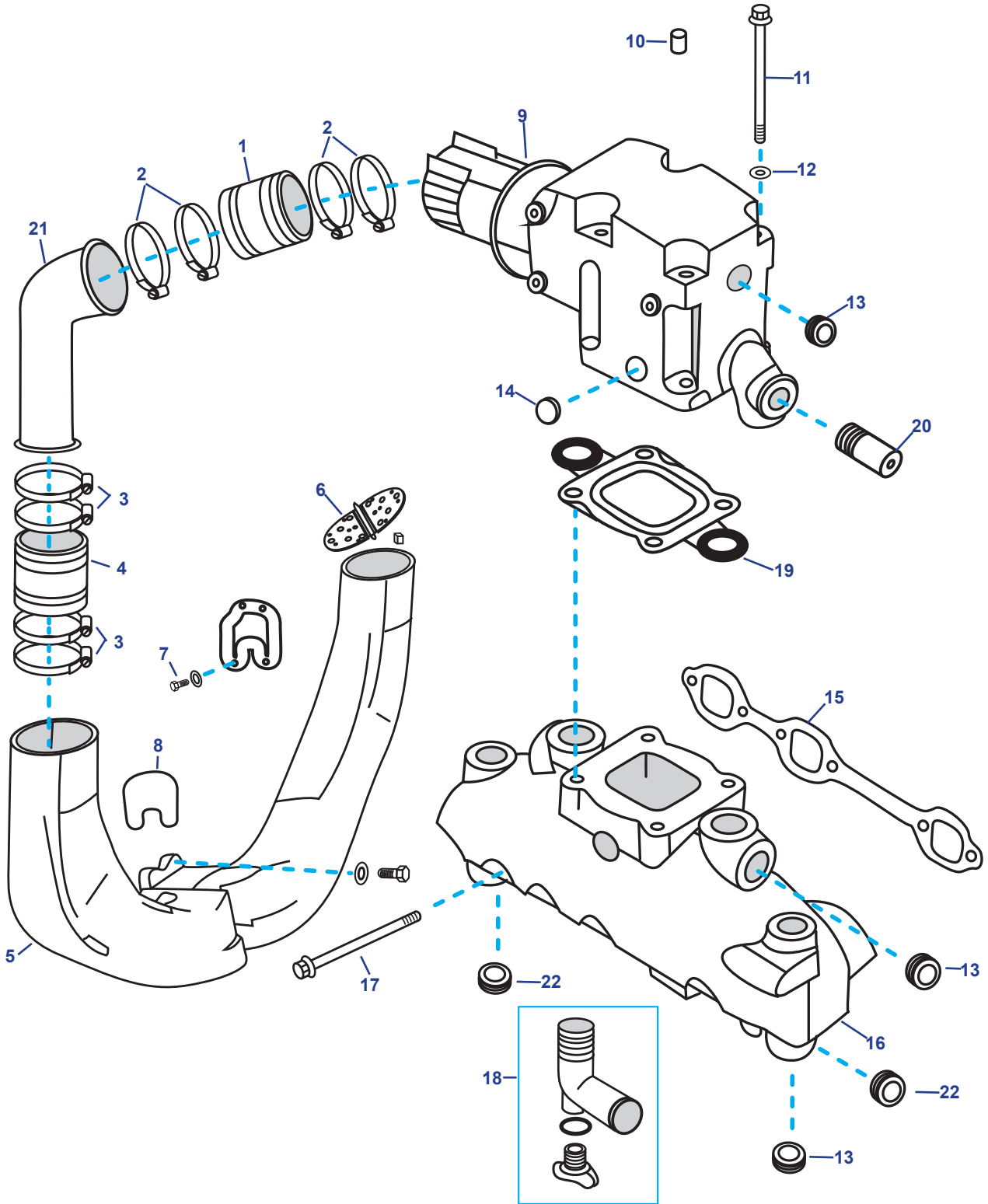

Ref.	R.O. OEM	
BAMC-20-864908A1	864908A1	6"
KIT RISER 6"		

Ref.	R.O. OEM	
RECK309		
Kit tornillos codo y junta Elbow gasket & bolt kit Kit viteria gomito e guarnizione		

Ref.	R.O. OEM	
REC270		
Junta codo - colector Elbow - manifold gasket Guarnizione intermedia		

NEW

Nº	Ref.	R.O. OEM	Descripción	Description	Descrizione	Cantidad Quanty Quantità
1	REC32-44348001	32-44348001	FUELLE ESCAPE	EXHAUST BELLOW	MANICOTTO SCARICO	2
2	GS38310	54-815504456	ABRAZADERA	CLAMP	FASCETTA	8
3	GS38320	54-815504456	ABRAZADERA	CLAMP	FASCETTA	8
4	REC32-14358001	32-14358001	FUELLE ESCAPE COLECTOR	EXHAUST BELLOW	MANICOTTO SCARICO COLLETTORE	2
5	RM807130A4	807130A4	CUERNOS DE ESCAPE	EXHAUST PIPE	CORNA DI SCARICO	1
6	REC807166A1	807166A1	PALOMILLA ESCAPE	WATER SHUTTER	FARFALLA SCARICO	2
7	REC10-98794	10-98794	TORNILLO	SCREW COVER	VITE	4
8	REC41802	41802	RETÉN TRANSON	TRANSON GASKET	GUARNIZIONE TRANSON	1
9	MAR309	864309T02	CODO BAJO 17 cm	ELBOW LOW 17 cm	GOMITO BASSO 17 cm	2
9	MAR591	864591T02	CODO ALTO 20,5 cm	ELBOW HIGH 20,5 cm	GOMITO ALTO 20,5 cm	2
9	HOT20591	864591T02	CODO ALTO 20,5 cm	ELBOW HIGH 20,5 cm	GOMITO ALTO 20,5 cm	2
9	SED3095400	864309T02	CODO BAJO INOX	ELBOW LOW SS	GOMITO BASSO INOX	2
9	SED3095500	864591T02	CODO ALTO INOX	ELBOW HIGH SS	GOMITO ALTO INOX	2
10	REC22-73379	22-73379	TAPÓN	PLUG	TAPPO	1
11	REC10-43749	10-43749	TORNILLO	SCREW	VITE	8
12	REC13-35048	13-35048	ARANDELA	LOCK WASHER	RONDELLA	8
13	REC22-428611	22-428611	TAPÓN	FITTING	TAPPO	8
14	REC19-864689	19-864689	TAPÓN	PLUG	TAPPO	2
15	REC27-99757	27-99757	JUNTA COLECTOR	MANIFOLD GASKET	GUARNIZIONE COLLETTORE	2
15	FEL17410	27-99757	KIT JUNTAS COLECTOR	MANIFOLD GASKET KIT	KIT GUARNIZIONE COLLETTORE	1
16	MAR612	864612T01	COLECTOR	MANIFOLD	COLLETTORE	2
17	REC10-53728	10-53728	TORNILLO	SCREW	VITE	6
18	REC862210A01	22-862210A01	KIT TAPÓN Y CONDUCTO	ELBOW AND PLUG KIT	KIT TAPPO E TUBO	1
19	REC270	27-684547A02	JUNTA CODO - COLECTOR	ELOW-MANIFOLD GASKET	GUARNIZIONE INTERMEDIA	1
20	REC22-866725	22-866725	RACORD COLECTOR	STRAIGHT FITTING	RACCORDO COLLETTORE	1
21	RM14865A1	14865A1	KIT RISER V6	RISER KIT V6	KIT RISER V6	1
22	PAF15-07010004	479452	TAPÓN 1/8"	PLUG 1/8"	TAPPO 1/8"	1

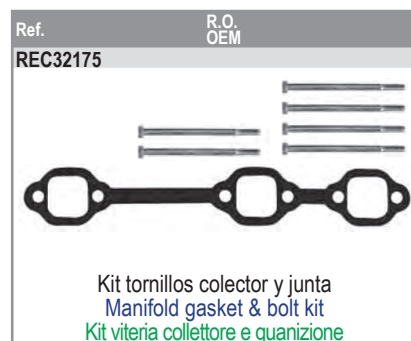
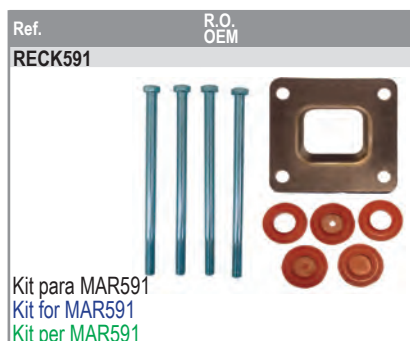
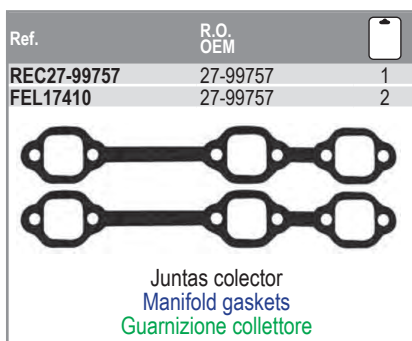
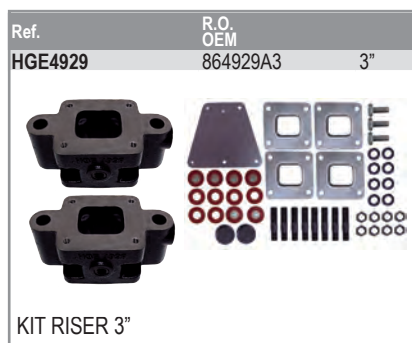

# 305, 350, 377, 383, 385, (6.2L) MAG MPI HORIZON ALPHA/BRAVO

MERCURISER

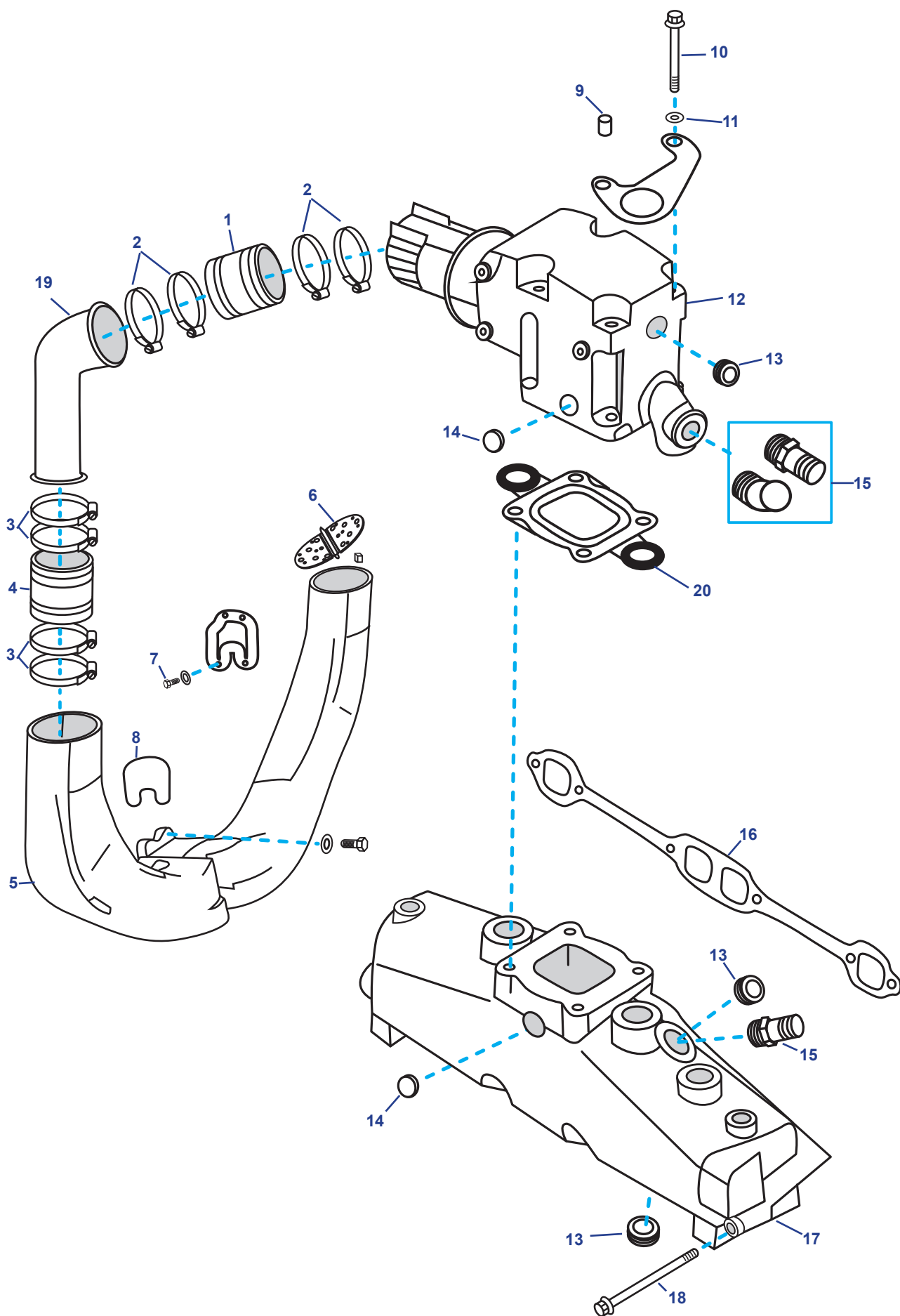

Nº	Ref.	R.O. OEM	Descripción	Description	Descrizione	Cantidad Quantity Quantità
1	REC32-44348001	32-44348001	FUELLE ESCAPE	EXHAUST BELLOW	MANICOTTO SCARICO	2
2	GS38310	54-815504456	ABRAZADERA	CLAMP	FASCETTA	8
3	GS38320	54-815504272	ABRAZADERA	CLAMP	FASCETTA	8
4	REC32-14358001	32-14358001	FUELLE ESCAPE COLECTOR	EXHAUST BELLOW	MANICOTTO SCARICO COLLETTORE	2
5	RM807130A4	807130A4	CUERNOS DE ESCAPE	EXHAUST PIPE	CORNA DI SCARICO	1
6	REC807166A1	807166A1	PALOMILLA ESCAPE	WATER SHUTTER	FARFALLA SCARICO	2
7	REC10-98794	10-98794	TORNILLO	SCREW COVER	VITE	4
8	REC41802	41802	RETÉN TRANSON	TRANSON GASKET	GUARNIZIONE TRANSON	1
9	REC22-73379	22-73379	TAPÓN	PLUG	TAPPO	1
10	REC10-43749	10-43749	TORNILLO	SCREW	VITE	8
11	REC13-35048	13-35048	ARANDELA	WASHER	RONDELLA	8
12	MAR309	864309T02	CODO BAJO 17 cm	ELBOW LOW 17 cm	GOMITO BASSO 17 cm	2
12	MAR591	864591T02	CODO ALTO 20,5 cm	ELBOW HIGH 20,5 cm	GOMITO ALTO 20,5 cm	2
<b>NEW</b>	HOT20951	864591T02	CODO ALTO 20,5 cm	ELBOW HIGH 20,5 cm	GOMITO ALTO 20,5 cm	2
12	SED3095400	864309T02	CODO BAJO INOX	ELBOW LOW SS	GOMITO BASSO INOX	2
12	SED3095500	864591T02	CODO ALTO INOX	ELBOW HIGH SS	GOMITO ALTO INOX	2
13	REC22-428611	22-428611	TAPÓN	PLUG	TAPPO	4
14	REC19-864689	19-864689	TAPÓN	PLUG	TAPPO	6
15	REC22-866725	22-866725	RACORD COLECTOR	STRAIGHT FITTING	RACCORDO COLLETTORE	1
16	REC27-33395	27-33395	JUNTA COLECTOR	MANIFOLD GASKET	GUARNIZIONE COLLETTORE	2
16	FEL17420	27-33395	KIT JUNTAS COLECTOR	MANIFOLD GASKET KIT	KIT GUARNIZIONE COLLETTORE	1
<b>NEW</b>	HOT20735	865735A02	COLECTOR	MANIFOLD	COLLETTORE	2
<b>NEW</b>	MAR735	865735A02	COLECTOR	MANIFOLD	COLLETTORE	2
18	REC10-53728	10-53728	TORNILLO	SCREW	VITE	8
19	RM14801A1	14801A1	KIT SUPLEMENTOS	KIT RISER	KIT DISTANZIALE	1
20	REC270		JUNTA CODO - COLECTOR	ELBOW-MANIFOLD GASKET	GUARNIZIONE INTERMEDIA	1

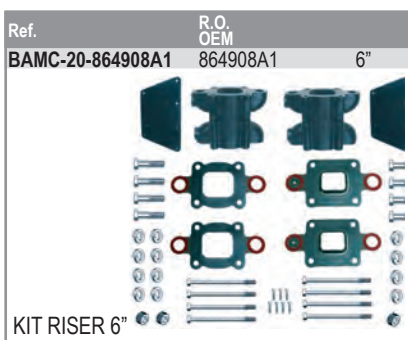
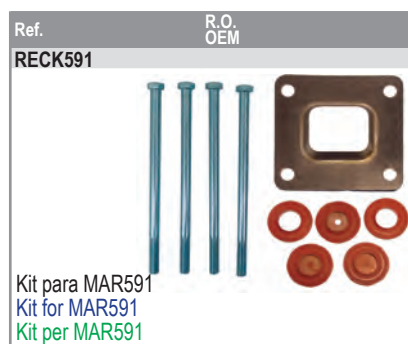
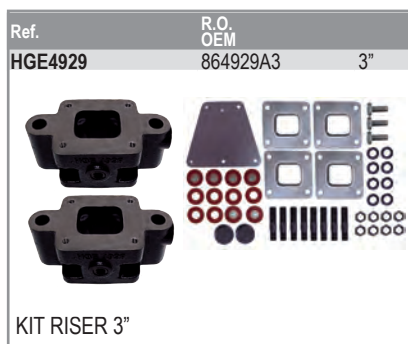

198MIE, 228, 228MIE & 898, GM305CID,  
V8 / 250, 255MIE & 260

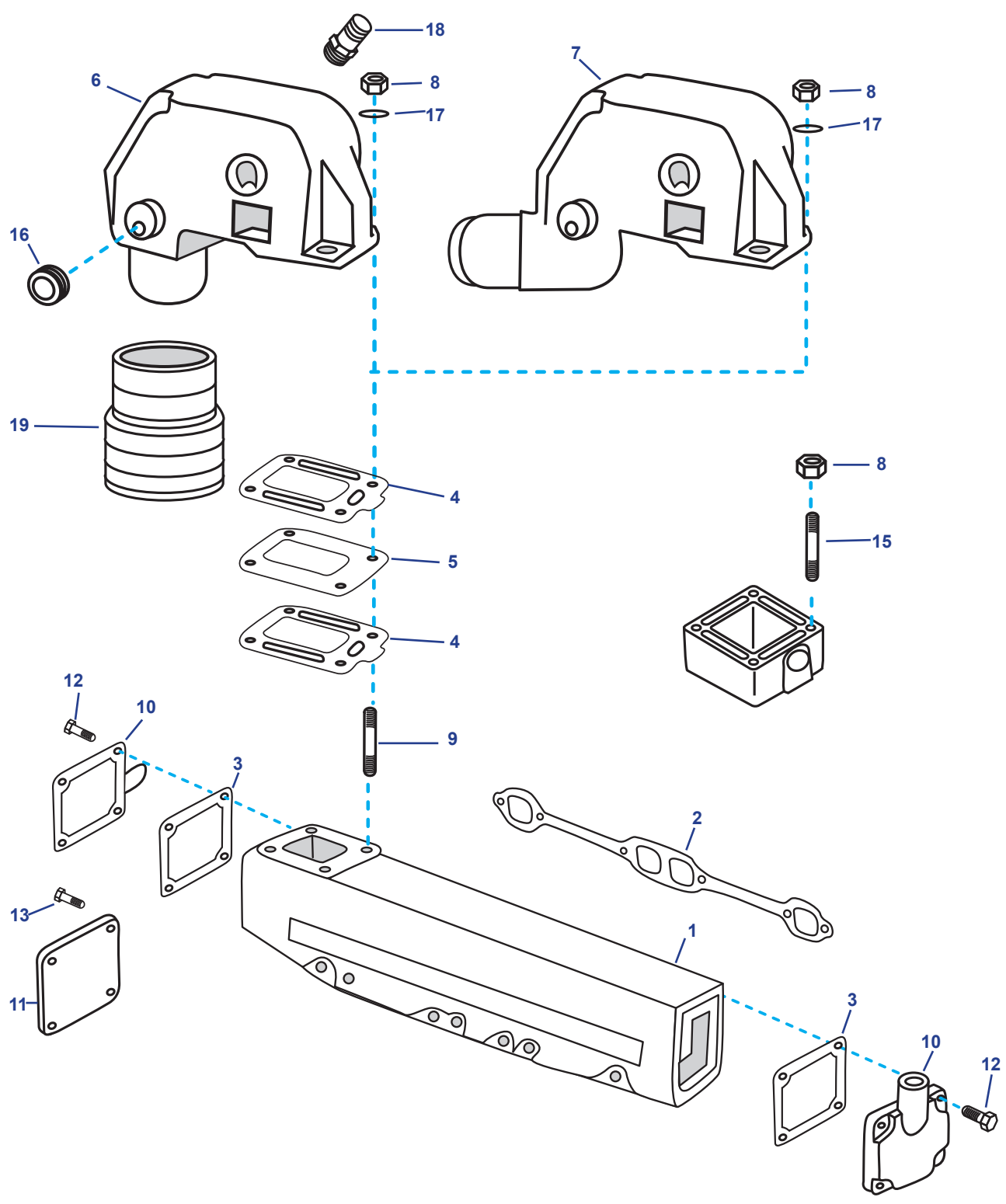

**NEW  
NEW**

**NEW  
NEW**

Nº	Ref.	R.O. OEM	Descripción	Description	Descrizione	Cantidad Qty Quantità
1	HOT20950	77234A7	COLECTOR BABOR	EXHAUST MANIFOLD PORT	COLLETTORE DI SINISTRA	1
1	HOT20951	77235A8	COLECTOR ESTRIBOR	EXHAUST MANIFOLD STARBOARD	COLLETTORE DI DESTRA	1
2	REC27-33395	27-33395	JUNTA COLECTOR	GASKET EXHAUST MANIFOLD	GUARNIZIONE COLLETTORE	1
2	FEL17420	27-33395	KIT JUNTAS COLECTOR	EXHAUST MANIFOLD KIT	KIT GUARNIZIONI COLLETTORE	1
3	REC27-480431	27-480431	JUNTA TAPA	GASKET END CAP	GUARNIZIONE COPERCHIO	2
4	REC27-99777Q02	27-99777Q02	JUNTA CODO	GASKET EXHAUST ELBOW	GUARNIZIONE COPERCHIO	2
5	REC60207	60207	TAPA COLECTOR	PLATE	PIASTRA	1
6	HOT20971	76351A04	CODO 90°	EXHAUST ELBOW ASSY. 3" 90°	GOMITO 90°	1
7	HOT20978	76771A2	CODO 0°	EXHAUST ELBOW ASSY. 3" 0°	GOMITO 0°	1
7	REC76771A2	76771A2	CODO 0°	EXHAUST ELBOW ASSY. 3" 0°	GOMITO 0°	1
8	REC46335	46335	TUERCA CODO	FLANGE SERRATED NUT	DADO	4
9	REC16-49545	16-49545	ESPÁRRAGO	STUD	PRIGIONIERO	4
10	REC60252A2	60252A2	TAPA COLECTOR	END CAP EXHAUST MANIFOLD	COPERCHIO COLLETTORE	2
11	HGE4870	73813A1	TAPA COLECTOR	END CAP EXHAUST MANIFOLD	COPERCHIO COLLETTORE	1
12	REC10-35386	10-35386	TORNILLO	SCREW END CAP	VITE	8
13	RM10-25299	10-824941	TORNILLO	SCREW END CAP	VITE	4
15	REC16-97520	16-97520	ESPÁRRAGO	STUD	PRIGIONIERO	4
16	REC22-41622	22-41622	TAPON CODO	ELBOW PLUG	TAPPO GOMITO	2
17	REC13-35048	13-35048	ARANDELA	WASHER	RONDELLA	4
18	REC22-866725	22-866725	RACORD COLECTOR	STRAIGHT FITTING	RACCORDO COLLETTORE	2
19	REC70981A3	70981A3	FUELLE ESCAPE	EXHAUST BELOW	MANICOTTO SCARICO	2

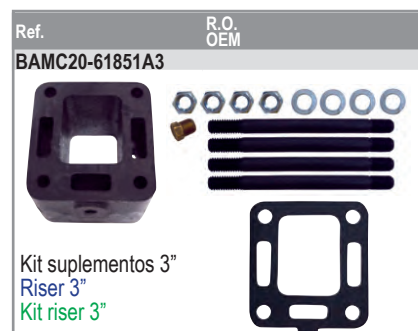
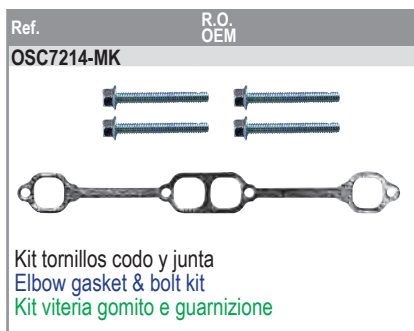

200, 228, 230, 230 MIE, 5.0L, 5.0LX, 898, 5.0L MPI,  
GM305 CID, 260, 260 MIE, 320 EFI, 350 MAG,  
GM350 CID, 5.7L, 5.7LX, 6.2L MPI V8 (1983 + 2003)

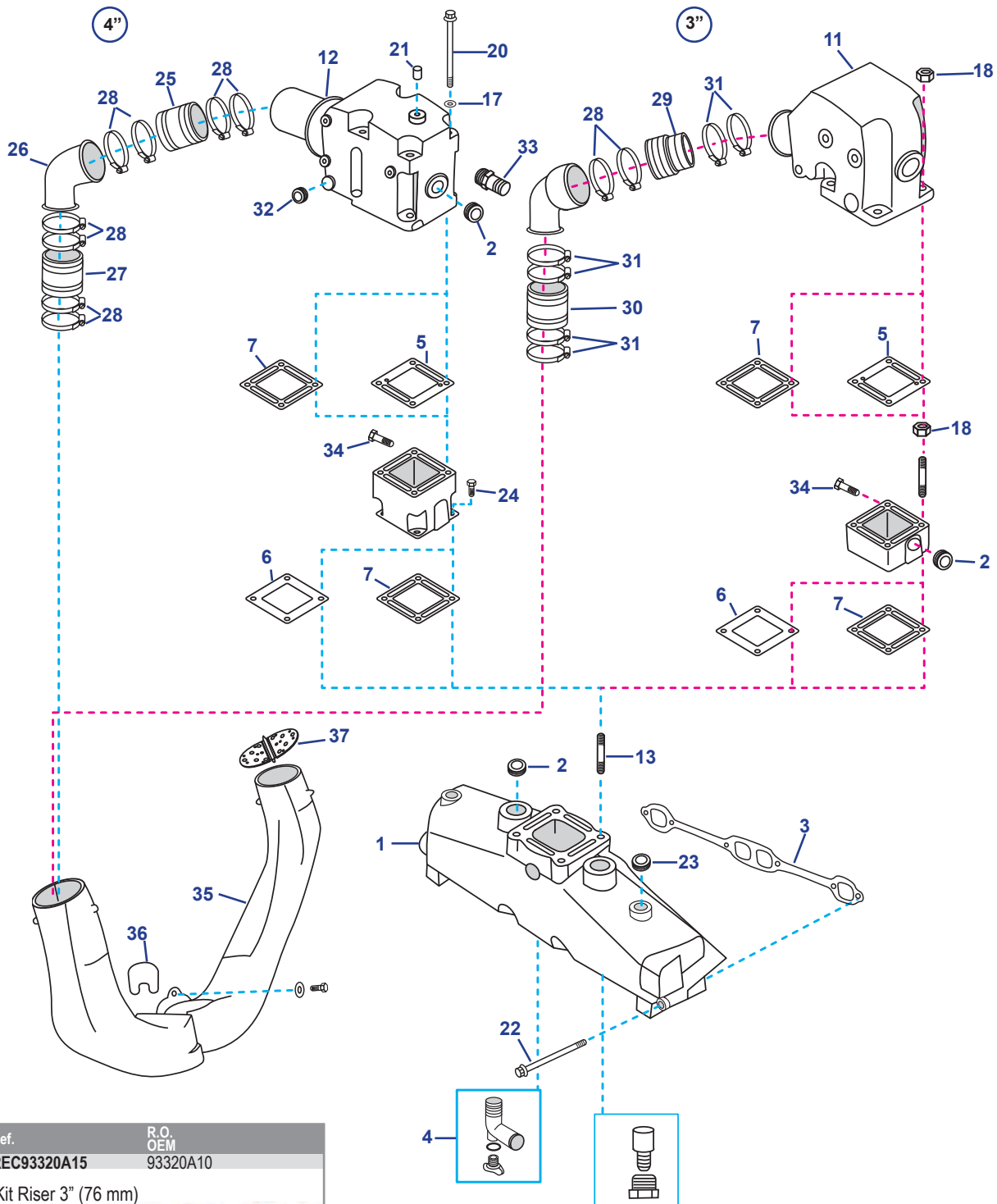

Ref.	R.O. OEM
REC93320A15	93320A10
Kit Riser 3" (76 mm)	
<p><b>Ajustado para / FITS / Si adatta:</b>                  2001-02 MCM 4.3L MPI (OM300000-OM614999),                  2001-02 MCM V8 (305, 350 &amp; 377 CID) MPI engine                  (OM300000-OM599999),                  2001-02 MIE &amp; Ski V8 (350 &amp; 377 CID) MPI engines                  (OM300000-OM316999).                  Sólo apto para motores con codos de hierro fundido.                  Fits only the above engines with cast iron elbows.                  Adatto solo per i motori con i gomiti di ghisa.</p>	

Ref.	R.O. OEM
RECK8503	
<p>Kit tornillos codo y junta                  Elbow gasket &amp; bolt kit                  Kit viteria gomito e guarnizione</p>	

Ref.	R.O. OEM
REC53400	
<p>Kit tornillos codo y junta                  Elbow gasket &amp; bolt kit                  Kit viteria gomito e guarnizione</p>	

Nº	Ref.	R.O. OEM	Descripción	Description	Descrizione	Cantidad Quantity Quantità
1	MAR246	860246A15	COLECTOR	MANIFOLD	COLLETTORE	2
1	HOT20953	860246A15	COLECTOR	MANIFOLD	COLLETTORE	2
2	REC22-41622	22-41622	TAPÓN ACERO	PLUG (STEEL)	TAPPO IN ACCIAIO	2
2	REC22-428611	22-428611	TAPÓN BRONCE	PLUG (BRASS)	TAPPO IN BRONZO	2
3	REC27-33395	27-33395	JUNTA COLECTOR	GASKET EXHAUST MANIFOLD	GUARNIZIONE COLLETTORE	2
3	FEL17420	27-33395	KIT JUNTAS	GASKET EXHAUST MANIFOLD	KIT GUARNIZIONI	2
4	REC862210A01	22-862210A01	KIT TAPÓN Y CONDUCTO	HOSE FITTING WITH DRAIN PLUG KIT	KIT TAPPO	1
5	REC27-863724Q	27-863724Q	JUNTA COLECTOR CIRCUITO CERRADO	GASKET MANIFOLD RAW WATER COOLING	GUARNIZIONE COLLETTORE CIRCUITO APERTO	1
6	REC27-8637251	27-8637251	JUNTA COLECTOR CIRCUITO AGUA DULCE	GASKET MANIFOLD FOR FRESH WATER COOLING	GUARNIZIONE COLLETTORE CIRCUITO CHIUSO	1
7	REC27-863726	27-863726	JUNTA GASKET	MANIFOLD AND SPACERS	GUARNIZIONE PER DISTANZIALE GASKET	1
11	HOT20970	98504A3	CODO HIERRO	ELBOW (IRON CASTING) 3" 15°	GOMITO IN GHISA	2
11	REC98504A3	98504A3	CODO HIERRO	ELBOW (IRON CASTING) 3" 15°	GOMITO IN GHISA	2
12	MAR988	807988A03	CODO HIERRO	ELBOW (IRON CASTING) 4" 7°	GOMITO IN GHISA	2
12	HOT20976	807988A03	CODO HIERRO	ELBOW (IRON CASTING)	GOMITO IN GHISA	2
12	SED3092600		CODO INOX	ELBOW INOX 4" 7°	GOMITO INOX	2
13	REC16-49545	16-49545	TORNILLO	STUD (STEEL)	VITE	1
17	REC13-35048	13-35048	CIERRE	LOCKWASHER	CHIUSURA	4
18	REC46335	46335	TUERCA CODO	FLANGE SERRATED NUT	DADO GOMITO	4
20	REC10-43749	10-43749	TORNILLO ACERO	SCREW STEEL ZINC PLATED	VITE IN ACCIAIO	4
21	REC22-73379	22-73379	TAPÓN	PLUG	TAPPO	1
22	REC10-53728	10-53728	TORNILLO	SCREW	VITE	4
23	REC22-384071	22-384071	TAPÓN	PLUG	TAPPO	1
24	REC10-865982005	10-865982005	TORNILLO	SCREW	VITE	1
25	REC32-44348001	32-44348001	FUELLE ESCAPE 4"	EXHAUST BELLOW 4"	CUFFIA SCARICO 4"	1
26	BAMC-20-14478	14478T01	TUBO	TUBE	TUBO	1
26	RM14801A1	14801A1	KIT SUPLEMENTOS	KIR RISER	KIT DISTANZIALE	1
27	REC32-14358001	32-14358001	FUELLE ESCAPE 4"	EXHAUST BELLOW 4"	CUFFIA SCARICO 4"	1
28	GS38322	54-815504372	ABRAZADERA	CLAMP	FASCETTA	1
29	REC70981A3	70981A3	FUELLE ESCAPE 3"	EXHAUST BELLOW 3"	CUFFIA SCARICO 3"	1
30	REC32-90949T	32-90949T	FUELLE ESCAPE 3"	EXHAUST BELLOW 3"	CUFFIA SCARICO 3"	1
31	GS38320	54-815504256	ABRAZADERA	CLAMP	FASCETTA	1
32	REC22-36382	22-36382	TAPÓN	PLUG	TAPPO	1
33	REC22-866725	22-866725	RACORD COLECTOR	STRAIGHT FITTING	RACCORDO COLLETTORE	2
34	REC22-328022	22-328022	TAPÓN	CAP	TAPPO	2
35	RM807130A4	807130A4	CUERNOS DE ESCAPE	EXHAUST PIPE	CORNA DI SCARICO	1
36	REC41802	41802	RETÉN TRANSON	TRANSON GASKET	GUARNIZIONE TRANSON	1
37	REC807166A1	807166A1	PALOMILLA ESCAPE	WATER SHUTTER	FARFALLA SCARICO	2

Ref. R.O. OEM  
HOT27214-MK

**NEW**

Kit montaje para HOT20950 y HOT20951  
Mounting kit elbow HOT20950 & HOT20951  
Kit di montaggio gomito HOT20950 e HOT20951

Ref. R.O. OEM  
OSC7214-MK

Kit tornillos codo y junta  
Elbow gasket & bolt kit  
Kit viteria gomito e guarnizione

Ref. R.O. OEM  
HOT20976-MK

**NEW**

Kit montaje para HOT20976  
Mounting kit elbow HOT20976  
Kit di montaggio gomito HOT20976

Ref. R.O. OEM  
HOT28503-MK

**NEW**

Kit montaje para HOT20970  
Mounting kit elbow HOT20970  
Kit di montaggio gomito HOT20970

Ref. R.O. OEM  
MAR3320PAR  
HOT20908

**NEW**

Kit Riser 3" (76 mm)  
3" Riser Kit (76 mm)  
Kit Distanziale 3" (76 mm)

Ref. R.O. OEM  
HOT20985

**NEW**

Kit Riser 6" (152 mm)  
6" Riser Kit (152 mm)  
Kit Distanziale 6" (152 mm)



330, 340MIE, 370TRS, 454EFI, 454MAG,  
7.4MIE, 7.4L, 7.4LX, GM454 CID V8 / 502 EFI,  
502 MAG, 8.2L, GM502 CID V8

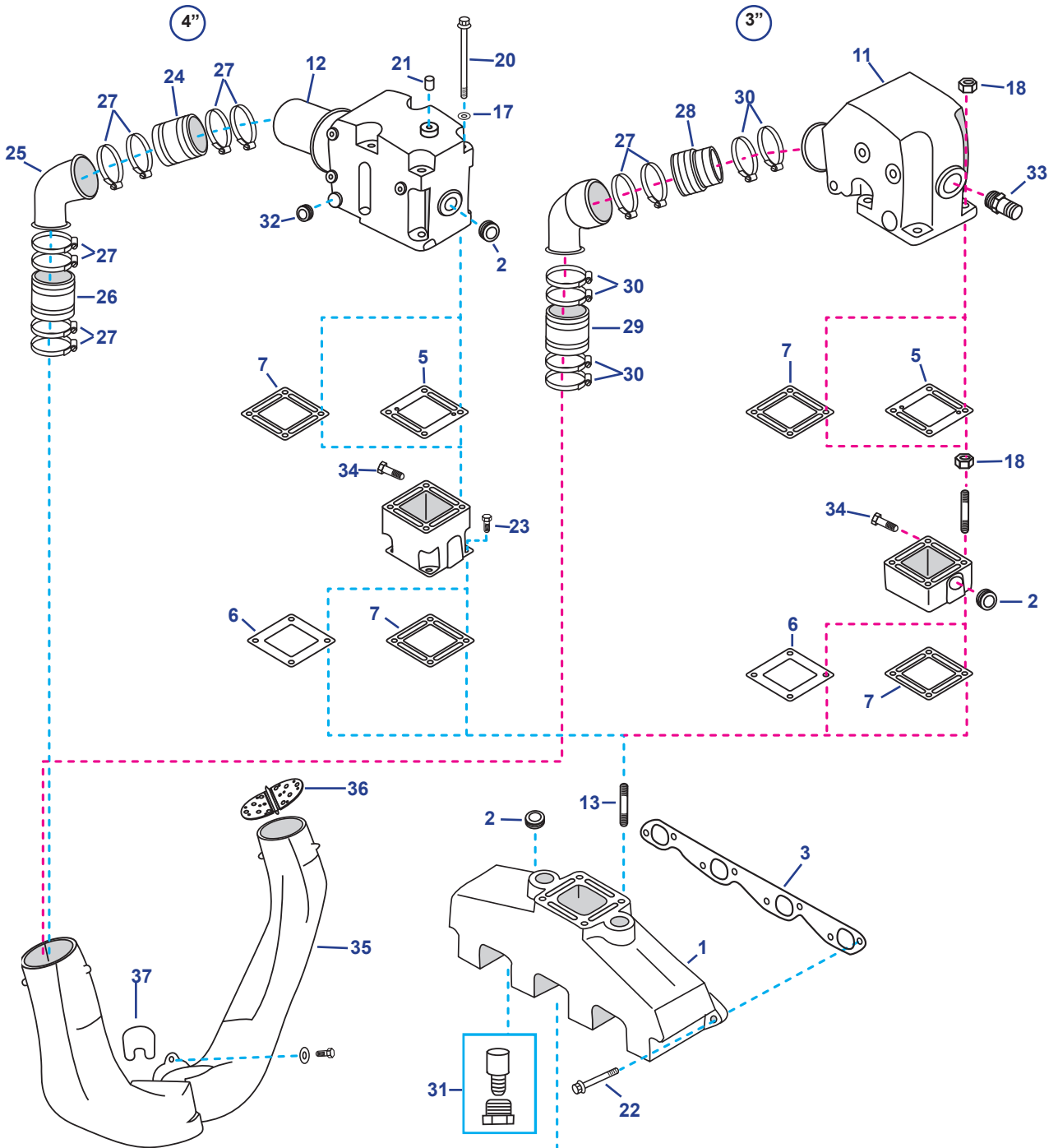

**NEW**

Ref.	R.O. OEM
MAR3320PAR	93320A13
HOT20908	93320A13

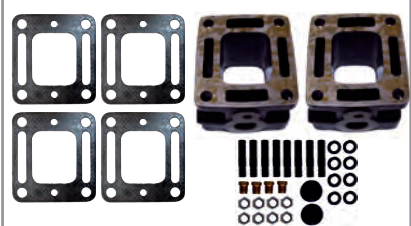

Kit Riser 3" (76 mm)  
3" Riser Kit (76 mm)  
Kit Distanziale 3" (76 mm)

Ref.	R.O. OEM
HOT20985	93322A12AV

**NEW**

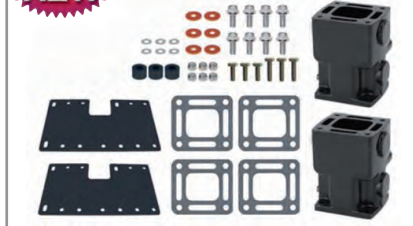

Kit Riser 6" (152 mm)  
6" Riser Kit (152 mm)  
Kit Distanziale 6" (152 mm)

Nº	Ref.	R.O. OEM	Descripción	Description	Descrizione	Cantidad Qty Quantità
1	MAR078	807078T10	COLECTOR HIERRO	EXHAUST MANIFOLD ASSEMBLY (IRON )	COLLETORE IN GHISA	2
<b>NEW</b>	HOT20957	807078T10	COLECTOR HIERRO	EXHAUST MANIFOLD ASSEMBLY (IRON )	COLLETORE IN GHISA	2
2	REC22-41622	22-41622	TAPÓN ACERO	PLUG (STEEL)	TAPPO ACCIAIO	2
2	REC22-428611		TAPÓN BRONCE	PLUG (BRASS)	TAPPO IN BRONZO	2
3	REC27-46820	27-46820	JUNTA COLECTOR	GASKET EXHAUST MANIFOLD	GUARNIZIONE COLLETORE	2
3	FEL17440	27-46820	KIT JUNTAS COLECTOR	GASKET EXHAUST MANIFOLD	KIT GUARNIZIONI COLLETORE	2
4	REC862210A01	22-862210A01	KIT TAPÓN Y CONDUCTO	HOSE FITTING WITH DRAIN PLUG KIT	KIT RUBINETTO	1
5	REC27-863724Q	27-863724Q	JUNTA COLECTOR CIRCUITO CERRADO	MANIFOLD-RAW WATER COOLING	GUARNIZIONE COLLETORE CIRCUITO APERTO	1
6	REC27-8637251	27-8637251	JUNTA COLECTOR CIRCUITO AGUA DULCE	MANIFOLD FRESH WATER COOLING	GUARNIZIONE COLLETORE CIRCUTO CHIUSO	1
7	REC27-863726	27-863726	JUNTA	GASKET EXHAUST MANIFOLD AND SPACERS	GUARNIZIONE	1
<b>NEW</b>	HOT20970	98504A3	CODO HIERRO 3" 15°	EXHAUST ELBOW (IRON CASTING) 3", 15°	GOMITO IN GHISA 3" 15°	1
	REC98504A3	98504A3	CODO HIERRO 3" 15°	EXHAUST ELBOW (IRON CASTING) 3", 15°	GOMITO IN GHISA 3" 15°	1
	MAR988	807988A03	CODO HIERRO 4" 7°	EXHAUST ELBOW (IRON CASTING) 4", 7°	GOMITO IN GHISA 4" 7°	1
<b>NEW</b>	HOT20976	807988A03	CODO HIERRO 4" 7°	EXHAUST ELBOW (IRON CASTING) 4", 7°	GOMITO IN GHISA 4" 7°	1
	SED3092600	807988A03	CODO INOX 4" 7°	EXHAUST ELBOW INOX, 4", 7°	GOMITO INOX 4" 7°	1
	REC16-49545	16-49545	ESPÁRRAGO 3/8" x 1 <sup>3/4</sup> "	STUD 3/8" x 1 <sup>3/4</sup> "	PRIGIONIERO 3/8" x 1 <sup>3/4</sup> "	4
	REC13-35048	13-35048	CIERRE	LOCKWASHER	CHIUSURA	4
	REC46335	46335	TUERCA	FLANGE SERRATED NUT	DADO	4
	REC10-43749	10-43749	TORNILLO	SCREW STEEL ZINC PLATED	VITE	4
	REC22-73379	22-73379	TAPÓN	PLUG	TAPPO	1
	REC10-37612	10-37612	TORNILLO	SCREW	VITE	8
	REC10-865982005	10-865982005	TORNILLO	SCREW	VITE	4
	REC32-44348001	32-44348001	FUELLE ESCAPE 4"	EXHAUST BELLOW 4"	CUFFIA SCARICO 4"	1
	BAMC-20-14478	14478T01	TUBO	TUBE	TUBO	1
	REC32-14358001	32-14358001	FUELLE ESCAPE 4"	EXHAUST BELLOW 4"	CUFFIA SCARICO 4"	1
	GS38322	54-815504372	ABRAZADERA	CLAMP	FASCETTA	10
	REC70981A3	70981A3	FUELLE ESCAPE 3"	EXHAUST BELLOW 3"	CUFFIA SCARICO 3"	1
	REC32-90949T	32-90949T	FUELLE ESCAPE 3"	EXHAUST BELLOW 3"	CUFFIA SCARICO 3"	1
	GS38320	54-815504256	ABRAZADERA	CLAMP	FASCETTA	6
	REC22-36382	22-36382	TAPÓN	PLUG	TAPPO	2
	REC22-866725	22-866725	RACORD COLECTOR	STRAIGHT FITTING	RACCORDO COLLETORE	2
	REC22-328022	22-328022	TAPÓN	PLUG	TAPPO	2
	RM807130A4	807130A4	CUERNOS DE ESCAPE	EXHAUST PIPE	CORNA DI SCARICO	1
	REC807166A1	807166A1	PALOMILLA DE ESCAPE	WATER SHUTTER	FARFALLA SCARICO	2
	REC41802	41802	RETÉN TRANSON	TRANSON GASKET	GUARNIZIONE TRANSON	1

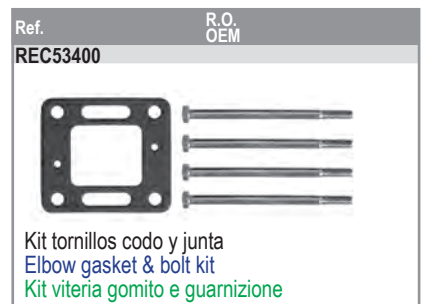

**325-325MIE, GM427 CID V8 / 330-330MIE  
370TRS - 400TRS - 440TRS - GM454 CID / 390 - 390MIE  
- 460TRS, GM472 CID V8 - 225 - 225MIE - 250 - 250MIE  
- GM327CID - 228 - 228MIE - GM305CID - 250 - 270 -  
270MIE - 280TRS - GM350 CID V8**

114

MERCURISER

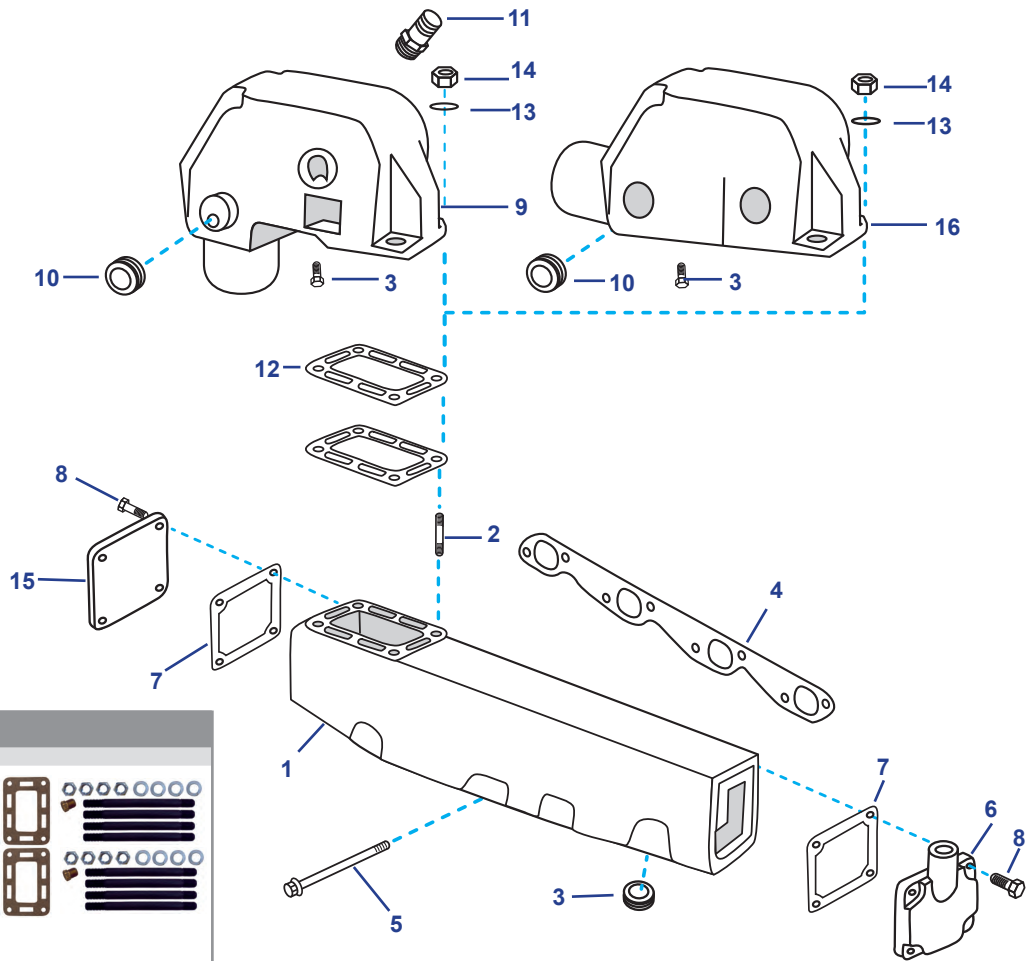

Ref.	R.O. OEM
<b>BAMC20-61811A4</b>	
Kit tornillos codo y junta Elbow gasket & bolt kit Kit viteria gomito e guarnizione	

Nº	Ref.	R.O. OEM	Descripción	Description	Descrizione
1	BAMC1-47735	47735A17	COLECTOR BABOR	PORT MANIFOLD	COLLETTORE DI SINISTRA
1	BAMC1-47736	47736A17	COLECTOR ESTRIBOR	STBD MANIFOLD	COLLETTORE DI DESTRA
1	BAMC1-47737	47737A1	COLECTOR BABOR (225 - 228 - 250 - 270 - 280 - 305 - 327 - 350)	PORT MANIFOLD (225 - 228 - 250 - 270 - 280 - 305 - 327 - 350)	COLLETTORE DI SINISTRA (225 - 228 - 250 - 270 - 280 - 305 - 327 - 350)
1	BAMC1-47738	47738A1	COLECTOR ESTRIBORD (225 - 228 - 250 - 270 - 280 - 305 - 327 - 350)	STBD MANIFOLD (225 - 228 - 250 - 270 - 280 - 305 - 327 - 350)	COLLETTORE DI DESTRA (225 - 228 - 250 - 270 - 280 - 305 - 327 - 350)
2	REC16-49545	16-49545	TORNILLO CODO COLECTOR	STUD MANIFOLD	VITE GOMITO COLLETTORE
3	REC22-328022	22-328022	TAPÓN	CAP	TAPPO
4	REC27-46820	27-46820	KIT JUNTAS COLECTOR	GASKET EXHAUST MANIFOLD	KIT GUARNIZIONI COLLETTORE
4	REC27-33395	27-33395	KIT JUNTAS COLECTOR (225 - 228 - 250 - 270 - 280 - 305 - 327 - 350)	GASKET EXHAUST MANIFOLD (225 - 228 - 250 - 270 - 280 - 305 - 327 - 350)	KIT GUARNIZIONI COLLETTORE (225 - 228 - 250 - 270 - 280 - 305 - 327 - 350)
5	REC10-37612	10-37612	TORNILLO 1 <sup>1/4"</sup>	SCREW 1 <sup>1/4"</sup>	VITE 1 <sup>1/4"</sup>
7	REC27-480431	27-480431	JUNTA	GASKET	GUARNIZIONE
8	REC10-35386	10-35386	TORNILLO TAPA COLECTOR	SCREW MANIFOLD COVER	VITE COPERCHIO COLLETTORE
9	BAMC20-76668	76668A3	CODO ESCAPE	EXHAUST ELBOW	GOMITO SCARICO
10	REC22-41622	22-41622	TAPÓN CODO	ELBOW PLUG	GOMITO SCARICO
11	REC22-866725	22-866725	RACORD COLECTOR	STRAIGHT FITTING	TAPPO GOMITO
12	REC27-48042	27-48042	JUNTA	GASKET	RACCORDO COLLETTORE
13	REC13-35048	13-35048	ARANDELA	WASHER	GUARNAIZIONE
14	REC46335	11-46335	TUERCA CODO	NUT	RONDELLA
15	HGE4870	73813A1	TAPA COLECTOR	MANIFOLD COVER	DADO GOMITO
16	BAMC20-72963	72963A9	CODO ESCAPE	EXHAUST ELBOW	COPERCHIO COLLETTORE

# 215, 225, 225MIE, 888 FORD 302 V8 233, 233MIE, 255, 255MIE, FORD 351 V8

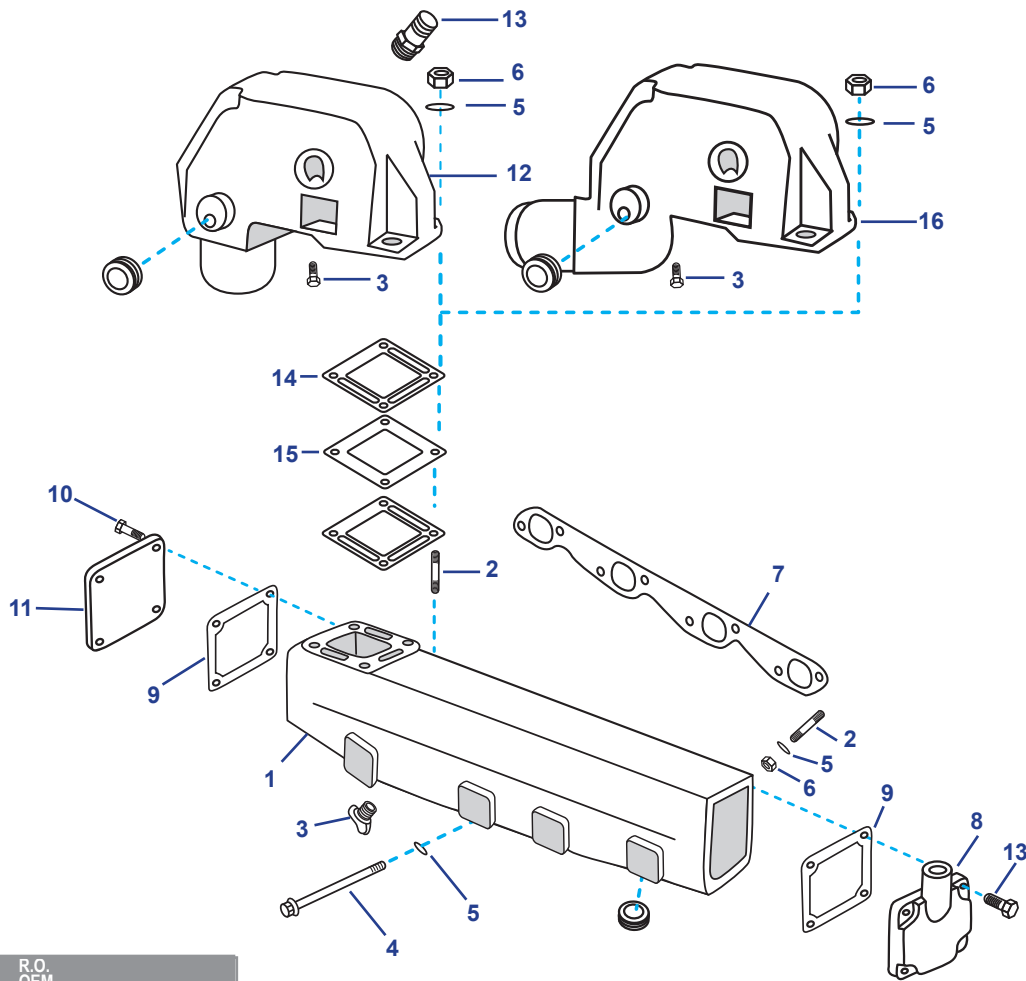

Nº	Ref.	R.O. OEM	Descripción	Description	Descrizione
<b>NEW</b>	1	HOT20962	COLECTOR ESTRIBOR	STBD MANIFOLD	COLLETTORE DI DESTRA
<b>NEW</b>	1	HOT20958	COLECTOR BAVOR	PORT MANIFOLD	COLLETTORE DI SINISTRA
	2	REC16-49545	TORNILLO CODO COLECTOR	STUD MANIFOLD	VITE GOMITO COLLETTORE
	3	REC22-328022	TAPÓN	CAP	TAPPO
	4	REC10-37612	TORNILLO 1 <sup>1/4</sup> "	SCREW 1 <sup>1/4</sup> "	VITE 1 <sup>1/4</sup> "
	5	REC13-35048	ARANDELA	WASHER	RONDELLA
	6	REC46335	TUERCA CODO	NUT	DADO GOMITO
	7	REC3852455	JUNTA COLECTOR ESCAPE	MANIFOLD GASKET	GUARNIZIONE COLLETTORE SCARICO
	8	REC60252A2	TAPA COLECTOR	END CAP ASSY	COPERCHIO COLLETTORE
	9	REC27-480431	JUNTA	GASKET	GUARNIZIONE
	10	REC10-35386	TORNILLO TAPA COLECTOR	SCREW MANIFOLD COVER	VITE COPERCHIO COLLETTORE
	11	HGE4870	TAPA COLECTOR	MANIFOLD COVER	COPERCHIO COLLETTORE
<b>NEW</b>	12	HOT20971	CODO ESCAPE	EXHAUST ELBOW	GOMITO DI SCARICO
	12	HGE6351	CODO ESCAPE	EXHAUST ELBOW	GOMITO DI SCARICO
	13	REC22-866725	RACORD COLECTOR	STRAIGHT FITTING	RACCORDO COLLETTORE
	14	REC27-99777Q02	JUNTA	GASKET	GUARNIZIONE
	15	REC60207	TAPA COLECTOR	MANIFOLD COVER	COPERCHIO COLLETTORE
<b>NEW</b>	16	HOT20978	CODO ESCAPE	EXHAUST ELBOW	GOMITO DI SCARICO

# COLECTORES MANIFOLDS COLLETTORE

Ref.	R.O. OEM
BAMC-1-63122	63122A10 63122A13 63122A14

DESPIECE  
PARTS  
ESPLOSO  
P. 93

**MOTORES / ENGINES / MOTORI**  
120HP GM153



Ref.	R.O. OEM
REC96705A1	96705A1

DESPIECE  
PARTS  
ESPLOSO  
P. 94

**MOTORES / ENGINES / MOTORI**

Se adapta a la mayoría de los modelos 3.0L 181 CID con carburador Rochester 2.5L, 153 CID (1968-82)  
Fits most models 3.0L 181 CID with Rochester carburator, 2.5L 153 CID (1968-82)  
Si adatta alla maggior parte dei modelli 3.0L 181 CID con carburatore Rochester 2.5L, 153 CID (1968-82)



Ref.	R.O. OEM
BAMC-1-95862	95862A5

DESPIECE  
PARTS  
ESPLOSO  
P. 96

**MOTORES / ENGINES / MOTORI**

Se adapta a la mayoría de los modelos 2.5L 153 CID y 3.0L 181 CID con carburador Rochester (1983-89)  
Fits most models 2.5L 153 CID & 3.0L 181 CID with Rochester carburator, (1983-89)  
Si adatta alla maggior parte dei modelli 2.5L 153 CID e 3.0L 181 CID con carburatore Rochester (1983-89)



Ref.	R.O. OEM
HOT20956	99798A18 806867A8 806235A04

DESPIECE  
PARTS  
ESPLOSO  
P. 96

**MOTORES / ENGINES / MOTORI**

Se adapta a la mayoría de los modelos 2.5L 153 CID y 3.0L 181 CID con carburador Mercab y Electric Chore (1983-95)  
Fits most models 2.5L 153 CID & 3.0L 181 CID with carburator Mercab & Electric Chore, (1983-95)  
Si adatta alla maggior parte dei modelli 2.5L 153 CID e 3.0L 181 CID con carburatore Mercab e Electric Chore (1983-95)

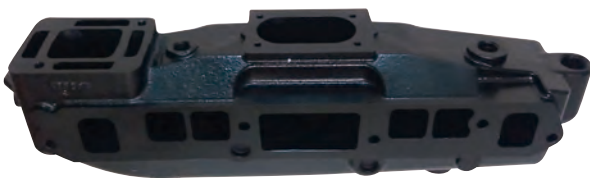

Ref.	R.O. OEM
RM816219A4	816219A4

DESPIECE  
PARTS  
ESPLOSO  
P. 99

R.O. OEM	Descripción	Description	Descrizione	Cantidad Qty Quantità
98562A6	Suplemento de hierro	Cast iron riser	Supplemento in ghisa	1
816219A5	Colector escape de aluminio	Aluminium exhaust manifold	Collettore scarico in alluminio	1
	Kit de montaje, juntas, entroques...	Mounting kit, gaskets, nipples...	Kit montaggio, guarnizione, raccordi	1

**MOTORES / ENGINES / MOTORI**

3.7L & 3.7LX  
470, 485, 488 (1980-85)  
160, 170, 180, 190 3.7L & 3.7LX (1985-89)



Ref.	R.O. OEM
HGE6219-A	816219A5

DESPIECE  
PARTS  
ESPLOSO  
P. 99

**MOTORES / ENGINES / MOTORI**

3.7L & 3.7LX 170/470 (1980-89)  
Colector de escape de aluminio.  
Exhaust manifold in aluminium.  
Collettore di scarico in alluminio.



Ref.	R.O. OEM
BAMC-1-58759	58759A1 58759A10 58759A13 58759A14

DESPIECE  
PARTS  
ESPLOSO  
P. 100

**MOTORES / ENGINES / MOTORI**

GM160 & GM165 (6 CYL)



Ref.	R.O. OEM
MAR746	99746A8
HOT20952	99746A17
	99746A3

**NEW**

**MOTORES / ENGINES / MOTORI**  
GM 4.3L & 3.8L V6  
175, 185, 205, 229 & 262  
(1985-02)



DESPIECE PARTS ESPLOSO  
**P. 102**

Ref.	R.O. OEM
MAR078	807078T10
	807078T09
HOT20957	807078A6
	89011A8

**NEW**

**MOTORES / ENGINES / MOTORI**  
GM V8 BIG BLOCK  
330, 340, 370 (454) 7.4L  
502 8.2L



DESPIECE PARTS ESPLOSO  
**P. 112**

Ref.	R.O. OEM
MAR612	864612T01

**MOTORES / ENGINES / MOTORI**  
GM 4.3L MPI OM615000+  
(2002+) 262



DESPIECE PARTS ESPLOSO  
**P. 104**

COLECTOR BAVOR PORT MANIFOLD COLLETTORE DI SINISTRA		COLECTOR ESTRIBOR STD MANIFOLD COLLETTORE DI DESTRA	
Ref.	R.O. OEM	Ref.	R.O. OEM
HOT20950	77234A7	HOT20951	77235A8
	77234A2		77235A2

**MOTORES / ENGINES / MOTORI**  
198, 228, 250, 255, 260, 898, 305CID  
(GM V8)

Bloque pequeño con suplemento  
Small blocks with end riser  
Blocco piccolo con supplemento

**NEW**



DESPIECE PARTS ESPLOSO  
**P. 108**

Ref.	R.O. OEM
MAR735	865735A02
HOT20735	864308T01
	865049T01

**NEW**

**MOTORES / ENGINES / MOTORI**  
50L, 5.7L, 6.2L (V8)  
305, 350, 377  
(2002+)



DESPIECE PARTS ESPLOSO  
**P. 106**

COLECTOR BAVOR PORT MANIFOLD COLLETTORE DI SINISTRA		COLECTOR ESTRIBOR STD MANIFOLD COLLETTORE DI DESTRA	
Ref.	R.O. OEM	Ref.	R.O. OEM
BAMC1-47735	47735A17	BAMC1-47736	47736A17
	47735		47736
	47735A1		

**MOTORES / ENGINES / MOTORI**  
MCM/MIE GM V8 (427, 454 & 482 CID)  
(-1981)



DESPIECE PARTS ESPLOSO  
**P. 114**

Ref.	R.O. OEM
MAR246	860246A15
	87114A19
	860246A3
HOT20953	860246A9
	860246A10

**NEW**

**MOTORES / ENGINES / MOTORI**  
305, 350 & 377 V8GM  
(1983-02)



DESPIECE PARTS ESPLOSO  
**P. 110**

COLECTOR BAVOR PORT MANIFOLD COLLETTORE DI SINISTRA		COLECTOR ESTRIBOR STD MANIFOLD COLLETTORE DI DESTRA	
Ref.	R.O. OEM	Ref.	R.O. OEM
BAMC1-47737	47737A10	BAMC1-47738	47738A10
	47737A1		47738A1

**MOTORES / ENGINES / MOTORI**  
GM SMALL BLOCK V8 (327, 305, 350)  
225, 250, 255, 270 & 280  
(1977+)



DESPIECE PARTS ESPLOSO  
**P. 114**

COLECTOR BAVOR PORT MANIFOLD COLLETTORE DI SINISTRA	
Ref.	R.O. OEM
HOT20958	65604A4 65604A12

**MOTORES / ENGINES / MOTORI**  
FORD V8 SMALL BLOCK (302, 351)  
215, 225, 225S, 233, 255 & 288  
(-1977)

COLECTOR ESTRIBOR STD MANIFOLD COLLETTORE DI DESTRA	
Ref.	R.O. OEM
HOT20962	65603A3 65603A12

**DESPIECE  
PARTS  
ESPLOSO**  
**P. 115**



Ref.	R.O. OEM
BAMC-1-860235	860235A03
HOT20966	806867A3 806867A12

**MOTORES / ENGINES / MOTORI**  
GM 181 (1990+)  
3.0L OM680000+  
3.0LX & 3.0TKS PLUS

**DESPIECE  
PARTS  
ESPLOSO**  
**P. 98**



## CODOS ELBOWS GOMITI

### CODO BAJO LOW ELBOW GOMITO BASSO

Ref.	R.O. OEM
MAR309	864309T02 864309T01

**MOTORES / ENGINES / MOTORI**  
GM V6 & V8  
262, 305, 350, 377, 383  
MPI (2002+)  
7° (4" O.D. RISER)

**DESPIECE  
PARTS  
ESPLOSO**  
**P. 104, 106**



Ref.	R.O. OEM
MAR988	807988A03 807988A2
HOT20976	807914A1 44354A3

**MOTORES / ENGINES / MOTORI**  
GM V6 & V8  
SMALL & BIG BLOCK  
(1983-02)  
7° (4" O.D. RISER)

**DESPIECE  
PARTS  
ESPLOSO**  
**P. 102, 110, 112**



### CODO ALTO HIGH ELBOW GOMITO ALTO

Ref.	R.O. OEM
MAR591	864591T02
HOT20591	

**MOTORES / ENGINES / MOTORI**  
GM V6 & V8  
262, 305, 350, 377, 385, 6.2L  
MPI (2002+)  
7° (4" O.D. RISER)

**DESPIECE  
PARTS  
ESPLOSO**  
**P. 104, 106**



Ref.	R.O. OEM
REC98504A3	98504A3
HOT20970	

**MOTORES / ENGINES / MOTORI**  
GM V6 & V8  
SMALL & BIG BLOCK  
(1983+)  
15° (3" O.D. RISER)

**DESPIECE  
PARTS  
ESPLOSO**  
**P. 102, 110, 112**

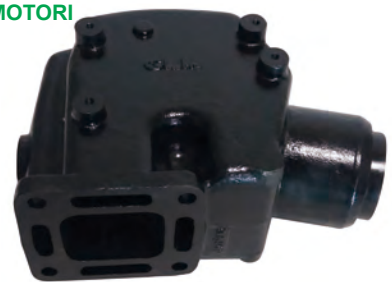

Ref.	R.O. OEM
BAMC20-72963	72963A9 72963A1 76788A1 48101A1

**MOTORES / ENGINES / MOTORI**  
GM V8 (454, 427, 482, 327, 350)  
225, 250, 270, 325, 390, 330, 350,  
370, 400, 440, 460 (1967-86)  
3" O.D. RISER

**DESPIECE  
PARTS  
ESPLOSO**  
**P. 114**



Ref.	R.O. OEM
HOT20975	12076A2

**MOTORES / ENGINES / MOTORI**  
GM 2.5L, 3.0 & 3.0LX  
(1982+)  
NEW MODEL

**DESPIECE  
PARTS  
ESPLOSO**  
**P. 96, 98**



Ref.	R.O. OEM
MAR076	12076A2



**MOTORES / ENGINES / MOTORI**

GM 2.5L, 3.0 & 3.0LX  
(1982+)  
NEW MODEL



Ref.	R.O. OEM
HOT20971	76351A04 76351A2 60426A1



**MOTORES / ENGINES / MOTORI**

MCM: 140, 470, 165 & 200 (6 CYL INLINE)  
GM V8 305,350  
FORD V8 302, 351  
(-1982)



Ref.	R.O. OEM
REC76771A2	76771A2 76771A3



**MOTORES / ENGINES / MOTORI**

V8 GM & FORD  
470 (224/L4)  
GM (6 CYL INLINE)  
(-1983)



Ref.	R.O. OEM
BAMC-20-55538	55538A2 39920



**MOTORES / ENGINES / MOTORI**

120 GM 153 (4 CYL) (1964-82)  
160 GM 250 (6 CYL INLINE) (1967-69)

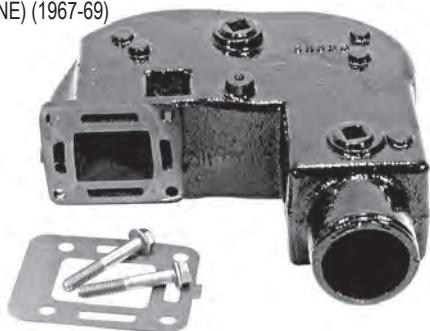

Ref.	R.O. OEM
REC76325A2	76325A2



**MOTORES / ENGINES / MOTORI**

GM 2.5L & 3.0L (1982-89)  
OLD MODEL (6 CYL INLINE)



Ref.	R.O. OEM
BAMC20-76668	76668A3 76668A1 72964A1 47877A4



**MOTORES / ENGINES / MOTORI**

GM (454, 350, 305, 330 V8)  
228, 250, 280, 288

Aplicación / Aplicacion / Applicazione:  
3" O.D. RISER



**CODO DE ESCAPE PARA COLECTOR. ALUMINIO  
EXHAUST ELBOW FOR MANIFOLD. ALUMINIUM  
GOMITO DI SCARICO PER COLLETTORE. ALLUMINIO**

Ref.	R.O. OEM
HOT20937	98562A6



**MOTORES / ENGINES / MOTORI**

165, 140, 180, 190  
3.7L & 3.7 LX  
(1985-89)



**CODO DE ESCAPE PARA COLECTOR. HIERRO  
EXHAUST ELBOW FOR MANIFOLD. IRON  
GOMITO DI SCARICO PER COLLETTORE. GHISA**

Ref.	R.O. OEM
HOT20905	90880A2



**MOTORES / ENGINES / MOTORI**

165, 170, 180, 190  
3.7L & 3.7 LX  
MCM (1980-89)





**CODOS INOX 316  
ELBOW 316 SS  
GOMITI INOS 316**



Ref.	R.O. OEM
SED3093300	805602A2

**MOTORES / ENGINES / MOTORI**  
530DTA, 636, D183, D2.8L, D219, D254,  
D3.0L, D3.6L, D4.2L



Ref.	R.O. OEM
SED3093301	80176320

**MOTORES / ENGINES / MOTORI**  
D183T / D219T / D530TA



Ref.	R.O. OEM
SED3092000	805602A1

**MOTORES / ENGINES / MOTORI**  
2.8L, D254, D3.6L, D4.2L



Ref.	R.O. OEM
SED3092900	805265A1

**MOTORES / ENGINES / MOTORI**  
QSD 2.8, 4.2 / DSD 2.8, 4.2



**CODOS INOX 316  
ELBOW 316 SS  
GOMITI INOS 316**



Ref.	R.O. OEM
SED3092610	12076A2

**MOTORES / ENGINES / MOTORI**  
4 CYL LATE MODELS



Ref.	R.O. OEM
SED3092600	807988A03

**MOTORES / ENGINES / MOTORI**  
V6 & V-8  
7° (4" O.D. RISER)



**CODO BAJO  
LOW ELBOW  
GOMITO BASSO**

Ref.	R.O. OEM
SED3095400	864309T02

**MOTORES / ENGINES / MOTORI**  
GM V6 & V8  
262, 305, 350, 377, 383  
MPI (2002+)  
4" O.D. RISER



**CODO ALTO  
HIGH ELBOW  
GOMITO ALTO**

Ref.	R.O. OEM
SED3095500	864591T02

**MOTORES / ENGINES / MOTORI**  
GM V6 & V8  
262, 305, 350, 377, 385, 6.2L  
MPI (2002+)  
4" O.D. RISER



# KITS DE SUPLEMENTOS RISERS MOUNTING KITS KIT DISTANZIALI

## KIT RISER 3" / 76 MM

**NEW**  
**NEW**

Ref.	R.O. OEM	PARA COLECTORES FOR MANIFOLDS PER COLLETTORI
MAR3320PAR	93320A13 807476A6	MAR746 MAR246
HOT20908	93320A5	MAR078 (-2002)

### MOTORES / ENGINES / MOTORI

305, 350, 262, 454, 502 (5.0, 5.7, 4.3, 7.4, 8.2)

### AJUSTADOS PARA / FITS / SI ADATTA

MCM V6 & TBI (2 colectores escape / 2 exhaust manifold / 2 collettore di scarico) (-0M614999)

MCM/MIE/SKI V8 (305, 350, 377, 354 & 502 CID) (Codo de hierro / cast iron elbow / gomito in ghisa) (-0M299999)

MCM V8 (305 & 350 CID) Carburador / carburetor / carburatore (0M300000-0M599999)

MIE & SKI Carburador / carburetor / carburatore (0M300000-0M316999)



Ref.	R.O. OEM	PARA COLECTORES FOR MANIFOLDS PER COLLETTORI
REC93320A15	93320A15 93320A10	MAR746 MAR246 MAR078 (-2002)

### AJUSTADOS PARA / FITS / SI ADATTA

MCM 4.3L MPI (0M3000000-0M614999) (2001-02)

MCM V8 (305, 350, 377 CID) MPI (0M300000-0M599999) (2001-02)

MIE & SKI V8 (350 & 377 CID) MPI (0M300000-0M316999) (2001-02)

Sólo codos de hierro / Only with cast iron elbows / Solo gomiti in ghisa

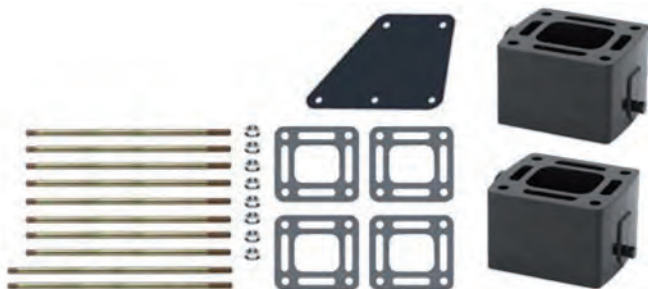

Ref.	R.O. OEM	PARA COLECTORES FOR MANIFOLDS PER COLLETTORI
HGE4929	864929A3	MAR612 HOT20735

### MOTORES / ENGINES / MOTORI

350, 357, 377, 383, 385 (MAG, MPI)

GM V6&V8 (4.3, 5.0, 5.7, 6.2) (2002+)



Ref.	R.O. OEM	PARA COLECTORES FOR MANIFOLDS PER COLLETTORI
BAMC20-61811A4	61811A4 61811A3	BAMC1-47736 BAMC1-47737 BAMC1-47738 BAMC1-47735

BASE RECTANGULAR / RECTANGULAR BASE / BASE RETTANGOLARE

### MOTORES / ENGINES / MOTORI

GM V8 (427, 454 & 582 CID)

327, 305, 350

225, 250, 255, 270 & 280

(1977+)

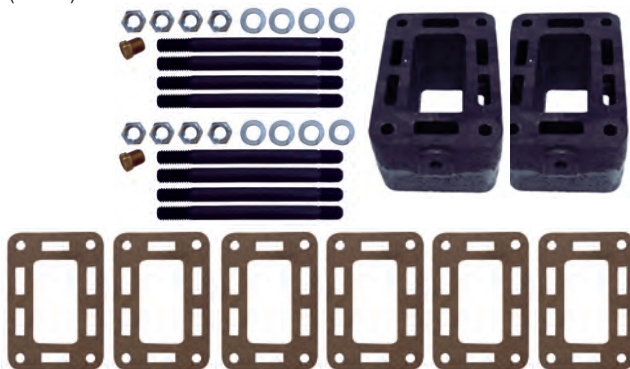

Ref.	R.O. OEM	PARA COLECTORES FOR MANIFOLDS PER COLLETTORI
BAMC20-61851A3	61851A3	REC96705A1 HOT20956 BAMC-1-58759

### MOTORES / ENGINES / MOTORI

140 HP (181 4cyl), 120 (2.5L), 153

GM 160, 165 (6 cyl inline)

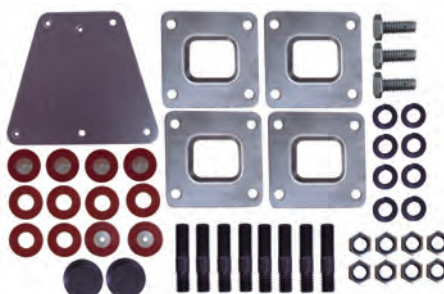
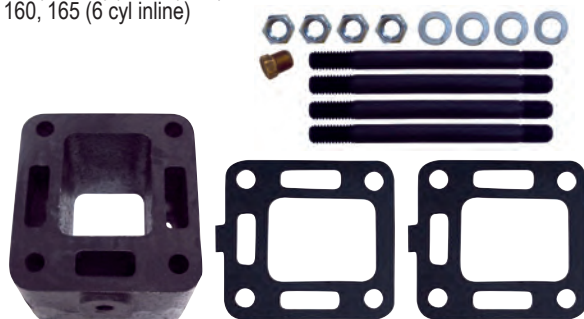

**KIT RISER 6" / 152 MM**

Ref.	R.O. OEM	PARA COLECTORES FOR MANIFOLDS PER COLLETTORI
HOT20985	93322A12	MAR746 MAR246 MAR078 (-2002)

**AJUSTADOS PARA / FITS / SI ADATTA**

MCM V6 & TBI (2 colectores escape / 2 exhaust manifold / 2 collettore di scarico) (-0M614999)  
MCM/MIE/SKI V8 (305, 350, 377, 354 & 502 CID) (Codo de hierro / cast iron elbow / gomito in ghisa) (-0M299999)  
MCM V8 (305 & 350 CID) Carburador / carburetor / carburatore (0M300000-0M599999)  
MIE & SKI Carburador / carburetor / carburatore (0M300000-0M316999)

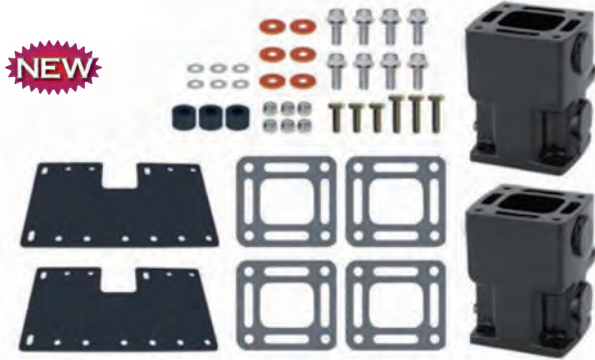

Ref.	R.O. OEM	PARA COLECTORES FOR MANIFOLDS PER COLLETTORI
BAMC-20-864908A1	864908A1	MAR612 HOT20735

**MOTORES / ENGINES / MOTORI**

350, 357, 377, 383, 385 (MAG, MPI)  
GM V6&V8 (4.3, 5.0, 5.7, 6.2) (2002+)

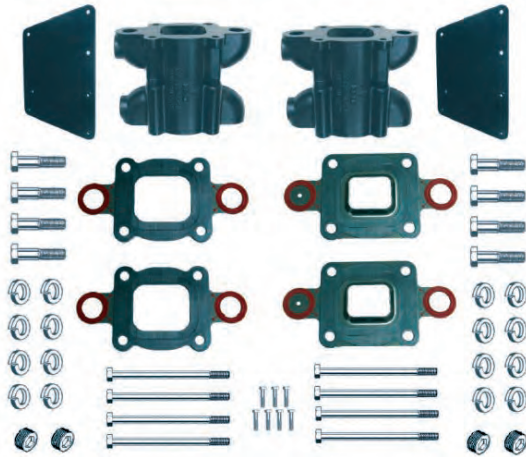

**EXTENSORES DE ESCAPE  
EXHAUST EXTENSIONS  
ESTENSIONI DI SCARICO**

Ref.	R.O. OEM	Ø
BAMC-20-14478	14478T01 14478T	4"

**MOTORES / ENGINES / MOTORI**

175, 205, 229, 262 (V6) (1983-05)  
200, 320, 305, 350, 377 (V8) (1993+)  
330, 370, 454, 502 (V8 BIG BLOCK) (1981+)



Ref.	R.O. OEM
RM14801A1	14801A1

**MOTORES / ENGINES / MOTORI**

5.0, 5.7, 6.2L V8 (1998+)

INSTALAR EN MODELOS CON KITS DE RISER DE 3" & 6"  
INSTALL IN MODELS WITH 3" & 6" RISER KITS  
INSTALLARE NEI KIT DEI RISER DA 3" e 6"



Ref.	R.O. OEM
RM14865A1	14865A1

**MOTORES / ENGINES / MOTORI**

262, 4.6 (V6) (1996+)

INSTALAR EN MODELOS CON KITS DE RISER DE 3" & 6"  
INSTALL IN MODELS WITH 3" & 6" RISER KITS  
INSTALLARE NEI KIT DEI RISER DA 3" e 6"



Ref.	R.O. OEM
RM807130A4	807130A4 8M0115149 44266T 44266T1

**MOTORES / ENGINES / MOTORI**

"Y" PIPE V6 & V8, Alpha, Bravo  
4.3, 5.0, 5.7, 6.2, 7.4, 8.2L GM  
4.5L MPI  
7° 4" Codos / Elbows / Gomiti



# TAPAS Y JUNTAS CAPS & GASKETS COPERCHI E GUARNIZIONE

## TAPA COLECTOR END CAP MANIFOLD COPERCHIO COLLETTORE

Ref.	R.O. OEM	PARA COLECTORES FOR MANIFOLDS PER COLLETTORI
BA1-47638	47638A1	BAMC-1-63122

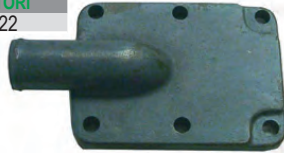

Ref.	R.O. OEM	PARA COLECTORES FOR MANIFOLDS PER COLLETTORI
HGE4870	73813A1	BAMC1-47735
		BAMC1-47736
		BAMC1-47737
		BAMC1-47738
		REC96705A1
		BAMC-1-95862
		HOT20956
BAMC-1-58759		



Ref.	R.O. OEM	PARA COLECTORES FOR MANIFOLDS PER COLLETTORI
REC60252A2	60252A2	REC96705A1
		BAMC-1-58759
		HOT20950
		HOT20951
		BAMC1-47735
		BAMC1-47736
		BAMC1-47737
		BAMC1-47738
		HOT20962
		HOT20958



Ref.	R.O. OEM	PARA COLECTORES FOR MANIFOLDS PER COLLETTORI
REC805629A1	805629A1	BAMC-1-95862 HOT20956



## JUNTAS TAPAS LATERALES LATERAL GASKET CAPS GUARNIZIONE COPERCHIO LATERALE

### TAPA POSTERIOR INTERCAMBIADOR HEAT EXCHANGER END CAP COPERCHIO POSTERIORE SCAMBIATORE

Ref.	R.O. OEM
REC27-99960	27-99960

MOTORES / ENGINES / MOTORI  
224 CID (1976-89)

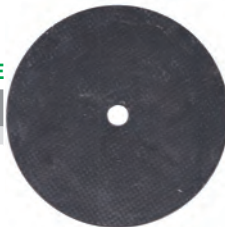

### TAPA DELANTERA INTERCAMBIADOR HEAT EXCHANGER CAP COPERCHIO ANTERIORE SCAMBIATORE

Ref.	R.O. OEM
REC27-75450	27-75450

MOTORES / ENGINES / MOTORI  
224 CID (1976-82)

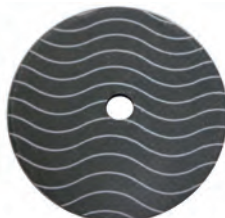

Ref.	R.O. OEM	PARA TAPAS FOR CAPS PER COPERCHIO
REC27-39917	27-39917	BA1-47638

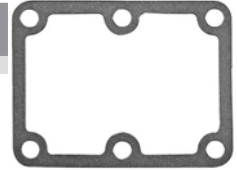

Ref.	R.O. OEM	PARA TAPAS FOR CAPS PER COPERCHIO
BAMC47-27-39923	27-39923	39916
		NO DISPONIBLE NOT AVAILABLE NON DISPONIBILE

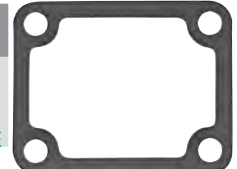

Ref.	R.O. OEM	PARA TAPAS FOR CAPS PER COPERCHIO
REC27-807218	27-807218	HGE4870 REC805629A1



Ref.	R.O. OEM	PARA TAPAS FOR CAPS PER COPERCHIO
REC27-480431	27-480431	REC60252A2

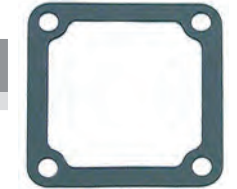

## JUNTAS COLECTOR-CODO MANIFOLD-ELBOW GASKET GUARNIZIONE COLLETTORE-GOMITO

Ref.	R.O. OEM	PARA CODOS FOR ELBOWS PER GOMITI
REC27-39915	27-39915	BAMC-20-55538

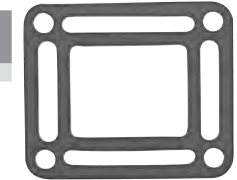

Ref.	R.O. OEM	PARA CODOS FOR ELBOWS PER GOMITI
REC27-99777Q02	27-99777Q02 27-997771 27-997772	HOT20971
		REC76771A2
		MAR076
		REC76325A2

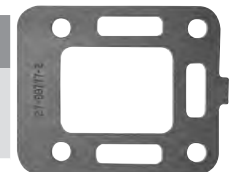

Ref.	R.O. OEM	PARA CODOS FOR ELBOWS PER GOMITI
REC27-18272	27-18272	HOT20937
		ALUMINIO
		ALLUMINIO



Ref.	R.O. OEM	PARA CODOS FOR ELBOWS PER GOMITI
REC27-856705	27-856705 27-97542	HOT20905
		HIERRO
		IRON GHISA



Ref.	R.O. OEM	PARA CODOS FOR ELBOWS PER GOMITI
REC27-8637251	27-8637251 860231 863725	MAR988 REC98504A3

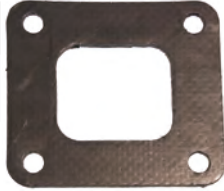

Ref.	R.O. OEM	PARA CODOS FOR ELBOWS PER GOMITI
REC27-48042	27-48042	BAMC20-76668 BAMC20-72963

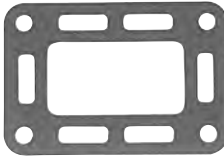

Ref.	R.O. OEM	PARA COLECTORES FOR MANIFOLDS PER COLLETTORI
REC27-8079821	27-8079821 27-70143 27-701431 27-807982	BAMC-1-860235 HOT20956

Para carburadores Mercab  
For Mercab carburators  
Per carburatori Mercab

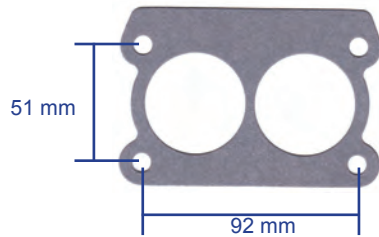

Ref.	R.O. OEM	PARA COLECTORES FOR MANIFOLDS PER COLLETTORI
REC27-64692	27-64692	REC96705A1 BAMC-1-95862

Para carburadores Rochester  
For Rochester carburators  
Per carburatori Rochester

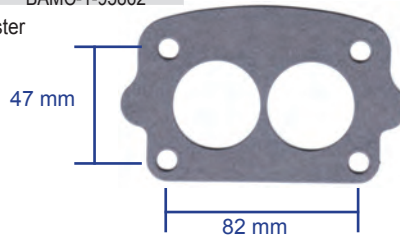

Ref.	R.O. OEM	PARA CODOS FOR ELBOWS PER GOMITI
REC27-863724Q	27-863724Q 27-41813 27-860233 27-863724	MAR988 REC98504A3



Ref.	R.O. OEM	PARA CODOS FOR ELBOWS PER GOMITI
REC27-863726	27-863726 27-871051 27-818832 27-860232	MAR988 REC98504A3



Ref.	R.O. OEM	PARA CODOS FOR ELBOWS PER GOMITI
REC270	27-864547A02 27-864550A02 27-864549A02	MAR309 MAR591



**JUNTAS COLECTOR-CULATA  
MANIFOLD-HEAD GASKET  
GUARNIZIONE COLLETTORE-TESTATA**

Ref.	R.O. OEM	PARA COLECTORES FOR MANIFOLDS PER COLLETTORI
REC27-68715	27-68715	HGE6219-A

**MOTORES / ENGINES / MOTORI**  
MCM 3.7L (4 cyl)



Ref.	R.O. OEM	PARA COLECTORES FOR MANIFOLDS PER COLLETTORI
REC27-52546 FEL17300	27-52546	BAMC-1-63122

**MOTORES / ENGINES / MOTORI**  
GM 153 (4 cyl)



Ref.	R.O. OEM	PARA COLECTORES FOR MANIFOLDS PER COLLETTORI
REC27-53354 FEL17301	27-53354	REC96705A1

**MOTORES / ENGINES / MOTORI**  
GM 181 (4 cyl)



Ref.	R.O. OEM	PARA COLECTORES FOR MANIFOLDS PER COLLETTORI
REC27-96429	27-96429	BAMC-1-95862 HOT20956

**MOTORES / ENGINES / MOTORI**  
GM 153 & 181 (4 cyl)



Ref.	R.O. OEM	PARA COLECTORES FOR MANIFOLDS PER COLLETTORI
REC27-815528 FEL17304	27-815528	BAMC-1-860235

**MOTORES / ENGINES / MOTORI**  
GM 181 (4 cyl)



Ref.	R.O. OEM	PARA COLECTORES FOR MANIFOLDS PER COLLETTORI
FEL17319	27-46401	BAMC-1-58759

**MOTORES / ENGINES / MOTORI**  
GM 250 (6 cyl Inline)



Ref.	R.O. OEM		PARA COLECTORES FOR MANIFOLDS PER COLLETTORI
REC27-99757	27-99757	1	MAR746
FEL17410	27-99757	2	MAR612

**MOTORES / ENGINES / MOTORI**  
GM V6



Ref.	R.O. OEM		PARA COLECTORES FOR MANIFOLDS PER COLLETTORI
REC27-33395	27-33395	1	HOT20735 HOT20950
FEL17420	27-33395	2	HOT20951 MAR246

**MOTORES / ENGINES / MOTORI**  
GM V8 SMALL BLOCK



Ref.	R.O. OEM		PARA COLECTORES FOR MANIFOLDS PER COLLETTORI
REC27-46820	27-46820	1	MAR078 BAMC1-47735
FEL17440	27-46820	2	BAMC1-47736

**MOTORES / ENGINES / MOTORI**  
GM V8 BIG BLOCK



Ref.	R.O. OEM		PARA COLECTORES FOR MANIFOLDS PER COLLETTORI
REC3852455	27-73866	1	HOT20958
FEL17460	27-73866	2	HOT20962

**MOTORES / ENGINES / MOTORI**  
FORD V8 (302, 351)



### FUELLES DE ESCAPE EXHAUST BELLOW CUFFIA DI SCARICO

Ref.	R.O. OEM
REC53114A1	53114A1
CEF500524	53114

**MOTORES / ENGINES / MOTORI**  
120, 140, 160, 165 (GM 181 & 250)  
(1967-82)



Ref.	R.O. OEM
REC70981A3	70981A3
CEF500523	

**MOTORES / ENGINES / MOTORI**  
3" - 4" (76 - 101 mm) I.D



Ref.	R.O. OEM
REC32-90949T	32-90949T
CEF500511K	

**MOTORES / ENGINES / MOTORI**  
3" (76 mm) I.D



Ref.	R.O. OEM
REC32-44348001	32-44348001
CEF500507K	32-44348T 32-44348

**MOTORES / ENGINES / MOTORI**

4" (101 mm) I.D  
Tubo superior / upper tubo / Tubo superiore



Ref.	R.O. OEM
REC32-14358001	32-14358001
CEF500508K	32-14358T 32-14358

**MOTORES / ENGINES / MOTORI**

4" (101 mm) I.D  
Tubo inferior tubo / lower tubo / Tubo inferiore



Ref.	R.O. OEM
REC32-807458T	32-807458T
CEF500532K	

**MOTORES / ENGINES / MOTORI**

4.3L (1996+)  
4" (101 mm) I.D



### PALOMILLAS DE ESCAPE WATER SHUTTER FARFALLA DI SCARICO

Ref.	R.O. OEM
REC99370A2	99370A2

**MOTORES / ENGINES / MOTORI**

3" (76 mm)  
V6-V8 (1982-87)



Ref.	R.O. OEM
REC807166A1	807166A1

**MOTORES / ENGINES / MOTORI**

4" (101 mm)  
V6-V8 (1992+)  
4.5L MPI



Ref.	R.O. OEM	
REC807166A3	807166A3	2
CEF500523	14348A1	

**MOTORES / ENGINES / MOTORI**

4" (101 mm)  
V6-V8 (1992-95)  
D3.0, D3.6, D4.2L



Ref.	R.O. OEM
REC60930	60930

**MOTORES / ENGINES / MOTORI**

4 cyl 140 / 3.0L / 3.0LX  
AJUSTADOS PARA / FITS / SI ADATTA  
V8  
TDI 4.2L (335, 370 MCM/MIE)



# COLECTORES ADMISIÓN INTAKE MANIFOLD COLLETTORE ASPIRAZIONE

Ref.	R.O. OEM	TORNILLOS SCREW VITI
MP425036	824330 824330T	8

**MOTORES / ENGINES / MOTORI**

GM 262, 4.3 (V6)  
VORTEC (4 bbl)  
Hierro / Iron / In ghisa  
(1993+)



Ref.	R.O. OEM	TORNILLOS SCREW VITI
MP425113	811575 811575T 59974	16

**MOTORES / ENGINES / MOTORI**

GM V8 BIG BLOCK 427 & 454 (1969-97)  
GEN IV, V, VI (4 bbl)



Ref.	R.O. OEM	TORNILLOS SCREW VITI
MP425024	824324T 824324	8

**MOTORES / ENGINES / MOTORI**

GM 262, 4.3 (V6)  
VORTEC (2 bbl)  
Hierro / Iron / In ghisa  
(1993+)



Ref.	R.O. OEM	TORNILLOS SCREW VITI
MP425149	72608 72608T	16

**MOTORES / ENGINES / MOTORI**

GM 454, 482, 502  
(1978-97)



Ref.	R.O. OEM	TORNILLOS SCREW VITI
REC425062	807289A1	8

**MOTORES / ENGINES / MOTORI**

GM V8 (350, 5.7)  
VORTEC (4 bbl)  
(1993+)



# TERMOSTATOS THERMOSTATS TERMOSTATI

## KIT CUERPOS TERMOSTATO THERMOSTAT HOUSINGS CORPO TERMOSTATO

Ref.	R.O. OEM
REC87290A23	87290A26

### MOTORES / ENGINES / MOTORI

V6 y V8 bloque pequeño.  
For V6 and V8 small blocks.  
Per V6 e V8 blocco piccolo.

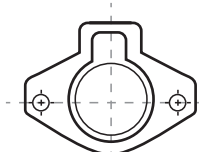

Los agujeros del colector de admisión están a 90° del centro del cigüeñal.  
Intake manifold bolt holes at 90° from the crankshaft centerline.  
I fori del collettore di aspirazione sono a 90° dal centro dell'albero motore.



NOTA: reemplaza a este cuerpo  
NOTE: replaces this housing  
NOTA: sostituisce questo modello

Ref.	R.O. OEM
REC90736A24	90736A24

### MOTORES / ENGINES / MOTORI

V6 y V8 bloque grande.  
For V6 and V8 big blocks.  
Per V6 e V8 blocco grande.

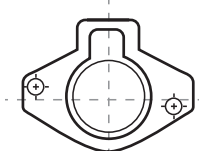

Los agujeros del colector de admisión están a 80° del centro del cigüeñal.  
Intake manifold bolt holes at 80° from the crankshaft centerline.  
I fori del collettore aspirazione sono a 80° dal centro dell'albero motore.



NOTA: reemplaza a este cuerpo  
NOTE: replaces this housing  
NOTA: sostituisce questo modello



## CUERPOS TERMOSTATO THERMOSTAT HOUSINGS CORPO TERMOSTATO

Ref.	R.O. OEM
BAMC29-47587	861493A07
	47587A2
	47587
	861493A3

### MOTORES / ENGINES / MOTORI

GM 153, 181, 250, 292, 120, 140, 2.5L, 3.0, 3.0LX (4 cyl) (1964-97)  
160, 165, 200 (6 cyl) (1967-81)



Ref.	R.O. OEM
REC78984A08	78984A08
	78984A1

### MOTORES / ENGINES / MOTORI

198 MIE (2 bbl) GM 305 V8 (1977)  
228, 228 MIE (4 bbl) GM 305 V8 (1977-80)  
225 MIE GM 350 V-8 (1979-80)  
260 (4 bbl) GM 350 V-8 (1978-82)  
898 (2 bbl) GM 350 V-8 (1977-82)





Ref.	R.O. OEM
REC87290A4	87290A4

**MOTORES / ENGINES / MOTORI**  
4.3L V6 (1983-92)  
5.0 & 5.7L V8 (1981-95)  
Race sterndrive GM454, 502 & 540 (1986-96)

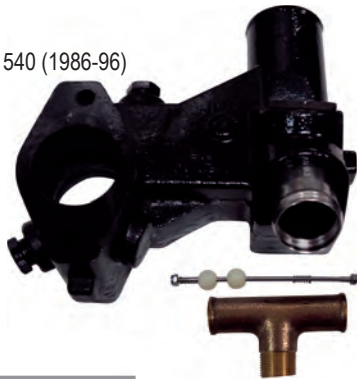

Ref.	R.O. OEM
RM863457A2	863457A2

**MOTORES / ENGINES / MOTORI**  
4.3L, 350 MAG, 5.0L, 6.2L (MPI & MX)  
Todos inyección con 1 o 3 puntos de drenaje.  
All Injection with 1 or 3 point drain system.  
Tutti i motori ad iniezione con 1 o 3 punti di drenaggio.



Ref.	R.O. OEM
BAMC29-63588	889333 63588A1

**MOTORES / ENGINES / MOTORI**  
FORD V8  
302 (1971-77)  
351 (1973-77)



Ref.	R.O. OEM
REC861188A1	861188A1

**MOTORES / ENGINES / MOTORI**  
V6 y V8 con circuito de agua cerrado.  
V6 & V8 with raw water cooling system.  
V6 e V8 con circuito di acqua chiuso.



Ref.	R.O. OEM
BAMC29-78985	78985A1

**MOTORES / ENGINES / MOTORI**  
330 GM454 V8 (1977-81)



Ref.	R.O. OEM
REC55131A5	55131A5

**MOTORES / ENGINES / MOTORI**  
V6 y V8 con circuito de agua cerrado.  
V6 & V8 with raw water cooling system.  
V6 e V8 con circuito di acqua chiuso.



**ACERO INOXIDABLE  
STAINLESS STEEL  
ACCIAIO INOX**

Ref.	R.O. OEM
REC8M0061381	861006A1 8M0061381 860256A4

**MOTORES / ENGINES / MOTORI**  
GM V6 & V8 (305, 350, 357, 383)  
4.3, 5.0, 5.7, 6.2L  
7.4 & 8.2L  
(1998+)

Con cola Bravo. Incluye kit de casquillos para adaptarse a cualquier colector.  
With Bravo sterndrive. Includes bushing kit to fit any manifold.  
Con piede Bravo. Il kit include boccole per adattarsi a qualsiasi collettore.



**EJE VÁLVULA TERMOSTATO  
CHECK BALL KIT  
ALBERINO TERMOSTATO**

Ref.	R.O. OEM
REC30-98475T1	30-98475T1

**MOTORES / ENGINES / MOTORI**  
MCM R/MR/ALPHA ONE (1983-90)

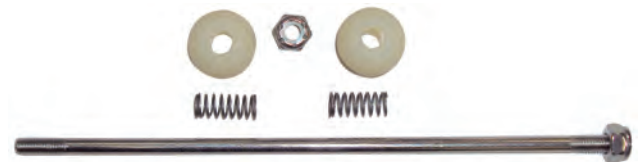

**CASQUILLO TERMOSTATO  
THERMOSTAT SLEEVE  
BOCCOLA TERMOSTATO**

Ref.	R.O. OEM
REC23-806922	23-806922

**MOTORES / ENGINES / MOTORI**  
Para la mayoría de 3.0L, V6, V8  
Fits most 3.0L, V6, V8  
Si adatta maggiormente 3.0L, V6, V8



## VÁLVULA "T" TERMOSTATO TEE VALVE ASSEMBLY VALVOLA "T" TERMOSTATO

Ref.	R.O. OEM	CUERPO DE TERMOSTATO THERMOSTAT HOUSING CORPO TERMOSTATO
REC22-98477A2	22-98477A2	REC87290A4

**MOTORES / ENGINES / MOTORI**  
GM V6 & V8



## MÓDULO DISTRIBUCIÓN DE AGUA WATER DISTRIBUTION MODULE MODULO DISTRIBUZIONE ACQUA

Ref.	R.O. OEM
RM863631T1	863631T1

**MOTORES / ENGINES / MOTORI**  
GM 4.3, 5.0, 5.7 & 6.2L (MPI)  
Drenaje manual  
Manual drain  
Drenaggio manuale



Ref.	R.O. OEM
RM863444T1	863444T1

**MOTORES / ENGINES / MOTORI**  
GM 4.3, 5.0, 5.7 & 6.2L (MPI)  
Varilla accionada  
Rod actuated  
Asta azionata

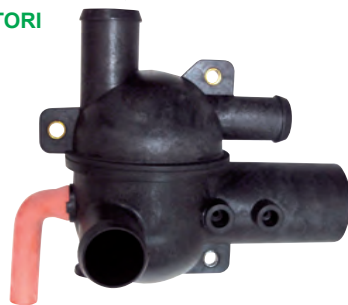

## TAPA TERMOSTATO THERMOSTAT COVER COPERCHIO TERMOSTATO

Ref.	R.O. OEM	CUERPO DE TERMOSTATO THERMOSTAT HOUSING CORPO TERMOSTATO
BAMC29-60372	60372A1 60372A2 861493A07	BAMC29-47587

**MOTORES / ENGINES / MOTORI**  
4 & 6 cyl inline



Ref.	R.O. OEM	CUERPO DE TERMOSTATO THERMOSTAT HOUSING CORPO TERMOSTATO
BAMC29-62898	62898A1 62898 Con colas / With sterndrive / Con Piede	BAMC29-63588
BAMC29-59498	59498 59498A1 Con Eje / With Shaft / Con asse	BAMC29-63588

**MOTORES / ENGINES / MOTORI**  
FORD V8 (302, 351)



Ref.	R.O. OEM	CUERPO DE TERMOSTATO THERMOSTAT HOUSING CORPO TERMOSTATO
REC47441A1	47441A1	REC87290A4

**MOTORES / ENGINES / MOTORI**  
262 V6 / 305, 350 V8 SMALL BLOCK



Ref.	R.O. OEM	CUERPO DE TERMOSTATO THERMOSTAT HOUSING CORPO TERMOSTATO
REC8M0061068	47442A1	BAMC29-78985

**MOTORES / ENGINES / MOTORI**  
454, 502, V8 BIG BLOCK



## JUNTAS TERMOSTATO THERMOSTAT GASKET GUARNIZIONE TERMOSTATO

Ref.	R.O. OEM	CASQUILLO SLEEVE BOCCOLA
REC25-30224	25-30224	REC23-806922
REC27-47510Q	27-47510Q	REC23-47508T



REC25-30224



REC27-47510Q

**CUERPO TERMOSTATO A CULATA  
THERMOSTAT HOUSING TO CYLINDER HEAD  
CORPO TERMOSTATO-TESTATA**

Ref.	R.O. OEM	CUERPO DE TERMOSTATO THERMOSTAT HOUSING CORPO TERMOSTATO
REC27-8146801	27-8146801	BAMC29-47587

**MOTORES / ENGINES / MOTORI**  
4 & 6 cyl inline



**JUNTA A CUERPO TERMOSTATO  
COVER TO THERMOSTAT HOUSING  
DAL COPERCHIO AL CORPO TERMOSTATO**

Ref.	R.O. OEM
REC27-33179Q02	27-33179Q02



Ref.	R.O. OEM
REC17494A1	17494A1

Tapa y junta  
Cover & gasket  
Coperchio e guarnizione

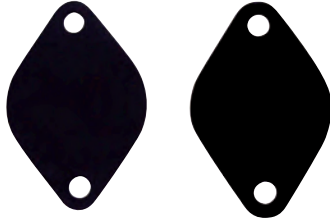

**BY-PASS A TERMOSTATO  
THERMOSTAT TO BY-PASS  
BY-PASS - TERMOSTATO**

Ref.	R.O. OEM
REC27-41812Q	27-41812Q 27-41812

**MOTORES / ENGINES / MOTORI**  
GM V6 / V8 SMALL BLOCK



Ref.	R.O. OEM
REC27-418122	27-418122

**MOTORES / ENGINES / MOTORI**  
GM 454 / 502 V8 BIG BLOCK



Ref.	R.O. OEM
REC27-48818Q01	27-48818Q01

**MOTORES / ENGINES / MOTORI**  
GM V8, SMALL & BIG BLOCK



Ref.	R.O. OEM
REC27-475901	27-47590-1

**MOTORES / ENGINES / MOTORI**  
4 & 6 cyl inline



Ref.	R.O. OEM
REC27-60208Q	27-60208

**MOTORES / ENGINES / MOTORI**  
Ford 302 / 351

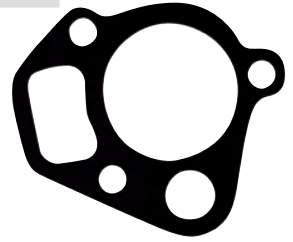

**CUERPO TERMOSTATO A COLECTOR ADMISIÓN  
THERMOSTAT HOUSING TO INTAKE MANIFOLD  
DAL CORPO TERMOSTATO AL COLLETTORE ASPIRAZIONE**

Ref.	R.O. OEM
REC27-53045Q01	27-53045Q01 53051

**MOTORES / ENGINES / MOTORI**  
GM V6 & V8



Ref.	R.O. OEM
REC27-33918	27-8M2021920

**MOTORES / ENGINES / MOTORI**  
GM 4 & 6 cyl inline



Ref.	R.O. OEM
REC27-54506	27-5450

**MOTORES / ENGINES / MOTORI**  
FORD 302/351



Ref.	R.O. OEM
REC27-89656-1	27-89656-1

**MOTORES / ENGINES / MOTORI**  
MCM 470 3,7 L (1976-82)

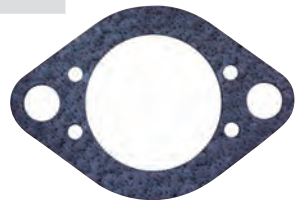

**DEPOSITO A CUERPO TERMOSTATO  
TANK TO THERMOSTAT HOUSING  
DAL SERBATOIO AL CORPO TERMOSTATO**

Ref.	R.O. OEM
REC27-74830	27-74830

**MOTORES / ENGINES / MOTORI**  
MCM 470 3.7L (1976-82)



## TERMOSTATOS Y KITS THERMOSTAT & KITS TERMOSTATI E KIT

Ref.	R.O. OEM	°C
REC59078	59078	140°
REC59078Q3	59078Q3	140° KIT

### MOTORES / ENGINES / MOTORI

4 & 6 cyl inline



REC59078



REC59078Q3

Ref.	R.O. OEM	°C
REC8M0091470	807252T2 8M0091470	160°

### MOTORES / ENGINES / MOTORI

GM V6 & V8, 181°

Modelos modernos / late models / modelli moderni

Inox. / Stainless steel / Inos.



Ref.	R.O. OEM	°C
REC807252Q5	807252Q5	160° KIT

### MOTORES / ENGINES / MOTORI

GM V6 & V8

Mercruiser modernos / late models / I modelli moderni



Ref.	R.O. OEM	°C
REC807252Q3	807252Q3	140° KIT

### MOTORES / ENGINES / MOTORI

FORD V8



Ref.	R.O. OEM	°C
REC99155T2	99155T2	160° KIT

### MOTORES / ENGINES / MOTORI

4 cyl 224 (3.7L)

Motores con colector escape de aluminio y circuito de refrigeración cerrado.  
Engines with closed cooling & aluminum exhaust manifold

Motori con circuito di refrigerazione chiuso e colettore di scarico in alluminio

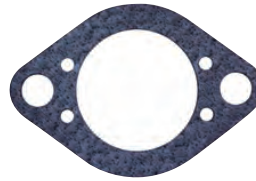

Ref.	R.O. OEM	°C
REC8M0089715	807252T1 8M0089715	140°

### MOTORES / ENGINES / MOTORI

GM V6 & V8, Ford V8



Ref.	R.O. OEM	°C
REC807252Q4	807252Q4 807252T4	140° KIT

### MOTORES / ENGINES / MOTORI

GM V6 & V8



Ref.	R.O. OEM	°C
REC864493	864493	170°

### MOTORES / ENGINES / MOTORI

4.3L CARB ALPHA / BRAVO

4.3L MPI ALPHA / BRAVO

4.5L MPI

350 MAG MPI ALPHA / BRAVO

357 HRZ

377 MAG MPI

5.0L MPI ALPHA / BRAVO

5.7L MPI

6.2L MPI

**NEW**



# BOMBAS DE AGUA WATER PUMPS POMPE ACQUA

Ref.	R.O. OEM
PH600-0004	884727 8M0113733

**MOTORES / ENGINES / MOTORI**  
GM 4 & 6 CYL INLINE



Ref.	R.O. OEM
PH600-0005	8503991 8M0113734

**MOTORES / ENGINES / MOTORI**  
GM V6 & V8 SMALL BLOCK



Ref.	R.O. OEM
PH600-0002	8504541

**MOTORES / ENGINES / MOTORI**  
GM V8 BIG BLOCK



Ref.	R.O. OEM
PH600-0003	883925 8M0113736

**MOTORES / ENGINES / MOTORI**  
GM 8.1L



Ref.	R.O. OEM
PH600-0006	883885

**MOTORES / ENGINES / MOTORI**  
FORD V8 302,351



Ref.	R.O. OEM
REC879194401	46-879194401 8M0094406 8M6005225

**MOTORES / ENGINES / MOTORI**

V6 (2007+) Sin bypass / without water bypass hole / senza bypass  
MCM MPI (OW658583+)  
MCM Carb. (1A063240+)



Ref.	R.O. OEM	IMPULSOR IMPELLER GIRANTE
RM46-807151A8	46-807151A8 46-72774A69	REC47-59362Q01

**MOTORES / ENGINES / MOTORI**

Mercuriser 454 Magnum 7.4 & 502  
Con acople bomba gasolina.  
Includes fuel pump adapter.  
Con accoppiamento pompa benzina.  
GEN V & VI (1992-99)



Ref.	R.O. OEM	KIT REPARACIÓN REPAIR KIT KIT RIPARAZIONE	IMPULSOR IMPELLER GIRANTE
SHEG155	806152	SHE15979	REC47-59362Q01

**MOTORES / ENGINES / MOTORI**

Mercuriser 7.3L Diesel  
7.3L (BRAVO & MIE)  
DIESEL NAV 444 V-8 (1994-96)  
(OF060000+)



Ref.	R.O. OEM	IMPULSOR IMPELLER GIRANTE
SHEG151	805835	SHE15000K

**MOTORES / ENGINES / MOTORI**

7.3L (BRAVO & MIE) DIESEL NAV444 V-8 (1994-96)  
D7.3L D-TRONIC 260LD (1999)  
D 7.3L D-TRONIC 300 (1999)

**NEW**



Ref.	R.O. OEM	IMPULSOR IMPELLER GIRANTE
REC46-807151A9	46-807151A9	REC47-59362Q01

**MOTORES / ENGINES / MOTORI**

De bronce con tornillería inox. Motores V6 y V8 con correa serpentin. Sea Water Pump. Brass assembly with stainless steel fittings for V6 & V8 engines with serpentine belt.  
In bronzo con viteria inox. Motori V6 e V8 con cinghia serpentina.

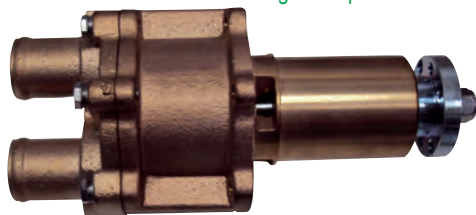

POLEA PULLEY PULIGGIA	R.O. OEM
REC861579	861579 807731T



Ref.	R.O. OEM	IMPULSOR IMPELLER GIRANTE
REC46-862914T10	46-862914T10	REC47-862232A2

**MOTORES / ENGINES / MOTORI**

4.3L MPI, 5.0L MPI, 350 MAG MPI & MX, 8.2L MAG  
6.2L MPI con / with / con ECM 555  
De bronce con tornillería inox.  
Brass assembly with stainless steel fittings.  
In bronzo con viteria inox.



POLEA PULLEY PULIGGIA	R.O. OEM
REC862351T	862351T



Ref.	R.O. OEM	IMPULSOR IMPELLER GIRANTE
SHEP1016	854179001	SHE10615K

**MOTORES / ENGINES / MOTORI**

MERCURUISER CUMMINS MARINE  
CMD 2.8 Ei, ES (170/200)  
CMD QSD 2.8 Ei, ES (170/210/220/230)  
CMD QSD 2.0 Ei, ES (115/130/150)



Ref.	R.O. OEM	IMPULSOR IMPELLER GIRANTE
REC46-72774A32	46-807151A12	REC47-59362Q01 REC47-59362A4 (KIT)
	46-72774A32	
	46-59112A2	
	46-63450A2	
	46-72774A11 46-73823A7	

**MOTORES / ENGINES / MOTORI**

De bronce con tornillería inox. Motores V6 & V8 con correa "V"  
Brass assembly with stainless steel fittings for V6 & V8 engines with V-belt.  
In bronzo con viteria inox Motori V6 & V8 con cinghia a "V".

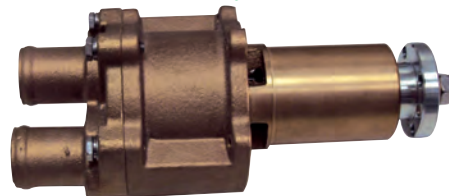

Ref.	R.O. OEM	IMPULSOR IMPELLER GIRANTE
SHEG2603X		SHE26000K

**MOTORES / ENGINES / MOTORI**

Cummins Diesel



**JUNTAS BOMBA AGUA  
SEA WATER GASKET  
GUARNIZIONE POMPA DELL'ACQUA**

Ref.	R.O. OEM	BOMBA PUMP POMPA
REC27-803192A2	24-803192A2	PH600-0002

**MOTORES / ENGINES / MOTORI**

454-502 CHEVY

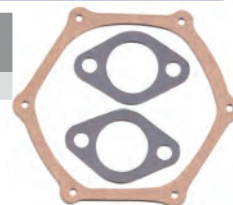

Ref.	R.O. OEM	BOMBA PUMP POMPA
REC27-56880	27-56880	PH600-0006

**MOTORES / ENGINES / MOTORI**

Ford V8 (302, 351)



Ref.	R.O. OEM	BOMBA PUMP POMPA
REC27-33956	27-33956	PH600-0004

**MOTORES / ENGINES / MOTORI**

4 & 6 Cyl.

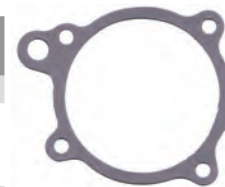

Ref.	R.O. OEM	BOMBA PUMP POMPA
REC27-34897	27-34897	PH600-0005

**MOTORES / ENGINES / MOTORI**

GM V6 & V8 Bloque pequeño / Small block / blocco piccolo



Ref.	R.O. OEM	BOMBA PUMP POMPA
REC27-49110	27-49110	PH600-0002

**MOTORES / ENGINES / MOTORI**

V-8 Bloque grande / big block / blocco grande  
454-502 CHEVY



# MOTORES DE ARRANQUE STARTERS MOTORINO D'AVVIAMENTO

Ref.	R.O. OEM	V	DIENTES TOOTH DENTI	KW	VOLANTE FLYWHEEL VOLANTE	SOLENOIDE SOLENOID SOLENOIDE
PH140-0017-D	50-863007A1	12	11	1.4	14"	PH375-0008

## MOTORES / ENGINES / MOTORI

4 cyl V6 & V8  
3.0L

Motor de arranque para substituir a todos los motores de tamaño pequeño con tornillos fijación en diagonal excepto los 7.4L

Starter to replace all the little engines with diagonally fixation screws exepcting 7.4L.

Motorino d'avviamento per sostituire tutti i motori V6 e V8 con motorini con viti di supporto trasversali eccetto i motori 7.4L.

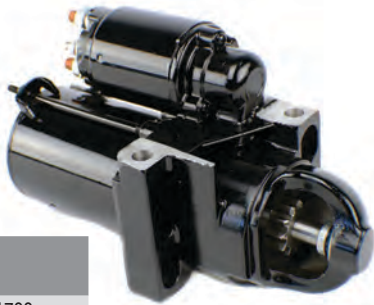

TORNILLO BOLT VITE	R.O. OEM
REC10-861788	10-861788

Ref.	R.O. OEM	V	DIENTES TOOTH DENTI	KW	VOLANTE FLYWHEEL VOLANTE	SOLENOIDE SOLENOID SOLENOIDE
PH140-0017-HT	50-864340A2	12	11	1.7	14"	PH375-0005

## MOTORES / ENGINES / MOTORI

Motor de arranque Heavy Duty. Tornillos de fijación en diagonal. Para todos los motores V-6 y V-8, y especialmente los 7.4 L.

Starter with diagonally fixation screws. For all engines V6 & V8, specially 7.4L.

Motorino d'avviamento Heavy Duty con viti di supporto trasversali. Per tutti i motori V-6 e V-8, consigliato per i 7.4L.



TORNILLO BOLT VITE	R.O. OEM
REC10-861788	10-861788

Ref.	R.O. OEM	V	DIENTES TOOTH DENTI	SOLENOIDE SOLENOID SOLENOIDE
PH140-0004	50-69865A1 50-12782 50-56886	12	10	PH375-0009

## MOTORES / ENGINES / MOTORI

FORD 5.0 & 5.8L

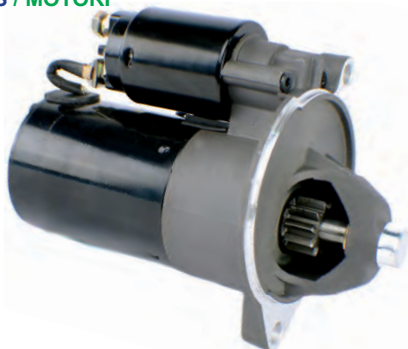

Ref.	R.O. OEM	V	DIENTES TOOTH DENTI	VOLANTE FLYWHEEL VOLANTE	SOLENOIDE SOLENOID SOLENOIDE
PH140-0015	50-864340A2 50-99418A2	12	9	14 <sup>1/4"</sup>	PH375-0004

## MOTORES / ENGINES / MOTORI

Motor de arranque para V6 y V8 con tornillos sujección en diagonal.

Starter to V6 & V8 heavy duty standard rotation. Offset mounting holes

Motorino d'avviamento per V6 e V8 con viti di supporto trasversali.



TORNILLO BOLT VITE	R.O. OEM
REC10-861788	10-861788

Ref.	R.O. OEM	V	DIENTES TOOTH DENTI	KW	VOLANTE FLYWHEEL VOLANTE	SOLENOIDE SOLENOID SOLENOIDE
PH140-0020	50-863007A1 50-806963A2 50-806965A4	12	9	1.4	12 <sup>3/4"</sup>	PH375-0008

## MOTORES / ENGINES / MOTORI

V6 & V8

Motor de arranque pequeño 4 en línea.

Starter Clockwise for 4L.

Motorino d'avviamento (viti di supporto trasversali).



TORNILLO BOLT VITE	R.O. OEM
MP0180-001	

REC10-861788	10-861788
--------------	-----------

Ref.	R.O. OEM	V	DIENTES TOOTH DENTI	KW	SOLENOIDE SOLENOID SOLENOIDE
PH140-0020-D	50-812429A2 50-806965A2 50-806965A4 50-8M0090697	12	11	1.4	PH375-0008

## MOTORES / ENGINES / MOTORI

3.0L

NEW



TORNILLO BOLT VITE	R.O. OEM
MP0180-001	

REC10-861788	10-861788
--------------	-----------

Ref.	R.O. OEM	V	DIENTES TOOTH DENTI	SOLENOIDE SOLENOID SOLENOIDE
PH140-0013	50-806965A4 50-99417A2	12	9	PH375-0004

**MOTORES / ENGINES / MOTORI**

Modelo antiguo. Motor de arranque 4 en línea, V6 & V8 (Tornillos sujeción misma altura).

Old style. Starter heavy duty standard rotation 4 inline, V6 & V8. In line mounting holes.

Modello vecchio. Motorino d'avviamento 4 in linea, V6 & V8 (Viti di supporto parallele)



TORNILLO BOLT VITE	R.O. OEM
MP0180-000	10-812509184
REC10-861788	10-861788



Ref.	R.O. OEM	V	DIENTES TOOTH DENTI
PH150-0008	50-805991	12	10

**MOTORES / ENGINES / MOTORI**

7.3L BRAVO & MIE  
DIESEL NAV444 V8 (1994-96)  
6.9L



Ref.	R.O. OEM	V	DIENTES TOOTH DENTI	KW
PH140-0022	50-72550A2 50-47454 50-65785A1 50-79604A3	12	9	1.4

**MOTORES / ENGINES / MOTORI**

4, 6 & 8 cyl

Motor de arranque 4 en línea modelo 470.

Starter clockwise 4 in line 470 mod. and engines with transmission.

Motorino d'avviamento 4 in linea modello 470.



Ref.	R.O. OEM	V	DIENTES TOOTH DENTI	KW
PH140-0022-CCW	50-808011A05 50-88671A1 50-80811A4	12	9	1.4

**MOTORES / ENGINES / MOTORI**

4, 6 & 8 cyl

5.7 MIE / 6.2 MIE.

Contrarrotación o montaje en campana.

Starter counter clockwise.

Controrrotante, posizionato nella campana.



**EXTENSOR DE SOLENOIDE PARA TERMINALES  
SOLENOID EXTENSOR FOR TERMINALS  
PROLUNGA TERMINALE PER SOLENOIDE**

Ref.	R.O. OEM
PH365-0006	





# ALTERNADORES, REGULADORES Y TRIM ALTERNATORS, VOLTAGE REGULATORS & TRIM ALTERNATORI, REGOLATORI E TRIM

136

MERCURISER

## ALTERNADOR ALTERNATOR ALTERNATORI

Ref.	R.O. OEM	V
PH300-0013	78403A2	12V 61A
	59755	
	69729	
	56045	

Regulador autoexcitante  
Polea simple  
1 cable  
Self-exciting regulator  
Single pulley  
1 wire  
Regolatore  
Singola puleggia  
1 cavo



Ref.	R.O. OEM	V
PH300-0022	817119A4	12V 63A
	78402	
	78403A1	
	78403A2	
	92497A3	

Regulador autoexcitante  
Polea simple  
2 cable  
Self-exciting regulator  
Single pulley  
2 wire  
Regolatore  
Singola puleggia  
2 cavo



Ref.	R.O. OEM	V
PH300-0034	862031T1	12V 70A
	862031	
	862031T	
	862031T	

**MOTORES / ENGINES / MOTORI**  
4.3 & 5.7L (1997+)

Regulador interno  
Polea serpentín 6 canales 65 mm  
Internal regulator  
6 groove pulley 65 mm  
Regolatore interno  
Puleggia a serpentina a 6 canali. 65 mm



Ref.	R.O. OEM	V
PH300-0010	817119A4	12V 55A
	98555	
	12449	
	19685	
	817119	
	817119A1	

**MOTORES / ENGINES / MOTORI**  
4.3 & 5.7L (1998+)

Regulador interno  
Polea simple  
Internal regulator  
Single pulley  
Regolatore interno  
Puleggia singola



Ref.	R.O. OEM	V
PH300-0016	805884T	12V 65A
	805884	
	805447T	
	805447T	

**MOTORES / ENGINES / MOTORI**  
Para gasolina inyección y diesel.  
Regulador interno  
Polea simple  
For EFI & diesel engines.  
Internal regulator  
Single pulley  
Per motori benzina iniezione e diesel.  
Regolatore interno  
Puleggia singola



Ref.	R.O. OEM	V
PH300-0033	862030T01	12V 70A
	862030T	

**MOTORES / ENGINES / MOTORI**  
3.0L (1999+)

Regulador interno  
Polea simple  
Internal regulator  
Single pulley  
Regolatore interno  
Puleggia singola



Ref.	R.O. OEM	V
PH300-0012	807653T	12V 65A
	807653	

Regulador interno  
Polea serpentín 6 canales  
Internal regulator  
6 groove pulley  
Regolatore interno  
Puleggia a serpentina a 6 canali.



Ref.	R.O. OEM	V
PH300-0011	807652T	12V 55A
	807652	

Regulador interno  
Polea serpentín 6 canales  
Internal regulator  
6 groove pulley  
Regolatore interno  
Puleggia a serpentina a 6 canali.



Ref.	R.O. OEM	V
PH300-0035	863077T 86307AR01	12V 70A

**MOTORES / ENGINES / MOTORI**  
4.3L, 6.2L & 5.7L (1995+)

Regulador interno  
Polea serpentín 6 canales 50 mm  
Internal regulator  
6 groove pulley 50 mm  
Regolatore interno  
Puleggia a serpentinaa 6 canali. 50 mm



Ref.	R.O. OEM	V
REC882571	882571 8M0084523	12V 50A

**MOTORES / ENGINES / MOTORI**  
MCM 1.7L DTI.  
CMD 1.7 MI 120 L/L4  
CMD 1.7 MS 120L/L4

6 Polea serpentín 50 mm  
6 groove pulley 50 mm  
Puleggia a serpentina a 6 canales. 50 mm

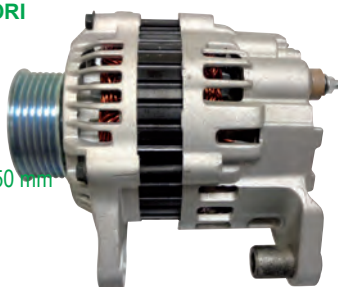

Ref.	R.O. OEM	V
PH300-0030	834832 834832T2 857006A3	12V 50A

**MOTORES / ENGINES / MOTORI**  
RACE STERNDRIVE 500EFI, 575 SCI

Regulador interno  
Polea serpentín 4 canales  
Internal regulator  
4 groove pulley  
Regolatore interno.  
Puleggia a serpentina a 4 canali



**KIT SUSTITUCIÓN ALTERNADOR**  
**ALTERNATOR CONVERSION KIT**  
**KIT SOSTITUZIONE ALTERNATORE**

Ref.	R.O. OEM	V
REC18-5953	42785	12V 68A

**MOTORES / ENGINES / MOTORI**  
470 (3.7L)  
224 (3.7L)



**REGULADOR ALTERNADOR**  
**VOLTAGE REGULATOR**  
**REGOLATORE ALTERNATORE**

Ref.	R.O. OEM
REC42785	42785

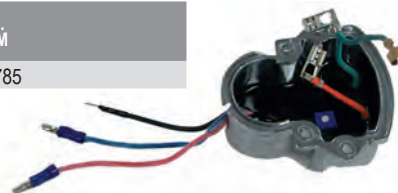

**MOTORES TRIM**  
**TRIM ENGINES**  
**MOTORI TRIM**

Ref.	R.O. OEM
PH200-T016-SK	414336A6 14336A9 88183A12



Motor Trim completo con soporte inox. Incluye motor, solenoides, fusible y cableado. Complete bracket assembly with Tilt/Trim motor, solenoids, fuse block and wiring. Stainless steel bracket. Motore trim completo di supporto in acciaio inox. Include il motore, solenoide, fusibile e cablaggio. (1983+) Quick connect



Ref.	R.O. OEM	V
PH200-T016	865380A13 865380A25 88183A12 14336A8 14336A20	12V

Motor Trim completo con depósito. Oildyne Complete for late -MCM. Motore trim completo con serbatoio.



Ref.	R.O. OEM	V
PH200-T015	891736T 17649 17649T	12V

3 cables de conexión. Para Alpha I, Gen II y Bravo. 3 wire connection For late style Alpha I, II gen & Bravo drives. 3 cavi di connessione Per Alpha I, Gen II e Bravo.



**CONVERTIDOR DE 3 A 2 CABLES**  
**3 TO 2 WIRE WIRED CONVERTER**  
**CONVERTITORE CAVI DA 3 A 2 FILI**

Ref.
PH200-WH01



Ref.	R.O. OEM
------	-------------

PH200-T066-K 865380A13

Soporte motor Trim fabricado en acero inox. Incluye solenoides, fusible y cableado.  
Bracket assembly with solenoids, fuse block and wiring. Stainless steel bracket.  
Supporto motorino Trim in acciaio inox. Include i solenoidi, fusibile e cablaggio.



**NEW**

Ref.	R.O. OEM
------	-------------

PH200-T066 862548A1  
42419A1

Bracket motor Trim.  
Fabricado en acero inox.  
Supporto motorino trim in acciaio inox



Ref.	R.O. OEM
------	-------------

PH200-T064-1B 18525A1

Depósito Trim 1 tornillo.  
One Bolt Reservoir.  
Vaschetta Trim 1 vite.



Ref.	R.O. OEM
------	-------------

REC883166A2 883166A2

Depósito Trim 4 tornillos.  
Four bolt Reservoir.  
Vaschetta Trim 4 viti.



ACEITE TRIM / TILT  
POWER TRIM & TILT FLUID  
OLIO TRIM / TILT  
LUB11578U12



## SOLENOIDES Y FUSIBLES SOLENOID & FUSES SOLENOIDI E FUSIBILE

### SOLENOIDES SOLENOID SOLENOIDI

Ref.	R.O. OEM	V
PH375-0036	89-818999A2	12
	89-818999A1	
	89-805188A1	



### SOLENOIDES ARRANQUE STARTER SOLENOID SOLENOIDI AVVIAMENTO

Ref.	R.O. OEM	V
REC89-96054T	89-96054T	12
	89-96054	
	89-91975	
REC89-818864T	89-818864T	12
	89-818864	
PH375-0027	87-76416A1	12
PH375-0011	25661T1	12
	25661	
PH375-0031	65057T1	12
	65057A1	



REC89-96054T

### SOLENOIDES TRIM TRIM SOLENOID SOLENOIDI TRIM

Ref.	R.O. OEM	V
PHSEL-239	89-96158T	12
	89-96158	
PH375-0028	89-853654A1	12
	89-68258A4	
PH375-0034	89-818997T1	12
	89-818997A1	



PHSEL-239



PH375-0028



PH375-0034



REC89-818864T



PH375-0027



PH375-0011



PH375-0031

**SOLENOIDES DELCO REMY**  
**DELCO REMY SOLENOID**  
**SOLENOIDE DELCO REMY**

Ref.	R.O. OEM	V
PH375-0001	13037	12 9.5 cm
	8733261	
	89-853654A1	
PH375-0004	89-18080	12 7.5 cm
	89-99253	
PH375-0008	809463A1	12



PH375-0008



PH375-0001  
PH375-0004

**RELÉ ARRANQUE Y BOMBA GASOLINA**  
**RELAY FOR IGNITION & FUEL PUMP**  
**RELÉ DI AVVIAMENTO, E POMPA BENZINA**

Ref.	R.O. OEM
REC86-865202T	86-865202T



**RELÉ PARA ACELERADOR Y EJE**  
**RELAY FOR THROTTLE AND SHIFT**  
**RELÉ DI ACCELERATORE E ASSE**

Ref.	R.O. OEM
REC882751A04	882751A04

**MOTORES / ENGINES / MOTORI**  
 496 MAG (BASE & H.O.)  
 8.1L INBOARD (BASE & H.O.)  
 8.1L TOWSPORT  
 Relay para cable mecánico  
 Relay for mechanical wire  
 Relé per cavo meccanico



**NEW**

Ref.	R.O. OEM
REC882751A1	882751A1
	828151
	828151A1
	882751A2

**MOTORES / ENGINES / MOTORI**  
 8.2L INBOARD (BASE & H.O.) EC  
 8.2L MAG  
 Relay para cable digital y mecánico  
 Relay for digital & mechanical cable  
 Relé per cavo digitale e meccanico



**NEW**

**RELÉ PARA ALARMA Y VARIOS**  
**RELAY FOR ALARM & OTHERS**  
**RELÉ PER ALARMA E ALTRI**

Ref.	R.O. OEM
REC821509	821509
	821509T01

**MOTORES / ENGINES / MOTORI**  
 CMD 2.8 EI, ES (165)  
 CMD 4.2 EI, ES, MI, MS (200, 230, 250, 300)  
 D2.8L/165 D-TRONIC  
 D3.0L, D3.6L, D4.2L/(200, 220, 250, 300)



**NEW**

**FUSIBLE MOTOR**  
**CIRCUIT BREAKER**  
**FUSIBILE MOTORE**

Ref.	R.O. OEM	V
BS2142	88-11178A01	50A
BS2143	88-93582	60A



**FUSIBLE MOTOR TRIM**  
**TRIM FUSE ASSEMBLY**  
**FUSIBILE MOTORINI TRIM**

Ref.	R.O. OEM	V
PH365-0003	88-79023T10	110A
RM88-79023A91	88-79023A91	90A



**FUSIBLE ATM**  
**ATM FUSE**  
**FUSIBILE ATM**

Ref.	AMP	
AM603905	5 A	2
AM603910	10 A	2
AM603915	15 A	2
AM603920	20 A	2
AM603930	30 A	2



**FUSIBLE ATC**  
**ATC FUSE**  
**FUSIBILE ATC**

Ref.	AMP	
BS5291	3 A	2
BS5299	4 A	2
BS5292	5 A	2
BS5293	7,5 A	2
BS5294	10 A	2
BS5295	15 A	2
BS5296	20 A	2
BS5297	25 A	2
BS5298	30 A	2



**FUSIBLE MAXI**  
**MAXI FUSE**  
**FUSIBILE MAXI**

Ref.	AMP	
BS5138	30 A	2
BS5139	40 A	2
BS5140	50 A	2
BS5141	60 A	2
BS5142	70 A	2
BS5143	80 A	2



# FILTROS MOTORES GASOLINA FILTERS GAS ENGINE FILTRI MOTORI BENZINA



## FILTRO COMBUSTIBLE SEPARADOR DE AGUA WATER SEPARATING FUEL FILTER FILTRO SEPARATORE ACQUA-BENZINA

Ref.	R.O. OEM	MICRAS MICRON	ALTURA HEIGHT ALTEZZA
REC24942	35-802893Q01	10	4 7/16"
REC35-802893Q01	35-802893Q01	10	3 3/4"
REC855686	35-802893Q01	28	4 7/16"
REC35-802893Q	35-802893Q01	25	3 3/4"
RACPF5510	35-802893Q01	10	4 7/16"



REC24942

REC855686

REC35-802893Q01



REC35-802893Q



RACPF5510

Ref.	R.O. OEM
RM35-866594Q01	35-866594Q01 35-866594K01

### MOTORES / ENGINES / MOTORI 3.0L MPI EC

No compatible con carburadores:  
Not compatible with carburetors:  
Non compatibile con carburatori:  
100VAZER, 100VAZER EC



### FILTRO ORIGINAL OEM FILTER FILTRO BENZINA ORIGINALE

Ref.	R.O. OEM	MICRAS MICRON	ALTURA HEIGHT ALTEZZA
RM35-802893Q	35-802893Q01	10	3 3/4"



## FILTRO CON BRACKET FILTER WITH BRACKET FILTRO CON SUPPORTO

Ref.	R.O. OEM	MICRAS MICRON	TOMAS NTPF PORTS FILETTO	FLUJO FLOW FLUSSO
REC24950	35-60494A4	28	1/4"	50GPH
REC24952		10	1/4"	50GPH

Bracket de Aluminio. Con 2 tapones de bronce y 1 tubo de extensión.  
Cast Aluminium Bracket. With 2 brass plugs & 1 extension tube.  
Supporto in alluminio. Con 2 tappi di bronzo e 1 tubo di estensione.



Ref.	R.O. OEM
RAC320R-RAC-02	35-802893Q4
RAC320R-RAC-03	
RACS3220UL	35-809101

Con Bracket Inox y cubeta metálica.  
With Stainless Steel Bracket and metallic bowl.  
Con Bracket e vaschetta metallica.



RAC320R-RAC-02

RAC320R-RAC-03

RACS3220UL

Recambio filtro.  
Element.  
Cartuccia filtro.

## BRACKET BRACKET SUPPORTO

Ref.	R.O. OEM	BRACKET	TOMAS NTPF PORTS FILETTO
REC25000	89876A3	AL	1/4"
REC25010		INOX AISI316	1/4"
REC25020		AL	3/8"
REC25030		INOX AISI316	3/8"

Con 2 tapones de bronce y 2 tubos de extensión.  
(2 entradas y 2 salidas).  
With 2 brass plugs and 2 extension tubes.  
(2 inputs & 2 outputs).  
Con 2 tappi di bronzo e 2 tubi di estensione.  
(2 ingressi entrata carburante e 2 uscite carburante).



REC25000 - REC25020



REC25010 - REC25030

RÁCORES  
RACORS  
RACCORDI



Ref.	ROSCA THREAD PASSO	MANGUERA HOSE TUBO	
GS31066	1/4" NPT	5/16" = 7,9 mm	2
GS31067	1/4" NPT	3/8" = 9,5 mm	2

Fabricado en latón.  
Made in machined brass.  
Prodotto in ottone



Ref.	ROSCA THREAD PASSO	MANGUERA HOSE TUBO	
GS31065	1/4" NPT	3/8" = 9,5 mm	2
GS31166	1/4" NPT	5/16" = 7,9 mm	2
GS31155	3/8" NPT	3/8" = 9,5 mm	2
GS31156	3/8" NPT	5/16" = 7,9 mm	2
GS31157	3/8" NPT	1/4" = 6,4 mm	2

Rácor 90° fabricado en latón.  
Made in machined brass.  
Raccordo 90° prodotto in ottone



FILTROS DECANTADORES  
COMPLETE FUEL FILTERS  
FILTRI DECANTATORE



	RAC120R-RAC-01	RAC320R-RAC-01	RAC320R-INOX-01	RAC320R-RAC-02
FLUJO MÁXIMO MAX. FLOW FLUSSO MASSIMO	114 l/h 30 gph	340 l/h 60 gph	340 l/h 60 gph	340 l/h 60 gph
ELEMENTO / ELEMENT / ELEMENTO	RACS3240	RACS3213	RACS3213	RACS3220UL
CAZOLETA TRANSPARENTE (sólo se recomienda para fueraborda.) CLEAR BOWL (Just for outboards) VASCHETTA TRASPARENTE (Solo nei fuoribordo.)	✓	✓	✓	✗
ROSCAS CENTRALES CENTRAL THREADS FILETTO CENTRALE	M18 x 1.5	1 1/4"	1 1/4"	1 1/4"
TAMAÑO ROSCA CABEZA HEAD PORT SIZE DIMENSIONE VITE TESTA	1/4-18 NPTF	1/4-18 NPTF	1/4-18 NPTF	1/4-18 NPTF
ALTURA X ANCHO X PROF. HEIGHT X WIDTH X DEPTH ALTEZZA X LARGH X PROF.	16 x 81 x 81 mm	238 x 102 x 102 mm	238 x 102 x 102 mm	238 x 102 x 102 mm
PESO / WEIGHT / PESO	0,5 kg	0,9 kg	0,9 kg	0,9 kg
CAIDA DE PRESIÓN PRESSURE DROP CADUTA DI PRESSIONE	0.15 PSI 0.01 bar	0.61 PSI 0.04 bar	0.61 PSI 0.04 bar	0.61 PSI 0.04 bar
PRESIÓN MÁXIMA MAX. PRESSURE PRESSIONE MASSIMA	7 PSI 0.05 bar	7 PSI 0.05 bar	7 PSI 0.05 bar	7 PSI 0.05 bar
DESMONTAJE CARTUCHO-CAZOLETA ELEMENT REMOVAL UNDERBOWL RIMOZIONE DELLA CARTUCCIA	25,4 mm 1"	25,4 mm 1"	25,4 mm 1"	25,4 mm 1"
TEMPERATURA DE TRABAJO OPERATING TEMPERATURE TEMPERATURA DI LAVORO			-40°C +124°C -40°F +255°F	

ELEMENTOS DE RECAMBIO  
ELEMENT  
ELEMENTI DI RICAMBIO

Ref.	R.O. OEM	FILTRO FILTER FILTRO
RACS3240		RAC120R-RAC-01
LENS3240		
RACS3227	35-886638	
LENS3227		
RACS3213	35-809097	RAC320R-RAC-01
LENS3213		RAC320R-RAC-01 INOX
RACS3214	35-809099	
RACS3228UL		RAC320R-RAC-02, con/with/con bracket RACOR
RACS3220UL		RAC320R-RAC-02



LENS3240  
LENS3227  
LENS3214



RACS3240  
RACS3227  
RACS3214



RACS3228UL

**FILTROS GASOLINA  
FUEL FILTERS  
FILTRI BENZINA**



Ref.	R.O. OEM
REC864572	864572 35-864572

**MOTORES / ENGINES / MOTORI**  
EFI & MPI, 8.1L & 496 CID  
3/8" ID línea de combustible / fuel lines / 3/8 línea carburante  
MPI & EFI con bomba boost / boost pump / pompa di sovralimentazione



Ref.	CAPACIDAD CAPACITY CAPACITÀ	MANGUERA HOSE TUBO
GS31001	50 l/h	6 - 8 mm
GS31102	150 l/h	8 - 10 mm



GS31001

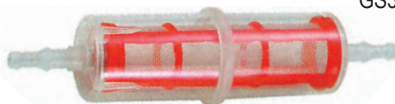

GS31002

Ref.	R.O. OEM
RAC31871	35-884380T
	35-8M0020349
	35-8M0060041

**MOTORES / ENGINES / MOTORI**  
MCM 4.5L (V6)



Ref.	R.O. OEM
REC35-8M0046752	35-8M0046752
	35-11004A1
	35-803897Q1

**MOTORES / ENGINES / MOTORI**  
2.5L/3.0L (6229718+)  
MCM224 CID (6218037+)  
GM262 CID (A331455+)  
con carter de bomba de combustible  
with carter fuel pump  
con carter pompa combustibile



Ref.	R.O. OEM
REC1397-8767Q	1397-8767Q
	1397-8767
	1397-8545

**MOTORES / ENGINES / MOTORI**  
GM 2.5L/3.0L (6229718+)  
GM 5.0L/5.7L (6218462+)  
205 (A331455+)  
228 HP (6021784+)  
330 HP (6083145+)  
GM 255 (590768+)  
5.7L SKI 340, 230 & 260 inboards

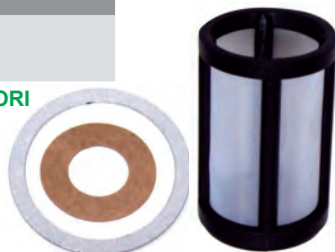

Ref.	R.O. OEM
REC35-866171A01	35-866171A01

**MOTORES / ENGINES / MOTORI**  
5.0 - 350 - 6.2 & 8.1 MPI, MIE  
496 MAG  
con módulo de bomba combustible  
with fuel pump module  
con modulo pompa combustibile



**CUBETA FILTRO GASOLINA  
FUEL FILTER BOWL  
VASCHETTA FILTRO BENZINA**

Ref.	R.O. OEM
REC35-892665	35-892665

**MOTORES / ENGINES / MOTORI**  
5.0 (350, 377, 383, 496)  
6.2 & 8.1 MPI



**FILTRO GASOLINA CARBURADOR  
CARBURETOR FUEL FILTER  
FILTRO BENZINA CARBURATORE**

Ref.	R.O. OEM
REC35-53336	35-53336Q
	35-53336
	3302-9033

**MOTORES / ENGINES / MOTORI**  
GM INLINE 4 & 6 cyl  
FORD & GM V8 400 HP+  
MERCURUISER 224 CID



REC93568

Ref.	R.O. OEM	CARBURADOR CARBURETOR CARBURATORE
REC93568	35-93568	Rochester 2bbl & 4 bbl
REC35-49088A2	35-49088Q2	4 & 6 cyl inline
	35-49088A2	
REC1397-2150	1397-2150	Rochester



REC35-49088A2



REC1397-2150

**FILTROS VST  
VST FILTERS  
FILTRI VST**



Ref.	R.O. OEM
REC65L-13915-00	808504
	8085041
	808504T1

**MOTORES / ENGINES / MOTORI**  
262 MAG (TBI) GEN+  
350 MPI, TBI, EFI (1994-96)  
454 EFI (GEN V) GM (1994-96)  
454 EFI (SKI GEN V) GM (1995)  
454 MAG BRAVO MPI (GEN VI) GM (1996-97)  
5.7 EFI (TBI) GM 350 V8 (1995)  
7.4L MIE MPI (LH) (GEN V) GM (1995-96)  
7.4L MIE MPI (LH) (GEN VI) GM (1996-97)  
7.4LX BRAVO MPI (GEN V) GM (1996)  
7.4LX BRAVO MPI (GEN VI) GM (1996-97)  
8.2L MIE MPI (LH) (GEN VI) GM (1996-97)



**JUNTA SEPARADOR DE VAPOR  
VAPOR SEPARATOR TANK O-RING  
GUARNIZIONE SEPARATORE DI VAPORE**

Ref.	R.O. OEM
REC808500	808500

**MOTORES / ENGINES / MOTORI**  
V6 & V8

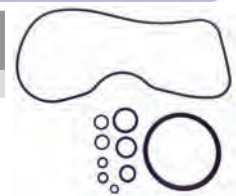

**FILTROS AIRE**  
**GAS ENGINE AIR FILTERS**  
**FILTRI ARIA**



Ref.	R.O. OEM
RM35-863829	35-863829

**MOTORES / ENGINES / MOTORI**

350 MAG	4.3L MPI
383 MAG	5.0L MPI
496 MAG	6.2L MPI
357 HRZ	



Ref.	R.O. OEM
RM35-8M2001030	35-8M2001030

**MOTORES / ENGINES / MOTORI**

350 MAG MPI	5.0L MPI
377 MAG MPI	5.7L MPI
4.3L MPI	6.2L MPI

**FILTROS ACEITE**  
**GAS ENGINE OIL FILTERS**  
**FILTRI OLIO**



Ref.	R.O. OEM	MOTORES ENGINES MOTORI	ROSCA THREAD FILETTO
RM35-883702Q	35-883702Q	V6 GM MCM V-6 *	18 mm x 1.5
RM35-866340Q02	35-866340Q03	GM 4 inline, V8 MCM / MIE GM V-6 *	13/16" x 16 NPT

\* sin filtro de aceite remoto  
 \* without oil remote filter  
 \* senza filtro dell'olio remoto



Ref.	R.O. OEM	MOTORES ENGINES MOTORI	ROSCA THREAD FILETTO
REC35-06004	35-883702Q	GM V6	18 mm x 1.5
REC35-06003	35-866340Q03	GM 4 inline V8	13/16" x 16 NPT
REC35-06007	35-802886Q, 60565	V8 Ford	3/4" x 16 NPT



**FILTROS MOTORES DIESEL**  
**FILTERS DIESEL ENGINE**  
**FILTRI MOTORI DIESEL**



**FILTROS GASOIL**  
**DIESEL FILTERS**  
**FILTRI DIESEL**



Ref.	R.O. OEM
REC882376	882376

**MOTORES / ENGINES / MOTORI**

1.7DTI Original



Ref.	R.O. OEM
REC35-19486	35-19486

**MOTORES / ENGINES / MOTORI**

D254  
 D3.0L  
 D3.6L  
 D4.2L



Ref.	R.O. OEM
REC35-808275	35-808275

**MOTORES / ENGINES / MOTORI**

D7.3/270 Bravo  
 & MIE Diesel (1994-96)



Ref.	R.O. OEM
REC35-807256	35-807256T

**MOTORES / ENGINES / MOTORI**

D3.0L  
 D3.6L  
 D7.3L D-Tronic  
 CMD 2.8  
 CMD 4.2  
 D2.8L





Ref.	R.O. OEM
REC35-879172104	35-879172104

**MOTORES / ENGINES / MOTORI**

(MQSD MODELS)

2.0L  
2.8L  
4.2L  
base VM



**FILTROS CON CAZOLETA Y ELEMENTOS  
BOWL FILTERS & ELEMENTS  
FILTRI CON VASCHETTA E ELEMENTI**



	RAC500MA30	RAC900MA30	RAC1000MA30	RAC75/500MAX	RAC75/1000MA30
FLUJO MÁXIMO MAX. FLOW FLUSSO MASSIMO	227 l/h 60 gph	341 l/h 90 gph	681 l/h 180 gph	454 l/h 120 gph	681 / 1363 l/h 180 / 360 gph
ELEMENTO ELEMENT ELEMENTO	<b>2010</b>	<b>2040</b>	<b>2020</b>	<b>2010</b>	<b>2020</b>
ALTURA X ANCHO X PROF. HEIGHT X WIDTH X DEPTH ALTEZZA X LARGH X PROF.	292 x 147 x 122 mm	432 x 152 x 178 mm	559 x 152 x 178 mm	292 x 368 x 241 mm	559 x 476 x 279 mm
TAMAÑO ROSCA CABEZA HEAD PORT SIZE DIMENSIONE VITE TESTA	1/4-18 NPTF	1/4-18 NPTF	1/4-18 NPTF	1/4-18 NPTF	
PESO WEIGHT PESO	2 kg	3 kg	5 kg	7,7 kg	13,6 kg
CAIDA DE PRESIÓN PRESSURE DROP CADUTA DI PRESSIONE	0.61 PSI 0.04 bar	0.34 PSI 0.02 bar	0.49 PSI 0.03 bar	0.70 PSI 0.05 bar	3.70 PSI 0.25 bar
PRESIÓN MÁXIMA MAX. PRESSURE PRESSIONE MASSIMA	15 PSI 1 bar	15 PSI 1 bar	15 PSI 1 bar	15 PSI 1 bar	15 PSI 1 bar
ALTURA CLEARN. ALTEZZA	102 mm	127 mm	254 mm	102 mm	254 mm

**ELEMENTOS DE RECAMBIO**

**ELEMENT  
ELEMENTI DI RICAMBIO**

REF	REF	REF	MICRAS MICROM MICRON
500	900	1000	
RAC2010SM-OR	RAC2040SM-OR	RAC2020SM-OR	2
RAC2010TM-OR	RAC2040TM-OR	RAC2020TM-OR	10
RAC2010PM-OR	RAC2040PM-OR	RAC2020PM-OR	30

S: secundario  
T: primario o secundario/final  
P: primario

S: secondary final  
T: primary or secondary final  
P: primary

S: secundario  
T: primario o secundario  
P: primario



# FILTROS DECANTADOR COMPLETE DIESEL FILTER FILTRI DECANTATORE



	RAC110A	RAC120AS	RAC230R2	RAC245R2	RAC460R2	RAC490R2
FLUJO MÁXIMO MAX. FLOW FLUSSO MASSIMO	57 l/h 15 gph	57 l/h 15 gph	114 l/h 30 gph	170 l/h 45 gph	227 l/h 60 gph	341 l/h 90 gph
ELEMENTO ELEMENT ELEMENTO	RACR11T	RACR12	RACR20	RACR25	RACR60	RACR90
DIESEL	✓	✓	✓	✓	✓	✓
GASOLINA GAS BENZINA	✓	✓				
CAZOLETA TRANSPARENTE CLEAR BOWL VASCHETTA TRASPARENTE	✗	✓	✓	✓	✓	✓
INSTALACIÓN VACUÓMETRO VACUUM INSTALLATION INSTALLAZIONE VACUOMETRO	✓	✓	✓	✓	✓	✓
INSTALACIÓN PRESIÓN PRESSURE INSTALLATION INSTALLAZIONE PRESSIONE	✓	✓	✓	✓	✓	✓
ALTURA X ANCHO X PROF. (mm) HEIGHT X WIDTH X DEPTH (mm) ALTEZZA X LARGH X PROF. (mm)	152 x 81 x 81	165 x 81 x 81	229 x 102 x 102	267 x 102 x 102	279 x 114 x 121	300 x 114 x 121
PESO WEIGHT PESO	0,59 kg	0,59 kg	0,90 kg	1 kg	1,3 kg	1,4 kg
CAIDA DE PRESIÓN PRESSURE DROP CADUTA DI PRESSIONE	0.15 PSI 0.01 bar	0.15 PSI 0.01 bar	0.31 PSI 0.02 bar	0.61 PSI 0.04 bar	0.39 PSI 0.03 bar	0.95 PSI 0.06 bar
PRESIÓN MÁXIMA MAX. PRESSURE PRESSIONE MASSIMA	100 PSI	7 PSI	30 PSI	30 PSI	30 PSI	30 PSI
TAMAÑO ENTRADA INLET SIZE DIMENSIONI ENTRATA	1/4" NPT	1/4" NPT	1/4" NPT	1/4" NPT	3/8" NPT	3/8" NPT
BOMBA CEBADO (SÓLO PARA DIESEL) PRIMER PUMP (ONLY DIESEL) POMPA (SOLO PER DIESEL)	✗	✗	✓	✓	✓	✓
Nº TOMAS NUM. OF PORTS Nº FORI	4	4	3	3	4	4
TIPO DRENAJE DRAIN TYPE TIPO DRENAGGIO	Sello positivo Positive seal Tenuta positiva	Sello positivo Positive seal Tenuta positiva	Sello positivo Positive seal Tenuta positiva	Sello positivo Positive seal Tenuta positiva	Sello positivo Positive seal Tenuta positiva	Sello positivo Positive seal Tenuta positiva
OPCIÓN SENSOR AGUA WATER SENSOR OPTION OPZIONE SENSORE ACQUA	✗	✓	✓	✓	✓	✓

## ELEMENTOS DE RECAMBIO

### ELEMENTI DI RICAMBIO

REF.	MICRAS MICROM MICROM
RACR11T	10



REF.	MICRAS MICROM MICROM
RACR12S	2
RACR12T	10
RACR12P	30



REF.	MICRAS MICROM MICROM
RACR20S	2
RACR20T	10
RACR20P	30



REF.	MICRAS MICROM MICROM
RACR24S	2
RACR24T	10
RACR24P	30



REF.	MICRAS MICROM MICROM
RACR25S	2
RACR25T	10
RACR25P	30



REF.	MICRAS MICROM MICROM
RACR26S	2
RACR26T	10
RACR26P	30



REF.	MICRAS MICROM MICROM
RACR60S	2
RACR60T	10
RACR60P	30



REF.	MICRAS MICROM MICROM
RACR90S	2
RACR90T	10
RACR90P	30



S: secundario  
T: primario o secundario/final  
P: primario

S: secondary final  
T: primary or secondary final  
P: primary

S: secondario  
T: primario o secundario  
P: primario

FILTRO COMPLETO COMPLET FILTER FILTRO COMPLETO	CARTUCHO RECAMBIO REPLACEMENT ELEMENT CARTICCIA DI RICAMBIO	MICRAS MICROM MICROM
RAC245R2	RACR25S RACR25T	2 10



Filtro decantador Racor con bracket  
Water separating diesel filter with bracket  
Filtro decantatore Racor completo

FILTRO COMPLETO COMPLET FILTER FILTRO COMPLETO	CARTUCHO RECAMBIO REPLACEMENT ELEMENT CARTICCIA DI RICAMBIO	FLUJO FLOW FLUSSO
REC1140639	REC3581078	50 l/h



**RECmar**

FILTRO FILTER FILTRO	CARTUCHO RECAMBIO REPLACEMENT ELEMENT CARTICCIA DI RICAMBIO	FLUJO FLOW FLUSSO
REC120	RACR12	15 gph



**NEW**

**RECmar**



**FILTRO TRANSMISION HURTH  
FILTER HURTH TRANSMISSION  
FILTRO TRASMISSIONE HURTH**

Ref.	R.O. OEM
REC016940	879194241 35-815419

**RECmar**

**MOTORES / ENGINES / MOTORI**  
Mercuriser V8 Hurth Transmission  
8.1L & 8.2L Inboard  
ZEUS 3000

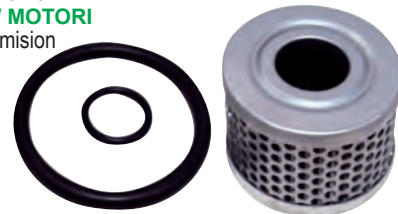

**FILTROS ACEITE  
GAS ENGINE OIL FILTERS  
FILTRI OLIO**



Ref.	R.O. OEM	ROSCA THREAD FILETTO
REC3517857	35-803470 35-80470Q	3/4" x 16 NPT

**NEW**

**MOTORES / ENGINES / MOTORI**  
60 & 80 HP (RENAULT)  
Filtro corto / Short filter / filtro corto



Ref.	R.O. OEM	ROSCA THREAD FILETTO
REC3850559	35-16595T1 35-16595Q 35-52731	13/16" x 16 NPT

**NEW**

**MOTORES / ENGINES / MOTORI**  
GM  
Filtro largo / Long filter / Filtro lungo

- 230 CID 370
- 250 CID 400
- 198 GM 420
- 228 GM 440
- 150 GM 460
- 330 898
- 350



**FILTROS TIPO SEPAR 2000  
FILTER TYPE SEPAR 2000  
FILTRI DI TIPO SEPAR 2000**



Ref.	MICRAS MICROM MICROM	FLUJO FLOW FLUSSO	MEDIDAS MEASURE MISURE	PARA FOR PER
RECGS00530	10	300 l/h	75 x 75 x 24 3 1/16 x 3 1/8 x 1 3/16	SWK-2000/5/50
RECGS01030	30	600 l/h	88 x 88 x 55 3 9/16 x 3 5/8 x 2 1/8	SWK-2000/10
RECGS01830	30	1080 l/h	136 x 138 x 55 5 13/16 x 5 7/8 x 2 1/8	SWK-2000/18/130 (4 units)

**NEW**



RECGS00530

RECGS01830

RECGS01030

**RECmar**

Ref.	R.O. OEM
REC127695-35150	35-19485

**NEW**

**MOTORES / ENGINES / MOTORI**

- 530D
- 636D
- D2.8L
- D3.0L
- D3.6L
- D4.2L
- Motors VM engines



Ref.	R.O. OEM
REC35-805809	35-805809 35-805809T

MOTORES / ENGINES / MOTORI  
D7.3L



Ref.	R.O. OEM
REC35-816168	35-816168

MOTORES / ENGINES / MOTORI  
D254  
D3.0L  
D3.6L  
D4.2L



Ref.	R.O. OEM
REC882687	882687

MOTORES / ENGINES / MOTORI  
1.7DTS



Ref.	R.O. OEM
REC895207	895207

MOTORES / ENGINES / MOTORI  
CUMMINS 2,8L  
CMD, QSD  
2.0 / 2.8 / 4.2



## FILTROS AIRE GAS ENGINE AIR FILTERS FILTRI ARIA



Ref.	R.O. OEM
REC35-19487	35-19487

MOTORES / ENGINES / MOTORI  
530D D219  
636D D254  
D183 D7.3L



Ref.	R.O. OEM
REC35-805312	35-805312

MOTORES / ENGINES / MOTORI  
D2.8L D4.2L  
D254 CMD MODELS



## RÁCORES PARA FILTROS RACORS FOR FILTER RACCORDI PER FILTRO



RECTOS  
STRAIGHT  
DRITTO

Ref.	MANGUERA TUBE TUBO	
GS30430	8 mm	2
GS30431	10 mm	2



ORIENTABLES  
GUIDEBLE  
REGOLABILE

Ref.	MANGUERA TUBE TUBO	
GS30432	8 mm	2
GS30433	10 mm	2

Para el filtro: REC1140639.  
For REC1140639 filter.  
Per filtri REC1140639



Ref.	ROSCA THREAD FILETTO	MANGUERA TUBE TUBO	PARA FILTROS FOR FILTERS PER FILTRI
RAC913-O10-H10	7/8" - 14	5/8" = 16 mm	900 & 1000MA30
RAC913-O10-H8	7/8" - 14	1/2" = 13 mm	900 & 1000MA30
RAC913-O8-H6	3/4" - 16	3/8" = 10 mm	500MA30
RAC913-O8-H8	3/4" - 16	1/2" = 13 mm	500MA30

Fabricado en latón.  
Para filtros RACOR.  
Made in machined brass.  
For RACOR filters.  
In ottone. Per filtri RACOR



Ref.	ROSCA THREAD FILETTO	MANGUERA TUBE TUBO
BRA125-3/16x1/4	1/4"	3/16"
BRA125-1/4x1/2	1/2"	1/4"
BRA125-5/16x3/8	3/8"	5/16"
BRA125-3/8x3/8	3/8"	3/8"
BRA125-3/8x1/2	1/2"	3/8"
BRA125-1/2x3/8	3/8"	1/2"
BRA125-1/2x1/2	1/2"	1/2"
BRA125-1/2x3/4	3/4"	1/2"
BRA125-5/8x3/8	3/8"	5/8"
BRA125-5/8x1/2	1/2"	5/8"
BRA125-5/8x3/4	3/4"	5/8"
BRA125-3/4x1/2	1/2"	3/4"
BRA125-3/4x3/4	3/4"	3/4"
BRA125-1x3/4	3/4"	1"



Ref.	ROSCA THREAD FILETTO	MANGUERA TUBE TUBO	
GS31166	1/4"	5/16" = 7,9 mm	2
GS31155	3/8"	3/8" = 95 mm	2
GS31156	3/8"	5/16" = 7,9 mm	2



Ref.	ROSCA THREAD FILETTO	MANGUERA TUBE TUBO
RAC1/2x16	1/2"	16 mm
RAC1/2X18	1/2"	18 mm
RAC1/2X20	1/2"	20 mm
RAC3/8X10	3/8"	10 mm
RAC3/8X12	3/8"	12 mm
RAC3/8X14	3/8"	14 mm

Fabricado en latón. Para filtros RACOR 500, 900, 1000.

Made in machined brass. For RACOR filters 500, 900, 1000.

In ottone. Per filtri RACOR 500, 900, 1000.



Ref.	ROSCA EXT THREAD EXT FILETTO EST	ROSCA INT THREAD INT FILETTO INT	PARA FILTROS FOR FILTERS PER FILTRI
RAC1/2F-1/2M	7/8"	1/2"	900 & 1000
RAC3/8F-3/8M	3/4"	3/8"	500

Fabricado en latón.  
Made in machined brass.  
In ottone.

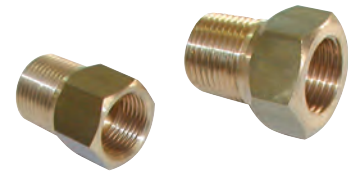

## ACCESORIOS PARA FILTROS FILTERS ACCESSORIES ACCESSORI PER FILTRI

### EXTRACTOR DE FILTROS OIL FILTER WRENCH ESTRATTORE DI FILTRI

Ref.	PARA FILTROS FOR FILTERS PER FILTRI
REC70720	65 - 110 mm

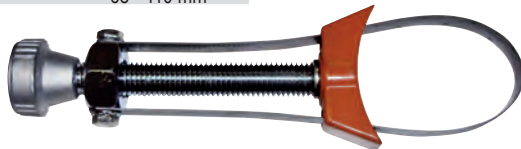

### RELOJ SENSOR DE AGUA WATER ALARM ALLARME SENSORE ACQUA

Ref.
RACRK20726



### VALVULA DRENAJE AGUA DE FILTROS RACOR DRAIN VALVE FOR RACOR FILTERS VALVOLA DRENAGGIO ACQUA PER FILTRI RACOR

Ref.
RACRK19492UL



### SENSOR DE AGUA WATER SENSOR SENSORE ACQUA



Ref.
RECRK21069

Sólo para filtros Diesel.  
No utilizar con gasolina.  
Only for diesel applications.  
Do not use with gasoline.  
Solo per filtri Diesel.  
NON benzina



### MANÓMETRO VACUUM GAUGE MANOMETRO

Ref.
RAC1606B



# UNIDADES DE TRANSMISIÓN TRANSMISSION UNITS UNITÀ DI TRASMISSIONE

**RECMAR®**

## BRAVO I

### PARTE INFERIOR COMPLETA COMPLETE GEAR HOUSING ASSEMBLY PARTE INFERIORE COMPLETA

Ref.	R.O. OEM	ENTRADAS DE AGUA WATER INTAKE PRESA D'ACQUA
REC1656-8866A55	1656-8866A55 1656-8866A10	1
REC1656-8866A63	1656-8866A63 1656-8866A15	2



## R / MR / ALPHA ONE

### COLA COMPLETA COMPLETE DRIVE SHAFT PIEDE COMPLETO

R.O. COLA COMPLETA STD COMPLETE DRIVE SHAFT OEM STD R.O. PIEDE COMPLETO STD	REDUCCIÓN RATIO RIDUZIONE	MOTOR ENGINE MOTORE	PARTE SUPERIOR UPPER HOUSING PARTE SUPERIORE	PARTE INFERIOR STD LOWER HOUSING STD PARTE INFERIORE STD (13/21 THEETH 1972-92)
5-5010147CP	1.47, 1.50 (20/22)	V8 (-300HP)	REC1547-9412A20	REC1623-8951A43
5-5010162CP	1.62, 1.65 (24/24)	6 Cyl en línea / in-line / in rete	REC1547-9412A21	
5-5010181CP	1.81, 1.84 (17/19)	V6 & 470/485	REC1547-9412A22	
5-5010194CP	1.94, 1.98 (20/24)	4 Cyl en línea / in-line / in rete	REC1547-9412A23	
R.O. COLA COMPLETA C.R. COMPLETE DRIVE SHAFT OEM C.R. R.O. PIEDE COMPLETO C.R.	REDUCCIÓN RATIO RIDUZIONE	MOTOR ENGINE MOTORE	PARTE SUPERIOR UPPER HOUSING PARTE SUPERIORE	PARTE INFERIOR C.R. LOWER HOUSING C.R. PARTE INFERIORE C.R.
5-5000147CP	1.47, 1.50 (20/22)	V8 (-300HP)	REC1547-9412A20	REC1623-8951A33
5-5000162CP	1.62, 1.65 (24/24)	6 Cyl en línea / in-line / in rete	REC1547-9412A21	
5-5000181CP	1.81, 1.84 (17/19)	V6 & 470/485	REC1547-9412A22	
5-5000194CP	1.94, 1.98 (20/24)	4 Cyl en línea / in-line / in rete	REC1547-9412A23	

Se suministra en dos piezas sin tornillos de unión ni ánodos.  
Para una instalación completa pida las siguientes referencias:  
Supplied in 2 pieces without union screws nor anodes.  
For a complete installation ask for the following references:  
Fornito in due pezzi senza viti di unione e senza anodi.  
Per un'installazione completa richiedere i seguenti riferimenti:

Ref.	Descripción	Description	Descrizione	CANTIDAD QUANTITY QUANTITÀ
REC10-30206	TORNILLO	SCREW	VITE	1
REC11-34933	TUERCA	NUT	DADO	5
CMALPHAGEN1KITA	KIT ANODOS	ANODES KIT	KIT ANODI	1

### PARTE SUPERIOR COMPLETA COMPLETE DRIVE SHAFT HOUSING PARTE SUPERIORE COMPLETA

Ref.	R.O. OEM	REDUCCIÓN RATIO RIDUZIONE	MOTOR ENGINE MOTORE
REC1547-9412A20	1547-9412A20	1.50, 1.47 (20/22)	V8 (-300 HP) 9-9/16" new style input yoke
REC1547-9412A21	1547-9412A21	1.65, 1.62 (24/24)	6 Cyl en línea / inline / in linea 9-9/16" new style input yoke
REC1547-9412A22	1547-9412A22	1.84, 1.81 (17/19)	V6 & 470/485 9-9/16" new style input yoke
REC1547-9412A23	1547-9412A23	1.98, 1.94 (20/24)	4 Cyl en línea / inline / in linea 9-9/16" new style input yoke



MC1 / R / MR / ALPHA ONE

PARTE INFERIOR COMPLETA. ROTACIÓN ESTÁNDAR  
COMPLETE GEAR HOUSING ASSEMBLY. STANDARD ROTATION  
PARTE INFERIORE COMPLETA. ROTAZIONE STANDAR

Ref.	R.O. OEM	Nº SERIE SERIAL No No. SERIE
REC1623-8951A43	1623-8951A43	6225577+

MOTORES / ENGINES / MOTORI

(1972-92)  
13 estriás Eje. Dientes 13/21  
13 spline Drive shaft. Tooth count 13/21  
Asse a 13 scalanature. Ingranaggi 13/21 denti

PARTE INFERIOR COMPLETA. CONTRARROTACIÓN  
COMPLETE GEAR HOUSING ASSEMBLY. OPPOSITE ROTATION  
PARTE INFERIORE COMPLETA. CONTROROTANTE

Ref.	R.O. OEM	Nº SERIE SERIAL No No. SERIE
REC1623-8951A33	1623-8951A33	6225577+

CARCASA PARTE INFERIOR (Sin componentes)  
GEAR HOUSING (Without components)  
CARCASSA PARTE INFERIORE (Senza componenti)

Ref.	R.O. OEM	Nº SERIE SERIAL No No. SERIE
REC1623-5356A4	1623-5356A4	1 & R
REC1623-8951A37	1623-8951A37	Alpha One & MR



ALPHA ONE GEN II

COLA COMPLETA  
COMPLETE DRIVE SHAFT  
PIEDE COMPLETO

R.O. COLA COMPLETA STD COMPLETE DRIVE SHAFT OEM STD R.O. PIEDE COMPLETO STD	REDUCCIÓN RATIO RIDUZIONE	MOTOR ENGINE MOTORE	PARTE SUPERIOR UPPER HOUSING PARTE SUPERIORE	PARTE INFERIOR STD LOWER HOUSING STD PARTE INFERIORE STD
5-5121200TP	1.47 (20/22)	5.0L EFI 5.7 / 350 MAG (MPI) -300HP	REC1547-861063A12	REC1623-815822A53
5-5121300TP	1.62 (24/24)	4.3 LH / 4.3L EFI / 5.0L (MPI)	REC1547-861063A10	
5-5121400TP	1.81 (17/19)	4.3L / 4.3LX (MPI)	REC1547-861063A8	
5-5121500TP	1.94 (20/24)	3.0L / 3.0LX (MPI)	REC1547-861063A6	
R.O. COLA COMPLETA C.R. COMPLETE DRIVE SHAFT OEM C.R. R.O. PIEDE COMPLETO C.R.	REDUCCIÓN RATIO RIDUZIONE	MOTOR ENGINE MOTORE	PARTE SUPERIOR UPPER HOUSING PARTE SUPERIORE	PARTE INFERIOR C.R. LOWER HOUSING C.R. PARTE INFERIORE C.R.
5-5111200TP	1.47 (20/22)	5.0L EFI 5.7 / 350 MAG (MPI) -300HP	REC1547-861063A12	REC1623-815822A47
5-5111300TP	1.62 (24/24)	4.3 LH / 4.3L EFI / 5.0L (MPI)	REC1547-861063A10	
5-5111400TP	1.81 (17/19)	4.3L / 4.3LX (MPI)	REC1547-861063A8	
5-5111500TP	1.94 (20/24)	3.0L / 3.0LX (MPI)	REC1547-861063A6	

Se suministra en dos piezas sin tornillos de unión ni ánodos.  
Para una instalación completa pida las siguientes referencias:  
Supplied in 2 pieces without union screws nor anodes.  
For a complete installation ask for the following references:  
Fornito in due pezzi senza viti di unione e senza anodi.  
Per un'installazione completa richiedere i seguenti riferimenti:

Ref.	Descripción	Description	Descrizione	CANTIDAD QUANTITY QUANTITÀ
REC11-859135	TUERCA	NUT	DADO	4
REC10-816601	TORNILLO	SCREW	VITE	4
REC12-45176	ARANDELA	WASHER	RONDELLA	4
REC23-816583	TUBO AGUA	WATER TUBE	TUBO ACQUA	1
CMALPHAKITA	KIT ANODOS	ANODES KIT	KIT ANODI	1

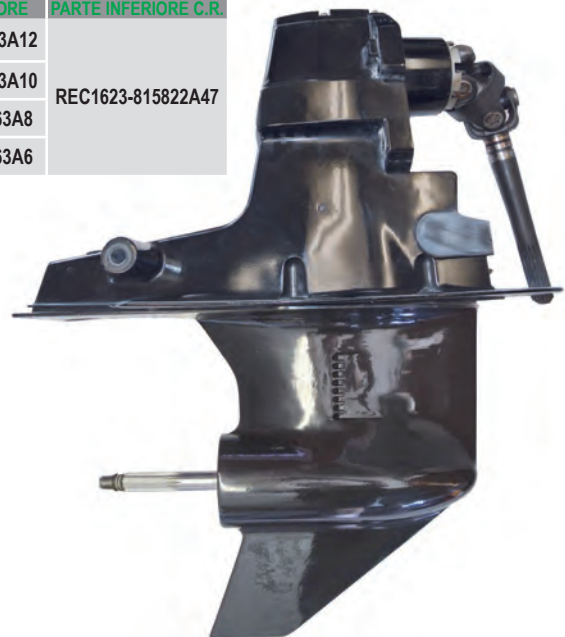

**PARTE SUPERIOR COMPLETA**  
**COMPLETE DRIVE SHAFT HOUSING**  
**PARTE SUPERIORE COMPLETA**

Ref.	R.O. OEM	REDUCCIÓN RATIO RIDUZIONE	MOTOR ENGINE MOTORE
REC1547-861063A12	1547-861063A12	1.47 (20/22)	5.0L EFI / 5.7 / 350 MAG
REC1547-861063A10	1547-861063A10	1.62 (24/24)	4.3LH / 4.3L EFI / 5.0L
REC1547-861063A8	1547-861063A8	1.81 (17/19)	4.3L / 4.3LX
REC1547-861063A6	1547-861063A6	1.94 (20/24)	3.0L / 3.0LX



**CARCASA PARTE SUPERIOR** (Sin componentes)  
**DRIVE SHAFT HOUSING** (Without components)  
**CARCASSA PARTE SUPERIORE** (Senza componenti)

Ref.	R.O. OEM
REC1547-815930A7	1547-815930A7

OD469859-OK999999, (1991-97)

**PARTE INFERIOR COMPLETA**  
**COMPLETE GEAR HOUSING ASSEMBLY**  
**PARTE INFERIORE COMPLETA**

PARTE INFERIOR STD LOWER HOUSING STD PARTE INFERIORE STD	R.O. OEM	REDUCCIÓN RATIO RIDUZIONE	MOTOR ENGINE MOTORE
REC1623-815822A53	1623-815822A53 1623-815822A43 1623-815823A5 1623-815822A32	No reemplaza unidades de ratio 2.00 o 2.40 Will not replaces 2.00 or 2.40 ratio units Non sostituisce le unità di ratio 2.00 o 2.40	OD469859+
REC1623-815822A55 <b>NEW</b>	1623-815822A45 1623-815822A55	Sólo para ratios 2.00 & 2.40 (14/28 dientes) Only for ratio 2.00 & 2.40 ratio units (14/28 teeth) Solamente per ratio 2.00 e 2.40 (14/28 denti)	OL100040+ (1998+)

PARTE INFERIOR C.R. LOWER HOUSING C.R. PARTE INFERIORE C.R.	R.O. OEM	REDUCCIÓN RATIO RIDUZIONE	MOTOR ENGINE MOTORE
REC1623-815822A47	1623-815822A47	No reemplaza unidades de ratio 2.00 o 2.40 Will not replaces 2.00 or 2.40 ratio units Non sostituisce le unità di ratio 2.00 o 2.40	OD469859+

**CARCASA PARTE INFERIOR** (Sin componentes)  
**GEAR HOUSING** (Without components)  
**CARCASSA PARTE INFERIORE** (Senza componenti)

Ref.	R.O. OEM
REC1623-815822A30	1623-815822A30
	1623-815822A36

OD469859-OK999999





R / MR / ALPHA ONE  
(6225577 - OD469858)

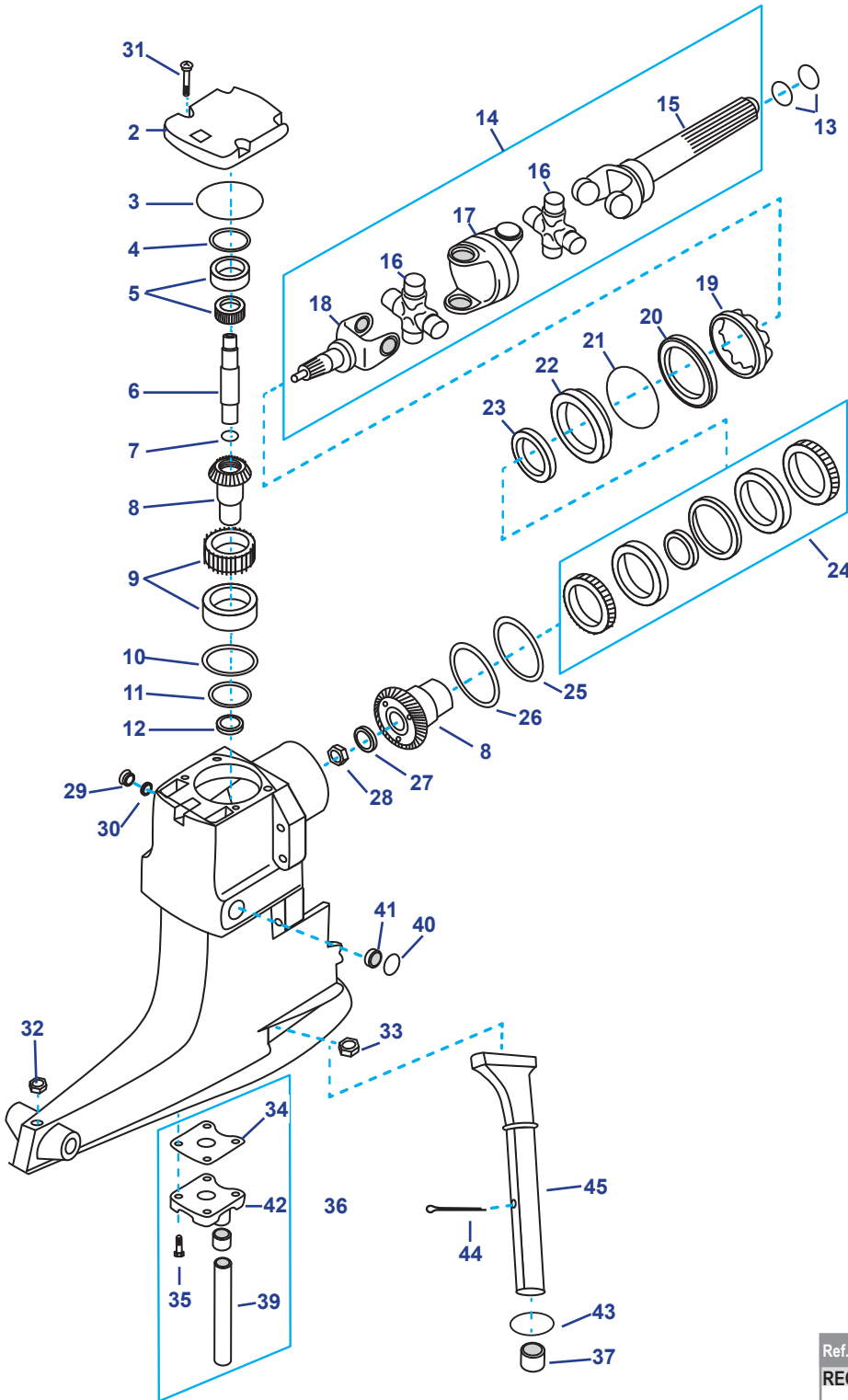

Abrazadera U de acoplamiento (39385A1) en modelos en línea.  
U-joint coupling end yoke (39385A1) used on older in-line models.  
Il giogo terminale di giunzione a giunto U (39385A1) ha utilizzato i modelli on-line in linea.

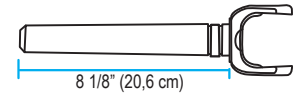

USO DE MODELOS ANTIGUOS DE COLAS EN MODELSO MERCURISER IR-IMR  
USE OF OLDER MODEL STERN DRIVE UNITS ON MERCURISER IR-IMR MODELS  
UTILIZZO DI MODELLI OLDER PIEDE SUI MODELLI IR-IMR MERCURISER

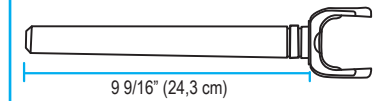

Mercury Marine no recomienda el uso de colas de modelos antiguos en modelos IR-IMR, ya que estas unidades no se acoplarán satisfactoriamente con el ensamblaje del transom. Además, las unidades en serie del modelo anterior, están equipadas con una horquilla de acoplamiento de unión en U (39385A1). Este eje es más corto que el (59830A1) usado en las unidades de impulsión de popa IR-IMR, y por lo tanto no acoplará completamente las estrías del motor. El uso del modelo más antiguo en un modelo de IR-IMR llevará al fallo de spline para acoplar al eje.

Mercury Marine does not recommend the use of older model stern drive units on IR-IMR models, as these units will not mate up satisfactorily with the transom assembly. In addition, the older model in-line stern drive units are equipped with U-joint coupling end yoke (39385A1). This yoke is shorter than yoke (59830A1) used on the IR-IMR stern drive units, and therefore will not fully engage the engine coupler splines. Use of an older in-line model stern drive unit on a IR-IMR model will result in a spline failure to coupling an/or yoke.

Mercury Marine non ha raccomandato l'uso di trasmissione a poppa più vecchie su modelli IR-IMR, in quanto queste unità non si addicono in modo soddisfacente con l'assemblaggio del trampolo. In aggiunta, le unità di comando a poppa in linea in versione anteriore sono dotate di giogo terminale di giunzione a U (39385A1). Questo giogo è più corto del giogo (59830A1) usato sulle unità di azionamento a poppa IR-IMR e pertanto non impegna completamente le spline di accoppiatore del motore. L'uso di un'unità anteriore di tipo a poppa modello in linea su un modello IR-IMR provocherà un errore di spline per accoppiare un / o giogo.

Ref.	R.O. OEM
REC27-64818Q4	26-64818Q4 27-64718A1

Kit juntas  
Gasket kit  
Kit guarnizione

Ref.	R.O. OEM
REC26-32511A1	26-32511A1

Kit retenes  
Seal kit d.S. Housing  
Kit riparazione

Ref.	R.O. OEM
REC43-18411A2	43-18411A4

KIT PIÑONES Y COJINETE  
Reforzados 20/22 (Reducción 1.50) Para V8.  
DRIVE SHAFT HOUSING GEAR SET  
Heavy duty 20/22 (ratio 1.50) for V8  
KIT PIGNONI E CUSCINETTI RINFORZATI  
20/22 Denti (Riduzione 1.50) Per V8.

Nº	Ref.	R.O. OEM	Descripción	Description	Descrizione
2	REC94998A4	94998A4	TAPA CON COJINETE	COVER ASSEMBLY	COPERCHIO CON CUSCINETTO
3	REC25-32546	25-32546	ARO TÓRICO	O-RING	O-RING
4	REC15-45691A1	15-45691A1	SUPLEMENTO (PARA COJINETE REC31-61100A1)	SHIM (FOR REC31-61100A1)	SPESSORE (PER CUSCINETTO REC31-61100A1)
4	REC15-32563A1	15-32563A1	SUPLEMENTO (PARA COJINETE REC31-35988A12)	SHIM (FOR REC31-35988A12)	SPESSORE (PER CUSCINETTO REC31-35988A12)
5	REC31-61100A1	31-61100A1	COJINETE Ø EXTERIOR 49 mm	BEARING ASSY EXTERNAL Ø 49 mm	CUSCINETTO Ø ESTERNO 49 mm
5	REC31-32575T1	31-32575T1	COJINETE Ø EXTERIOR 45 mm	BEARING ASSY EXTERNAL Ø 45 mm	CUSCINETTO Ø ESTERNO 45 mm
6	REC45-55796	45-55796	EJE PIÑÓN	DRIVE SHAFT	ASSE PIGNONE
7	REC25-55801	25-55801	ARO TÓRICO	O-RING	O-RING
8	RM43-66773A3	43-66773A3	JUEGO PIÑONES (RED. 1.32) (16-20)	GEAR SET (1.32) (16-20)	KIT PIGNONI (RID. 1.32) (16-20)
8	REC43-18411A2	43-18411A2	JUEGO PIÑONES H.D. (RED.1.50) (20-22)	GEAR SET HD (1.50) (20-22)	KIT PIGNONI RINFORZATI (RID.1.50) (20-22)
8	REC43-45814A5	43-45814A5	JUEGO PIÑONES (RED.1.65) (24-24)	GEAR SET (1.65) (24-24)	KIT PIGNONI (RID.1.65) (24-24)
8	REC43-75325A3	43-75325A3	JUEGO PIÑONES H.D. (RED.1.84) (17-19)	GEAR SET HD(1.84)(17-19)	KIT PIGNONI RINFORZATI (RD.1.84) (17-19)
8	REC43-55778A3	43-55778A3	JUEGO PIÑONES (RED.1.98) (20-24)	GEAR SET (1.98) (20-24)	KIT PIGNONI (RID.1.98) (20-24)
9	REC31-32573A1	31-32573A1	RODAMIENTO (RED.1.50) ANTIGUA	ROLLER BEARING (1.50) OLD	CUSCINETTO (RID.1.50) VECCHIO MODELLO
9	REC31-35990A1	31-35990A1	RODAMIENTO (RED.1.65-1.84-1.98)	ROLLER BEARING (1.65-1.84-1.98)	CUSCINETTO (RID.1.65-1.84-1.98)
9	REC31-66818A1	31-66818A1	RODAMIENTO (RED.1.32)	ROLLER BEARING (1.32)	CUSCINETTO (RID.1.32)
10	REC15-36178A02	15-36178A02	SUPLEMENTO	SHIM	SPESSORE
11	REC26-32511	26-32511	RETÉN	OIL SEAL	PARAOLIO
12	REC26-965031	26-965031	RETÉN	OIL SEAL	PARAOLIO
13	REC25-25439	25-25439	ARO TÓRICO	O-RING	O-RING
14	REC814819A2	814819A2	CARDÁN COMPLETO	U-JOINT ASSEMBLY	CARDANO COMPLETO
15	REC59830A7	59830A7	EJE LARGO CARDÁN (9-9/16")	YOKE ASSEMBLY (9-9/16")	ASSE CARDANO (9-9/16")
16	REC3850812	75832T1	CRUCETA CARDÁN	U-JOINT	CROCIERA CARDANO
16	REC75832T	75832T	CRUCETA CARDÁN PARA 4 EN LÍNEA Y V-6	U-JOINT FOR 4 INLINE & V6	CROCIERA CARDANO PER MOTORI 4 IN LINEA E -6
16	REC805536A2	805536A2	CRUCETA AUTOENGRASE SIN MANTENIMIENTO	U-JOINT SELF GREASE	CROCIERA AUTOINGRASSANTE
17	REC393831	393831	RÓTULA CARDÁN	SOCKET	SEDE CARDANO
18	REC46020T02	46020T02	EJE CORTO CARDÁN	YOKE	ASSE CARDANO
19	REC8168112	8168112	TUERCA PORTA RETÉN	RETAINER	DADO, SEDE PARAOLIO
20	REC35983	35983	ARO METÁLICO	RING	O-RING METALLICO
21	REC25-70937	25-70937	ARO TÓRICO	O-RING	O-RING
22	REC66081A2	66081A2	CIERRE CARCASA	CARRIER ASSEMBLY	CHIUSURA CARCASSA
23	REC26-823894	26-823894	RETÉN	OIL SEAL	PARAOLIO
24	REC31-35988A12	31-35988A12	RODAMIENTO EXCEPTO 1.32	ROLLER BEARING (ALL RATIO EXCEPT 1.32)	CUSCINETTO ECCETTO 1.32
25	REC15-35980A1	15-35980A1	SUPLEMENTO	SHIM	SPESSORE
26	REC15-71013	15-71013	SUPLEMENTO	SHIM	SPESSORE
27	REC12-45810	12-45810	ARANDELA TOPE	WASHER	RONDELLA
28	REC11-22339	11-22339	TUERCA	NUT	DADO
29	REC10-79953Q04	10-79953Q04	TAPÓN ACEITE	SCREW	TAPPO OLIO
30	REC12-191833	12-191833	JUNTA TAPÓN	WASHER	GUARNIZIONE TAPPO
31	REC10-98794	10-98794	TORNILLOS TAPA 3/8-16	SCREW 3/8-16	VITE 3/8-16
32	REC19-47579	19-47579	TAPA PLÁSTICO	PLUG	COPERCHIO IN PLASTICA
33	REC11-34933	11-859116	TUERCA	NUT	DADO
34	REC27-558101	27-55810 1	JUNTA	GASKET	GUARNIZIONE
35	REC10-28668	10-28668	TORNILLO	SCREW	VITE
36	REC42724A3	42724A3	JUEGO REFRIGERACIÓN	WATER POCKET COVER KIT	KIT RIPARAZIONE
37	REC23-32632	23-32632	CASQUILLO	BUSHING	BOCCOLA
39	REC32-54236	32-54236	TUBO DE GOMA	WATER TUBE	TUBO IN GOMMA
40	REC19-42682	19-42682	TAPÓN	WELCH PLUG (1-174 O.D.)	TAPPO
41	REC22-428611	22-428611	TAPA TAPÓN	PIPE PLUG	COPERCHIO TAPPO
42	REC26-36557	26-36557	CASQUILLO GOMA	GROMMET	BOCCOLA IN GOMMA
43	REC12-32666	12-32666	ARANDELA	WASHER	RONDELLA
44	REC18-32665	18-32665	PASADOR	PIN	FERMO
45	REC621041	621041	EJE SELECTOR	SELECTOR SHAFT	ASSE SELETTORE

**MC1 / R**

Ref. R.O. OEM  
**REC12110**

Kit reparacion / Seal kit / Kit riparazione  
(1970-83)

Ref. R.O. OEM  
**REC47-89984Q5**

Kit reparacion / Seal kit / Kit riparazione

Ref. R.O. OEM  
**REC46-64141A11**

Kit reparacion / Seal kit / Kit riparazione  
MC1 (-1968)

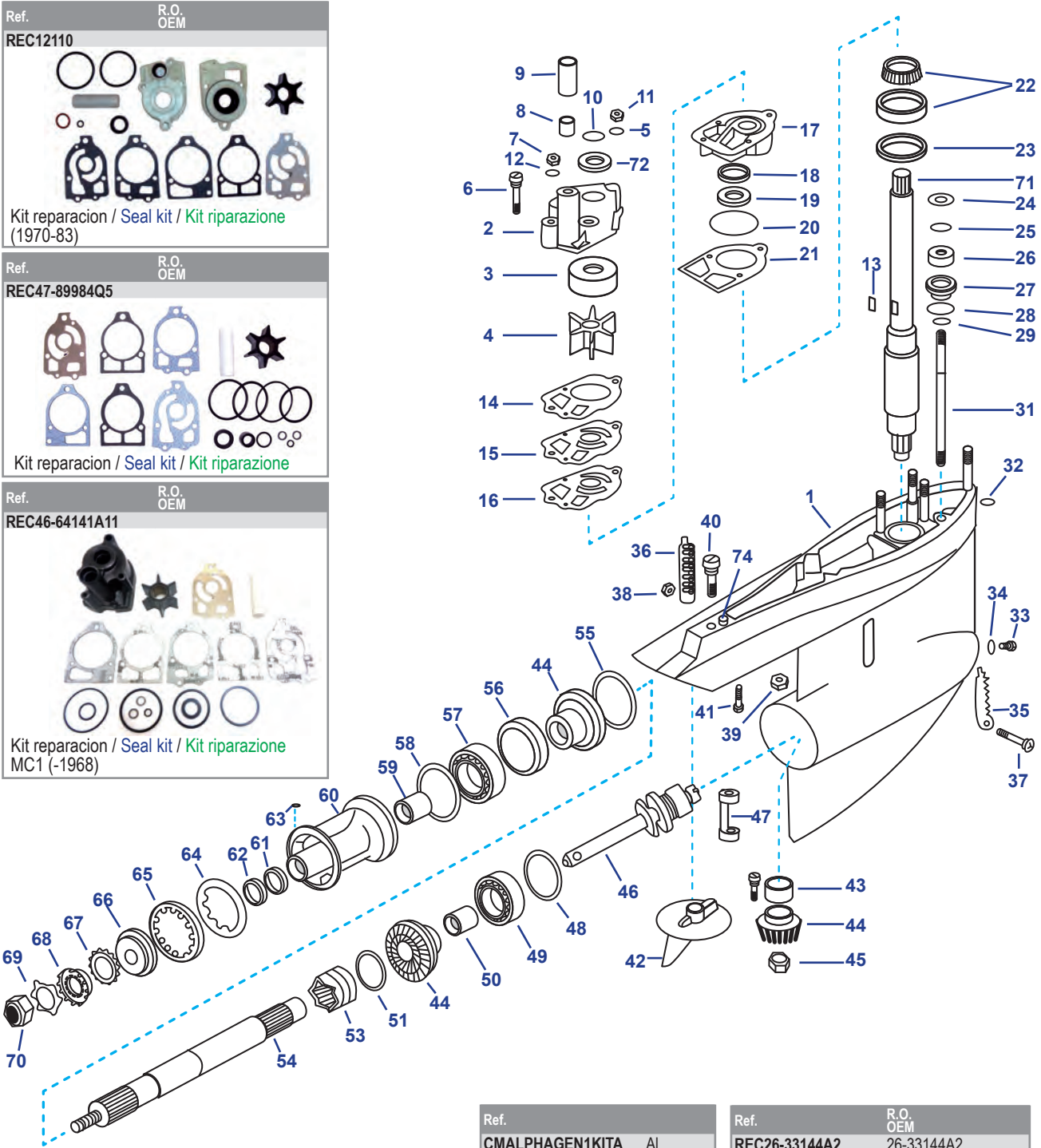

Ref. R.O. OEM  
**REC11-52707Q1** 11-52707Q1

Kit cierre hélice  
Propeller nut kit  
Kit ciusura elicha

Ref. R.O. OEM  
**CMALPHAGEN1KITA** AI  
**CMALPHAGEN1KITM** MG  
**TENKITALPHAONE/1** ZN

Kit ánodos  
Anode kit  
Kit anodi

Ref. R.O. OEM  
**REC26-33144A2** 26-33144A2

Kit reparacion  
Seal kit  
Kit riparazione

Nº	Ref.	R.O. OEM	Descripción	Description	Descrizione
1	REC1623-5356A4	1623-5356A4	CARCASA	HOUSING	CARCASSA
2	REC46-96148T1	46-96148T1	CUERPO BOMBA AGUA	HOUSING WATER PUMP	CORPO POMPA ACQUA
3	REC48752T	48752T	CASQUILLO BOMBA	INSERT	BOCCOLA
4	REC47-89984T4	47-89984T4	IMPULSOR	IMPELLER	GIRANTE
5	REC92995-08600	12-36001	ARANDELA	WASHER	RONDELLA

Nº	Ref.	R.O. OEM	Descripción	Description	Descrizione
6	REC10-30720	10-30720	TORNILLO	SCREW	VITE
7	REC11-8267089	11-8267089	TUERCA	NUT	DADO
8	REC26-38970	26-38970	RETÉN	OIL SEAL	TENUTA
9	REC23-29804T	23-29804T	TUBO GUÍA	WATER PIPE	TUBO
10	REC25-30613	25-30613	ANILLO GOMA	RUBBER RING	TENUTA
11	REC11-13436	11-13436	TUERCA	NUT	DADO
12	REC12-29245	12-29245	ARANDELA	WASHER	RONDELLA
13	REC8M0032834	28-8M0032834	CHAVETA	KEY	CHIAVETTA
14	REC27-858524	27-858524	JUNTA TAPA BOMBA	COVER GASKET	GUARNIZIONE COPERCHIO
15	REC324351	324351	TAPA BOMBA AGUA	COVER	COPERCHIO POMPA ACQUA
16	REC27-856081	27-856081	JUNTA BOMBA	PUMP GASKET	GUARNIZIONE POMPA
17		46-57234A1	BASE BOMBA	PUMP BASE	BASE POMPA
18	REC26-16977	26-16977	RETÉN	SEAL	TENUTA
19	REC26-89238	26-89238	RETÉN	SEAL	TENUTA
20	REC25-33145	25-33145	ARO TÓRICO	O-RING	O-RING
21	REC27-856704	27-856704	JUNTA	GASKET	GUARNIZIONE
22	REC31-53079A1	31-53079A1	RODAMIENTO	BEARING	CUSCINETTO
23	REC15-57007A1	15-57007A1	SUPLEMENTO	SPACER	DISTANZIALE
24	REC8M0042641	12-8M0042641	ARANDELA	WASHER	RONDELLA
25	REC12-31266	12-31266	ARANDELA	WASHER	RONDELLA
26	REC26-8164641	26-8164641	RETÉN	SEAL	TENUTA
27	REC23-30617A2	23-30617A2	ACOPLE EJE	ATTACHING SHAFT	FISSAGGIO ASSE
28	REC25-25439	25-25439	ARO TÓRICO	O-RING	TENUTA
29	REC12-27880	12-27880	ARO	O-RING	O-RING
31	REC774811	774811	EJE TRANSMISIÓN	SHIFT	ASSE
32	REC26-455771	26-455771	RETÉN	SEAL	TENUTA
33	REC22-67892A05	8M0058389	TORNILLO CON RETÉN	SCREW WITH SEAL	VITE CON TENUTA
34	REC12-191833	12-191833	JUNTA	GASKET	GUARNIZIONE
35	REC934231	934231	TAPA REFRIGERACIÓN	CAP	COPERCHIO
36	REC934241	934241	TAPA REFRIGERACIÓN	CAP	COPERCHIO
37	REC10-76156	10-76156	TORNILLO	SCREW	VITE
38	REC11-859124	11-859124	TUERCA	NUT	DADO
39	REC11-34933	11-859116	TUERCA	NUT	DADO
40	REC10-32470	10-32470	TORNILLO	SCREW	VITE
41	REC10-30206	10-30206	TORNILLO	SCREW	VITE
42	CM31640	31640Q4	ANODO TIMÓN ZINC	ZINC ANODE	ANODO ZINCO
42	CM31640A	31640Q4	ANODO TIMÓN ALUM.	ALLUMINIUM ANODE	ANODO ALLUMINIO
43	REC31-92366A1	31-92366A1	RODAMIENTO	BEARING	CUSCINETTO
44		43-96084A4	KIT PIÑONES	PINION KIT	KIT PIGNONE
45	REC11-35921	11-35921	TUERCA PIÑÓN	PINION NUT	PIGNONE DADO
46	REC818349T1	818349T1	EJE DESPLAZABLE	SLIDE SHIFT	PASSANTE
47	REC76865	76865	HORQUILLA CAMBIO	CLIP	CLIP
48	REC15-47397A1	15-47397A1	ARANDELA	WASHER	RONDELLA
49	REC31-35928T1	31-35928T1	RODAMIENTO	BEARING	CUSCINETTO
50	REC31-30895T	31-30895T	RODAMIENTO	BEARING	CUSCINETTO
51	REC31-30895T	24-30893	MUELLE	SPRING	MOLLA
52	REC17-8M0084681	8M0020941	PASADOR	PIN	SPINOTTO
53	REC52-853594T	52-853594T	PIÑÓN CAMBIO	SHAFT PINION	PIGNONE CAMBIO
54	REC44-824110	44-824110	EJE HÉLICE	SHAFT PROPELLER	ASSE ELICA
56	REC35915	35915	SEPARADOR PIÑÓN	SPACER PINION	DISTANZIALE PIGNONE
57	REC30-88957T	30-88957T	RODAMIENTO	BEARING	CUSCINETTO
58	REC25-31534	25-31534	ARO TÓRICO	O-RING	ANELLO
59	REC387247	31-30956T	RODAMIENTO	BEARING	CUSCINETTO
60	REC818763A10	818763A10	COJINETE COLA	SHAFT BEARING	CUSCINETTO PIEDE
61	REC26-76868	26-76868	RETÉN INTERIOR	INNER SEAL	TENUTA INTERNO
62	REC26-12224	26-12224	RETÉN EXTERIOR	OUTLER SEAL	TENUTA ESTERNO
63	REC28-30281	28-30281	CIERRE	CAP	CHIUSURA
64	REC14-79447	14-79447	ARANDELA CIERRE	WASHER CAP	RONDELLA CHIUSURA
65	REC8M2011027	8M2011027	TUERCA	NUT	DADO
66	REC12-835467Q01	12-835467Q01	SEPARADOR	SPACER	DISTANZIALE
67	REC13-423511	13-42351-1	ARANDELA CIERRE	WASHER CAP	RONDELLA CHIUSURA
68	REC12-31211Q03	12-31211Q03	CASQUILLO	INSERT, CARTDRIGE	GHIERA
69	REC90508-ZW1-003	816629Q	ARANDELA TUERCA	WASHER NUT	RONDELLA DADO
70	REC90301-ZW1-003	11-827614	TUERCA EJE	NUT SHAFT	DADO ASSE
71	REC45-41939F1	45-41939F1	EJE TRANSMISIÓN	TRANSMISSION SHAFT	ASSE TRASMISSIONE
72	REC25-30271	25-30271	ARANDELA	WASHER	RONDELLA
74	REC331880	17-35973	PASADOR	PIN	SPINOTTO

**MR / ALPHA ONE**

Ref.	R.O. OEM	
CM806105	806105Q1	Zn
CM806105A	806105Q1	Al



Ánodo eje hélice  
Prop shaft anode  
Anodo asse elica

Ref.	R.O. OEM
REC12120	



Kit reparación / Seal kit / Kit riparazione

Ref.	R.O. OEM
REC47-89984Q5	



Kit reparación / Seal kit / Kit riparazione

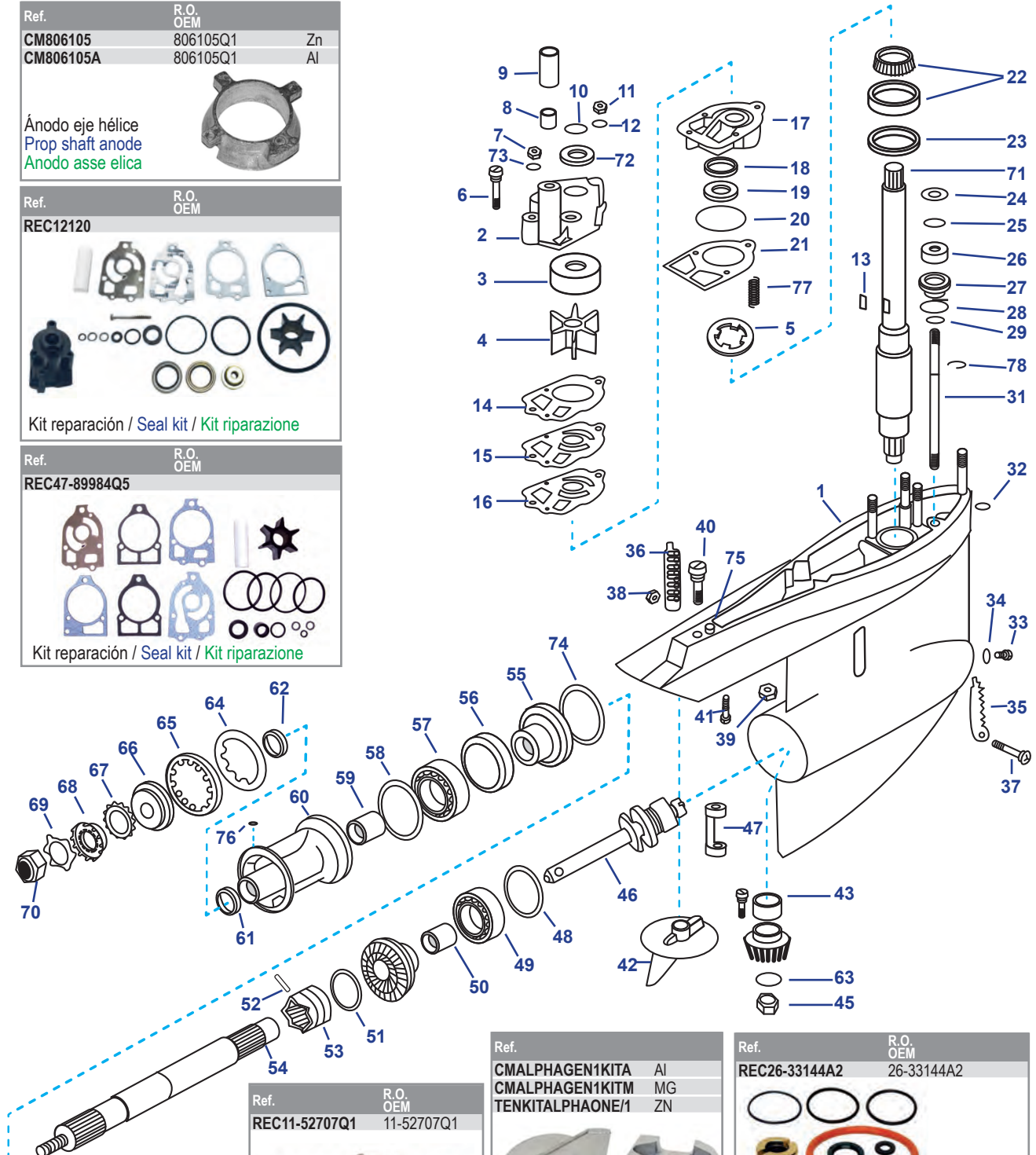

Ref.	R.O. OEM
REC11-52707Q1	11-52707Q1



Kit cierre hélice  
Propeller nut kit  
Kit chiusura elica

Ref.	R.O. OEM
CMALPHAGEN1KITA	Al
CMALPHAGEN1KITM	MG
TENKITALPHAONE/1	ZN



Kit ánodos  
Anode kit  
Kit anodi

Ref.	R.O. OEM
REC26-33144A2	26-33144A2



Kit reparación  
Seal kit  
Kit riparazione

Nº	Ref.	R.O. OEM	Descripción	Description	Descrizione
1	REC1623-8951A37	1623-8951A37	CARCASA COLA	HOUSING	CARASSA
2	REC46-96148T1	46-96148T1	CUERPO BOMBA AGUA	HOUSING WATER PUMP	CORPO POMPA ACQUA
3	REC48752T	48752T	CASQUILLO BOMBA	INSERT	BOCCOLA
4	REC47-89984T4	47-89984T4	IMPULSOR	IMPELLER	GIRANTE
5	REC8245191	8245191	ARANDELA	WASHER	RONDELLA
6	REC10-96411	10-96411	TORNILLO	SCREW	VITE
7	REC11-8267089	11-8267089	TUERCA	NUT	DADO
8	REC26-38970	26-38970	RETÉN	SEAL	TENUTA

Nº	Ref.	R.O. OEM	Descripción	Description	Descrizione
9	REC23-29804T	23-29804T	TUBO GUÍA	WATER PIPE	TUBO
10	REC25-30613	25-30613	ARO TÓRICO	O-RING	O-RING
11	REC11-13436	11-13436	TUERCA	NUT	DADO
12	REC92995-08600	12-36001	ARANDELA	WASHER	RONDELLA
13	REC8M0032834	8M0032834	CHAVETA	KEY	CHIAVETTA
14	REC27-858524	27-858524	JUNTA TAPA BOMBA	COVER GASKET	GUARNIZIONE COPERCHIO
15	REC324351	324351	TAPA BOMBA AGUA	COVER	COPERCHIO
16	REC27-856081	27-856081	JUNTA BOMBA	PUMP GASKET	GUARNIZIONE POMPA
17	REC46-44292Q03	46-44292Q03	BASE BOMBA	PUMP BASE	BASE POMPA
18	REC26-16977	26-16977	RETÉN	SEAL	TENUTA
19	REC26-89238	26-89238	RETÉN	SEAL	TENUTA
20	REC25-90011	25-90011	ARO TÓRICO (Ø 2.188")	O-RING (Ø 2.188")	O-RING (Ø 2.188")
20	REC25-38099	25-38099	ARO TÓRICO (Ø 2.125")	O-RING (Ø 2.125")	O-RING (Ø 2.125")
21	REC27-426311	27-42631-1	JUNTA	GASKET	GUARNIZIONE
22	REC31-36387A1	31-36387A1	RODAMIENTO	BEARING	CUSCINETTO
23	REC15-42637A1	15-42637A1	GRUESO	SHIM	SPESORE
24	REC8M0042641	8M0042641	ARANDELA	WASHER	RONDELLA
25	REC12-31266	12-31266	ARANDELA	WASHER	RONDELLA
26	REC26-8164641	26-8164641	RETÉN	SEAL	TENUTA
27	REC23-30617A2	23-30617A2	ACOPLE EJE	ATTACHING SHAFT	FISSAGGIO ASSE
28	REC25-25439	25-25439	ARO TÓRICO	O-RING	O-RING
29	REC12-27880	12-27880	ARO	O-RING	O-RING
31	REC774811	774811	EJE TRANSMISIÓN	TRANSMITION SHAFT	ASSE TRASMISSIONE
32	REC26-455771	26-45577 1	RETÉN	SEAL	TENUTA
33	REC22-67892A05	8M0058389	TORNILLO CON RETÉN	SCREW WITH SEAL	VITE CON TENUTA
34	REC12-191833	12-191833	JUNTA	GASKET	GUARNIZIONE
35	REC934231	934231	TAPA REFRIGERACIÓN	CAP	COPERCHIO
36	REC934241	934241	TAPA REFRIGERACIÓN	CAP	COPERCHIO
37	REC10-76156	10-76156	TORNILLO	SCREW	VITE
38	REC11-859124	11-859124	TUERCA	NUT	DADO
39	REC11-34933	11-859116	TUERCA	NUT	DADO
40	REC10-32470	10-32470	TORNILLO	SCREW	VITE
41	REC10-30206	10-30206	TORNILLO	SCREW	VITE
42	CM31640	31640Q4	ANODO TIMÓN ZINC	ZINC SHAFT ANODE	ANODO ZINCO TIMONE
42	CM31640A	31640Q4	ANODO TIMÓN ALUMINIO	ALLUMINIUM SHAFT ANODE	ANODO ALLUMINIO TIMONE
43	REC387817	31-42647A1	RODAMIENTO	BEARING	CUSCINETTO
45	REC11-35921	11-35921	TUERCA PIÑÓN	PINION NUT	DADO PIGNONE
46	REC818349T1	818349T1	EJE DESPLAZABLE	SLIDE SHIFT	PASSANTE
47	REC76865	76865	HORQUILLA CAMBIO	CLIP	CLIP
48	REC15-47397A1	15-47397A1	ARANDELA	WASHER	RONDELLA
49	REC31-35928T1	31-35928T1	RODAMIENTO Ø 47,6 mm	BEARING Ø 47.6 mm	CUSCINETTO Ø 47.6 mm
49	REC31-828437A2	31-828437A2	RODAMIENTO Ø 44,4 mm	BEARING Ø 44.4 mm	CUSCINETTO Ø 44.4 mm
50	REC31-30895T	31-30895T	RODAMIENTO	BEARING	CUSCINETTO
51	REC24-30893	24-30893	MUELLE	SPRING	MOLLA
52	REC17-8M0084681	8M0020941	PASADOR	PIN	SPINOTTO
53	REC52-853594T	52-853594T	PIÑÓN CAMBIO	SHAFT PINION	PIGNONE CAMBIO
54	REC44-824110	44-824110	EJE HÉLICE	SHAFT PROPELLER	ASSE ELICA
54	REC44-8146061	44-8146061	EJE HÉLICE CONTRAROTACIÓN	SHAFT PROPELLER COUNTER ROTATION	ASSE ELICA CONTROROTANTE
55	REC43-828073A1	43-828073A1	PIÑÓN MARCHA ATRÁS	PINION REVERSE	PIGNONE RETROMARCIA
56	REC681001	681001	SEPARADOR PIÑÓN	PINION SPACER	DISTANZIALE PIGNONE
57	REC30-88957T	30-88957T	RODAMIENTO	BEARING	CUSCINETTO
58	REC25-31534	25-31534	ARO TÓRICO	O-RING	ANELL
59	REC387247	31-30956T	RODAMIENTO	BEARING	CUSCINETTO
60	REC818763A10	818763A10	COJINETE COLA	SHAFT BEARING	CUSCINETTO PIEDE
60	REC14587A7	14587A5	COJINETE COLA CONTRAROTACIÓN	SHAFT BEARING COUNTER ROTATION	CUSCINETTO PIEDE CONTROROTANTE
61	REC26-76868	26-76868	RETÉN INTERIOR	INNER SEAL	TENUTA INTERNO
62	REC26-12224	26-12224	RETÉN EXTERIOR	OUTLER SEAL	TENUTA ESTERNO
63	REC350038	12-92721	CIERRE	CAP	CHIUSURA
64	REC14-18323	14-18323	ARANDELA CIERRE	WASHER	RONDELLA CHIUSURA
65	REC8M2011027	8M2011027	TUERCA	NUT	DADO
66	REC12-835467Q01	12-835467Q01	SEPARADOR	SPACER	DISTANZIALE
67	REC13-423511	13-423511	ARANDELA CIERRE	WASHER	RONDELLA CHIUSURA
68	REC12-31211Q03	12-31211Q03	CASQUILLO	INSERT	BOCCOLA
69	REC90508-ZW1-003	14-816629Q	ARANDELA TUERCA	WASHER NUT	RONDELLA DADO
70	REC90301-ZW1-003	11-827614	TUERCA EJE	SHAFT NUT	DADO ASSE
71	REC45-42634	45-42634	EJE TRANSMISIÓN	TRANSMITION SHAFT	ASSE TRASMISSIONE
72	REC25-30271	25-30271	RETÉN	SEAL	TENUTA
73	REC12-29245	12-29245	ARANDELA	WASHER	RONDELLA
74	REC23-824108	23-824108	ESPACIADOR	SPACER	DISTANZIALE
75	REC331880	17-35973	PASADOR	PIN	SPINOTTO
76	REC28-30281	28-30281	CHAVETA	KEY	CHIAVETTA
77	REC24-34576	24-34576	MUELLE	SPRING	MOLLA
78	REC53-29641	53-29641	CLIP	LOCKER	CLIP

ALPHA ONE GEN II  
OD469859-OK999999 (1991-97)

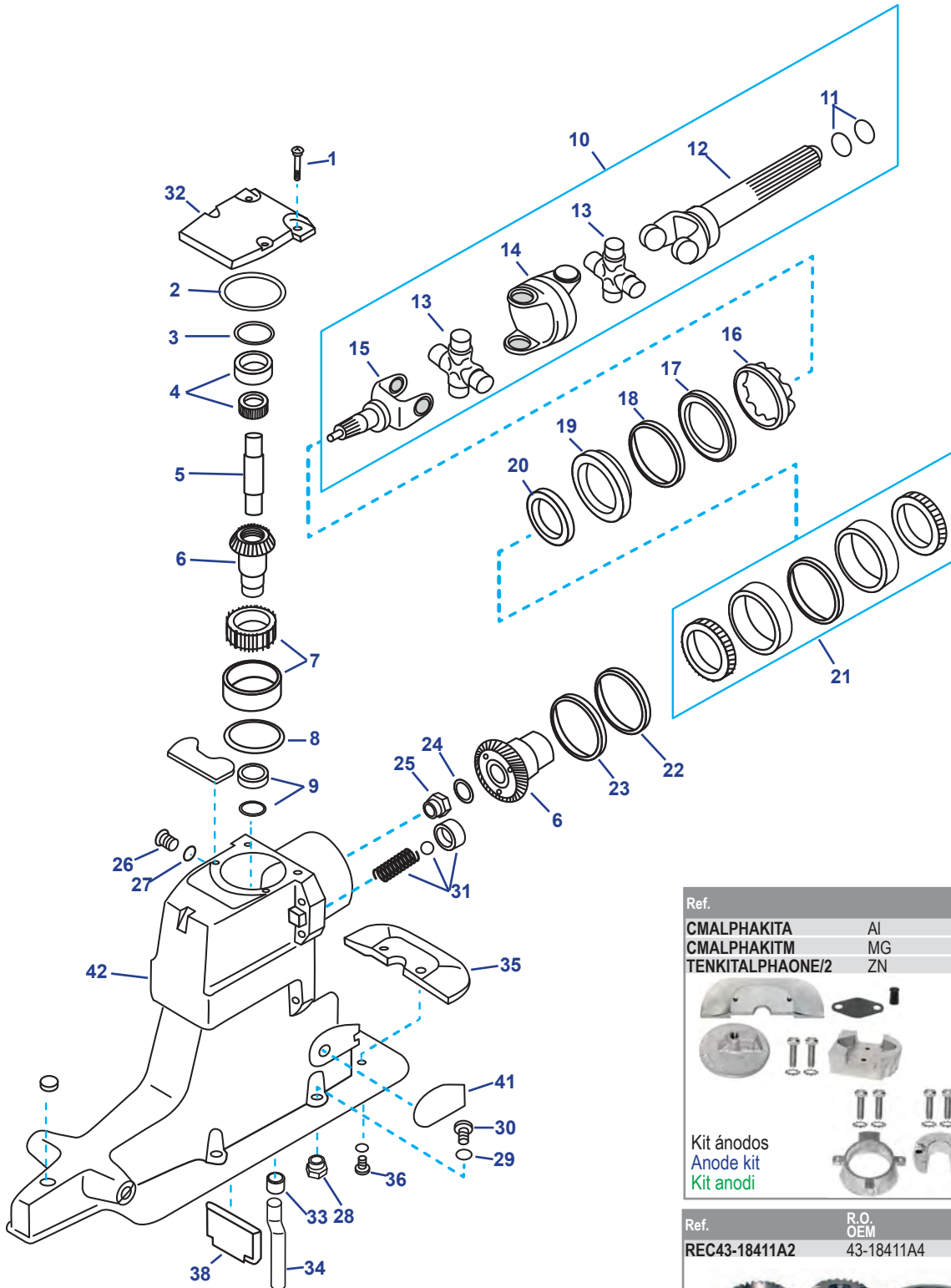

Ref.	
CMALPHAKITA	AI
CMALPHAKITM	MG
TENKITALPHAONE/2	ZN

Kit ánodos  
Anode kit  
Kit anodi

Ref.	R.O. OEM
REC43-18411A2	43-18411A4

KIT PIÑONES Y COJINETE  
Reforzados 20/22 (Reducción 1.50) Para V8.  
DRIVE SHAFT HOUSING GEAR SET  
Heavy duty 20/22 (ratio 1.50) for V8  
KIT PIGNONI E CUSCINETTI RINFORZATI  
20/22 Denti (Riduzione 1.50) Per V8.

Ref.	R.O. OEM
REC26-88397A1	26-88397A1

Kit reparación  
Gearcase seal kit  
Kit riparazione

Ref.	R.O. OEM
REC27-94996Q2	27-94996Q2

Kit juntas  
Gearcase seal kit  
Kit riparazione

Nº	Ref.	R.O. OEM	Descripción	Description	Descrizione
1	REC10-98794	10-98794	TORNILLO	SCREW	VITE
2	REC25-32546	25-32546	ARO TÓRICO	O-RING	O-RING
3	REC15-45691A1	15-45691A1	GRUESO (PARA RODAMIENTO 21510)	SHIM (FOR BEARING 21510)	SPESSORE (PER CUSCINETTO 21510)
3	REC15-32563A1	15-32563A1	GRUESO (PARA RODAMIENTO 21511)	SHIM (FOR BEARING 21511)	SPESSORE (PER CUSCINETTO 21511)
4	REC31-61100A1	31-61100A1 (1991-95)	RODAMIENTO Ø EXTERIOR 49 mm	BEARING Ø EXTERNAL 49 mm	CUSCINETTO Ø ESTERNO 49 mm
4	REC31-32575T1	31-32575T1 (-1996)	RODAMIENTO Ø EXTERIOR 45 mm	BEARING Ø EXTERNAL 45 mm	CUSCINETTO Ø ESTERNO 45 mm
5	REC45-557961	45-55796-1	EJE PIÑÓN	PINION SHAFT	ASSE PIGNONE
6	REC43-18411A2	43-18411A2	KIT PIÑONES (REDUCCIÓN 1.50/1.47) (20-22) 1991-97	PINION KIT (RATIO 1.50/1.47) (20-22) 1991-97	KIT PIGNONE (RIDUZIONE 1.50/1.47) (20-22) 1991-97
6	REC43-45814A5	43-45814A5	KIT PIÑONES (REDUCCIÓN 1.65/1.62) (24-24) 1991-97	PINION KIT (RATIO 1.65/1.62) (24-24) 1991-97	KIT PIGNONE (RIDUZIONE 1.65/1.62) (24-24) 1991-97
6	REC43-75325A3	43-75325A3	KIT PIÑONES (REDUCCIÓN 1.84/1.81) (17-19) 1991-97	PINION KIT (RATIO 1.84/1.81) (17-19) 1991-97	KIT PIGNONE (RIDUZIONE 1.84/1.81) (17-19) 1991-97
6	REC43-55778A3	43-55778A3	KIT PIÑONES (REDUCCIÓN 1.98/1.94) (20-24) 1991-97	PINION KIT (RATIO 1.98/1.94) (20-24) 1991-97	KIT PIGNONE (RIDUZIONE 1.98/1.94) (20-24) 1991-97
7	REC31-35990A1	31-35990A1	RODAMIENTO (REDUCCIÓN 1.65, 1.84, 1.98, 2.40)	BEARING (RATIO 1.65, 1.84, 1.98, 2.40)	CUSCINETTO (RIDUZIONE 1.65, 1.84, 1.98, 2.40)
7	REC31-32573A1	31-32573A1	RODAMIENTO (REDUCCIÓN 1.47)	BEARING (RATIO 1.47)	CUSCINETTO (RIDUZIONE 1.47)
8	REC15-36178A02	15-36178A02	SUPLEMENTO	SPACER	DISTANZIALE
9	REC26-66302	26-66302	RETÉN	SEAL	TENUTA
10	REC814819A2	814819A2	KIT TRANSMISIÓN (1991-97)	TRANSMISSION KIT (1991-97)	KIT TRASMISSIONE (1991-97)
10	REC864281A2	864281A2	KIT TRANSMISIÓN (1998+)	TRANSMISSION KIT (1998+)	KIT TRASMISSIONE (1998+)
11	REC25-25439	25-25439	ARO TORICO	O-RING	O-RING
11	REC25-35027	25-35027	ARO TÓRICO	O-RING	O-RING
12	REC59830A7	59830A7	UNIÓN COLA - MOTOR	UNION DRIVE SHAFT - ENGINE	ASSE CARDANO PIEDE MOTORE
13	REC3850812	75832T1	CRUCETA (1991-95)	JOINT (1991-95)	CROCETTA (1991-95)
13	REC805536A2	805536A2	CRUCETA (1996+)	JOINT (1996+)	CROCETTA (1996+)
13	REC75832T	75832T	CRUCETA PARA 4 EN LÍNEA Y V6 (-1995)	JOINT 4 INLINE & V6 (-1995)	CROCETTA 4 IN LINEA E V6 (-1995)
14	REC393831	393831	CARDAN	CARDAN	CARDAN
15	REC46020T02	46020T02	UNIÓN COLA-CARDAN (1991-97)	UNION DRIVE SHAFT - CARDAN (1991-97)	ASSE CARDANO PIEDE (1991-97)
16	REC8168112	8168112	TUERCA PORTA RETÉN	SEAL'S NUT	DADO PORTA TENUTA
17	REC35983	35983	ARO	O-RING	O-RING
18	REC25-70937	25-70937	ARO TÓRICO	O-RING	O-RING
19	REC66081A2	66081A2	CUERPO RETÉN CARDAN	HOUSING CARDAN SEAL	PARAOILIO CARDANO
20	REC26-823894	26-823894	RETÉN	SEAL	TENUTA
21	REC31-35988A12	31-35988A12	RODAMIENTO (1991-97)	BEARING (1991-97)	CUSCINETTO (1991-97)
22	REC15-35980A1	15-35980A1	SUPLEMENTO	SPACER	DISTANZIALE
23	REC15-71013	15-71013	ESPACIADOR	SPACER	DISTANZIALE
24	REC12-45810	12-45810	ARANDELA	WASHER	RONDELLA
25	REC11-22339	11-22339	TUERCA	NUT	DADO
26	REC10-79953Q04	10-79953Q04	TORNILLO COLA	SCREW	VITE
27	REC12-191833	12-191833	JUNTA	GASKET	GUARNIZIONE
28	REC11-859135	859135	TUERCA	NUT	DADO
29	REC12-45176	12-35935	ARANDELA	WASHER	RONDELLA
30	REC10-816601	10-816601	TORNILLO	SCREW	VITE
31	REC24-17997A1	24-17997A1	KIT MUELLE BOLA	SPRING BALL KIT	KIT MOLLA
32	REC828692A1	828692A1	TAPA SUPERIOR CON NIVEL DE ACEITE	UPPER CAP WITH OIL LEVEL	COPERCHIO SUPERIORE CON LIVELLO OLIO
33	REC26-88397	26-88397	TUBO GOMA	RUBBER TUBE	TUBO GOMMA
34	REC32-860220	32-860220	TUBO SUBIDA AGUA	WATER UP TUBE	TUBO ASPIRAZIONE ACQUA
35	CM821629	821629Q1	ANODO ZINC	ZINC ANODE	ANODO ZINCO
35	CM821629A	821629Q1	ANODO ALUMINIO	ALLUMINIUM ANODE	ANODO ALLUMINIO
36	REC10-28668	10-28668	TORNILLO	SCREW	VITE
38	RM815932	815932	SEPARADOR ESCAPE	SPACER EXHAUST	SPAZIATORE SCARICO
41	REC8M2015937	8M2015937	TAPA BABOR	PORT CAP	COPERCHIO SINISTRO
41	REC8M2015938	8M2015938	TAPA ESTRIBOR	STD CAP	COPERCHIO DESTRO
42	REC1547-815930A7	1547-815930A7	CARCASA	HOUSING	CARASSA



ALPHA ONE GEN II  
OL100040+ (1998+)

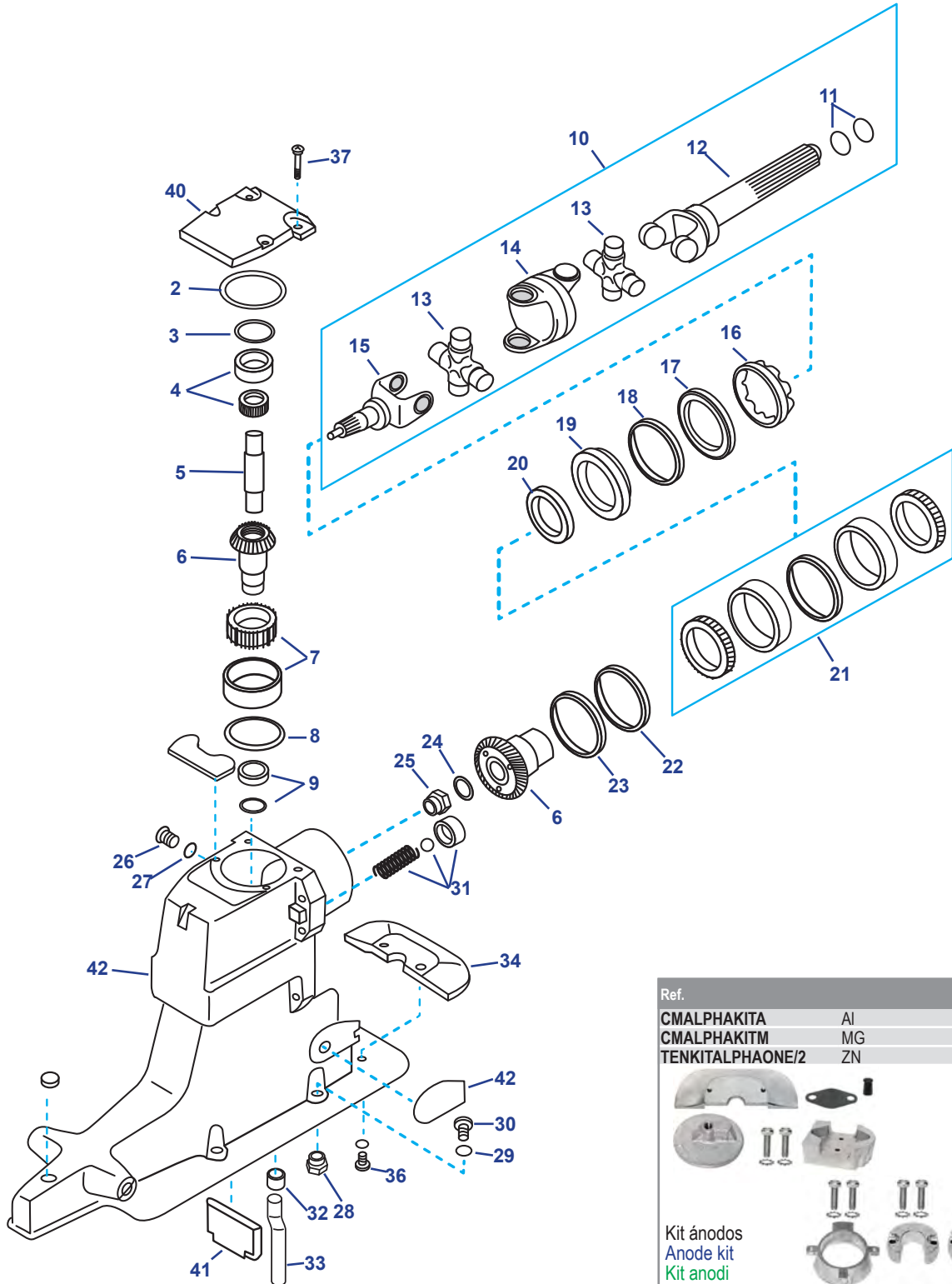

Ref.		
CMALPHAKITA	AI	
CMALPHAKITM	MG	
TENKITALPHAONE/2	ZN	

Kit ánodos  
Anode kit  
Kit anodi

Ref.	R.O. OEM
REC26-88397A1	26-88397A1

Kit reparación  
Gearcase seal kit  
Kit riparazione

Ref.	R.O. OEM
REC27-94996Q2	27-94996Q2

Kit juntas  
Gearcase seal kit  
Kit riparazione

Ref.	R.O. OEM
REC864281A2	864281A2

Kit transmission GNK (negro)  
Yoke assembly GNK (black)  
Giunto cardanico GNK (nero)

Nº	Ref.	R.O. OEM	Descripción	Description	Descrizione
2	REC25-32546	25-32546	ARO	O-RING	ANELLO
3	REC15-32563A1	15-32563A1	SUPLEMENTO (COJINETE 21511)	SHIM (FOR 21511 BEARING)	ESPESORE (CUSCINETTO 21511)
4	REC31-32575T1	31-32575T1	COJINETE (O.D. 1-25/32)	BEARING ASSEMBLY (O.D. 1-25/32)	CUSCINETTO (O.D. 1-25/32)
5	REC45-557961	45-557961	EJE	DRIVE SHAFT	ASSE
6	REC43-853641A2	43-853641A2	KIT PIÑONES (REDUCCIÓN 1.47) (20-22)	GEAR SET (1.47 RATIO) (20-22)	KIT PIGNONE (RIDUZIONE 1.47) (20-22)
6	REC43-853640A2	43-853640A2	KIT PIÑONES (REDUCCIÓN 2.00/1.62) (24-24)	GEAR SET (2.00/1.62 RATIO) (24-24)	KIT PIGNONE (RIDUZIONE 2.00/1.62) (24-24)
6	REC43-853643A2	43-853643A2	KIT PIÑONES (REDUCCIÓN 1.81) (17-19)	GEAR SET (1.81 RATIO) (17-19)	KIT PIGNONE (RIDUZIONE 1.81) (17-19)
6	REC43-853642A2	43-853642A2	KIT PIÑONES (REDUCCIÓN 2.40/1.94) (20-24)	GEAR SET (2.40/1.94 RATIO) (20-24)	KIT PIGNONE (RIDUZIONE 2.40/1.94) (20-24)
7	REC31-35990A1	31-35990A1	COJINETE (REDUCCIÓN 1.62, 1.81, 1.94, 2.00, 2.40)	ROLLER BEARING (1.62, 1.81, 1.94, 2.00, 2.40 RATIO)	CUSCINETTO (RIDUZIONE 1.62, 1.81, 1.94, 2.00, 2.40)
7	REC31-32573A1	31-32573A1	COJINETE (REDUCCIÓN 1.47)	ROLLER BEARING (1.47 RATIO)	CUSCINETTO (RIDUZIONE 1.47)
8	REC15-36178A02	15-36178A02	SUPLEMENTO	SHIM	SPESSORE
9	REC26-66302	26-66302	RETÉN (-OM400411)	OIL SEAL (-OM400411)	PARAOLIO (-OM400411)
9	REC26-864319	26-864319	RETÉN (OM400412+)	OIL SEAL (OM400412+)	PARAOLIO (OM400412+)
10	REC814819A7	814819A7	KIT TRANSMISIÓN (GRIS)	U-JOINT ASSEMBLY (GREY)	KIT TRASMISSIONE (GRIGIO)
10	REC864281A2	864281A2	KIT TRANSMISIÓN GKN (NEGRO) (OL100009+)	U-JOINT ASSEMBLY GKN (BLACK) (OL100009+)	KIT TRASMISSIONE GKN (NERO) (OL100009+)
11	REC25-25439	25-25439	ARO	O-RING	ANELLO
11	REC25-35027	25-35027	ARO	O-RING	ANELLO
12	REC59830A7	59830A7	UNIÓN COLA (-OM400411)	YOKE ASSY. (-OM400411)	UNIONE PIEDE (-OM400411)
12	REC864281A1	865491A01 864281A01	UNIÓN COLA (OM400412+)	YOKE ASSY. (OM400412+) (GKN)	UNIONE PIEDE (OM400412+)
13	REC805536A2	805536A2	CRUCETA CARDAN (-OM400411)	U-JOINT (-OM400411)	CROCETTA (-OM400411)
13	REC865496A02	865496A02	CRUCETA CARDAN (OM400412+)	U-JOINT (OM400412+)	CROCETTA (OM400412+)
14	REC393831	393831	CARDAN (-OM400411)	SOCKET (-OM400411)	CARDAN (-OM400411)
14	REC865503T	865503T	CARDAN (OM400412+)	SOCKET FROM (OM400412+) (GKN)	CARDAN (OM400412+)
15	REC853635	853635	UNIÓN COLA CARDÁN (-OM400411)	YOKE (-OM400411)	UNIONE PIEDE -CARDAN (-OM400411)
15	REC864282T	864282T	UNIÓN COLA CARDÁN (OM400412+)	YOKE (OM400412+)	UNIONE PIEDE - CARDAN (OM400412+)
16	REC8168112	8168112	RETENEDOR	RETAINER	TENUTA
17	REC35983	35983	ANILLO	RING	ANELLO
18	REC25-70937	25-70937	ARO	O-RING	ANELLO
19	REC66081A2	66081A2	CUERPO RETÉN CARDAN	CARRIER ASSEMBLY	TENUTA
20	REC26-823894	26-823894	RETÉN ACEITE	OIL SEAL	PARAOLIO
21	REC31-30894A5	31-30894A5	KIT COJINETE	BEARING KIT	KIT CUSCINETTO
22	REC15-35980A1	15-35980A1	SUPLEMENTO	SHIM	SPESSORE
23	REC15-71013	15-71013	ESPACIADOR	SPACER	DISTANZIALE
24	REC12-45810	12-45810	ARANDELA	WASHER	RONDELLA
25	REC11-22339	11-22339	TUERCA	NUT	DADO
26	REC10-79953Q04	10-79953Q04	KIT TORNILLOS	SCREW KIT	KIT VITE
27	REC12-191833	12-191833	ARANDELA	WASHER	RONDELLA
28	REC11-859135	11-859135	TUERCA	LOCKNUT	DADO
29	REC12-45176	12-35935	ARANDELA	WASHER	RONDELLA
30	REC10-816601	10-816601	TORNILLO	BOLT	VITE
31	REC24-17997A1	24-17997A1	KIT BOLA ENGRASE	SPRINT KIT	KIT BOLLA ENGRASSATORE
32	REC26-88397	26-88397	GRUESO	GROMMET	SPESSORE
33	REC32-860220	32-860220	TUBO GUÍA	GUIDE TUBE	TUBO GUIDA
34	CM821629	821629Q1	ANODO ZINC	ZINC ANODE	ANODO ZINCO
34	CM821629A	821629Q1	ANODO ALUMINIO	ALUMINUM ANODE	ANODO ALLUMINIO
36	REC10-28668	10-28668	TORNILLO	SCREW	VITE
37	REC10-98794	10-98794	TORNILLO	SCREW	VITE
40	REC828692A1	828692A1	TAPA SUPERIOR	COVER ASSEMBLY	COPERCHIO
41	RM815932	815932	SEPARADOR ESCAPE	FILLER WALL	SEPARATORE
42	REC8M2015937	8M2015937	GRUESO BABOR	WEAR PAD - PORT	SPESSORE BABORDO
42	REC8M2015938	8M2015938	GRUESO ESTRIBOR	WEAR PAD - STARBOARD	SPESSORE TRIBORDO

**ALPHA ONE GEN II STD & COUNTER ROTATION**

Ref.	R.O.	OEM
REC26-816575A3	26-816575A3	



Kit reparación  
Gearcase seal kit  
Kit riparazione

Ref.	R.O.	OEM
REC11-52707Q1	11-52707Q1	



Kit cierre hélice  
Propeller nut kit  
Kit chiusura elicha

Ref.	R.O.	OEM
REC43-878087A2	43-878087A2	



KIT PIÑÓN RODAMIENTO (13:21)  
Includes rodamiento REC31-30894A1 (1996+)  
Pinion and forward gear set. Includes forward bearing REC31-30894A1 (1996+)  
KIT PIGNONI (13:21)  
Include cuscinetto REC31-30894A1 (1996+)

Ref.	R.O.	OEM
RM23-815921A17	23-815921A17	



Casquillo corredera  
Bushing  
Ghiera scorrevole

Ref.	R.O.	OEM
CM806105	806105Q1	Zn
CM806105A	806105Q1	Al



Ánodo eje hélice  
Prop shaft anode  
Anodo asse elica

Ref.	R.O.	OEM
CMALPHA KITA	Al	
CMALPHA KITM	MG	
TENKITALPHAONE/2	ZN	



Kit ánodos  
Anode kit  
Kit anodi

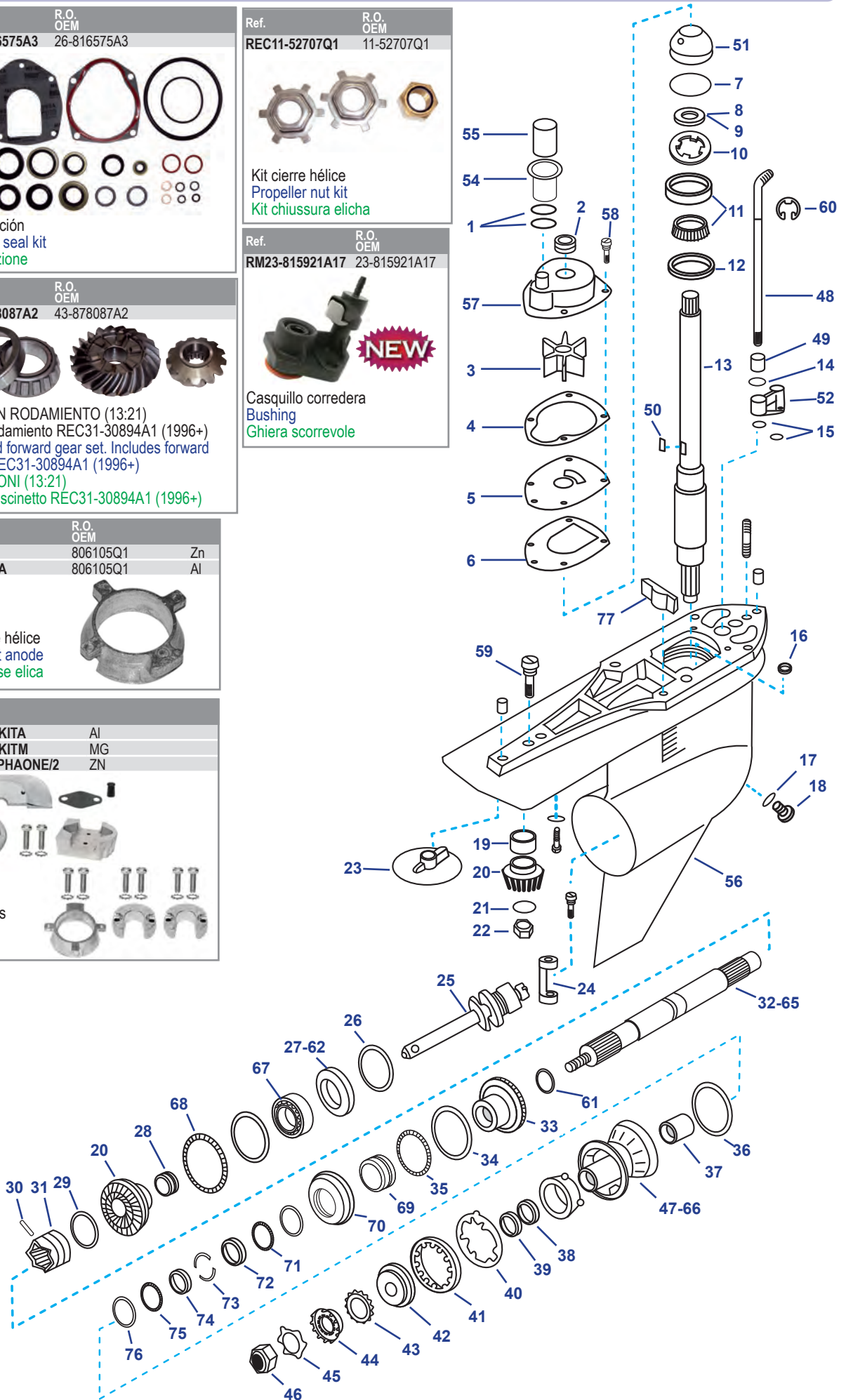

Nº	Ref.	R.O. OEM	Descripción	Description	Descrizione
1	REC25-21836	25-21836	ARO TÓRICO	O-RING	FASCE
2	REC26-816575A2	26-816575A2	RETÉN GOMA	SEAL	TENUTA
3	REC47-43026Q02	47-43026Q02	IMPULSOR	IMPELLER	GIRANTE
4	REC27-8172771	27-8172771	JUNTA	GASKET	GUARNIZIONE
5	REC8172761	8172761	TAPA BOMBA AGUA	PUMP CAP	COPERCHIO POMPA
6	REC27-430331	27-430331	JUNTA	GASKEET	GUARNIZIONE
7	REC25-90011	25-90011	ARO TÓRICO	O-RING	ANELLO
8	REC26-66302	26-66302	RETÉN ACEITE (-0M400411)	OIL SEAL (-0M400411)	PARAOLIO (-0M400411)
9	REC26-864319	26-864319	RETÉN ACEITE (0M400411+)	OIL SEAL (0M400411+)	PARAOLIO (0M400411+)
10	REC8245191	8245191	RETENEDOR	SEAL	TENUTA
11	REC31-36387A1	31-36387A1	RODAMIENTO	BEARING	CUSCINETTO
11	REC31-33138A1	31-33138A1	RODAMIENTO (1998+)	BEARING (1998+)	CUSCINETTO (1998+)
12	REC15-42637A1	15-42637A1	GRUESO	SHIM	SPESSORE
13	REC45-816919	45-816919	EJE TRANSMISIÓN (-999999)	SHAFT (-999999)	ASSE (-999999)
13	REC45-853648	45-853648	EJE TRANSMISIÓN (OL100040+)	SHAFT (OL100040+)	ASSE (OL100040+)
14	REC26-8164641	26-816464-1	RETÉN ACEITE	OIL SEAL	PARAOLIO
15	REC25-36318	25-36318	ARO TÓRICO	O-RING	ANELLO
16	REC26-455771	26-45577-1	RETÉN	SEAL	TENUTA
17	REC12-191833	12-191833	JUNTA TAPÓN	CAP GASKET	GUARNIZIONE TAPPO
18	REC22-67892A05	8M0058389	TAPÓN	CAP	TAPPO
19	REC387817	31-42647A1	RODAMIENTO	BEARING	CUSCINETTO
20	REC43-878087A2	43-878087A2	KIT PINONES (1996+) 13:21 1.47, 1.62, 1.81, 1.94 Ratio 3.265 OD Avante	PINION SET(1996) 13:21 1.47, 1.62, 1.81, 1.94 Ratio 3.265 OD Forward bearing	KIT PIGNONE (1996) 13:21 1.47, 1.62, 1.81, 1.94 Rapporto 3.265 OD Avanti
20	REC43-878617A2	43-853592A2	KIT PINONES (1998+) 2.00:1 / 2.40:1 3.265 OD Avante	PINION SET (1998+) 2.00:1 / 2.40:1 3.265 OD Forward bearing	KIT PIGNONE (1998+) 2.00:1 / 2.40:1 3.265 OD Avanti
21	REC350038	12-92721	JUNTA	GASKET	GUARNIZIONE
22	REC11-35921	11-35921	TUERCA	NUT	DADO
23	CM762145	76214Q5	ÁNODO ZINC	ANODE ZINC	ANODO ZINCO
23	CM762145A	76214Q5	ÁNODO ALUMINIO	ANODE ALUMINIUM	ANODO ALLUMINIO
24	REC76865	76865	HORQUILLA CAMBIO	CLIP	CLIP
25	REC818349T1	818349T1	EJE DESPLAZABLE	SHAFT	ASSE
26	REC15-47397A1	15-47397A1	GRUESO (1991-95)	SHIM (1991-95)	SPESSORE (1991-95)
26	REC15-44491A1	15-44491A1	GRUESO (1996+)	SHIM (1996+)	SPESSORE (1996+)
27	REC31-828437A2	31-828437A2	COJINETE Ø 44,45 - 88,9 mm	BEARING Ø 44,45 - 88,9 mm	CUSCINETTO Ø44,45 - 88,9 mm
27	REC31-35928T1	31-35928T1	COJINETE Ø 47,62 - 88,9 mm	BEARING Ø 47,62 - 88,9 mm	CUSCINETTO Ø 47,62 - 88,9 mm
27	REC31-30894A1	31-30894A1	COJINETE Ø 44,45-82,93 mm	BEARING Ø 44,45-82,93 mm	CUSCINETTO Ø 44,45-82,93 mm
27	REC31-828439A2	31-828439A2	COJINETE Ø 47,62 - 82,93 mm	BEARING Ø 47,62 - 82,93 mm	CUSCINETTO Ø 47,62 - 82,93 mm
28	REC31-30895T	31-30895T	RODAMIENTO STD	BEARING STD	CUSCINETTO STD
28	REC31-15844	31-15844	RODAMIENTO CONTRAROTACIÓN	BEARING COUNTER ROTATION	CUSCINETTO CONTRO ROTANTE
29	REC24-30893	24-30893	MUELLE	SPRING	MOLLA
30	REC17-8M0084681	8M0020941	PASADOR	PIN	SPINOTTO
31	REC52-853594T	52-853594T	SELECTOR	GEAR	PIGNONE
32	REC44-824110	44-824110	EJE HÉLICE (91-97) (-999999)	SHAFT PROPELLER (91-97) (-999999)	ASSE ELICA (91-97) (-999999)
32	REC44-850308	44-850308	EJE HÉLICE (1998+) (OL100040+)	SHAFT PROPELLER (1998+) (OL100040+)	ASSE ELICA (1991-97) (OL100040+)
33	REC43-828073A1	43-828073A1	PINÓN MARCHA ATRÁS STD	GEAR REVERSE STD	PIGNONE MARCIA INDIETRO STD
34	REC681001	681001	ARO	RING	ANELLO
35	REC30-88957T	30-88957T1	RODAMIENTO STD	BEARING STD	CUSCINETTO STD
36	REC25-31534	25-31534	ARO TORICO	O-RING	FASCE
37	REC387247	31-30956T	RODAMIENTO	BEARING	CUSCINETTO
38	REC26-76868	26-14077	RETÉN ACEITE Interior	OIL SEAL Inside	PARAOLIO interno
39	REC26-12224	26-12224	RETÉN ACEITE Exterior	OIL SEAL Outside	PARAOLIO esterno
40	REC14-18323	14-18323	TAPA	CAP	COPERCHIO
41	REC8M2011027	8M2011027	TUERCA	NUT	DADO
42	REC12-835467Q01	12-835467Q01	SEPARADOR	SPACER	DISTANZIALE
43	REC13-423511	13-423511	CIERRE	CLIP	CHIUSURA
44	REC12-31211Q03	12-31211A2	TOPE CIERRE HÉLICE	END CLIP	TAPPO CHIUSURA ELICA
45	REC90508-ZW1-003	14-816629Q	CIERRE	CLIP	CHIUSURA
46	REC90301-ZW1-003	11-827614	TUERCA	NUT	DADO
47	REC818763A10	818763A10	COJINETE COLA STD	BEARING STD	CUSCINETTO STD
48	REC815919A1	815919A1	EJE CAMBIO	DRIVE SHAFT	ASSE
49	REC23-67370	23-67370	LEVA	CAM	BOCCOLA
50	REC28-8M0032833	28-8M0032833	CHAVETA	CLIP	CHIAVE
51	REC807929A1	807929A1	PORTA RETÉN (1991+)	SEAL BASE (1991+)	BASE TENUTA (1991+)
52	REC23-815921A21	23-815921A21	CASQUILLO	SHIFT BUSHING	BOCCOLA
54	REC816597A1	816597A1	TUBO AGUA	TUBE	TUBO
55	REC23-816583	23-816583	TUBO	TUBE	TUBO
56	REC1623-815822A30	1623-815822A30	CARCASA COLA (OD469859-999999)	HOUSING (OD469859-999999)	CARCASSA (OD469859-999999)
57	RM817275A1	817275A1	TAPA BOMBA AGUA	CAP WATER PUMP	COPERCHIO POMPA ACQUA
58	REC10-816928	10-816928	TORNILLO	BOLT	VITE
59	REC10-806327	10-806327	TORNILLO	BOLT	VITE
60	REC53-29641	53-29641	CIERRE	CIRCLIP	CIRCLIP
61	REC23-824108	23-824108	SUPLEMENTO	SHIM	SPESSORE
62	REC828830A2	828830A2	COJINETE ADAPTADOR CONTRA ROTACIÓN	BEARING ADAPTOR COUNTER ROTATION ASSY	CUSCINETTO ADATTATORE CONTRO ROTANTE
65	REC44-8146061	814606 1	EJE CONTRA ROTACIÓN (1991-95)	PROPSHAFT COUNTER ROTATION (1991-95)	ASSE CONTRO ROTANTE (1991-95)
66	REC14587A7	14587A5	COJINETE CONTRA ROTACIÓN (1991-95)	BEARING CARRIER COUNTER ROT. (1991-95)	CUSCINETTO CONTRO ROT.(1991-95)
67	REC31-814653T	31-814653	COJINETE CONTRA ROTACIÓN	BEARING CARRIER COUNTER ROTATION	CUSCINETTO CONTRO ROTANTE
68	REC31-815480	31-815480	COJINETE ALPHA (1996+) CONTRA ROT.	BEARING ALPHA (1996+) COUNTER ROT.	CUSCINETTO ALPHA (1996+) CONTRO ROTANTE
69	REC31-814653T	31-814653	ARANDELA CONTRA ROTACIÓN	WASHER COUNTER ROTATION	RONDELLA CONTRO ROTANTE
70	REC814604T1	814604A1	RODAMIENTO CONTRA ROTACIÓN	BEARING COUNTER ROTATION	CUSCINETTO CONTRO ROTANTE
71	REC31-15842	31-15842	COJINETE RODILLOS CONTRA ROTACIÓN	NEEDLE BEARING COUNTER ROTATION	CUSCINETTO CONTRO ROTANTE
72		815570	TOPE EJE CONTRA ROTACIÓN	THRUST WASHERS PROPSHAFT COUNTER ROTATION	ANELLO FINE CORSA CONTRO ROT.
73	REC814605	814605	CIERRE CONTRA ROTACIÓN	KEEPERS PROPSHAFT COUNTER ROT.	CHIUSURA CONTRO ROTANTE
74		815570	TOPE EJE CONTRA ROTACIÓN	THRUST WASHERS PROPSHAFT COUNTER ROTATION	ANELLO FINE CORSA CONTRO ROTANTE
75	REC31-15842	31-15842	COJINETE RODILLOS CONTRA ROTACIÓN	NEEDLE BEARING COUNTER ROTATION	CUSCINETTO CONTRO ROTANTE
76	REC12-18448	12-18448	ARANDELA CIERRE CONTRA ROTACIÓN	WASHER CLOSURE COUNTER ROT.	RONDELLA CHIUSURA CONTRO ROT.
77	REC821526001	861526001	RETÉN DE GOMA	RUBBER SEAL	PARAOLIO IN GOMMA

BRAVO

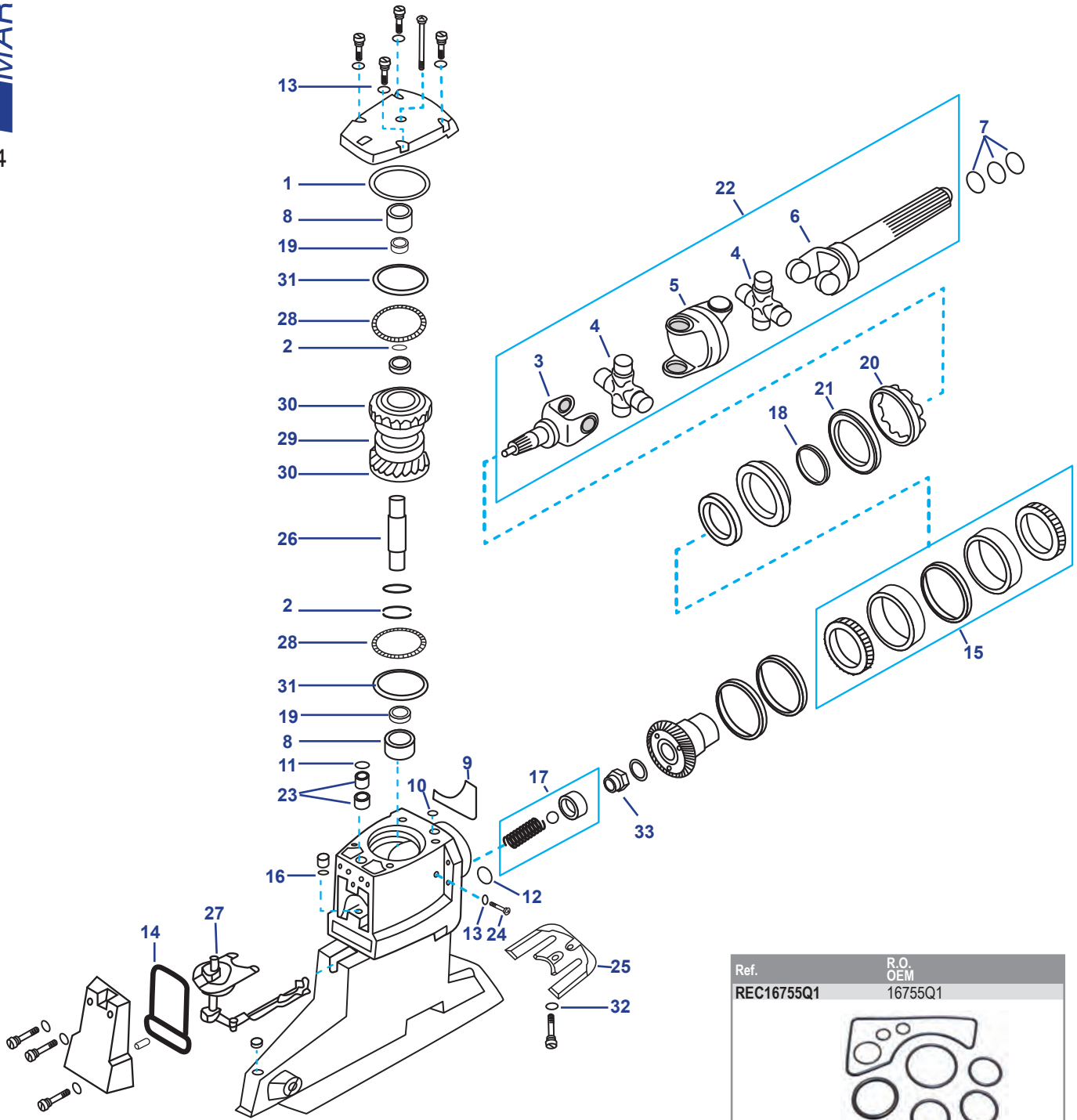

Ref.	R.O. OEM
REC16755Q1	16755Q1
Kit retenes Gearcase seal kit Kit tenuta	

Ref.	R.O. OEM
REC23-861209A1	23-861209A1
Kit retenes BRAVO Shift shaft bushing BRAVO Kit tenutes BRAVO	

Ref.	R.O. OEM
REC87580	
Kit reparación TR, TRS Gearcase seal kit TR, TRS Kit riparazione TR, TRS	

Ref.	R.O. OEM
REC26-16709A2	26-16709A2
Kit reparación BRAVO I, II, III Gearcase seal kit BRAVO I, II, III Kit riparazione BRAVO I, II, III	

Nº	Ref.	R.O. OEM	Descripción	Description	Descrizione
1	REC25-97387	25-97387	ARO TÓRICO	O-RING	ANELLO
2	RM97351	97351	RETENEDOR	RETAINER	TENUTA
3	REC12784	12784	UNIÓN COLA-CARDAN	YOKE	ASSE PIEDE-CARDANO
4	REC3850812	75832	CRUCETA	U-JOINT	CROCETTA
4	RM866136A01	866136A01	CRUCETA (OM750175+) GKN	U-JOINT (OM750175+) GNK	CROCETTA (OM750175+) GNK
4	REC862132T	862132T	CRUCETA BRAVO X, XR, XZ	U-JOINT BRAVO X, XR, XZ	CROCETTA BRAVO X, XR, XZ
4	REC865496A02	865496A01	CRUCETA BRAVO (0M111208+)	U-JOINT BRAVO (0M111208+)	CROCETTA BRAVO (0M111208+)
5	REC393831	393831	CARDÁN (-0M111207)	SOCKET (-0M111207)	CARDANO (-0M111207)
6	REC59830A7	814819A3	UNIÓN COLA MOTOR	YOKE ASSY	ASSE PIEDE
7	REC25-29845	25-29845	ARO TÓRICO (.924 x 1.03)	O-RING (.924 x 1.03)	ANELLO (.924 x 1.03)
7	REC25-35027	25-35027	ARO TÓRICO (1.046)	O-RING (1.046)	ANELLO (1.046)
8	REC31-815900	31-815900	COJINETE	BEARING	CUSCINETTO
9	REC86310	16755Q1	RETÉN	REATINER	TENUTA
10	REC25-62706	25-62706	ARO TÓRICO (.426 x 0.70)	O-RING (.426 x 0.70)	ANELLO (.426 x 0.70)
11	REC25-62705	25-62705	ARO TÓRICO	O-RING	ANELLO
12	REC25-457101	25-457101	ARO TÓRICO (1.424 x 103)	O-RING (1.424 x 103)	ANELLO (1.424 x 103)
13	REC12-191833	12-191833	JUNTA	GASKET	GUARNIZIONE
14	REC12708	12708	RETÉN	RETAINER	TENUTA
15	REC31-86763A2	31-86763A2	RODAMIENTO (- OM198372)	BEARING (-OM198372)	CUSCINETTO (-OM198372)
15	RM31-86763A04	31-86763A04	RODAMIENTO (OM198373+)	BEARING (OM198373+)	CUSCINETTO (-OM198373+)
16	REC26-12709	26-127091	RETÉN ACEITE	OIL SEAL	PARAOLIO
17	REC24-17997A1	24-17997A1	JUEGO MUELLE	SPRING SET	KIT MOLLA
18	REC26-807006	26-807006	RETÉN ACEITE	OIL SEAL	PARAOLIO
19	REC31-87156	31-87156	COJINETE	BEARING	CUSCINETTO
20	RM11-92004	11-92004	TUERCA	NUT	DADO
21	REC86779A1	86779A1	PORTA RETÉN	RING	ANELLO
22	REC864244A2	864244A2	KIT TRANSMISIÓN BRAVO (0B664190+) (1985-05)	U-JOINT ASSEMBLY BRAVO (0B664190+) (1985-05)	KIT TRASMISSIONE BRAVO (0B664190+) (1985-05)
22	RM865425A03	865425A03	KIT TRANSMISIÓN COLAS BRAVO X, XR, XZ	U-JOINT ASSEMBLY BRAVO X, XR, XZ	KIT TRASMISSIONE BRAVO X, XR, XZ
23	REC23-861209A1	23-861209A1	RETÉN	RETAINER	TENUTA
24	REC22-67892A05	8M0058389	TORNILLO	SCREW	VITE
25	CM821630	821630Q1	ÁNODO ZINC	ANODE ZINC	ANODO ZINCO
25	CM821630A	821630Q1	ÁNODO ALUMINIO	ANODE ALLUMINIUM	ANODO ALLUMINIO
26	RM45-812773T	45-812773	EJE TRANSMISIÓN	DRIVE SHAFT	ASSE
27	REC12711	12711	EJE SELECTOR	SHAFT	ASSE SELETTORE
28	REC31-86771	31-86771	COJINETE	BEARING	CUSCINETTO
29	RM52-865344A01	52-865344A01	CURSOR	CLUTCH	CURSORE
30	RM43-887906A1	43-887906A1	KIT PIÑONES (29/27) BRAVO I. 1.36:1 BRAVO II. 1.50:1 Y 1.81:1 BRAVO III.1.36:1 Y 1.81:1	BEARING KIT (29/27) BRAVO I. 1.36:1 BRAVO II. 1.50:1 & 1.81:1 BRAVO III.1.36:1 & 1.81:1	KIT PIGNONE (29/27) BRAVO I. 1.36:1 BRAVO II. 1.50:1 E 1.81:1 BRAVO III.1.36:1 E 1.81:1
30	RM43-887903A1	43-887903A1	KIT PIÑONES (32/27) BRAVO I. 1.50:1 BRAVO II. 1.65:1 Y 2.00:1 BRAVO III. 1.65:1 Y 2.00:1	BEARING KIT (32/27) BRAVO I. 1.50:1 BRAVO II. 1.65:1 & 2.00:1 BRAVO III.1.65:1 & 2.00:1	KIT PIGNONE (32/27) BRAVO I. 1.50:1 BRAVO II. 1.65:1 E 2.00:1 BRAVO III.1.65:1 E 2.00:1
30	RM43-887909A1	43-887909A1	KIT PIÑONES (30/23) BRAVO I. 1.65:1 BRAVO II. 2.20:1 BRAVO III. 2.20:1 Y 2.43:1	BEARING KIT (30/23) BRAVO I. 1.65:1 BRAVO II. 2.20:1 BRAVO III. 2.20:1 & 2.43:1	KIT PIGNONE (30/23) BRAVO I. 1.65:1 BRAVO II. 2.20:1 BRAVO III. 2.20:1 E 2.43:1
31	RM23-87560091	23-87560091	GRUESO. 091 ROJO	SHIM. 091 RED	SPESSORE. 091 ROSSO
31	RM23-87560094	23-87560094	GRUESO. 094 AZUL	SHIM. 094 BLUE	SPESSORE. 094 BLU
31	RM23-87560097	23-87560097	GRUESO. 097 VERDE	SHIM. 097 GREEN	SPESSORE. 097 VERDE
32	REC13-35048	13-35048	ARANDELA	WASHER	RONDELLA
33	REC11-22339	11-22339	TUERCA	NUT	DADO

**BRAVO I**

Ref.	R.O. OEM
REC26-76868A04	26-76868A04



Kit reparación BRAVO I, II, III  
Gearcase seal kit BRAVO I, II, III  
Kit riparazione BRAVO I, II, III

Ref.	R.O. OEM
CM806188	
CM806188A	Al



Ánodo  
Anode  
Anodo

Ref.	R.O. OEM
CMBRAVO1KITA	Al
CMBRAVO1KITM	MG
TENKITBRAVOI	ZN



Ánodo  
Anode  
Anodo

Ref.	R.O. OEM
REC11-52707Q1	11-52707Q1



Kit cierre hélice  
Propeller nut kit  
Kit chiusura elica

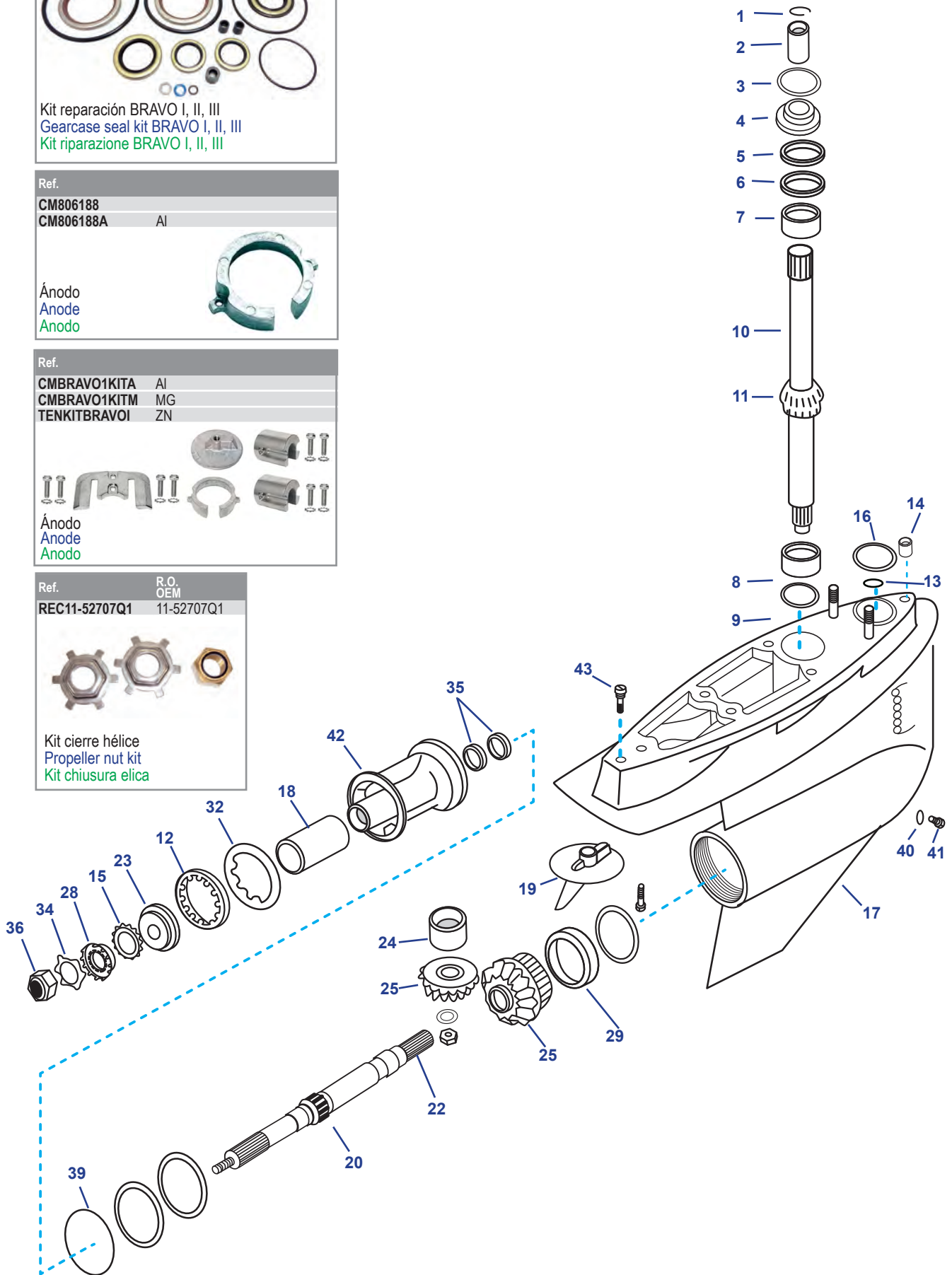

Nº	Ref.	R.O. OEM	Descripción	Description	Descrizione
1	REC53-88242	53-88242	CLIP	CLIP	CLIP
2	REC88243A3	88243A3	ACOPLE	COUPLING ASSEMBLY	ASSE ACCOPPIAMENTO
3	REC308627	25-20826	ARO TÓRICO	O-RING	ANELLO
4	REC23-8M8000506	23-92916	ESPACIADOR	SPACER	DISTANZIALE
5	REC15-86749A1	15-86749A1	KIT SUPLEMENTOS	SHIM KIT	KIT SPESSORE
6	RM86739	14-86739	ARANDELA	WASHER	RONDELLA
7	REC31-86748A1	31-86748A1	COJINETE	BEARING	CUSCINETTO
8	REC31-66668A1	66668A1 31-99328A1	COJINETE	BEARING	CUSCINETTO
9	REC15-92914A1	15-92914A1	KIT GRUESOS	SHIM KIT	KIT SPESSORE
10	RM45-41629A2	41629A2	EJE TRANSMISIÓN	DRIVESHAFT	ASSE TRASMISSIONE
11	REC31-86748A1	31-86748A1	COJINETE	BEARING	CUSCINETTO
12	REC8M2011027	8M2011027	TUERCA	NUT	DADO
13	REC25-33465	25-33465 25-822370	ARO TÓRICO (2.362 x .103)	O-RING (2.362 x .103)	ANELLO (2.362 x .103)
14	REC26-36556	26-36556	TUBO AGUA Ø EXT. 12.7 mm	WATER TUBE Ø EXT. 12.7mm	TUBO ACQUA Ø EXT. 12.7 mm
14	REC26-805344	26-805344	TUBO AGUA Ø EXT. 15.88 mm	WATER TUBE Ø EXT. 15.88 mm	TUBO ACQUA Ø EXT. 15.88 mm
15	REC13-423511	13-42351-1	CIERRE	LOCK	CHIUSURA
16	REC26-455771	26-455771	RETÉN	SEAL	TENUTA
17	RM1656-8866A17	8866A64	CARCASA COLA (1656-8863CZ)	LOWER CASE (1656-8863CZ)	CARCASSA PIEDE (1656-8863CZ)
18	REC31-54042T	31-54042T	COJINETE	BEARING	CUSCINETTO
19	CM762145	76214Q5	ÁNODO ZINC	ZINC ANODE	ANODO ZINCO
19	CM762145A	76514Q5	ÁNODO ALUMINIO	ALUMINIUM ANODE	ANODO ALLUMINIO
20	REC31-66668A1	66668A1 31-99328A1	COJINETE	BEARING	CUSCINETTO
22	RM44-41630T	44-850308 44-41630T	EJE HÉLICE	PROPSHAFT	ASSE ELICA
23	REC12-835467Q01	12-835467Q01	TOPE HÉLICE	SEPARATOR	FERMO PER ELICA
24	REC31-86754T	31-86754T	COJINETE	BEARING	CUSCINETTO
25	RM43-14063A1	43-14063A1	KIT PIÑONES (15/19)	BEARING SET (15/19)	KIT CUSCINETTO (15/19)
28	REC12-31211Q03	12-31211Q03	TOPE CIERRE HÉLICE	WASHER	TAPPO CHIUSURA ELICA
29	REC31-86752A1	31-86752A1	COJINETE	BEARING	CUSCINETTO
32	REC14-18323	14-18323	ARANDELA	WASHER	RONDELLA
34	REC90508-ZW1-003	14-816629Q	ARANDELA CIERRE	LOCK WASHER	RONDELLA CHIUSURA
35	REC26-76868	26-76868	RETÉN ACEITE	OIL SEAL	PARAOILIO
36	REC90301-ZW1-003	11-827614	TUERCA CIERRE HÉLICE	LOCK NUT	DADO CHIUSURA
39	REC25-31534	25-31534	ARO TÓRICO	O-RING	ANELLO
40	REC12-191833	12-191833	JUNTA	GASKET	GUARNIZIONE
41	REC22-67892A05	8M0058389	TORNILLO DRENAJE	DRAIN PLUG	VITE DRENAGGIO
42	REC41641A8	41641A8	COJINETE COLA	BEARING	CUSCINETTO
43	REC10-806327	10-806327	TORNILLO	SCREW	VITE

**PARTE INFERIOR COMPLETA**  
**COMPLETE GEAR HOUSING ASSEMBLY**  
**PARTE INFERIORE COMPLETA**

Ref.	R.O. OEM	ENTRADAS DE AGUA WATER INTAKE PRESA D'ACQUA
REC1656-8866A55	1656-8866A55 1656-8866A10	1
REC1656-8866A63	1656-8866A63 1656-8866A15	2





**BRAVO II**

Ref.	
CMBRAVO2Y3KITA	Al
CMBRAVO2Y3KITM	MG
TENKITBRAVOII-III	ZN

Ánodo  
 Anode  
 Anodo

Ref.	
CM806188	
CM806188A	Al

Ánodo  
 Anode  
 Anodo

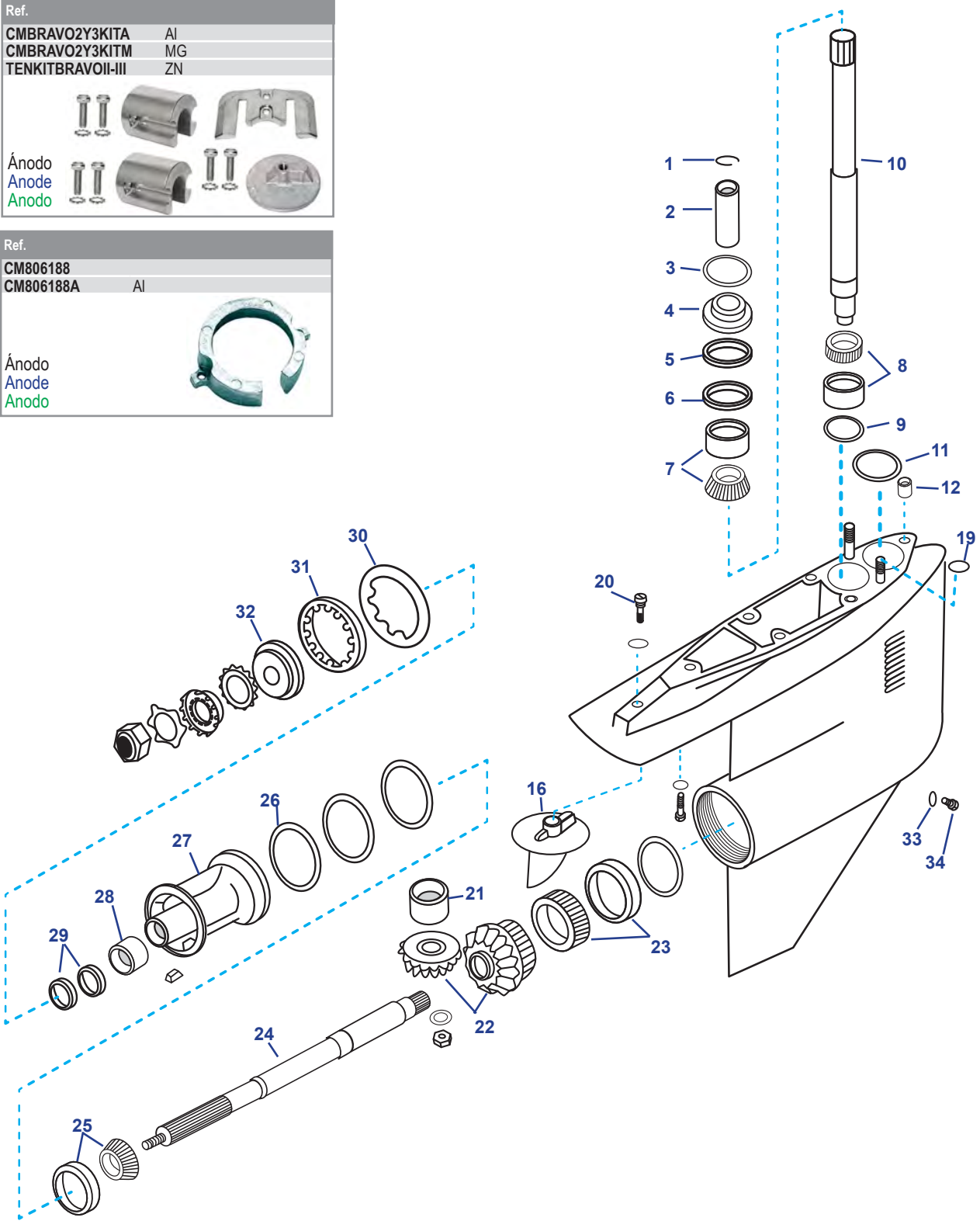

Ref.	R.O. OEM
REC26-76868A04	26-76868A04

Kit reparación BRAVO I, II, III  
 Gearcase seal kit BRAVO I, II, III  
 Kit riparazione BRAVO I, II, III

Nº	Ref.	R.O. OEM	Descripción	Description	Descrizione
1	REC53-88242	53-88242	CLIP	CLIP	CLIP
2	REC88243A3	88243A3	ACOPLE	COUPLING ASSEMBLY	ACCOPIAMENTO
3	REC308627	25-20826	ARO TÓRICO	O-RING	ANELLO
4	REC23-8M8000506	92916	ESPACIADOR	SPACER	DISTANZIALE
5	REC15-86749A1	15-86749A1	KIT GRUESOS	SHIM KIT	KIT SPESSORE
6	RM86739	14-86739	ARANDELA	WASHER	RONDELLA
7	REC31-86748A1	31-86748A1	COJINETE	BEARING	CUSCINETTO
8	REC31-66668A1	31-66668A1	COJINETE	BEARING	CUSCINETTO
9	REC15-92914A1	15-92914A1	KIT GRUESOS	SHIM KIT	KIT SPESSORE
10	RM45-41629A2	45-41629A2	EJE	DRIVESHAFT	ASSE
11	REC25-33465	25-822370	ARO	O-RING	ANELLO
12	REC26-805344	26-805344	RETÉN AGUA Ø15.88 mm	SPEEDOMETER SEA Ø15.88 mm	TENUTA ACQUA Ø15.88 mm
12	REC26-36556	26-36556	RETÉN AGUA Ø 12.7 mm	SPEEDO GROMMET Ø 12.7 mm	TENUTA ACQUA Ø 12.7 mm
16	CM762144	76214A2	ÁNODO ZINC	ZINC ANODE	ANODO ZINCO
16	CM762144A	76214A2	ÁNODO ALUMINIO	ANODE ALLUMINIUM	ANODO ALUMINIO
19	REC26-455771	26-455771	RETÉN	SEAL	PARAOLIO
20	REC10-806327	10-806327	TORNILLO ANODO	ANODE SCREW	VITE ANODO
21	REC31-86754T	31-86754T	COJINETE	BEARING	CUSCINETTO
22	RM43-14063A1	43-14063A1	KIT PIÑONES (15/19)	GEAR SET (15/19)	KIT PIGNONI (15/19)
23	REC31-86752A1	31-86752A1	COJINETE	BEARING	CUSCINETTO
24	RM44-41630T	44-41630T	EJE HÉLICE	PROP SHAFT	ASSE ELICA
25	REC31-66668A1	31-66668A1	COJINETE	BEARING	CUSCINETTO
26	REC25-31534	25-31534	TÓRICA	O-RING	TENUTA
27	REC41641A8	41641A8	COJINETE COLA	BEARING CARRIER	CUSCINETTO PIEDE
28	REC31-54042T	31-54042T	COJINETE	BEARING	CUSCINETTO
29	REC26-76868	26-76868	RETÉN	SEAL	PARAOLIO
30	REC14-18323	14-18323	ARANDELA	LOCK WASHER	RONDELLA
31	REC8M2011027	79448	TUERCA CIERRE COLA	LOCK NUT	RONDELLA CHIUSURA PIEDE
32	REC12-835467Q01	13171	TOPE HELICE	SEPARATOR	FERMO PER ELICA
33	REC12-191833	12-191833	JUNTA	GASKET	GUARNIZIONE
34	REC22-67892A05	22-67892	TORNILLO CON RETÉN CIERRE	DRAINING SCREW SET	VITE CON PARAOLIO CHIUSURA

**BRAVO III**

Ref.	R.O. OEM
REC26-76868A04	26-76868A04



Kit reparación BRAVO I, II, III  
Gearcase seal kit BRAVO I, II, III  
Kit riparazione BRAVO I, II, III

Ref.	
CMPNDAF14UNS	Zn
CMPNDAF14UNSA	Al



Kit ánodo BRAVO III (-2003)  
Anode kit BRAVO III (-2003)  
Kit anodo BRAVO III (-2003)

Ref.	
CM806188	
CM806188A	Al



Ánodo  
Anode  
Anodo

Ref.	
CMBRAVO3KITA	Al
CMBRAVO3KITM	MG
TENKITBRAVOIII-04	ZN



Ánodo  
Anode  
Anodo

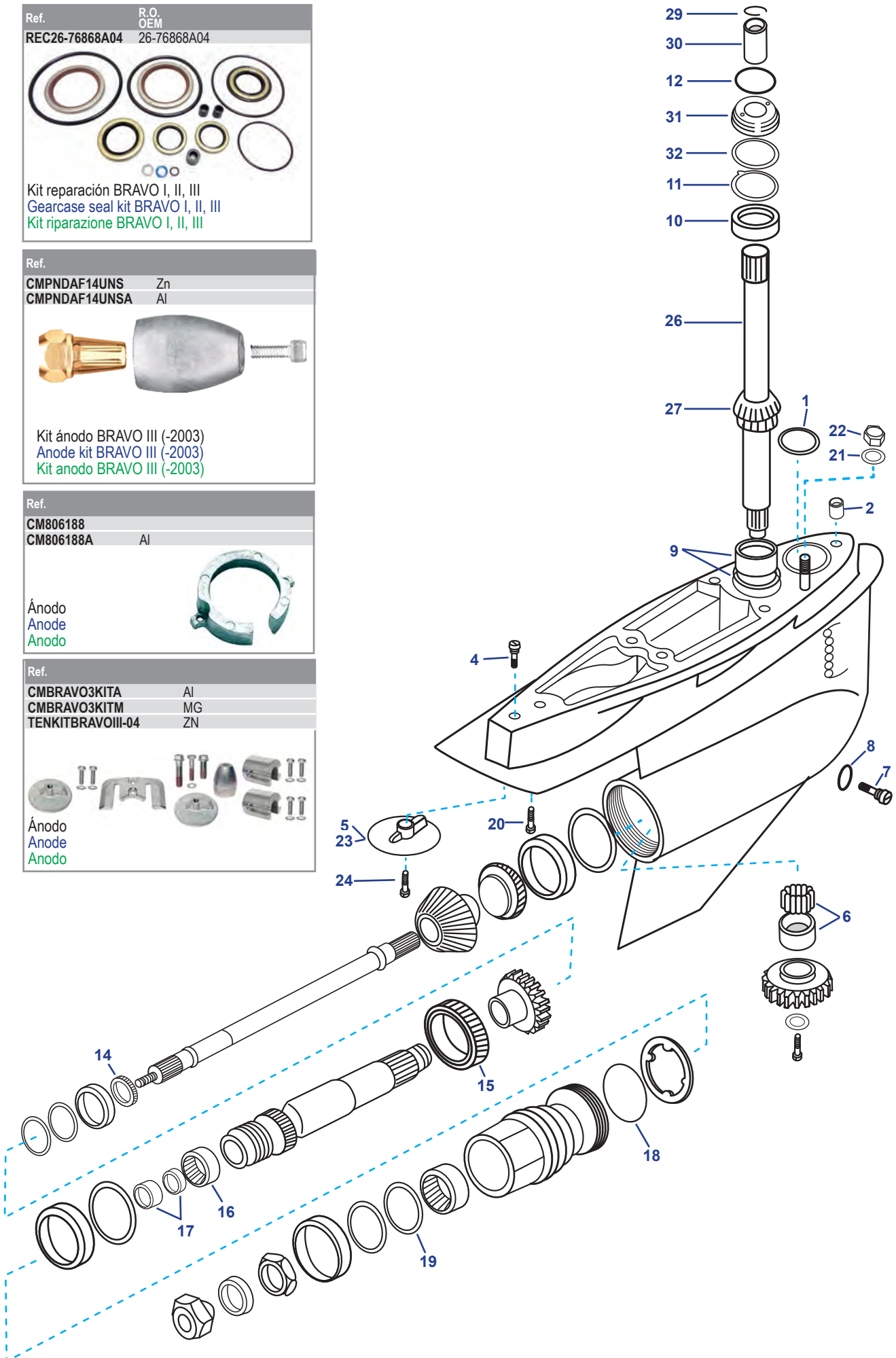

Nº	Ref.	R.O. OEM	Descripción	Description	Descrizione
1	REC25-33465	25-33465	ARO TÓRICO	O-RING	ANELLO
2	REC26-805344	26-805344	RETÉN	SEAL	TENUTA
3	REC26-455771	26-45577-1	RETÉN	SEAL	TENUTA
4	REC10-806327	10-806327	TORNILLO	SCREW	VITE
5	CM762144	76214Q5	ÁNODO	ANODE	ANODO
6	RM86754T	86754T	COJINETE	BEARING	CUSCINETTO
7	REC22-67892A05	22-8M0058389	TORNILLO CON RETÉN	DRAININ SCREW SET	VITE CON TENUTA
8	REC12-191833	12-19183-3	JUNTA	GASKET	GUARNIZIONE
9	REC31-66668A1	31-99328A1	COJINETE	BEARING	CUSCINETTO
10	REC31-86748A1	31-86748A1	COJINETE	BEARING	CUSCINETTO
11	RM86739	86739	ARANDELA	WASHER	RONDELLA
12	REC308627	25-20826	ARO TÓRICO	O-RING	ANELLO
13	REC31-86752A1	31-86752A1	COJINETE	BEARING	CUSCINETTO
14	RM805322	805322	COJINETE	BEARING	CUSCINETTO
15	RM805182A1	805182A1	COJINETE	BEARING	CUSCINETTO
16	RM57410	57410	COJINETE	BEARING	CUSCINETTO
17	REC26-8M0033407	26-8M0033407	RETÉN ACEITE	OIL SEAL	PARAOILIO
18	REC3852865	25-805331	ARO TÓRICO	O-RING	ANELLO
19	REC26-861694	26-861694	RETÉN ACEITE	OIL SEAL	PARAOILIO
20	REC10-816601	10-816601	TORNILLO	SCREW	VITE
21	REC12-45176	12-45176	ARANDELA	WASHER	RONDELLA
22	REC11-34933	11-859116	TUERCA	NUT	DADO
23	CM762144A	76214Q5	ÁNODO ALUMINIO DESIGN II	ALUMINIUM ANODE DESIGN II	ANODO ALLUMINIO DESIGN II
24	REC313715	10-865321	TORNILLO	SCREW	VITE
25	RM44-865322T	44-865322T	EJE	SHAFT	ASSE
26	RM45-41629A2	805370A1	EJE (16.085 largo)	DRIVESHAFT (16.085 long)	ASSE (16.085 lungo)
27	REC31-86748A1	31-86748A1	COJINETE	BEARING	CUSCINETTO
29	REC53-88242	53-88242	RETÉN	SEAL	TENUTA
30	REC88243A3	88243A3	ACOPLE	COUPLING	ACCOPIAMENTO
31	REC23-8M8000506	23-92916	ESPACIADOR	SPACER	DISTANZIALE
32	REC15-86749A1	15-86749A1	KIT SUPLEMENTOS	SHIM KIT	SPESSORE KIT

# HERRAMIENTAS TOOLS ATTREZZI

## EXTRACTOR PIÑONES Y COJINETES UNIVERSAL PULLER PLATE ESTRATTORE PIGNONE E CUSCINETTI

Ref.	R.O. OEM	CAPACIDAD CAPACITY CAPACITÀ
REC91-37241	91-37241	75 - 105 mm 3" - 4 <sup>1</sup> / <sub>2</sub> "
REC91-00001		30 - 50 mm 1 <sup>1</sup> / <sub>4</sub> " x 2 <sup>1</sup> / <sub>4</sub> "
REC91-00002		50 - 75 mm 2 <sup>1</sup> / <sub>4</sub> " x 3 <sup>1</sup> / <sub>2</sub> "



## EXTRACTOR COJINETES DRIVER BEARING ESTRATTORE CUSCINETTI

Ref.	R.O. OEM
REC91-34569A1	91-34569A1



Ref.	R.O. OEM
REC91-36569T	91-36569T



MC-I, R-MR, Alpha One.

## EXPANSOR DE FUELLES BELLOWS EXPANDER TOOL ATTREZZO PER CUFFIE

Ref.	R.O. OEM
REC91-45497A1	91-45497A1

Instala los fuelles de escape en las MC-1/MR/Alpha One/ Alpha One Gene II, Bravo y Blackhawk.

Installs exhaust bellows on MC-1/R/MR/Alpha One/Alpha One Gen II, Bravo, and Blackhawk drive units.

Compatibile con MC-1/MR/Alpha One/ Alpha One Gene II, Bravo e Blackhawk.



## EXTRACTOR COJINETES Y HÉLICES PROP AND BEARING PULLER ESTRATTORE CUSCINETTI E ELICHE

Ref.	R.O. OEM
REC90095	

Extractor de cojinetes y hélices, con patas. Para todos los cojinetes Mercuriser y la mayoría de las hélices.

Prop and bearing carrier puller. Capacity: 5 Tons (Min). For Mercuriser All Style Bearing Carrier and Most Props.

Estrattore cuscinetti e eliche. Per tutti i cuscinetti Mercuriser e la maggior parte delle eliche.



Para hélices y cojinetes antiguos  
For prop and old style bearing carrier.  
Per eliche e cuscinetti vecchi.

Para cojinetes modernos  
For new style bearing carrier.  
Per cuscinetti moderni.

## KIT LLAVE HÉLICE PROP WRENCH KIT KIT CHIAVE ELICA

Ref.	R.O. OEM	TUERCA NUT DADO
REC91-859046Q4	91-859046Q4	1 <sup>1</sup> / <sub>16</sub> "



## KIT HERRAMIENTAS TRABAJO COLAS GEAR CASE TOOL KIT KIT ATTREZZATURA PER LAVORAZIONI NEI PIEDI

Ref.	R.O. OEM
RM91-31229A7	91-31229A7

Kit de montaje y desmontaje de los retenes y cojinetes de las colas Alpha, Alpha Gene II y Bravo.

Removes and installs bearings in MC-I, R-MR, Alpha One, Alpha One Gen Two and Bravo.

Permette di smonare, cuscinetti, paraoli in tutti i piedi Meecruiser, Alpha, Alpha Gene II e Bravo.

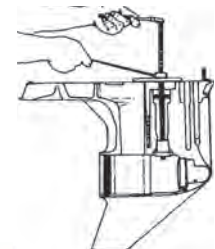

**LLAVES PARA ELEMENTOS DEL CAMBIO**  
**TOOLS FOR ELEMENTS TO DRIVESHAFT**  
**CHIAVI PER GLI ELEMENTI DEL CAMBIO**

Ref.	R.O. OEM
REC91-43579	91-43579

**Llave montaje y desmontaje casquillo sujeción tubo de agua.** Para todas las colas Bravo I, II y III.

**Drive shaft adapter.** For all Bravo I, II & III drive units.

**Chiave per smontare e montare la ghiera del tubo acqua.** Per piedi Bravo I, II e III.



Ref.	R.O. OEM
RM91-17275A1	91-17275A1

**Llave montaje retenes y casquillos eje cambio.** Para todas las colas Bravo I, II y III.

**Driveshaft shimming tool.** For all Bravo I, II & III drive units.

**Chiave per smontare paraolio e ghiera asse cambio.** Per i piedi Bravo I, II e III.



Ref.	R.O. OEM
REC91-31107T	91-31107T

**Llave tuerca varilla cambio.** Para montaje y desmontaje de las tuercas de la varilla cambio en las colas MC-I, R-MR, Alpha One.

**Shift shaft bushing tool.** Removes and installs the shift shaft bushing in the gear case of MC-I, R-MR, and Alpha One, drive units.

**Chiave dado asticella cambio.** Per i piedi MC-I, R-MR, Alpha One.



Ref.	R.O. OEM
REC91-56775T	91-56775T

**Llave estriado eje.** Da una superficie de llave para girar el eje de cambio en las colas MC-I, R-MR, Alpha One y Alpha One Gen II

**Drive shaft adapter.** Provides a wrench surface to turn the drive shaft on MC-I; R-MR; Alpha One; and Alpha One, Gen Two drive units.

**Chiave asse a millerighe.** Permette di avere una superficie per poter girare l'asse del cambio nei piedi MC-I, R-MR, Alpha One e Alpha One Gen II.



Ref.	R.O. OEM
RM91-17273	91-17273

**Llave montaje casquillos eje cambio.** Para todas las colas Bravo I, II y III

**Bushing removal tool.** For all Bravo drive units

**Chiave per montare ghiera asse cambio.** Per tutti i piedi Bravo I, II e III.



Ref.	R.O. OEM
RM91-17302	91-17302

**Llave extractora eje cambio.** Para todas las colas Bravo I, II y III.

**Shift handle tool.** For all Bravo drive units.

**Chiave estrattore asse cambio.** Per tutti i piedi Bravo I, II e III.



Ref.	R.O. OEM
REC91-12037	91-12037

**LLave cable cambio.** Para montaje y desmontaje de los cables de cambio en las colas MC-I, R-MR, Alpha One, Gene II.

**Shift cable tool.** Installs and removes drive shaft bearing retainer on MC-1, R-MR, Blackhawk, all Bravo, and all Alpha drive units.

**Chiave cavo cambio.** Per installare e smontare i cavi cambio nei piedi MC-I, R-MR, Alpha One, Gene II.

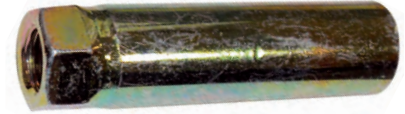

**EXTRACTOR PULLER ROD**  
**ESTRATTORE**

Ref.	R.O. OEM
REC91-31229	91-31229

Para utilizar con las herramientas REC91-43579 y REC91-36569T para instalar y desmontar el cojinete

Used with No. REC91-43579 & REC91-36569T tools to install & remove pinion bearing.

Per utilizzare con l'attrezzo REC91-43579 e REC91-36569T per installare e smontare i cuscinetti



**CENTRADOR MOTOR**  
**ENGINE ALIGNMENT TOOL**  
**CENTRATORE MOTORE**

Ref.	R.O. OEM
REC91-805475A1	91-805475A1

Centra el motor y la cola durante la instalación

Aligns engine and drive unit during installation.

Centra il motore con il piede durante l'installazione



**LLAVE ESTRIADO EJE**  
**PROP SHAFT ADAPTOR**  
**CHIAVE ASSE A MILLERIGHE**

Ref.	R.O. OEM
REC91-61077T	91-61077T

Da una superficie de llave para girar el eje de la hélice en las colas MC-I, R-MR, TRS, Alpha One y Gene II y Bravo I

Provides a wrench surface to turn the propeller shaft on MC-I; R-MR; Alpha One; Alpha One, Gen Two; Bravo One; and TRS drive units.

Permette di avere una superficie per poter girare l'asse nei piedi MC-I, R-MR, TRS, Alpha One e Gene II e Bravo I.



**LLAVES PARA FUELLES**  
**TOOL TO TRANSON BELLOWS**  
**ATTREZZO PER TRANSON**

Ref.	R.O. OEM
REC91-818162	91-818162

Transon Gen II y Bravo.



**LLAVE TUERCA DIABOLO**  
**BEARING CARRIER RETAINER**  
**WRENCH**  
**CHIAVE POGNONE**

Ref.	R.O. OEM
REC91-61069T	91-61069T

Instala y desinstala las tuercas del diablo en las colas MC-I, R-MR, TRS, Alpha One y Gene II y Bravo I y II  
Removes and installs bearing carrier retainer nuts on Bravo One and Two; MC-I; R-MR; and Alpha One, Gen. Two; and TRS; drive units.  
Permette di installare e smontare il diavolo nei MC-I, R-MR, TRS, Alpha One y Gene II e Bravo I e II.



**LLAVE TUERCA EJE VERTICAL**  
**DRIVE SHAFT BEARING**  
**RETAINER WRENCH**  
**CHIAVE PER DADO ASSE VERTICALE**

Ref.	R.O. OEM
REC91-43506T	91-43506T

Para montaje y desmontaje del retenedor y cojinete superior en colas Alpha y fuerabordas.  
Removes and installs threaded bearing retainer on Alpha stern drives.  
Per montare e smontare il fermo ed il cuscinetto superiore nei piedi Alpha e fuoribordo.



Ref.	R.O. OEM
REC91-61067A04	91-61067A04

Incluye un adaptador eje REC91-56775T. Sostiene la tuerca del piñón cuando se está sacando el piñón y el eje en las colas MC-I, R-MR, Alpha One.  
Holds pinion nut when removing pinion gear and drive shaft on MC-I, R-MR, and Alpha One drive units. Comes with one REC91-56775T drive shaft adaptor.  
Include un adattatore per asse REC91-56775T. Per i piedi MC-I, R-MR, Alpha One.



**LLAVE TUERCA CARDAN**  
**BEARING RETAINER WRENCH**  
**CHIAVE CARDANO**

Ref.	R.O. OEM
REC91-17256	91-17256

Para montaje y desmontaje de la tuerca del cardan en todas las colas MC-I, R-MR, Blackhawk, Alpha y Bravo.  
Installs and removes drive shaft bearing retainer on MC-1, R-MR, Blackhawk, all Bravo, and all Alpha drive units.  
Per installare e smontare il cardano nei piedi MC-I, R-MR, Blackhawk, Alpha e Bravo.



Ref.	R.O. OEM
REC90490	91-17257T 91-8053741

Para montaje y desmontaje de la tuerca del cardan en las colas Bravo II y Bravo III.  
Installs and removes bearing carrier retainer nuts on Bravo II & Bravo III sterndrive units.  
Per smontare il cardano nei piedi Bravo II e III.



**LLAVE TORNILLO LATERAL TRANSOM**  
**HINGE PIN TOOL**  
**CHIAVE VITE LATERALE TRANSOM**

Ref.	R.O. OEM
REC91-78310	91-78310

Instala y desinstala los tornillos laterales de las colas.  
Removes and installs hinge pins from drive units.  
Per tutti i piedi Mercuriser.



**LLAVE GALGADO PIÑONES**  
**PINION GEAR SHIMMING TOOL**  
**CHIAVE INSTALLAZIONE PIGNONI**

Ref.	R.O. OEM
REC91-56048001	91-56048001

Mide la altura del piñón en las colas MC-I, R-MR, Alpha One y Gene II  
Measures pinion height of MC-I; R-MR; Alpha One; and Alpha One, Gen Two drive units.  
Misura l'altezza dei pignoni nei piedi MC-I, R-MR, Alpha One e Gene II.



Ref.	R.O. OEM
REC91-60523	91-60523
REC91-60526T	91-60526T

Mide la distancia de los piñones en la parte superior en las colas MC-I, R-MR, Alpha One y Gene II.  
Measures upper drive gear clearance on MC-I; R-MR; Alpha One; and Alpha one, Gen Two drive units.  
Misura la distanza dei pignoni della parte alta nei piedi MC-I, R-MR, Alpha One Gene II.



REC91-60523



REC91-60526T

**PISTOLA DE ACEITE**  
**BOTTLE GREASE PUMP**  
**PISTOLA OLIO**

Ref.	R.O. OEM
REC55005	91-850730Q01 91-8M0072133

Pistola para acoplar en los envases de botella de 1L LUB11552 y LUB11564U12. Se suministra con kit de adaptación con válvula antirretorno.  
Lower unit quart pump. Complete with metal threaded filler fitting.  
Pistola da usare con le bottiglie da 1L LUB11552 e LUB11564U12. Si vende con kit di accoppiamento con valvola anti-ritorno.



# IMPULSORES Y KITS REPARACIÓN BOMBA IMPELLERS & WATER PUMP SERVICE KIT GIRANTI E KIT RICAMBI POMPA ACQUA

## IMPULSORES IMPELLERS GIRANTI

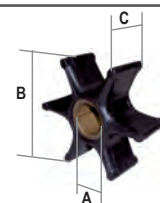

	MOTORES ENGINES MOTORI	R.O. OEM	SHERWOOD	CEF	JOHNSON	JABSCO	RECMAR	MEDIDAS (mm) MEASURES (mm) MISURE (mm)		
								A	B	C
1	Para motores CUMMINS con bomba SHERWOOD G2601 y G2603X. Impeller for Sherwood pump G2601 & 2603X. Per motori Cummins con pompa Sherwood G2601 e G2603X.	3972366	SHE26000K	CEF500183G				20	94,5	79,8
2	Diesel 7.3 l	47-853126 3349198 3916720	SHE15000K	CEF500167			REC15000K	16	65	51,2
3	MC-1/R/MR/Alpha One	47-89984T4		CEF500313G			REC47-89984T4	22,3	60	33,8
4	ALPHA GENE II	47-43026Q02		CEF500301			REC47-43026Q02	22,4	89	32,5
5	530DTA, 636DTA, D219, D183, D281, D4.2L	47-801332602		CEF500106GT	JOH09-1028B		REC3841697	14,29	65	50,2
6	BRAVO. Motores de Inyección. BRAVO. Injection engines BRAVO. Motori di iniezione	47-862232A2 47-8M0104229		CEF500159G			REC47-862232A2	11,4	66,5	50,6
7	HINO Diesel	47-809866T 47-831311350		CEF500161			REC47-809866T	14,29	65	68,2
8	D254, D3.6L, D4.2L	47-816814T		CEF500177GT		JAB17018-0001	REC3593573	14,29	65,2	75,65
9	BRAVO	47-59362Q01		CEF500109			REC47-59362Q01	16,85	66,5	50,6



1

Núcleo estriado  
Fluted core.  
Nucleo scanalato.



2

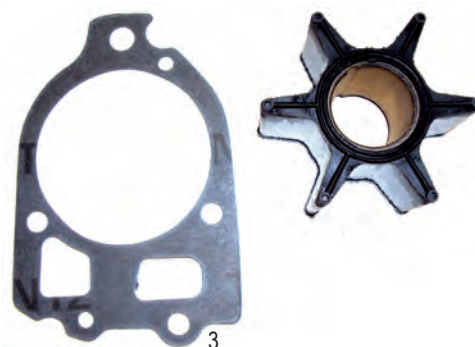

3



4



5



6



7



8



9



**KITS REPARACIÓN BOMBA AGUA (1 / R / MR/ ALPHA ONE)  
WATER PUMP SERVICE KITS (1 / R / MR/ ALPHA ONE)  
KIT RICAMBI POMPA ACQUA (1 / R / MR/ ALPHA ONE)**

Ref.	R.O. OEM
REC46-44292Q03	46-44292Q03

**MOTORES / ENGINES / MOTORI**  
MR1 Alpha one (1984-90)



Ref.	R.O. OEM
REC46-48748T1	46-48748A1 2495186 2763441

**MOTORES / ENGINES / MOTORI**  
MR1 Alpha one (1967-69)



Ref.	R.O. OEM
REC12120	46-96148A8

**MOTORES / ENGINES / MOTORI**  
MR / ALPHA I (6225577+)

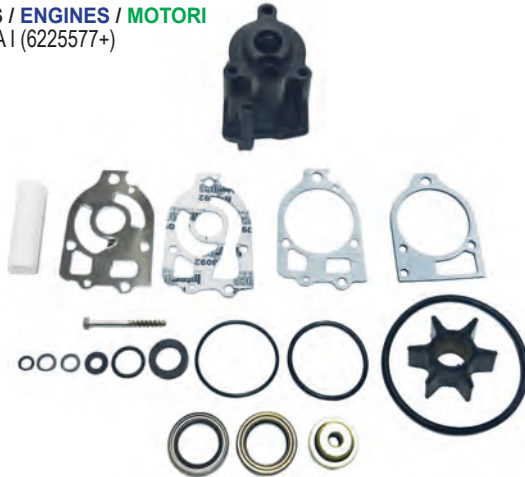

Ref.	R.O. OEM
REC46-48748T1	46-48748T1

**MOTORES / ENGINES / MOTORI**  
MC-1 (1969+)

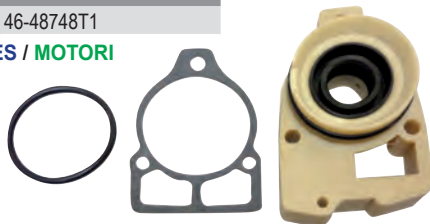

Ref.	R.O. OEM
REC12110	

**MOTORES / ENGINES / MOTORI**  
Excepto / Except / Eccetto MR/ALPHA ONE  
MC-1 (2791957-6225576)  
(1970-83)

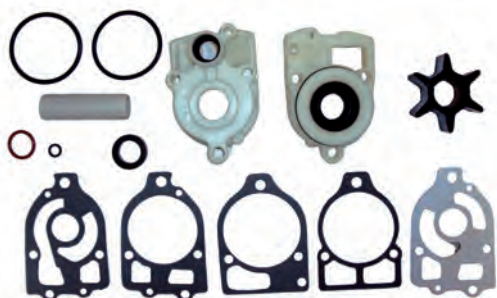

Ref.	R.O. OEM
RECMC00002	

**MOTORES / ENGINES / MOTORI**  
MR & ALPHA ONE (622557+)  
Kit completo / Full kit / Kit completo



Ref.	R.O. OEM
RECMC00001	

**MOTORES / ENGINES / MOTORI**  
MC-1 (2663442-6225576)  
Kit completo / Full kit / Kit completo

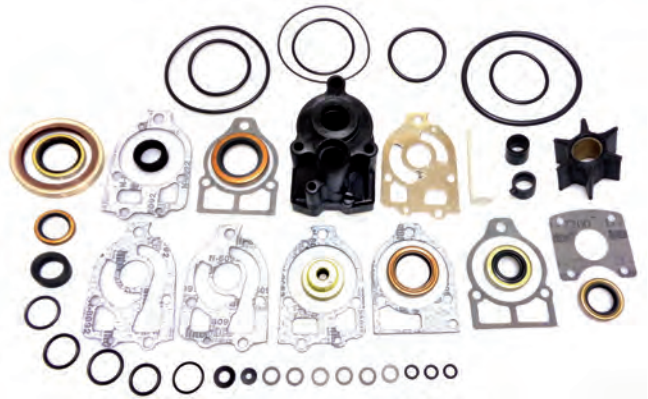

Ref.	R.O. OEM
REC46-64141A11	46-64141A11

**MOTORES / ENGINES / MOTORI**  
MC-1 (2062141-2791956)



Ref.	R.O. OEM
REC46-96148A8	46-60367A1 46-96148A8 46-96148A5

Parte superior.  
Upper water pump housing.  
Parte superiore.  
MC-1 & ALPHA-ONE

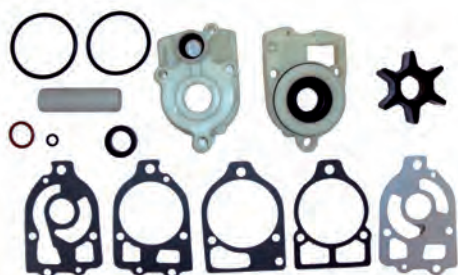

R.O. OEM			
324351	TAPA BOMBA	PUMP COVER	COPERCHIO POMPA
12-191833	JUNTA	GASKET	GUARNIZIONE
23-29804T	TUBO AGUA	WATER TUBE	TUBO ACQUA
25-30224Q	ARO	O-RING	ANELLO
25-30271	ARANDELA	WASHER	RONDELLA
25-30613	ARO	O-RING	ANELLO
25-33145	ARO	O-RING	ANELLO
25-90011	ARO	O-RING	ANELLO
26-455771	RETÉN	SEAL	TENUTA
27-32438	JUNTA	GASKET	GUARNIZIONE
27-426311	JUNTA	GASKET	GUARNIZIONE
27-856081	JUNTA	GASKET	GUARNIZIONE
27-856091	JUNTA	GASKET	GUARNIZIONE
27-856704	JUNTA	GASKET	GUARNIZIONE
48-96148T1	CUERPO BOMBA	PUMP HOUSING	CORPO POMPA
47-89984T4	IMPULSOR	IMPELLER	GIRANTE

Ref.	R.O. OEM
REC47-89984Q5	47-89984Q5

MOTORES / ENGINES / MOTORI  
MC-1 & ALPHA ONE

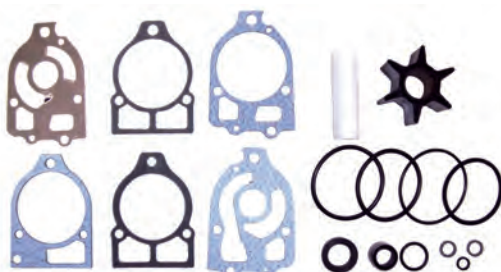

R.O. OEM			
324351	TAPA BOMBA	PUMP COVER	COPERCHIO POMPA
12-191833	JUNTA	GASKET	GUARNIZIONE
23-29804T	TUBO AGUA	WATER TUBE	TUBO ACQUA
25-30224Q	ARO	O-RING	ANELLO
25-30271	ARANDELA	WASHER	RONDELLA
25-30613	ARO	O-RING	ANELLO
25-33145	ARO	O-RING	ANELLO
25-90011	ARO	O-RING	ANELLO
26-455771	RETÉN	SEAL	TENUTA
27-32438	JUNTA	GASKET	GUARNIZIONE
27-426311	JUNTA	GASKET	GUARNIZIONE
27-856081	JUNTA	GASKET	GUARNIZIONE
27-856091	JUNTA	GASKET	GUARNIZIONE
27-856704	JUNTA	GASKET	GUARNIZIONE
47-89984T4	IMPULSOR	IMPELLER	GIRANTE
26-38970	ACOPLE GOMA	COUPLING	ACCOPIAMENTO
25-38099	ARO	O-RING	ANELLO
25-26722	ARO	O-RING	ANELLO

**KITS REPARACIÓN BOMBA AGUA (ALPHA ONE GEN II)**  
**WATER PUMP SERVICE KITS (ALPHA ONE GEN II)**  
**KIT RICAMBI POMPA ACQUA (ALPHA ONE GEN II)**

Ref.	R.O. OEM
REC47-43026Q06	47-43026Q06



R.O. OEM				Cantidad Quanty Quantità
47-43026Q2	IMPULSOR	IMPELLER	GIRANTE	1
8172761	PLACA	WEAR PLATE	PIASTRA	1
27-8172771	JUNTA	GASKET	GUARNIZIONE	1
27-430331	JUNTA	GASKET	GUARNIZIONE	1
12-191833	JUNTA	GASKET	GUARNIZIONE	2
28-8M0032833	CHAVETA	KEY	CHIAVE	1
26-816575A2	RETÉN	FACE SEAL	TENUTA	1
816597A1	ACOPPLAMIENTO	COUPLIN	ACCOPIAMENTO	1

Ref.	R.O. OEM
RECMC00004	47-43026Q06

MOTORES / ENGINES / MOTORI  
(1991+)



R.O. OEM				Cantidad Quanty Quantità
8172761	PLACA	WEAR PLATE	PIASTRA	1
27-430331	JUNTA	GASKET	GUARNIZIONE	1
47-43026Q02	IMPULSOR	IMPELLER	GIRANTE	1
807929A1	RETÉN	PUMP SEAL CARRIER	TENUTA	1
27-8172772	JUNTA	GASKET	GUARNIZIONE	1

Ref.	R.O. OEM
REC817275Q05	817275Q05

**MOTORES / ENGINES / MOTORI**  
Serie / Serial / Serie D469859+



R.O. OEM				Cantidad Qty Quantità
46-96148T1	TAPA BOMBA	WATER PUMP HOUSING	COPERCHIO POMPA	1
27-430331	JUNTA	GASKET	GUARNIZIONE	1
47-43026Q02	IMPULSOR	IMPELLER	GIRANTE	1
807929A1	RETÉN	SEAL	TENUTA	1
27-8172772	JUNTA	GASKET	GUARNIZIONE	1
8172761	PLACA	WEAR PLATE	PIASTRA	1

**KITS REPARACIÓN BOMBA AGUA (BRAVO I, II, III)  
WATER PUMP SERVICE KITS (BRAVO I, II, III)  
KIT RICAMBI POMPA ACQUA (BRAVO I, II, III)**

Ref.	R.O. OEM
REC47-59362Q08	47-59362Q08

Bombas con 2 piezas de plástico.  
2 pcs. plastic bodies Sea Water pump  
Pompa in 2 pz in plastica.



Ref.	R.O. OEM
REC59503	59503

Tapa bomba  
Wear plate  
Piastra



Ref.	R.O. OEM
REC47-59362T6	47-59362T6

Para bombas de una pieza.  
Fits one piece pump.  
Per pompe in bronzo in pz.



Ref.	R.O. OEM
REC46-807151A14	807151A14

Bombas con 1 cuerpo de plástico.  
1 piece plastic body pump  
Pompa con 1 corpo in plastica



Ref.	R.O. OEM
SHE15979	808145T

**MOTORES / ENGINES / MOTORI**  
Diesel 7.3L

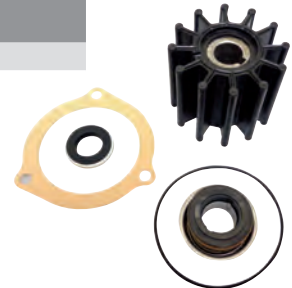

Ref.	R.O. OEM
REC47-59362T5	47-59362T5

Para modelos de bomba de bronce de una  
pieza Mercruiser (-1982).  
Fits Mercruiser (-1982) with  
one piece brass pump.  
Per pompe in bronzo  
in 1 pz (1982)



Ref.	R.O. OEM
REC47-59362A4	47-59362A4

Para bomba Mercruiser de dos piezas.  
Fits Mercruiser two piece pump.  
Per pompe in 2 pz.



## DESPIECE BOMBA AGUA WATER PUMP ASSEMBLY ESPLOSO POMPA ACQUA

Nº	REF.	R.O. OEM	Descripción	Description	Descrizione	Cantidad Quantity Quantità
2	REC12-20084	12-20084	ARANDELA	WASHER	RONDELLA	5
4	REC27-8052151	27-8052151	JUNTA	GASKET	GUARNIZIONE	1
5	REC94916	94916	TAPA	WEAR PLATE	COPERCHIO	1
6	REC27-94914	27-94914	JUNTA	GASKET	GUARNIZIONE	1
7	REC47-59362Q01	47-59362Q01	IMPULSOR	IMPELLER	GIRANTE	1
8	REC19-59504	19-59504	TAPÓN	PLUG	TAPPO	1
9	REC25-33465	25-33465	ARANDELA	O-RING	RONDELLA	1
10	REC46-807151A14	46-807151A14	CUERPO BOMBA	PUMP HOUSING	CORPO POMPA	1
12	REC94576	94576	TAPA	WEAR PLATE	PIASTRA	1
13	REC25-94288	25-94288	ARO TÓRICO	O-RING	TENUTA	1
14	REC26-90562	26-90562	RETÉN	OIL SEAL	PARAOLIO	2
15	REC46-94913A5	46-94913A5	CUERPO COJINETE	BEARING HOUSING	CORPO CUSCINETTO	1
16	REC30-72961	30-72961	COJINETE	BEARING	CUSCINETTO	2
17	REC59501A1	59501A1	EJE	SHAFT	ASSE	1
18	REC53-23720	53-23720	ARO RETENEDOR	RETAINER RING	TENUTA	1
19	REC26-72785	26-72785	RETÉN ACEITE	OIL SEAL	PARAOLIO	1
20	REC92995-08600	12-36001	ARANDELA	WASHER	RONDELLA	5
21	REC861579	861579	POLEA	PULLEY	PULEGGIA	1

**BOMBA CON 2 PIEZAS DE PLÁSTICO**  
**2 PCS. PLASTIC PUMP**  
**POMPA CON 2 PZ IN PLASTICA**

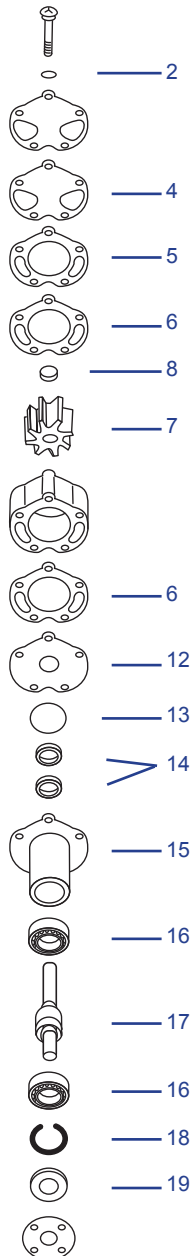

**BOMBA CON 1 PIEZA DE PLÁSTICO**  
**1 PC. PLASTIC PUMP**  
**POMPA CON 1 PZ IN PLASTICA**

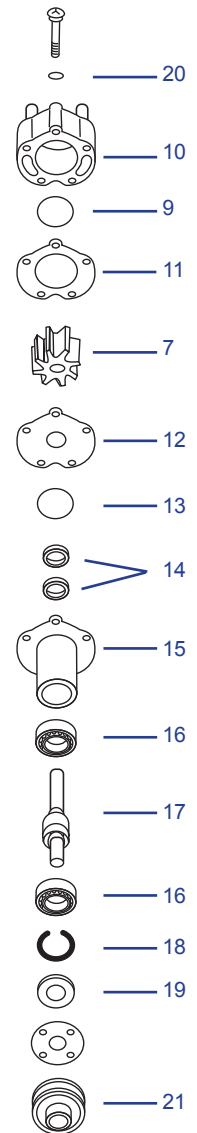

# ÁNODOS ANODES ANODOS

ZN	R.O. OEM R.O.	KG (KG)	MOTORES ENGINES MOTORI
TEN00800	1301339	0,48	50 HP



ZN	R.O. OEM R.O.	KG (KG)	MOTORES ENGINES MOTORI
TEN00801	34127	0,60	80 - 140 HP



ZN	R.O. OEM R.O.	KG (KG)	MOTORES ENGINES MOTORI
TEN00802	94286	0,27	25 HP



ZN	R.O. OEM R.O.	KG (KG)	MOTORES ENGINES MOTORI
TEN00803	47820	0,31	20 HP



ZN	R.O. OEM R.O.	KG (KG)	MOTORES ENGINES MOTORI
TEN00804	46399	0,40	50 - 140 HP



ZN	R.O. OEM R.O.	KG (KG)	MOTORES ENGINES MOTORI
TEN00806	43994	0,90	ALPHA GEN II, BRAVO



ZN	R.O. OEM R.O.	KG (KG)	MOTORES ENGINES MOTORI
TEN00806BIS	821521	0,89	



ZN	R.O. OEM R.O.	KG (KG)	MOTORES ENGINES MOTORI
TEN00807	55989	0,10	ALPHA ONE, BRAVO I



ZN	R.O. OEM R.O.	KG (KG)	MOTORES ENGINES MOTORI
TEN00814	821629	0,70	ALPHA ONE, ALPHA GEN II



ZN	R.O. OEM R.O.	KG (KG)	MOTORES ENGINES MOTORI
TEN00815	821630	0,98	BRAVO I, II, III



ZN	R.O. OEM R.O.	KG (KG)	MOTORES ENGINES MOTORI
TEN00817	806189	0,12	PISTON ALPHA



ZN	R.O. OEM R.O.	KG (KG)	MOTORES ENGINES MOTORI
TEN00818	806190	0,34	PISTON BRAVO



ZN	R.O. OEM R.O.	KG (KG)	MOTORES ENGINES MOTORI
TEN00819	806105	0,23	ALPHA ONE, ALPHA GEN II



ZN	R.O. OEM R.O.	KG (kg)	MOTORES ENGINES MOTORI
TEN00820	76214-5	0,34	ALPHA

**TECNOSEAL**  
save your dreams



ZN	R.O. OEM R.O.	Ø (mm)	KG (kg)	MOTORES ENGINES MOTORI
TEN00823	823912	20	0,01	
TEN00824	823913	24	0,02	

**TECNOSEAL**  
save your dreams



ZN	R.O. OEM R.O.	KG (kg)	MOTORES ENGINES MOTORI
TEN00826	76214	0,31	VERADO - BRAVO

**TECNOSEAL**  
save your dreams



ZN	R.O. OEM R.O.	KG (kg)	MOTORES ENGINES MOTORI
TEN00827	17264	0,51	FORMULA 60 HP

**TECNOSEAL**  
save your dreams



ZN	R.O. OEM R.O.	KG (kg)	MOTORES ENGINES MOTORI
TEN00828	806188	0,17	BRAVO I, III

**TECNOSEAL**  
save your dreams



ZN	R.O. OEM R.O.	KG (kg)	MOTORES ENGINES MOTORI
TEN00835	76214-4	0,26	

**TECNOSEAL**  
save your dreams



ZN	R.O. OEM R.O.	KG (kg)	MOTORES ENGINES MOTORI
TEN00836	865182	0,52	BRAVO III

**TECNOSEAL**  
save your dreams



ZN	R.O. OEM R.O.	KG (kg)	MOTORES ENGINES MOTORI
TEN00839	853762	0,15	

**TECNOSEAL**  
save your dreams



## KITS

ZN	R.O. OEM R.O.	KG (kg)	MOTORES ENGINES MOTORI
TENKITALPHAONE/1	8887562Q02	1,83	MR, ALPHA ONE (1984-1990)

**TECNOSEAL**  
save your dreams



ZN	R.O. OEM R.O.	KG (kg)	MOTORES ENGINES MOTORI
TENKITALPHAONE/2	888756Q01 888756Q03	2,52	ALPHA ONE GEN II

**TECNOSEAL**  
save your dreams



ZN	R.O. OEM R.O.	KG (kg)	MOTORES ENGINES MOTORI
TENKITBRAVOI	888758Q01	2,34	BRAVOI

**TECNOSEAL**  
save your dreams



ZN	R.O. OEM R.O.	KG (kg)	MOTORES ENGINES MOTORI
TENKITBRAVOII-III	888761Q01	2,13	BRAVOII & III

**TECNOSEAL**  
save your dreams



ZN	R.O. OEM R.O.	KG (kg)	MOTORES ENGINES MOTORI
TENKITBRAVOIII-04	888761Q02	3	BRAVOIII (2004+)

**TECNOSEAL**  
save your dreams



ZN	KG (KG)	AL	KG (KG)	R.O. OEM R.O.	MOTORES ENGINES MOTORI
CMX-1	0,136	CMX-1A	0,13	85538 823341	ALPHA I



ZN	KG (KG)	AL	KG (KG)	R.O. OEM R.O.	MOTORES ENGINES MOTORI
CM762144	0,31	CM762144A	0,13	76214-4	BRAVO III (2003+)



ZN	KG (KG)	AL	KG (KG)	R.O. OEM R.O.	MOTORES ENGINES MOTORI
CM762145	0,33	CM762145A	0,13	76214A2 76214Q5	ALPHA ONE GEN II BRAVO III (-2003)



ZN	KG (KG)	R.O. OEM R.O.	MOTORES ENGINES MOTORI
CM76214Q5	0,33	76214Q5	BRAVO 4 225-250 HP



ZN	KG (KG)	AL	KG (KG)	R.O. OEM R.O.	MOTORES ENGINES MOTORI
CM31640	0,55	CM31640A	0,13	31640A4	ALPHA ONE



ZN	KG (KG)	AL	KG (KG)	R.O. OEM R.O.	MOTORES ENGINES MOTORI
CM46399	0,36	CM46399A	0,14	46399A1 822777Q1	ALPHA ONE GEN II



ZN	KG (KG)	AL	KG (KG)	R.O. OEM R.O.	MOTORES ENGINES MOTORI
CM34127	0,59	CM34127A	0,22	34127T2	



ZN	KG (KG)	AL	KG (KG)	R.O. OEM R.O.	MOTORES ENGINES MOTORI
CM806189	0,10	CM806189A	0,04	806189Q1	GEN II



ZN	KG (KG)	AL	KG (KG)	R.O. OEM R.O.	MOTORES ENGINES MOTORI
CM806105	0,23	CM806105A	0,09	806188A1	ALPHA ONE, GEN II



ZN	KG (KG)	AL	KG (KG)	R.O. OEM R.O.	MOTORES ENGINES MOTORI
CM55989	0,11	CM55989A	0,09	55989A9 55989Q9	ALPHA ONE, GEN II



ZN	KG (KG)	AL	KG (KG)	R.O. OEM R.O.	MOTORES ENGINES MOTORI
CM821629	0,78	CM821629A	0,30	821629Q1	ALPHA ONE GEN II



ZN	KG (KG)	AL	KG (KG)	R.O. OEM R.O.	MOTORES ENGINES MOTORI
CM34762	0,24	CM34762A	0,09	34762A1	



ZN	KG (KG)	AL	KG (KG)	R.O. OEM R.O.	MOTORES ENGINES MOTORI
CM806188	0,15	CM806188A	0,06	806188A1	BRAVO



ZN	KG (KG)	AL	KG (KG)	R.O. OEM R.O.	MOTORES ENGINES MOTORI
CM806190	0,35	CM806190A	0,14	806190Q1	BRAVO



ZN	KG (KG)	AL	KG (KG)	R.O. OEM R.O.	MOTORES ENGINES MOTORI
CM821630	1,00	CM821630A	0,39	821630A1/Q1	BRAVO



ZN	KG (KG)	AL	KG (KG)	R.O. OEM R.O.	MOTORES ENGINES MOTORI
CM43994	0,95			43994A2 821631A1	Antiguos old vecchio



ZN	KG (KG)	AL	KG (KG)	R.O. OEM R.O.	MOTORES ENGINES MOTORI
CM821631	0,89	CM821631A	0,35	43994A2 821631A1	Modernos New style Moderno



**KITS**

ZN (KIT)	KG (KG)	ZN (ANODO / ANODE / ANODO)	KG (KG)	R.O. OEM R.O.	MOTORES ENGINES MOTORI
CMCC	0,93	CMC			ALPHA I , MR



ZN	KG (KG)	AL	KG (KG)	R.O. OEM R.O.	MOTORES ENGINES MOTORI
CMPNCF16Z	0,93	CMPNCF16A	0,54		ALPHA I , BRAVO I



ZN	KG (KG)	AL	KG (KG)	R.O. OEM R.O.	MOTORES ENGINES MOTORI
CMPNEZF14A	1,14		0,65		BRAVO II



ZN	KG (KG)	AL	KG (KG)	R.O. OEM R.O.	MOTORES ENGINES MOTORI
CMPNDAF14UNS	0,93	CMPNDAF14UNSA	0,54		BRAVO III (-2003)



ZN	KG (KG)	AL	KG (KG)	R.O. OEM R.O.	TIPO TIPO	MOTORES ENGINES MOTORI
CMPNAZ	0,09	CMPNAA	0,03		A	BRAVO
CMPNBZ	0,23	CMPNBA	0,09		B	
CMC	0,45	CMPNCA	0,19		C	
CMPNDZ	0,68	CMPNDA	0,29		C	



ZN	KG (KG)	AL	KG (KG)	R.O. OEM R.O.	MOTORES ENGINES MOTORI
CM865182CZ	0,51	CM865182CA	0,42		BRAVO III (2004+)



AL	MG	R.O. OEM R.O.	MOTORES ENGINES MOTORI
CMBRAVO3KITA	CMBRAVO3KITM	888761Q02	BRAVO III (2004+)



AL	MG	R.O. OEM R.O.	MOTORES ENGINES MOTORI
CMALPHAGEN1KITA	CMALPHAGEN1KITM	888756Q02	MR, ALPHA ONE (1984-90)



AL	MG	R.O. OEM R.O.	MOTORES ENGINES MOTORI
CMALPHA KITA	CMALPHA KITM	888756Q01 888756Q03	ALPHA ONE GEN II



AL	MG	R.O. OEM R.O.	MOTORES ENGINES MOTORI
CMBRAVO1KITA	CMBRAVO1KITM	888758Q01	BRAVO I



AL	MG	R.O. OEM R.O.	MOTORES ENGINES MOTORI
CMBRAVO2Y3KITA	CMBRAVO2Y3KITM	888761Q01	BRAVO II, BRAVO III





# TRANSOM

## TRANSOM Y PISTÓN DIRECCIÓN GIMBAL HOUSING & POWER STEERING CYLINDER KIT TRANSOME E PISTONE STERZO ALPHA ONE GEN I & II

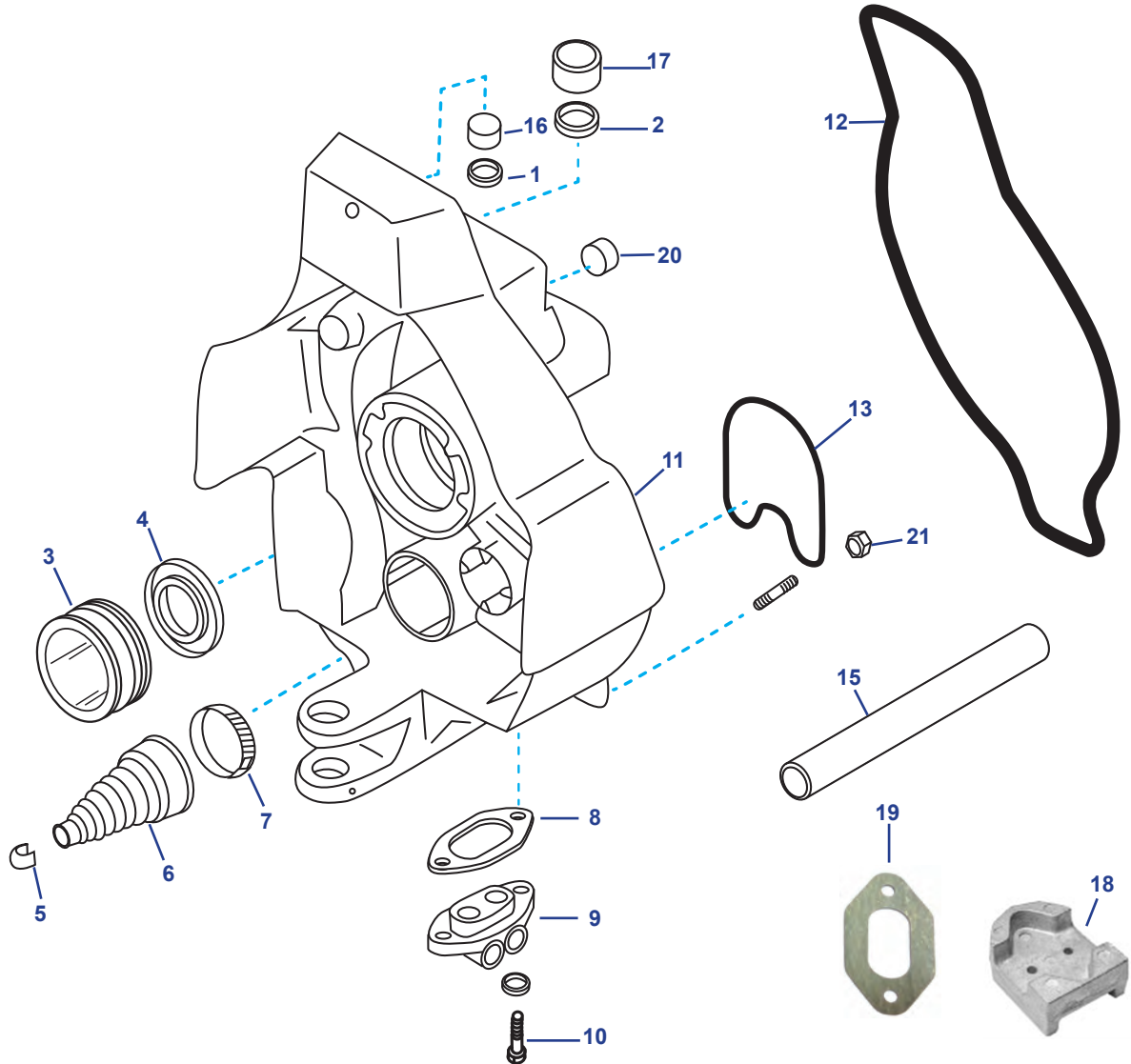

Ref.	R.O. OEM
REC22-88847A1	22-88847A1

Kit tuerca y tapones  
Plug kit  
Kit dado tappo

Ref.	R.O. OEM
REC27-47644-1	27-47644-1

**CONECTOR HIDRÁULICO**  
**HYDRAULIC CONNECTOR**  
**CONNETTORE IDRÁULICO**

**MOTORES / ENGINES / MOTORI**  
ALPHA ONE S (1986-89)  
SSM II / III / IV / V (1982-95)  
Para conector / for connector / per connettore: 47347

Ref.	R.O. OEM
REC30-879194A01	30-879194A01

Cojinete para todos los transom Alpha One Gen I - Gen II  
Gimbal Bearing assy. for all transom Alpha One Gen I - Gen II  
Cuscinetto per tutti i transom Alpha One Gen I - Gen II

Ref.	R.O. OEM
REC8M0080805	8M0080805

**NEW**

Kit conector Trim  
Trim connector kit  
Kit connettore Trim

Ref.	R.O. OEM
CM55989	55989Q9
CM55989A	AI
REC55989Q9	Kit AI

Ánodo TRANSOM  
Transom anode  
Anodo transom

Nº	Ref.	R.O. OEM	Descripción	Description	Descrizione
1	REC26-54925	26-54925	RETÉN (Alpha one)	SEAL (Alpha one)	PARAOLIO (Alpha one)
2	REC26-55682	26-55682	RETÉN (Alpha one)	SEAL (Alpha one)	PARAOLIO (Alpha one)
2	REC26-8M2005029	26-416071	RETÉN (Alpha one II Gen)	SEAL (Alpha one II Gen)	PARAOLIO (Alpha one II Gen)
3	REC30-879194A01	30-879194A01	COJINETE TRANSOM ALPHA ONE GEN I - GEN II	GIMBAL BEARING FOR ALL TRANSOM ALPHA ONE GEN I - GEN II	CUSCINETTO TRANSOM ALPHA ONE GEN I - GEN II
4	REC26-88416	26-88416	RETÉN	SEAL	PARAOLIO
5	REC54-38863	54-38863	ABRAZADERA	CLAMP	FASCETTA
6	REC74639Q02	74639Q02	FUELLE CABLE CAMBIO	SHIFT BELLOW	CAVO CAMBIO A SOFFIETTO
7	REC54-815504320	54-815504320	ABRAZADERA	CLAMP	FASCETTITA
8	REC27-988231	27-988231	JUNTA	GASKET	GUARNIZIONE
9	REC8M0080805	8M0080805	KIT CONECTOR	TRIM CONNECTOR KIT	KIT CONNETTORE TRIM,
10	REC10-28668	10-28636	TORNILLO	SCREW	VITE
11	RM94989A6	94989A6	TRANSOM GEN I (EJE CUADRADO / ESTRIADO)	GEN I TRANSOM (SQUARED FIXATION SHAFT)	TRANSOM GEN I (ASSE QUADRATO)
11	RM42260A6	42260A6	TRANSOM GEN I (EJE CUADRADO / CUADRADO)	GEN I TRANSOM (SQUARED FIXATION SHAFT)	TRANSOM GEN I (ASSE QUADRATO)
11	RM43881A14	8M0062568	TRANSOM (1991+) GEN II	GIMBAL HOUSING ASSY. (1991+)	TRANSOM (1991+) GEN II
12	REC43713	43713	JUNTA TRANSOM GEN II, BRAVO	BLACKHAWK TRANSOM SEAL GEN II, BRAVO	GUARNIZIONE TRANSOM GEN II, BRAVO
12	REC65533A1	65533A1	JUNTA TRANSOM MC1/R/ALPHA ONE	TRANSOM SEAL MC1/R/ALPHA ONE	GUARNIZIONE TRANSOM MC1/R/ALPHA ONE
13	REC41802	41802	RETÉN TRANSOM	SEAL	TENUTA
15	REC32-4172533	32-4172533	TUBO AGUA Ø 3/4"	Ø 3/4" WATER HOSE	Ø 3/4" TUBO ACQUA
15	REC32-32461	32-32461	TUBO AGUA Ø 5/8"	Ø 5/8" WATER HOSE	Ø 5/8" TUBO ACQUA
16	RM23-98356	23-98356	CASQUILLO SUPERIOR	UPPER BUSHING	BOCCOLA SUPERIORE
17	RM23-983571	23-983571	CASQUILLO INFERIOR	LOWER BUSHING	BOCCOLA INFERIORE
18	CM821631	821631Q1	ÁNODO ZINC	ZINC ANODE	ANODO ZINCO
18	CM821631A	821631Q1	ÁNODO ALUMINIO	ALUMINIUM ANODE	ANODO ALLUMINIO
19	REC27-995061	27-995061	JUNTA	GASKET	GUARNIZIONE
20	REC22-73379	22-73379	TAPÓN (.250-18)	CAP (.250-18)	TAPPO (.250-18)
21	REC11-34933	11-34933	TUERCA	NUT	DADO

**TRANSOM COMPLETO  
TRANSOM ASSEMBLY  
TRANSOM COMPLETO**

**ALPHA ONE GEN I**

Ref.	R.O. OEM
TRANSONALPHAI	6-601000CP



**ALPHA ONE GEN II**

Ref.	R.O. OEM
TRANSONALPHA2G	6-6111002LP



**CAMPANA TRANSOM, CABLE CAMBIO Y BOMBA DIRECCIÓN  
TRANSOM PLATE, SHIFT CABLE & PUMP ASSY. POWER STEERING  
CAMPANA TRANSOM, CAVO CAMBIO E POMPA STERZO**

186

MERCURISER

Ref.	R.O. OEM
REC87-814281A5	87-814281A5

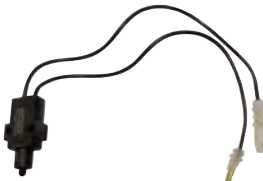

Microruptor  
Shift plate kit  
Microinterruttore  
3.0L, LX, 4.3L, LXL, 5.0L & 5.7, LX (1996+)

Ref.	R.O. OEM
RM8M0052936	87-8M0052936 87-808009A1 87-808009A3



Microruptor  
Shift plate kit  
Microinterruttore  
4.3MPI, 5.0LMPi, 350MAG MPI, MX, 6.2L MPI, 4.3, 5.0, 5.7L EFI, LX

Ref.	R.O. OEM
REC87-808009A2	87-808009A2 87-8M0052935



Microruptor  
Shift plate kit  
Microinterruttore  
4.3MPI, 5.0LMPi, 350MAG MPI, MX, 6.2L MPI

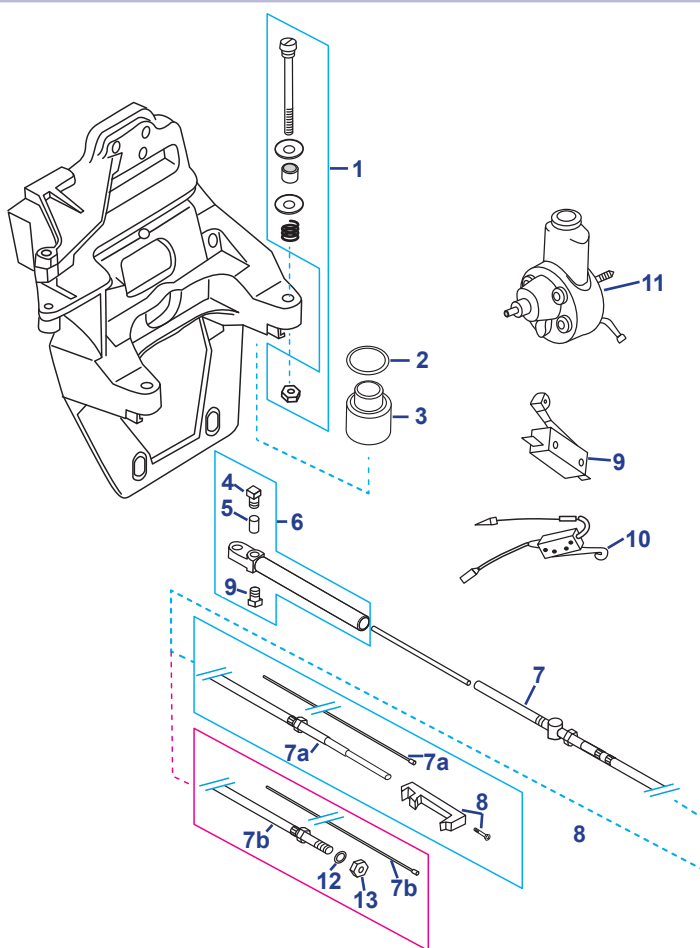

Ref.	R.O. OEM
REC10-31700	10-31700



Tornillo  
Screw  
Vite

Ref.	R.O. OEM
REC73873A1	73873A1



Polea "V" bomba servo  
P/S Pump Pulley  
Puleggia "V"

Ref.	R.O. OEM
REC861578	861578



Polea Serpentin  
P/S Pump Pulley  
Puleggia serpentina

Nº	Ref.	R.O. OEM	Descripción	Description	Descrizione
1	REC10-97934A1	10-97934A1	KIT MONTAJE SILENTBLOCK CAMPANA	MOTOR MOUNT BOLT KIT	KIT SILENTBLOCK CAMPANA
2	REC23-99322	23-99322	ESPACIADOR SILENTBLOCK	SILENTBLOCK SPACER	SILENTBLOCK DISTANZIALE
3	REC865329A02	865329A02	SILENTBLOCK MOTOR	MOTOR MOUNT SILENTBLOCK	SILENTBLOCK MOTORE
4	REC10-20518	10-20518	TORNILLO	BOLT	VITE
5	REC43436	43436	ANCLAJE	ANCHOR	SEDE
6	REC02644	43433 + 43436 + 10-20518	GUÍA CABLE CAMBIO	GUIDE	GUIDA CAVO CAMBIO
7A	REC865436A02	865436A02	CABLE CAMBIO R/MR/ALPHA ONE GEN II	R/MR/ALPHA ONE GEN II SHIFT CABLE	CAVO CAMBIO R/MR/ALPHA ONE GEN II
7A	RM19543A10	865436A02	CABLE CAMBIO ORIGINAL R/MR/ALPHA ONE GEN II	R/MR/ALPHA ONE GEN II SHIFT CABLE ORIGINAL	CAVO CAMBIO ORIGINAL R/MR/ALPHA ONE GEN II
7B	REC865437A02	865437A02	CABLE CAMBIO BRAVO	BRAVO SHIFT CABLE	CAVO CAMBIO BRAVO
8	REC8507522	8507522 + 10-31700	KIT ACOPLE CABLE CAMBIO	SHIFT CABLE SLIDE	KIT ACCOPIAMENTO CAVO CAMBIO
9	RM864363A1	864363A1	MICRORRUPTOR	SHIFT PLATE KIT	MICROINTERRUTTORE
10	RM864364A1	864364A1	MICRORRUPTOR	SHIFT PLATE KIT	MICROINTERRUTTORE
11	REC16792A39	16792A39	BOMBA DIRECCIÓN	PUMP ASS. POWER STEERING	POMPA DI STERZO
12	REC12-815472	12-815472	ARANDELA BRAVO	WASHER BRAVO	RONDELLA BRAVO
13	RM11-49910	11-49910	TUERCA BRAVO	NUT BRAVO	DADO BRAVO

**SOPORTE TRANSOM  
GIMBAL HOUSING RING ASSEMBLY  
SUPPORTO TRANSOM  
ALPHA ONE GEN II**

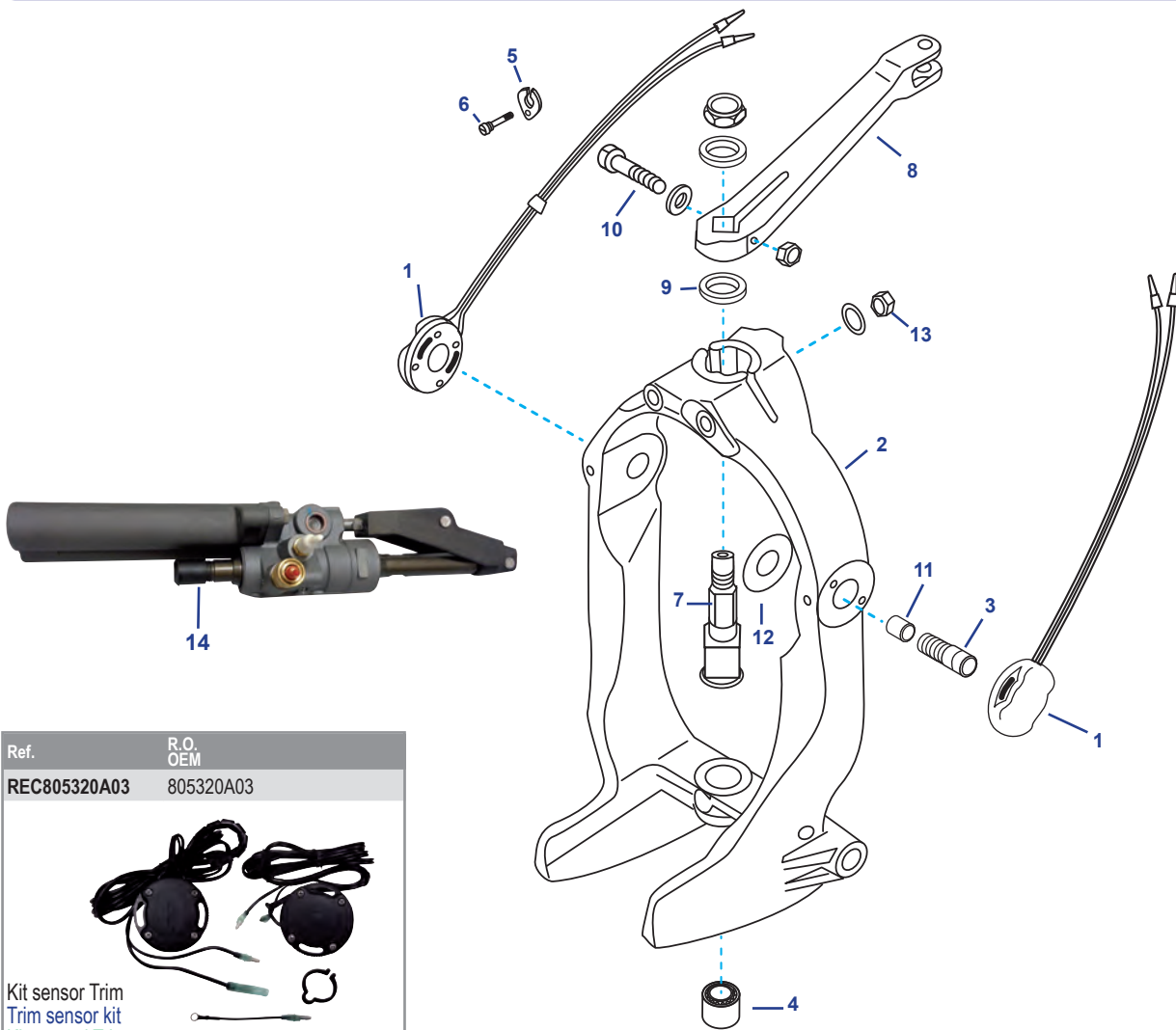

Nº	Ref.	R.O. OEM	Descripción	Description	Descrizione
1	REC805320A03	805320A03	KIT SENSORES TRIM	TRIM SENSOR KIT	KIT SENSORI TRIM
2	RM865328A01	865328A01	SOPORTE TRANSOM Design II (OM815639+)	GIMBAL RING ASSEMBLY Design II (OM815639+)	SUPPORTI TRANSOM Design II (OM815639+)
3	REC77123	77123	TORNILLO ALPHA (-1998) (-OM815638)	ALPHA SCREW (-1998) (-OM815638)	VITE ALPHA (-1998) (-OM815638)
3	REC10-86801	10-86801	TORNILLO ALPHA (1998+) (OM85639+)	ALPHA SCREW (1998+) (OM85639+)	VITE ALPHA (1998+) (OM85639+)
4	RM23-99352	23-99352	COJINETE	BEARING	CUSCINETTO
5	RM54-12078	54-12078	ABRAZADERA	CLAMP	FASCETTA
6	RM10-28635	10-28635	TORNILLO SUJECCIÓN	SCREW	VITE
7	REC98230A1	98230A1	EJE	SHAFT	ASSE
8	RM866322A01	866322A01	BIELA DIRECCIÓN	LEVER ASSY	BIELLA STERZO
9	RM12-98548	12-98548	ARANDELA	WASHER	RONDELLA
10	RM10-807204	10-807204	TORNILLO	SCREW	VITE
11	REC23-847637	23-847637	CASQUILLO	BUSING	BOCCOLA
12	RM12-41721	12-41721	ARANDELA	WASHER	RONDELLA
13	REC11-862903	11-134371	TUERCA	NUT	DADO
14	REC806034A1	866200A01	PISTÓN DIRECCIÓN MODERNA (1991+) PLÁSTICO	NEWER POWER STEERING PISTON (1991+) PLASTIC	PISTONE IDRAULICO MODERNO (1991+) PLASTICA
14	RM806034A2	806034A2	PISTÓN DIRECCIÓN ANTIGUA (-1991) METÁLICA	OLDER POWER STEERING PISTON (-1991) METALIC	PISTONE IDRAULICO VECCHIO (-1991) METALLO

CABEZAL COLA  
BELL HOUSING  
PARTE SUPERIORE TRANSOM  
MC - MR1 - ALPHA ONE - ALPHA ONE GEN II

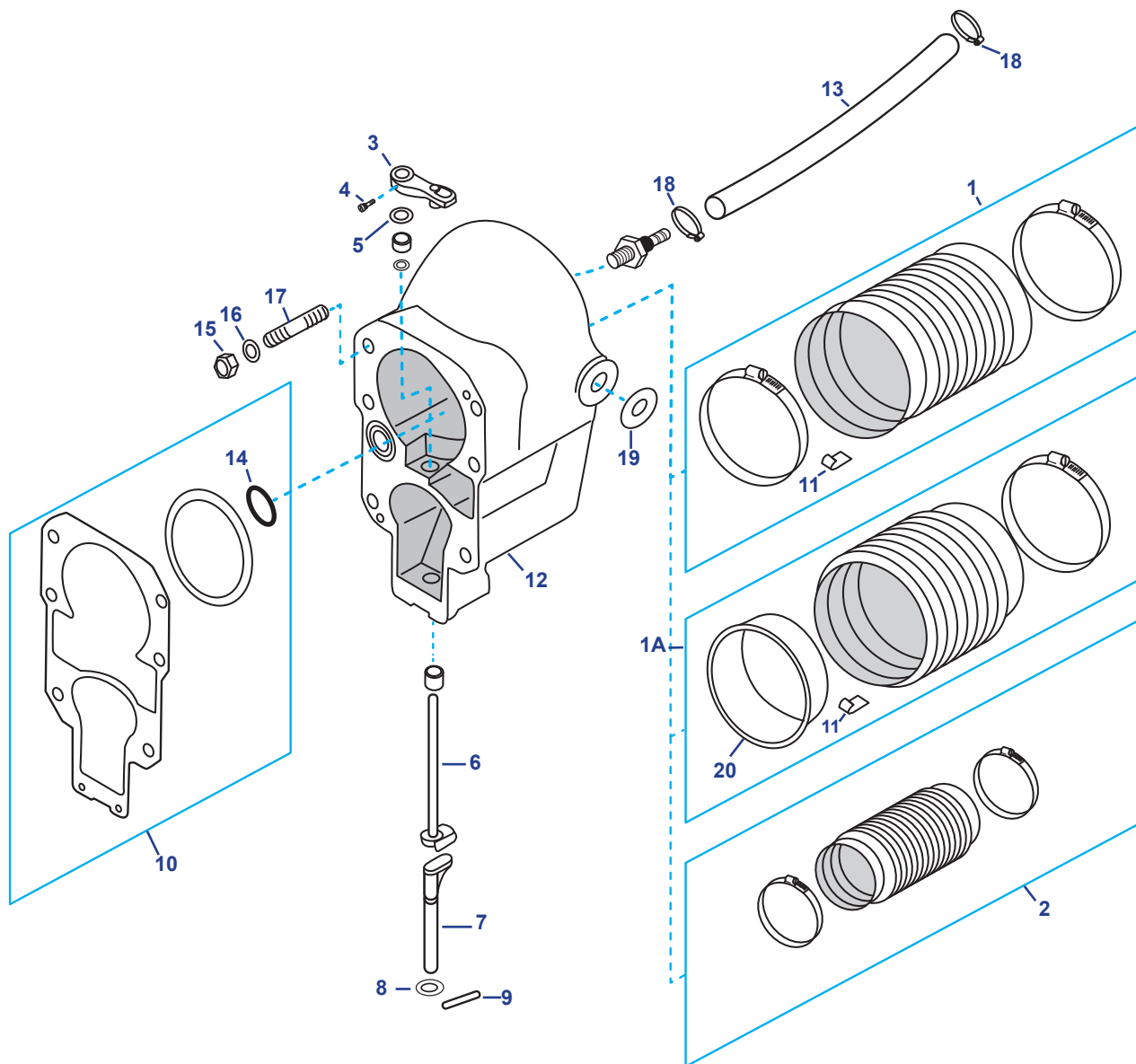

Ref.	R.O. OEM
REC816607	816607



Casquillo fuelle  
Bellow Flange Ring  
Anello

Ref.	R.O. OEM
REC23-806036A1	23-806036A1



Kit retenes  
Shift shaft busing  
Kit tenuta  
Alpha Gen II, (F094775+)

Ref.	R.O. OEM
REC23-805041A2	23-805041A2



Kit retenes  
Shift shaft busing  
Kit tenuta  
R/MR, Alpha Gen II,  
(-F094774)

Ref.	R.O. OEM
REC45518T1	45518T1



Kit cambio  
Shift lever kit  
Kit cambio

Nº	Ref.	R.O. OEM	Descripción	Description	Descrizione
1	REC60932A4	60932A4	KIT FUELLE (3469428+) R/MR/ALPHA ONE	U-JOINT BELLOW (3469428+) KIT R/MR/ALPHA ONE	KIT CUFFIA (3469428+) R/MR/ALPHA ONE
1A	REC816431A1	816431A1	KIT FUELLE ALPHA ONE GEN II	U-JOINT BELLOW KIT ALPHA ONE GEN II	KIT CUFFIA ALPHA ONE GEN II
2	REC18654A1	18654A1	KIT FUELLE ESCAPE	U-JOINT BELLOW KIT	KIT CUFFIA DI SCARICO
3	REC45518A3	45518A3	PASADOR	SHIFT ARM	CHIAVISTELLO
4	REC10-45590	10-45590	TORNILLO CIERRE	SET SCREW	VITE
5	REC12-39116	12-39116	JUNTA	GASKET	GUARNIZIONE
6	REC816685	816685	EJE CABLE CAMBIO ALPHA ONE GEN II	UPPER SHIFT SHAFT ALPHA ONE GEN II	ASSE CAMBIO ALPHA ONE GEN II
6	REC45589A3	45589A3	EJE CABLE CAMBIO ALPHA ONE GEN I	UPPER SHIFT SHAFT ALPHA ONE GEN I	ASSE CAMBIO ALPHA ONE GEN I
7	REC621041	621041	EJE INTERMEDIO	INTERMEDIATE SHIFT SHAFT	ASSE INTERMEDIO
8	REC12-32666	12-32666	ARANDELA	WASHER	RONDELLA
9	REC18-32665	18-32665	PASADOR	COTTER PIN	CHIAVISTELLO
10	REC27-94996Q2	27-94996Q2	KIT JUNTAS TRANSOM ALPHA ONE & GEN II	GASKET KIT ALPHA ONE & GEN II	KIT GUARNIZIONI TRANSOM ALPHA ONE & GEN II
10	REC27-64818Q4	27-64818Q4	KIT JUNTAS TRANSOM MC1	GASKET KIT MC1	KIT GUARNIZIONI TRANSOM MC1
11	REC54-86049	54-86049	CLIP FUELLE	GROUNDING CLIP	CLIP CUFFIA
12	RM42815A6	42815A6	CAMPANA TRANSOM ALPHA ONE (1983-90)	ALPHA ONE BELL HOUSING (1983-90)	CAMPANA TRANSOM ALPHA ONE (1983-90)
12	RM806031A2	806031A2	CAMPANA TRANSOM GEN II (1991+)	GEN II BELL HOUSING (1991+)	CAMPANA TRANSOM GEN II (1991+)
13	REC32-4172533	32-4172533	TUBO AGUA Ø 3/4 13 <sup>7/8</sup> "L	WATER HOSE Ø 3/4 13 <sup>7/8</sup> "L	TUBO ACQUA Ø 3/4" 13 <sup>7/8</sup> "L
13	REC32-32461	32-32461	TUBO AGUA Ø 5/8 13 <sup>7/8</sup> "L	WATER HOSE Ø 5/8 13 <sup>7/8</sup> "L	TUBO ACQUA Ø 5/8" 13 <sup>7/8</sup> "L
14	REC0307239	25-33504	ARO TÓRICO	O-RING	ANELLO
15	REC11-34933	11-134391	TUERCA (.4375-20)	NUT (.4375-20)	DADO (.4375-20)
16	REC12-45176	12-35935	ARANDELA (.435 x .875 x .105)	WASHER (.435 x .875 x .105)	RONDELLA (.435 x .875 x .105)
17	REC16-59579	16-59579	TORNILLO	SCREW	VITE
18	REC54-815504412	54-815504412	ABRAZADERA	CLAMP	FASCETTA
19	REC12-72498	12-72498	ARANDELA	WASHER	RONDELLA
20	REC816607	816607	CASQUILLO FUELLE	BELLOW FLANGE RING	ANELLO

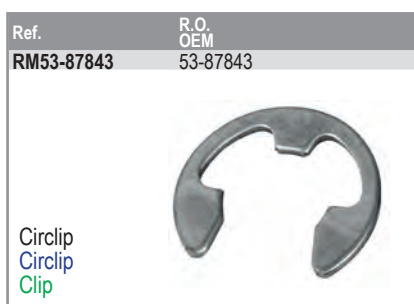

TRANSOM  
GIMBAL HOUSING  
TRANSOM  
BRAVO

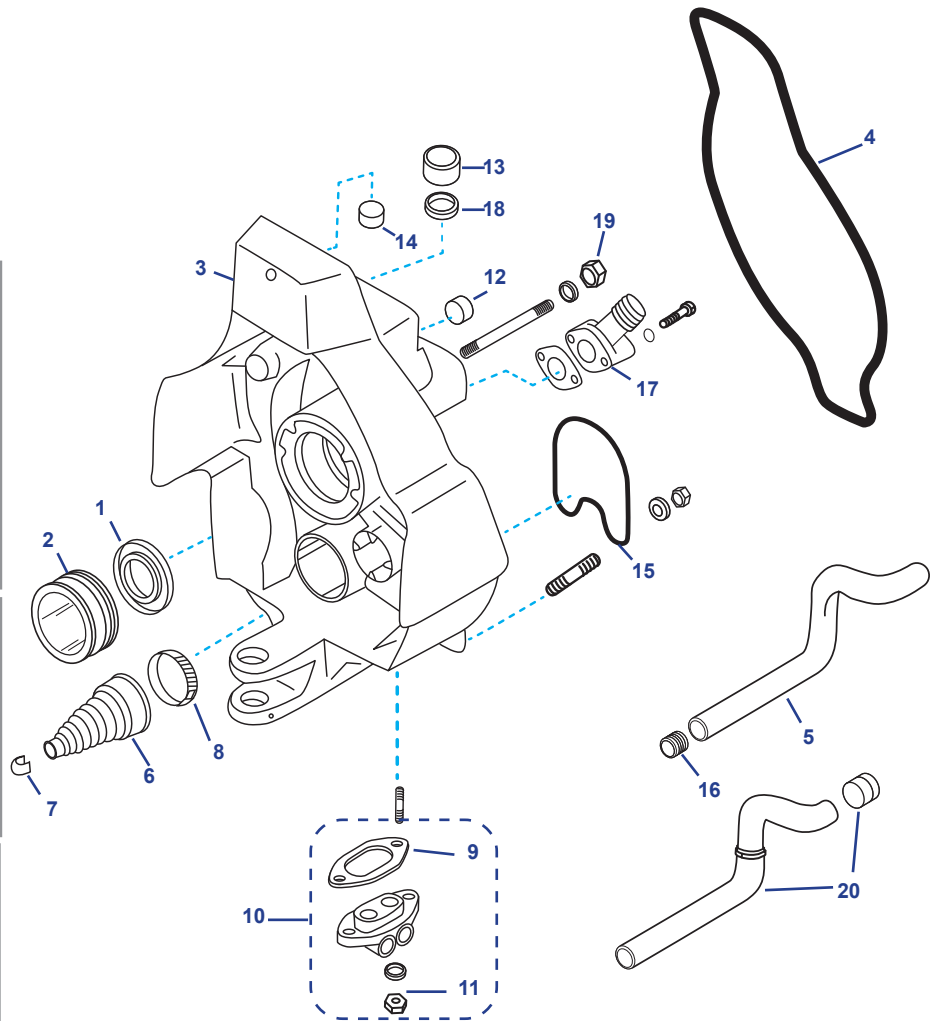
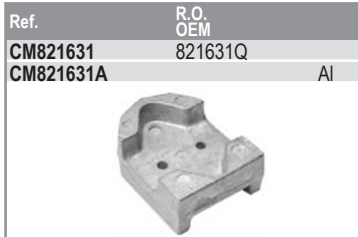

Nº	Ref.	R.O. OEM	Descripción	Description	Descrizione
1	REC26-88416	26-88416	RETÉN ACEITE	OIL SEAL	PARAOLIO
2	REC30-879194A01	879194A01 & A02	COJINETE	GIMBAL BEARING	CUSCINETTO
3	RM43881A17	43881A17	CARCASA	GIMBAL HOUSING ASSY.	CARASSA
4	REC43713	43713	JUNTA TRANSOM	TRANSOM SEAL	GUARNIZIONE TRANSOM
5	REC32-43437	32-43437	TUBO AGUA DESIGN I	WATER HOSE DESIGN I	TUBO ACQUA DESIGN I
6	REC74639Q02	74639Q02	FUELLE CABLE CAMBIO	SHIFT CABLE BELLOW	CUFFIA CAMBIO
7	REC54-38863	54-38863	ABRAZADERA	CLAMP	FASCETTA
8	REC54-815504320	54-815504320	ABRAZADERA	CLAMP	FASCETTA
9	REC27-988231	27-988231	JUNTA	GASKET	GUARNIZIONE
10	REC8M0080805	8M0080805	KIT CONECTOR	CONNECTOR KIT	CONNETTORE
11	REC11-8267089	11-8267089	TUERCA	NUT	DADO
12	REC22-428611	22-428611	TAPÓN	PLUG	TAPPO
13	RM23-983571	23-983571	CASQUILLO INFERIOR	BUSHING - LOWER	BOCCOLA INFERIORE
14	RM23-98356	23-98356	CASQUILLO SUPERIOR	BUSHING - UPPER	BOCCOLA SUPERIORE
15	REC41802	41802	RETÉN	SEAL	TENUTA
16	REC41674T	41674T	CASQUILLO	INSERT	BOCCOLA
17	RM22-43828	22-43828T	CONECTOR (-OW099999)	CONNECTOR (-OW099999)	PIPETTA (-OW099999)
17	RM865470	865470	CONECTOR (OW100000+)	CONNECTOR (OW100000+)	PIPETTA (OW100000+)
18	REC26-8M2005029	26-416071	RETÉN	OIL SEAL	PARAOLIO
19	REC11-34933	11-34933	TUERCA	NUT	DADO
20	REC8M0062102	32-8M0062102	TUBO DE AGUA DESIGN II	WATER HOSE DESIGN II	TUBO ACQUA DESIGN II

# CABEZAL COLA BELL HOUSING PARTE SUPERIORE PIEDE BRAVO

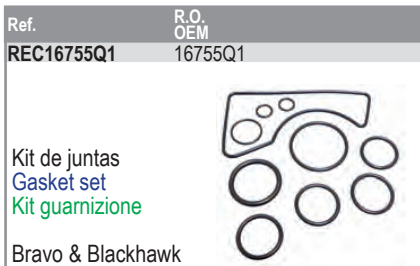
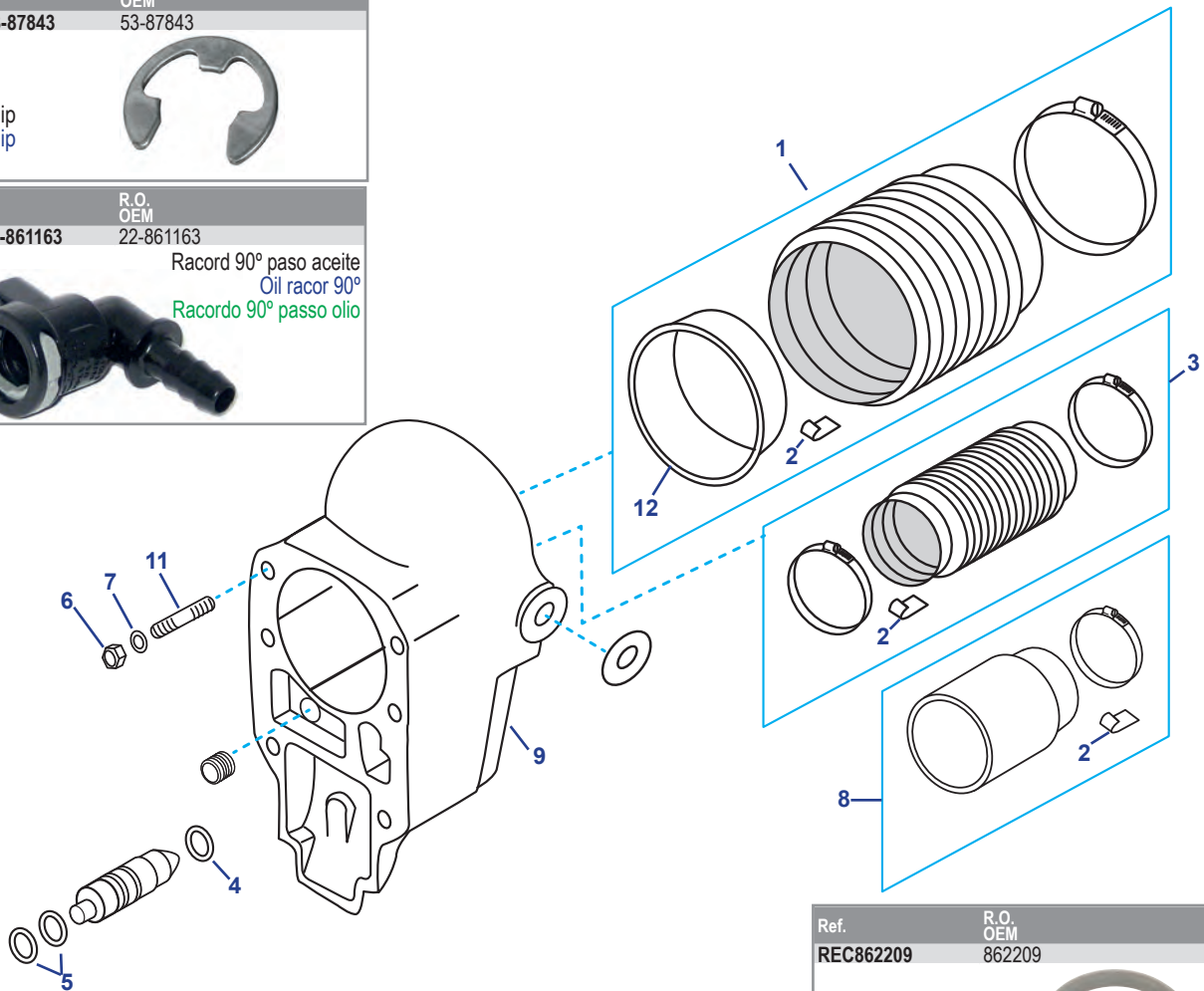
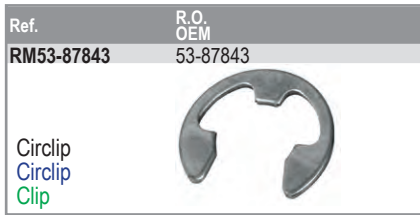

Nº	Ref.	R.O. OEM	Descripción	Description	Descrizione
1	REC86840A05	86840A05	FUELLE TRANSON	U-JOINT BELLOW	CUFFIA TRANSON
2	REC54-86049	54-86049	CLIP	CLIP	CLIP
3	REC18654A1	18654A1	FUELLE ESCAPE	EXHAUST BELLOW	CUFFIA SCARICO
4	REC25-62705	25-62705	ARO	O-RING	ANELLO
5	REC25-48171	25-48171	ARO	O-RING	ANELLO
6	REC11-34933	11-859116	CIERRE	LOCKNUT	CHIUSURA
7	REC12-45176	12-35935	ARANDELA	WASHER	RONDELLA
8	REC78458A1	78458A1	TUBO ESCAPE	EXHAUST TUBE	TUBO DI SCARICO
9	RM41646A9	41646A9	CAMPANA BRAVO I, II, III	BRAVO I, II, III BELL HOUSING	CAMPANA BRAVO I, II, III
11	REC16-59579	16-59579	TORNILLO	SCREW	VITE
12	REC862209	862209	CASQUILLO FUELLE	BELLOW FLANGE RING	ANELLO



**SOPORTE TRANSOM  
GIMBAL HOUSING RING ASSEMBLY  
SUPPORTO TRANSOM  
BRAVO ONE (I, II, III)**

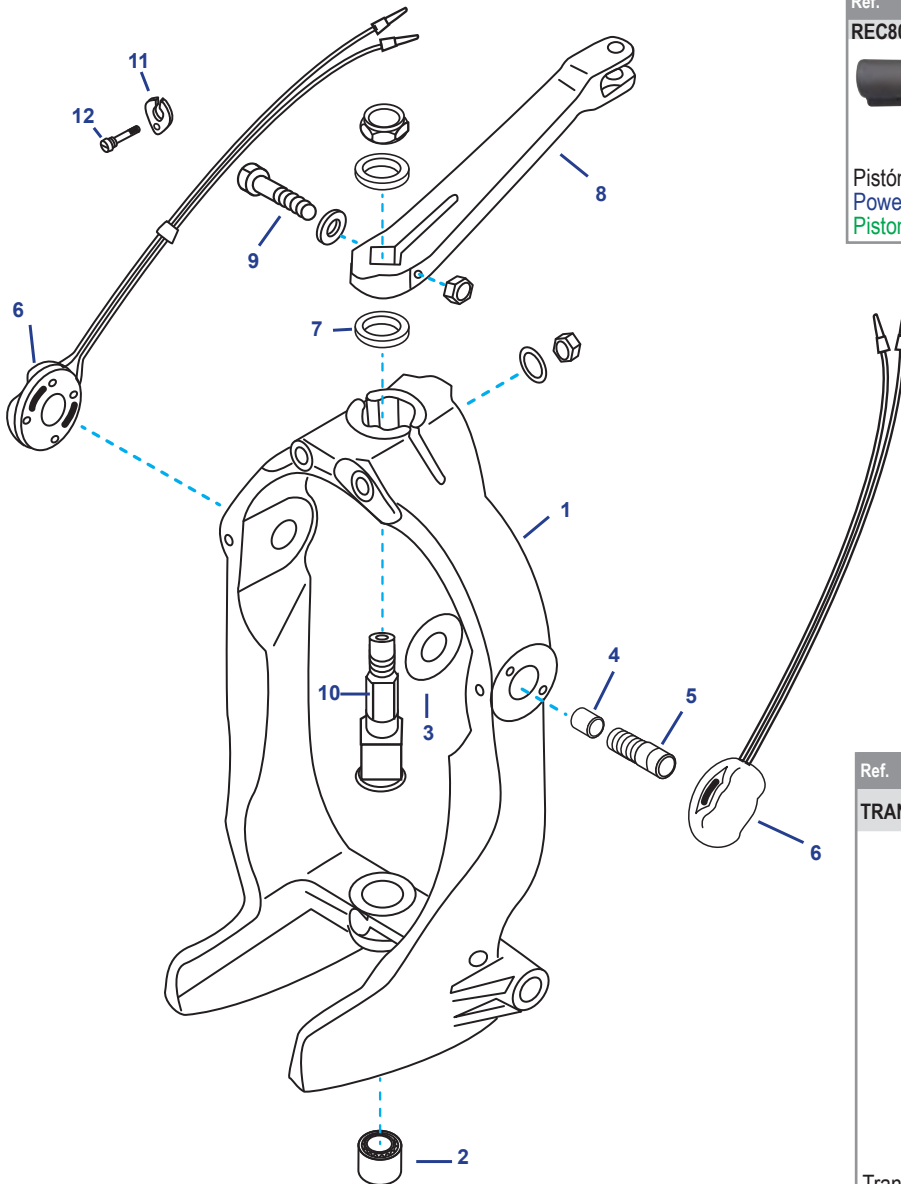

Ref.	R.O. OEM
REC806034A1	866200A01

Pistón dirección moderna (1991+)  
Power steering piston (1991+)  
Pistone sterzo moderno (1991+)

Ref.	R.O. OEM
TRANSONBRAVO	6-6211002NZ 6-6311002NZ

Transom Completo  
Transom Assembly  
Transom Completo

Nº	Ref.	R.O. OEM	Descripción	Description	Descrizione
1	RM8M0062440	8M0062440	SOPORTE TRANSOM	GIMBAL RING ASSEMBLY	SUPPORTO TRANSOM
2	RM23-847638	23-847638	COJINETE MAGNUM	BEARING MAGNUM	CUSCINETTO MAGNUM
2	RM23-99352	23-99352	COJINETE ESTÁNDAR	BEARING STANDARD	CUSCINETTO STANDARD
3	RM12-41721	12-41721	ARANDELA	WASHER	RONDELLA
4	REC23-847637	23-847637	CASQUILLO	BUSHING	BOCCOLA
5	REC10-86801	10-86801	TORNILLO (1998+)	SCREW (1998+)	VITE (1998+)
6	REC805320A03	805320A03	KIT SENSORES TRIM	TRIM SENSOR KIT	KIT SENSORI TRIM
7	RM12-98548	98548	ARANDELA	WASHER	RONDELLA
8	RM866322A01	866322A01	BIELA DIRECCIÓN	LEVER ASSY	BIELLA STERZO
9	RM10-807204	10-807204	TORNILLO	SCREW	VITE
10	REC98230A1	98230A1	EJE	SHAFT	ASSE
11	RM54-12078	54-12078	ABRAZADERA	CLAMP	FASCETTA
12	RM10-28635	10-28635	TORNILLO	SCREW	VITE

## KITS DE JUNTAS GASKETS SETS KIT GUARNIZIONI

Ref.	R.O. OEM
REC27-54014Q1	27-54014Q1

MOTORES / ENGINES / MOTORI  
TR/TRS

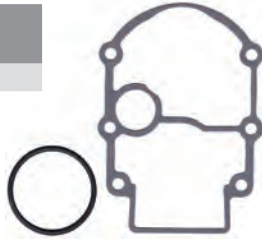

Ref.	R.O. OEM
REC87580	

MOTORES / ENGINES / MOTORI  
TR/TRS

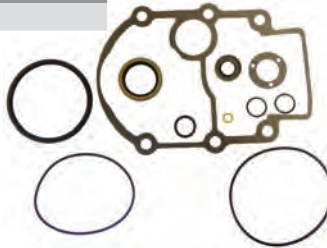

Ref.	R.O. OEM
REC16755Q1	16755Q1

MOTORES / ENGINES / MOTORI  
Bravo



Ref.	R.O. OEM
REC27-64818Q4	27-64818Q4

MOTORES / ENGINES / MOTORI  
MC1/120 - 260

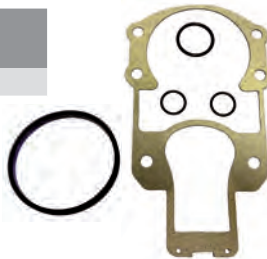

Ref.	R.O. OEM
REC27-94996Q2	27-94996Q2

MOTORES / ENGINES / MOTORI  
MC1/R/MR/Alpha One/Gen II

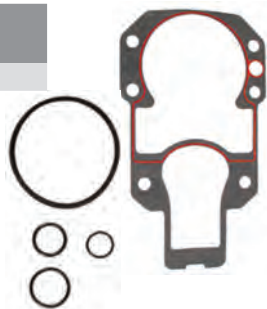

## CABLE CAMBIO SHIFT CABLE ASSY CAVO CAMBIO

Ref.	R.O. OEM
REC21470	

MOTORES / ENGINES / MOTORI  
MCM  
Modelos modernos  
Newer models  
Modello moderno



Ref.	R.O. OEM
REC865436A02	865436A02
RM19543A10	ORIGINAL

MOTORES / ENGINES / MOTORI  
MCM  
Modelos modernos  
Newer models  
Modello moderno

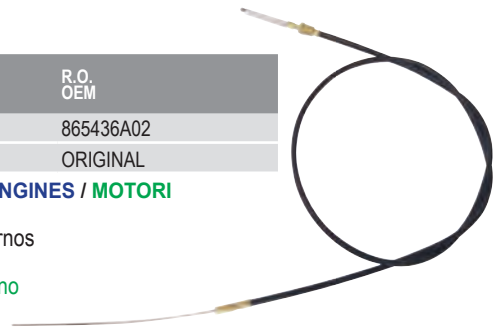

Ref.	R.O. OEM
REC865437A02	865437A02

MOTORES / ENGINES / MOTORI  
Bravo I, II, III



## KIT CABLE CAMBIO SHIFT CABLE ASSY KIT KIT CAVO CAMBIO

Ref.	R.O. OEM
REC865436A03	

MOTORES / ENGINES / MOTORI  
MC1/R/MR/Alpha One/Gen II



Ref.	R.O. OEM
REC815471T1	815471T1

MOTORES / ENGINES / MOTORI  
Bravo I, II, III



## SOPORTE MOTOR ENGINE MOUNT SCREW SUPPORTI MOTORE

Ref.	R.O. OEM	TORNILLO SCREW VITE
GS38105	814263A1	19 mm = 3/4"
GS38122	35852	16 mm = 5/8"



**ACOPLAMIENTOS MOTOR  
ENGINE COUPLER ASSEMBLIES  
ACCOPIAMENTO MOTORE**

Ref.	R.O. OEM
REC76850A2	76850A2

Se usa en todos los Chevys antiguos en los que el retén trasero del cigüeñal es de dos piezas.  
Used on all older Chevy engines with 2 piece rear main seals.

Si usa in tutti i Chevy con paraolio posteriore in Si usa in tutti i Chevy vecchio con paraolio posteriore in 2 pz. 4 cil V6 e V8.



GM MR / ALPHA / BRAVO

Ref.	R.O. OEM
REC69354A2	69354A2

**MOTORES / ENGINES / MOTORI**

470, 485  
Serie 42208730-6218036 (1976-82)



Ref.	R.O. OEM
REC97432A2	97432A2

**MOTORES / ENGINES / MOTORI**

165, 170, 470, 180, 190, 488, 3.7LX, 3.7L  
Serie 6170297+  
(1983-89)



Ref.	R.O. OEM
REC18643A7	18643A7

**MOTORES / ENGINES / MOTORI**

V6 & V8  
Con volante grande 14"  
For engines with 14" flywheel  
Con volano grande 14"



Ref.	R.O. OEM
REC12632A7	12632A7

**MOTORES / ENGINES / MOTORI**

4L  
Con volante pequeño 12 3/4"  
For engines with 12 3/4" flywheel  
Con volano piccolo 12 3/4"



Ref.	R.O. OEM
REC861523A9	861523A9

**MOTORES / ENGINES / MOTORI**

5.7, 7.4, 454 Magnum & 502  
Con colas Bravo  
Engines with Bravo drives  
Piedi Bravo



Ref.	R.O. OEM
REC59826A3	59826A3

**MOTORES / ENGINES / MOTORI**

Ford



Ref.	R.O. OEM
REC14505A2	14505A2

**MOTORES / ENGINES / MOTORI**

Utilizado al reemplazar V6 o V8, 2 piezas de retén trasero con perno de cigüeñal de 3 1/2", retén trasero de 1 pieza con perno de 3".

Used when replacing V6 or V8, 2 pieces rear main seal with 3 1/2" crankshaft bolt pattern to a newer 1 piece rear main seal engine with 3" bolt pattern.

Utilizzato per sostituire V6 o V8, paraolio posteriore in 2 pezzi con perno dell'albero motore con 3 1/2", perno posteriore de 1 pezzo da 3".



**KITS MONTAJE  
ENGINE MOUNT KIT  
KIT RIPARAZIONE ACCOPIAMENTO**

Ref.	R.O. OEM
REC10-97934A1	10-97934A1



Ref.	R.O. OEM
REC21811	



**KITS SILEMBLOCKS**

Ref.	R.O. OEM
REC865329A02	865329A02



**COMPONENTES SILEMBLOCK  
SILEMBLOCK COMPONENTS  
COMPONENTI SILEMBLOCK**

Ref.	R.O. OEM			
REC23-99322	23-99322	ESPACIADOR	SPACER	DISTANZIALE
REC23-99299	23-99299	ESPACIADOR	SPACER	DISTANZIALE
REC12-32834	12-32834	ARANDELA FIBRA	FIBRE WASHER	RONDELLA FIBRA
REC12-35777	12-35777	ARANDELA	WASHER	RONDELLA
REC10-97934	10-97934	TORNILLO	SCREW	VITE
REC11-863332	11-863332	CIERRE	LOCK	CHIUSURA
REC13-33734	13-33734	MUELLE	SPRING	MOLLA



**KIT FUELLE TRANSOM**  
**TRANSOM U-JOINT BELLOWS KIT**  
**KIT CUFFIE TRANSOM**

Ref.	R.O. OEM
REC60932A4	60932A4
CEF500516K	60932A1

**MOTORES / ENGINES / MOTORI**  
1/R/Alpha One (3469428+)



Ref.	R.O. OEM
REC36223A2	36223A2
CEF500522K	36223
	36223A1

**MOTORES / ENGINES / MOTORI**  
Colas antiguas  
Old styles drives  
Piedi vecchio  
(-3443920)



Ref.	R.O. OEM
REC86840A05	8M0062406
	86840A3
CEF500509K	86840A05

**MOTORES / ENGINES / MOTORI**  
Bravo & Blackhawk



Ref.	R.O. OEM
REC816431A1	816431A1
CEF500515K	

**MOTORES / ENGINES / MOTORI**  
Alpha One Gen II



**KIT FUELLE CABLE CAMBIO**  
**SHIFT CABLE BELLOW SET**  
**KIT CUFFIA CAMBIO**

Ref.	R.O. OEM
REC74639Q02	74639Q02
CEF500513K	

**MOTORES / ENGINES / MOTORI**  
Alpha & Bravo



**CLIP FUELLE**  
**BELLOW CLIP**  
**CLIP CUFFIE**

Ref.	R.O. OEM
REC54-86049	54-86049



**ABRAZADERA FUELLE CAMBIO**  
**SHIFT CABLE BELLOW CLAMP**  
**FASCETTA CUFFIE CAMBIO**

Ref.	R.O. OEM	FUELLE BELLOW CUFFIA
REC54-38863	54-38863	REC74639Q02



Ref.	R.O. OEM	FUELLE BELLOW CUFFIA
REC54-815504320	54-815504320	REC74639Q02



**MANGUITO DE ESCAPE**  
**EXHAUST TUBE**  
**TUBO DI SCARICO**

Ref.	R.O. OEM
REC78458A1	78458A1
CEF500520K	78458

**MOTORES / ENGINES / MOTORI**  
Bravo I, II & III



Ref.	R.O. OEM
REC18654A1	18654A1
	32734
CEF500512K	32734A3

**MOTORES / ENGINES / MOTORI**  
Alpha & Bravo



**PROTECTORES SALIDA ESCAPE**  
**EXHAUST PROTECTOR VALVES**  
**PROTEZIONE SCARICO**

Ref.	R.O. OEM	Ø
REC34765A2	34765A2	76 mm = 3"
REC12644A1	12644A1	101 mm = 4"
		127 mm = 5"
REC89260		152 mm = 6"



# COMPONENTES CAMBIO SHIFT COMPONENTS COMPONENTI CAMBIO

**EJE CABLE CAMBIO SUPERIOR  
UPPER SHIFT SHAFT  
ALBERINO SUPERIORE CAMBIO**

Ref.	R.O. OEM
REC45589A3	45589A3

**MOTORES / ENGINES / MOTORI  
MC-1/R/MR/Alpha One**



Ref.	R.O. OEM
REC816685	816685

**MOTORES / ENGINES / MOTORI  
Alpha One Gen II**



**EJE CABLE CAMBIO INTERMEDIO  
INTERMEDIATE SHIFT SHAFT  
ASSE INTERMEDIO CAMBIO**

Ref.	R.O. OEM
REC621041	621041

**MOTORES / ENGINES / MOTORI  
MC-1/R/MR/Alpha One**



**EJE YOKE  
YOKE SHAFT  
ASSE YOKE**

Ref.	R.O. OEM
REC12711	12711

**MOTORES / ENGINES / MOTORI  
Bravo I, II & III**



**TORNILLO  
SCREW  
VITE**

Ref.	R.O. OEM
REC10-45590	10-45590
REC10-31700	10-31700

**MOTORES / ENGINES / MOTORI  
MC-1 / R / MR / Alpha One / Alpha One Gen II**



**PASADOR  
PIN  
SPINOTTO**

Ref.	R.O. OEM
REC45518A3	45518A3

**MOTORES / ENGINES / MOTORI  
MC-1 / R / MR / Alpha One / Alpha One Gen II**



**KIT CAMBIO  
SHIFT LEVER KIT  
KIT CAMBIO**

Ref.	R.O. OEM
REC45518T1	45518T1

**MOTORES / ENGINES / MOTORI  
MC-1/R/MR/Alpha One / Alpha One  
Gen II**



**KIT RETÉN  
SEAL KIT  
KIT TENUTE**

Ref.	R.O. OEM
REC23-806036A1	23-806036A1

**MOTORES / ENGINES / MOTORI  
Alpha One Gen II (F094775+)**



Ref.	R.O. OEM
REC23-805041A2	23-805041A2

**MOTORES / ENGINES / MOTORI  
MC-1 / R / MR / Alpha One / Alpha One Gen II**



Ref.	R.O. OEM
REC23-861209A1	23-861209A1

**MOTORES / ENGINES / MOTORI  
Bravo I, II & III**



**ACOPLE CABLE  
CABLE SLIDE  
ACCOPIAMENTO CAVO**

Ref.	R.O. OEM
REC8507522	8507522

**MOTORES / ENGINES / MOTORI  
MC-1 / R / MR / Alpha One / Alpha One Gen II**



**GUÍA CABLE  
CABLE GUIDE  
GUIDA CAVO**

Ref.	R.O. OEM
REC02644	



**ANCLAJE CABLE  
CABLE ANCHOR  
FERMA CAVO**

Ref.	R.O. OEM
REC43436	43436

Se instala en guía de cable REC02644  
Installed in cable guide REC02644  
Viene installato nei passacavi REC02644



**TORNILLO PARA ANCLAJE REC43436  
SCREW FOR REC43436  
VITE PER REC43436**

Ref.	R.O. OEM
REC10-20518	10-20518



# BRAZOS POWER TRIM Y MANGUERAS HIDRÁULICAS MODELS POWER TRIM ARMS & POWER STEERING HOSES PISTONI POWER TRIM E TUBI IDRAULICI

120-140-165-228-250-260-470-485-888-898

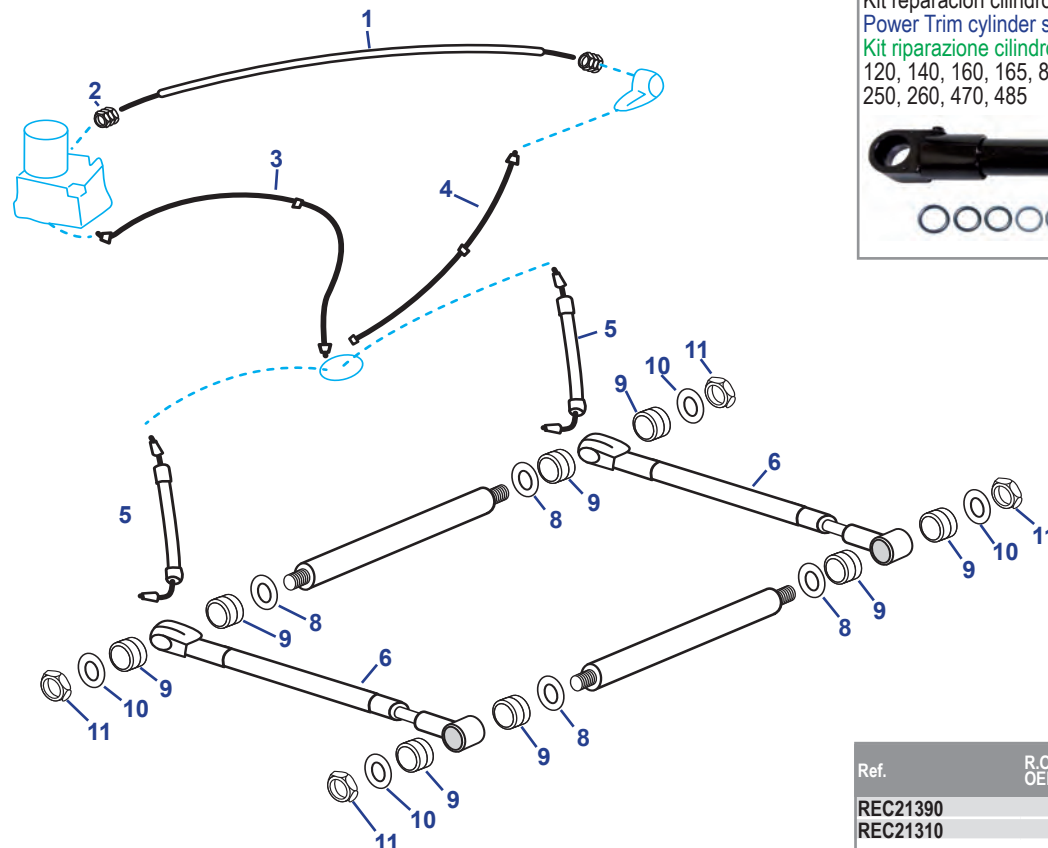

Ref.	R.O. OEM
<b>REC21990</b>	
Kit reparación cilindro power Trim Power Trim cylinder service kit Kit riparazione cilindro Power Trim	
120, 140, 160, 165, 888, 898, 228, 225-S, 233, 250, 260, 470, 485	

Ref.	R.O. OEM
<b>REC77442A1</b>	77442A1
Cuerpo cilindro power trim Power trim cylinder housing kit Corpo cilindro Power Trim	
MC1 (1970-80)	

Ref.	R.O. OEM
<b>REC25-60342A2</b>	25-60342A2
Kit de aros y tubo O-ring kit & tube Kit anelli e tubi	

Ref.	R.O. OEM	EJE RAM ASSE
<b>REC21390</b>		19 cm
<b>REC21310</b>		26 cm
Kit eje sujeción power trim Para colas antiguas con gruesos pequeños en el eje de sujeción delantero. Power trim ram bushing kit for front anchor pin on early Mercruisers with small rubber bushings. Kit Power trim. Per vecchie piedi con piccoli spessori sull'asse di fissaggio anteriore		
MC1 120-260		

Nº	Ref.	R.O. OEM	Descripción	Description	Descrizione
1	REC32-58432A2	32-58432A2	LATIGUILLO TRIM (V8)	TRIM HOSE ASSEMBLY (V8)	TUBO TRIM (V8)
2	RM22-49718	22-49718	TUERCA TUBO	NUT HOSE	DADO TUBO
3	REC32-55816	33-55816	LATIGUILLO TRIM (INLINE)	TRIM HOSE (INLINE)	TUBO TRIM (INLINE)
3	REC32-59841	32-59841	LATIGUILLO TRIM (Conector a bomba) V-8	TRIM HOSE (Connector to pump) V-8	TUBO TRIM (Connettore a pompa) V8
4	REC32-59842	32-59842	LATIGUILLO TRIM	TRIM HOSE	TUBO TRIM
5	REC32-86036	32-86036	LATIGUILLO TRIM	TRIM HOSE	TUBO TRIM
6	REC45706A14	45706A14	BRAZO TRIM	TRIM CYLINDER	BRACCIO TRIM
8		12-45737	ARANDELA	WASHER	RONDELLA
9	REC23-89574	23-89574	ADAPTADOR GOMA	POWER TRIM RAM BUSHING	ADATTATORE IN GOMMA
10	REC12-46765	12-46765	ARANDELA	WASHER	RONDELLA
11	REC11-862903	82671013	TUERCA ACERO INOX	LOCK NUT	DADO ACCIAIO INOX

**R/MR/ALPHA ONE (1983-90)**

Ref. R.O. OEM  
**REC8M0080805** 8M0080805

**NEW**



Kit conector Trim  
 Trim connector kit  
 Kit connettore Trim

Ref. R.O. OEM  
**REC87399A2** 87399A2



Kit reparación Trim  
 Power trim cylinder overhaul kit  
 Kit riparazione cilindro  
 ALPHA ONE Gen I

Ref. R.O. OEM  
**REC88035** 88035



Tapón cilindro Power Trim  
 Power trim ram end cap  
 Tappo cilindro Power Trim  
 Ø 52,8 mm (ext)

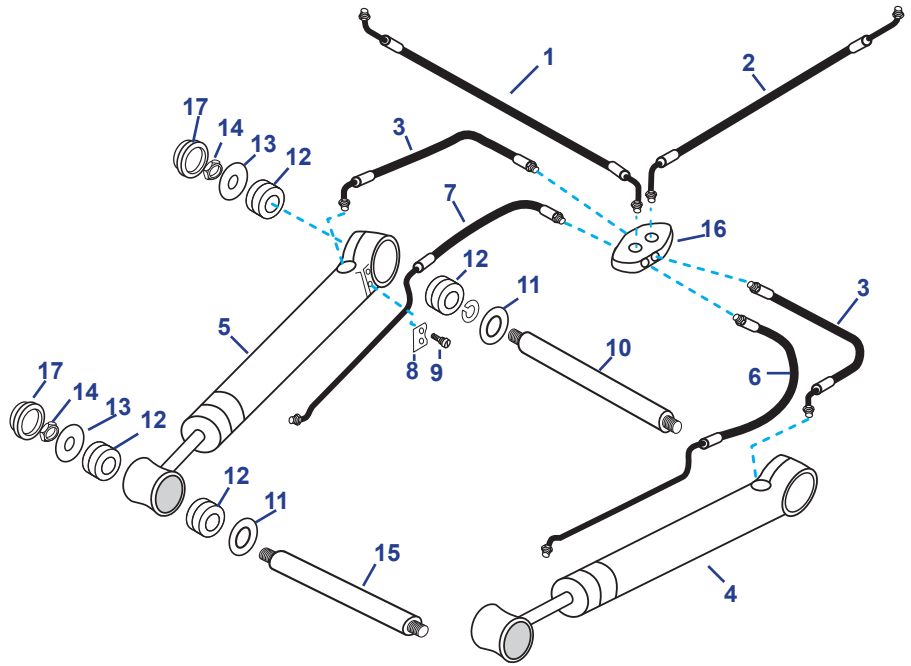

Ref.	R.O. OEM	EJE RAM ASSE
<b>REC21380</b>	17-14872A1	23 cm
<b>REC21370</b>	17-14873A1	30 cm

KIT EJE SUJECCIÓN POWER TRIM  
 Para colas con gruesos grandes en los ejes de sujeción  
**POWER TRIM RAM BUSHING KIT**  
 For rear anchor pin on late Mercruisers with large rubber bushings  
**KIT ASSE POWER TRIM**  
 Per code con grandi spessori sugli alberi



Nº	Ref.	R.O. OEM	Descripción	Description	Descrizione
1	REC32-861127	32-861127	LATIGUILLO TRIM (-OW099999)	TRIM HOSE (-OW099999)	TUBO TRIM (-OW099999)
2	REC32-861128	32-861128	LATIGUILLO TRIM (-OW099999)	TRIM HOSE (-OW099999)	TUBO TRIM (-OW099999)
3	REC32-99904	32-99904Q	LATIGUILLO TRIM	TRIM HOSE	TUBO TRIM
4	REC98704A3	98704A3	BRAZO TRIM ESTRIBOR (395 mm)	TRIM CYLINDER STBD (395 mm)	PISTONE TRIM TRIBORDO (395 mm)
4	REC14034A3	14034A3	BRAZO TRIM ESTRIBOR (411 mm) Negro	TRIM CYLINDER STBD (411 mm) Black	PISTONE TRIM TRIBORDO (411 mm) Nero
5	REC98703A3	98703A3	BRAZO TRIM BABOR (395 mm)	TRIM CYLINDER PORT (395 mm)	PISTONE TRIM BABORDO (395 mm)
5	REC14035A3	14035A3	BRAZO TRIM BABOR (411 mm) Negro	TRIM CYLINDER PORT (411 mm) Black	PISTONE TRIM BABORDO (411 mm) Nero
6	REC32-864589	32-864589	LATIGUILLO TRIM PARA REC98704A3	TRIM HOSE FOR REC98704A3	TUBO TRIM PER REC98704A3
6	REC32-864960	32-864960	LATIGUILLO TRIM PARA REC14034A3	TRIM HOSE FOR REC14034A3	TUBO TRIM PER REC14034A3
7	REC32-864588	32-864588	LATIGUILLO TRIM PARA REC98703A3	TRIM HOSE FOR REC98703A3	TUBO TRIM PER REC98703A3
7	REC32-864959	32-864959	LATIGUILLO TRIM PARA REC14035A3	TRIM HOSE FOR REC14035A3	TUBO TRIM PER REC14035A3
8	REC85060	85060	SUJECCIÓN TUBO	PLATE	SUPPORTO TUBO
9	REC10-85486	10-85486	TORNILLO	SCREW	VITE
10	REC17-14873A1	17-14873A1	EJE SUJECCIÓN (30 cm)	ANCHOR PIN	ASSE DA 30 cm
11	REC12-85058	12-85058	ARANDELA	WASHER	RONDELLA
12	REC23-99291	23-99291T	ADAPTADOR GOMA POWER	BALL GEAR NUT	ADATTATORE IN GOMMA POWER
13	REC12-44163	12-44163	ARANDELA	WASHER	RONDELLA
14	REC11-34933	11-859116	TUERCAACERO INOX	LOCK NUT	DADO ACCIAIO INOX
15	REC17-14872A1	17-14872A1	EJE SUJECCIÓN (23 cm)	ANCHOR PIN	ASSE SUPPORTO (23 cm)
16	REC8M0080805	8M0080805	KIT CONECTOR	TRIM CONNECTOR KIT	CONNETTORE
17	REC19-14842	19-14842	TAPA PLÁSTICO	CAP	COPERCHIO IN PLASTICA

Para saber la referencia del pistón debemos revisar el nº grabado en el brazo  
 Number on cylinder must be checked in order to know piston reference  
 Per sapere il codice del pistone bisogna verificare il nº stampigliato.

ALPHA ONE GEN II (1991+)

Ref. R.O. OEM  
REC8M0080805 8M0080805

**NEW**

Kit conector Trim  
Trim connector kit  
Kit connettore Trim

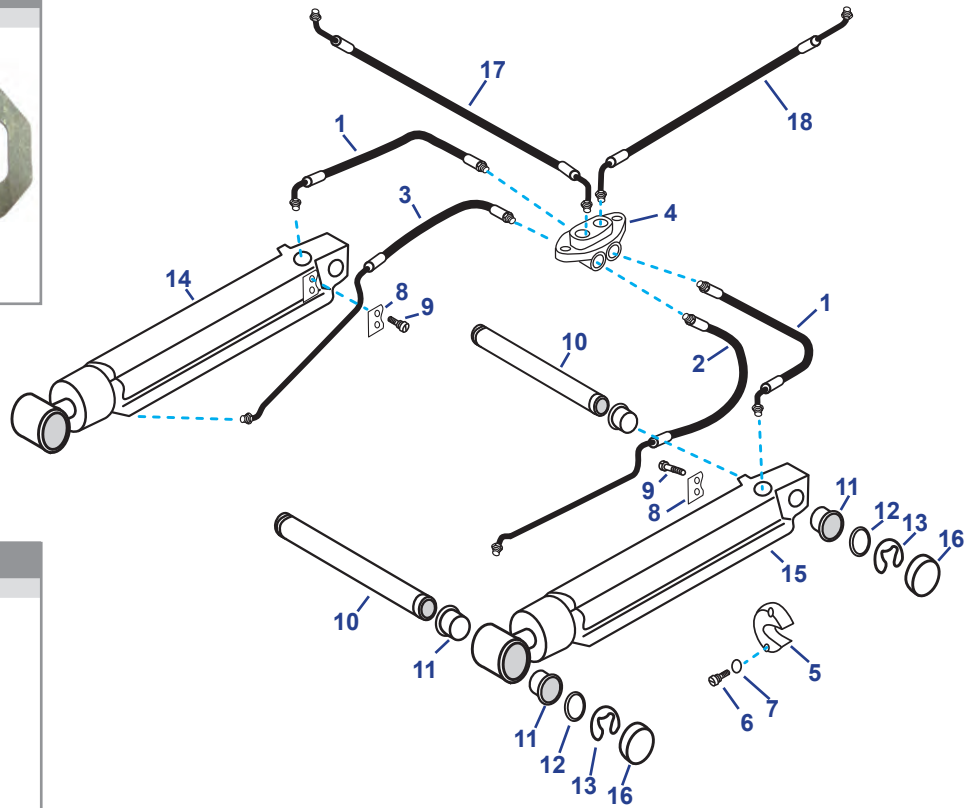

Ref. R.O. OEM  
REC806191T 806191T

Tapón cilindro Power Trim  
Power trim ram end cap  
Tappo cilindro Power Trim  
Ø 48 mm (ext)

Ref. R.O. OEM  
REC87399A3 87399A3

Kit reparación trim  
Power trim cylinder overhaul kit  
Kit riparazione Trim

Ref. R.O. OEM  
REC25-87400A2 25-87400A2

Kit retenes  
Power trim seal kit  
Kit tenute

Ref. R.O. OEM  
REC17-8M0065070

Kit eje sujeción  
Power trim ram bushing kit  
Kit supporto

Nº	Ref.	R.O. OEM	Descripción	Description	Descrizione
1	REC32-99904	32-99904Q	LATIGUILLO TRIM	TRIM HOSE	TUBO TRIM
2	REC32-864960	32-864960	LATIGUILLO TRIM	TRIM HOSE	TUBO TRIM
3	REC32-864959	32-864959	LATIGUILLO TRIM	TRIM HOSE	TUBO TRIM
4	REC8M0080805	8M0080805	KIT CONECTOR	TRIM CONNECTOR KIT	KIT CONNETTORE TRIM
5	CM806189	806189Q1	ÁNODO ZINC	ZINC ANODE	ANODO ZINCO
5	CM806189A	806189Q1	ÁNODO ALUMINIO	ALUMINUM ANODE	ANODO ALLUMINIO
6	REC10-806290	10-806290	TORNILLO	SCREW	VITE
7	REC304454	13-69432	ARANDELA	WASHER	RONDELLA
8	REC85060	85060	SUJECCIÓN TUBO	PLATE	SUPPORTO TUBO
9	REC10-85486	10-85486	TORNILLO (.250 -20x.380)	SCREW (.250 -20x.380)	VITE (.250 -20x.380)
10	REC17-815953A01	17-815953A01	EJE	UPPER SHIFT SHAFT	ASSE
11	REC23-8159501	23-8159501	CASQUILLO	POWER TRIM RAM BUSHING	BOCCOLA
12	REC12-815952	12-815952	ARANDELA	WASHER	RONDELLA
13	REC53-815949	53-815949	CIERRE METÁLICO	E-RING	CHIUSURA METALLICA
14	REC815935A7	815935A7	CILINDRO TRIM BABOR	TRIM CYLINDER PORT	CILINDRO TRIM SINISTRO
15	REC815954A7	815954A7	CILINDRO TRIM ESTRIBOR	TRIM CYLINDER STBD	CILINDRO TRIM DESTRO
16	REC19-815951	19-815951	TAPA PLÁSTICO	PLASTIC CAP	COPERCHIO IN PLASTICA
17	REC32-861127	32-861127	LATIGUILLO TRIM (-OW099999) Negro	TRIM HOSE (-OW099999) Black	TUBO TRIM (-OW099999) Nero
18	REC32-861128	32-861128	LATIGUILLO TRIM (-OW099999) gris	TRIM HOSE (-OW099999) Grey	TUBO TRIM (-OW099999) Grigio



**BRAVO**

Ref. R.O. OEM  
**REC8M0080805** 8M0080805

**NEW**

Kit conector Trim  
 Trim connector kit  
 Kit connettore Trim

Ref. R.O. OEM  
**REC806191T** 806191T

Tapón cilindro Power Trim  
 Power trim ram end cap  
 Tappo cilindro Power Trim  
 Ø 48 mm (ext)

Ref. R.O. OEM  
**REC87399A2** 87399A2

Kit reparación trim  
 Power trim cylinder overhaul kit  
 Kit riparazione Trim

Ref. R.O. OEM  
**REC25-87400A2** 25-87400A2

Kit retenes  
 Power trim seal kit  
 Kit tenute

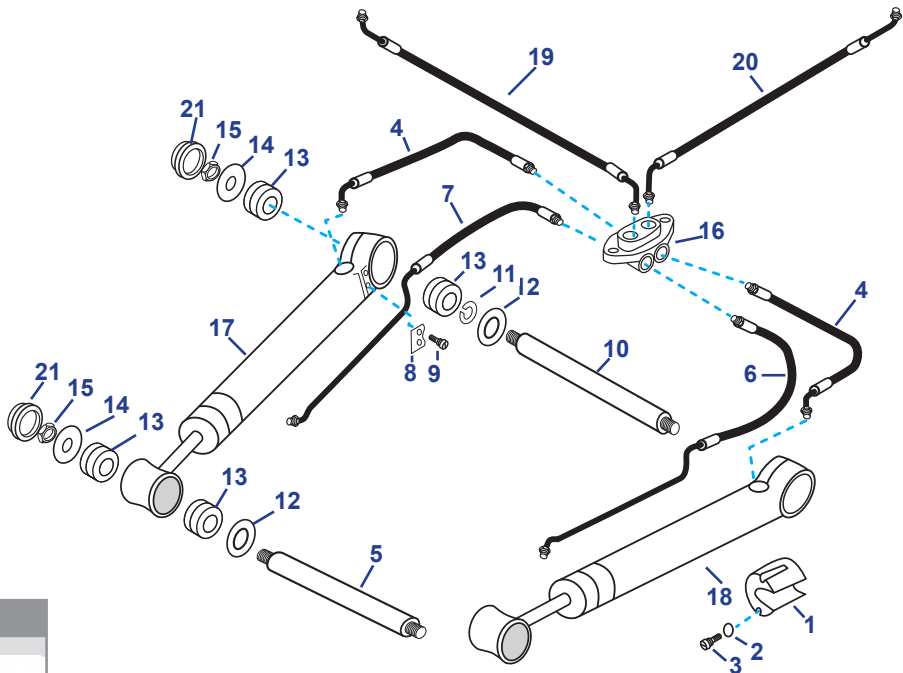

Ref. R.O. OEM  
**REC14-44166T1** 17-44166T1

KIT eje sujeción trasero  
 Power trim ram bushing kit (rear)  
 Kit asse posteriore

Ref. R.O. OEM  
**REC21920**

KIT eje sujeción delantero  
 Power trim ram bushing kit (front)  
 Kit asse anteriore

Nº	Ref.	R.O. OEM	Descripción	Description	Descrizione
1	CM806190	806190A1	ÁNODO ZINC	ZINC ANODE	ANODO ZINCO
1	CM806190A	806190A1	ÁNODO ALUMINIO	ALUMINUM ANODE	ANODO ALLUMINIO
2	REC304454	13-69432	ARANDELA	WASHER	ANODO ALLUMINIO
3	REC10-806290	10-806290	TORNILLO	SCREW	VITE
4	REC32-99904	32-99904Q	LATIGUILLO TRIM	TRIM HOSE	TUBO TRIM
5	REC17-44166	17-44166	EJE SUJECCIÓN TRIM	ANCHOR PIN	ASSE TRIM
6	REC32-864589	32-864589	LATIGUILLO TRIM	TRIM HOSE	TUBO TRIM
7	REC32-864588	32-864588	LATIGUILLO TRIM	TRIM HOSE	TUBO TRIM
8	REC85060	85060	SUJECCIÓN TUBO	PLATE	SUPPORTO TUBO
9	REC10-85486	10-85486	TORNILLO	SCREW	VITE
10	REC17-44167A1	17-44167A1	EJE SUJECCIÓN TRIM	ANCHOR PIN	ASSE SUPPORTO TUBO
11	REC53-805272	53-805272	ARO RETENEDOR	RETAINING RING	ANELLO BLOCCANTE
12	REC12-44164	12-44164	ARANDELA	WASHER	RONDELLA
13	REC23-807073	23-807073	ADAPTADOR GOMA P.T.	P.T. RAM BUSHING	ADATTATORE GOMMA
14	REC12-44163	12-44163	ARANDELA	WASHER	RONDELLA
15	REC11-34933	11-859116	TUERCA INOX	LOCK NUT	DADO INOX
16	REC8M0080805	8M0080805	KIT CONECTOR	TRIM CONNECTOR KIT	CONNETTORE
17	REC98703A26	98703A26	PISTÓN TRIM BABOR	TRIM CYLINDER PORT	PISTONE TRIM SINISTRO
18	REC98704A26	98704A26	PISTÓN TRIM ESTRIBOR	TRIM CYLINDER STBD	PISTONE TRIM DESTRO
19	REC32-861127	32-861127	LATIGUILLO TRIM NEGRO (-OW099999)	TRIM HOSE BLACK (-OW099999)	TUBO TRIM NEGRO (-OW099999)
20	REC32-861128	32-861128	LATIGUILLO TRIM GRIS (-OW099999)	TRIM HOSE GRAY (-OW099999)	TUBO TRIM GRIGIO (-OW099999)
21	REC19-14842	19-14842	TAPA PLÁSTICO	PLASTIC CAP	COPERCHIO IN PLASTICA

## LATIGUILLOS POWER TRIM POWER TRIM HOSES TUBI POWER TRIM

REF.	R.O. OEM	CONECTOR FITTING CONNETTORI	LARGO LONG LUNGHEZZA
REC32-864960	32-99902-1 32-864960	1/8"	11 <sup>1/2</sup> " + 14"
REC32-864589	32-99902 32-864589	1/8"	11 <sup>1/2</sup> " + 14"

MOTORES / ENGINES / MOTORI  
MCM 120-260 & BRAVO

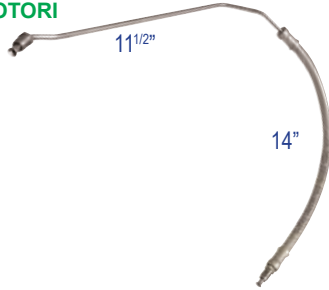

REF.	R.O. OEM	CONECTOR FITTING CONNETTORI	LARGO LONG LUNGO
REC32-864959	32-99903-1 32-864959	1/8"	11 <sup>1/2</sup> " + 14"
REC32-864588	32-99903 32-864588	1/8"	11 <sup>1/2</sup> " + 14"

MOTORES / ENGINES / MOTORI  
MCM 120-260 & BRAVO  
1/8"

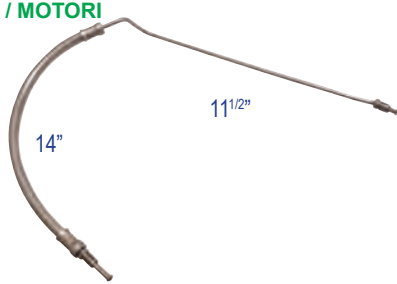

REF.	R.O. OEM	CONECTOR FITTING CONNETTORI	LARGO LONG LUNGO
REC32-87234	32-87234	1/8"	11 <sup>1/2</sup> " + 14"

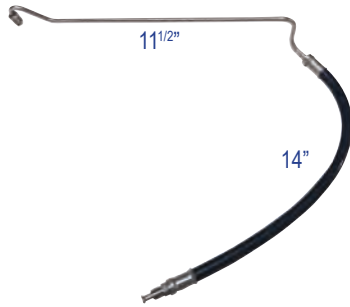

REF.	R.O. OEM	CONECTOR FITTING CONNETTORI	LARGO LONG LUNGO
REC32-87235	32-87235	1/8"	11 <sup>1/2</sup> " + 14"

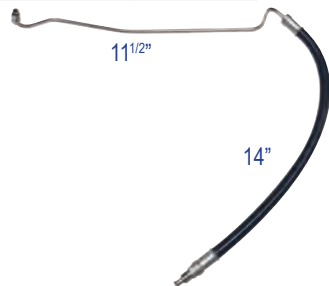

REF.	R.O. OEM	CONECTOR FITTING CONNETTORI	LARGO LONG LUNGO
REC32-86036	32-86036 32-86036Q	1/8"	14"



REF.	R.O. OEM	CONECTOR FITTING CONNETTORI	LARGO LONG LUNGO
REC32-861127	32-861127 32-95858	■ 1/8"	46"
REC32-861128	32-861128 32-95859	■ 1/8"	51"

MOTORES / ENGINES / MOTORI

R / MR / ALPHA GEN II / BRAVO I, II, III /  
BRAVO X, XR, XZ  
(-OW099999)

sin conectores rápidos  
without quick connect fittings  
senza connettori rapidi

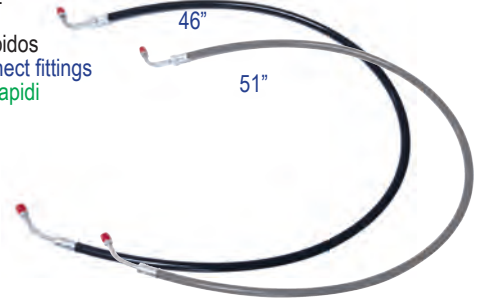

REF.	R.O. OEM	CONECTOR FITTING CONNETTORI	LARGO LONG LUNGO
REC32-99904	32-99904	1/8"	15"

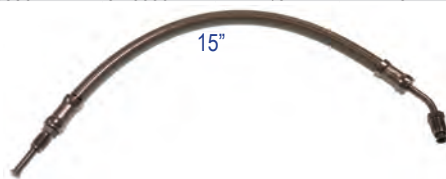

REF.	R.O. OEM	CONECTOR FITTING CONNETTORI	LARGO LONG LUNGO
REC32-55816	32-55816	1/8"	21"



REF.	R.O. OEM	CONECTOR FITTING CONNETTORI	LARGO LONG LUNGO
REC32-59841	32-59841	1/8"	51"



REF.	R.O. OEM	CONECTOR FITTING CONNETTORI	LARGO LONG LUNGO
REC32-59842	32-59842	1/8"	32"



REF.	R.O. OEM	CONECTOR FITTING CONNETTORI
REC32-58432A2	32-58432A2	■



# CARBURADORES CARBURETORS CARBURATORI

## CARBURADORES REMANUFACTURADOS REBUILT CARBURETORS CARBURATORI RIGENERATI

### ROCHESTER

Ref.	R.O. OEM	CUERPOS BBL CORPI
REC3304-9354A2	3304-9354A2	4
	1347-804623R1	
	1347-804623R02	

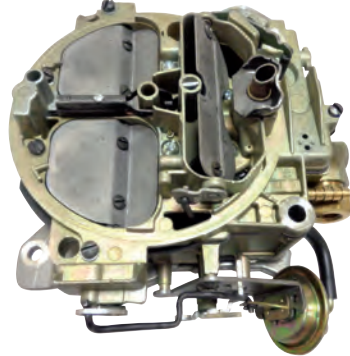

### ROCHESTER

Ref.	R.O. OEM	CUERPOS BBL CORPI
REC1347-9661A3	1347-9661A3	4
	1347-8296A4	
	1347-7361A1	
	1347-7364A1	

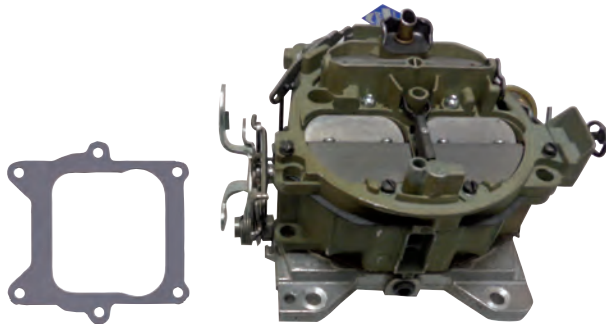

### ROCHESTER

Ref.	R.O. OEM	CUERPOS BBL CORPI
REC804626R02	1347-8288A1	4
	1347-804626R1	
	804626R02	
	1347-6493A1	
	1347-8291A3	
	1347-7363A1	
1347-7366A		



### ROCHESTER

Ref.	R.O. OEM	CUERPOS BBL CORPI
REC982217	1347-818620	2
	1347-818620R02	
	1351-7355A1	
	1347-8186201	
	1351-4032A1	
1351-5203A1		

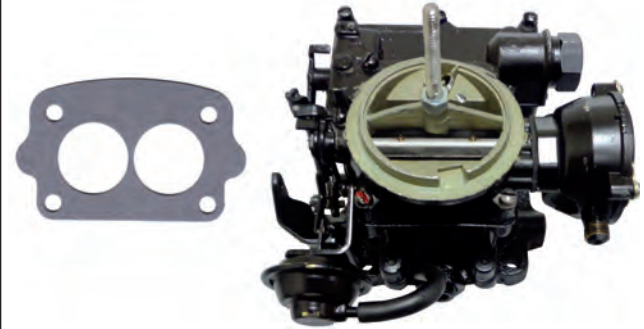

### ROCHESTER

Ref.	R.O. OEM	CUERPOS BBL CORPI
REC1348-818621R02	1348-818621	2
	1348-818621R02	
	1347-8186211	
	1347-818621R02	
	1351-8480A2	

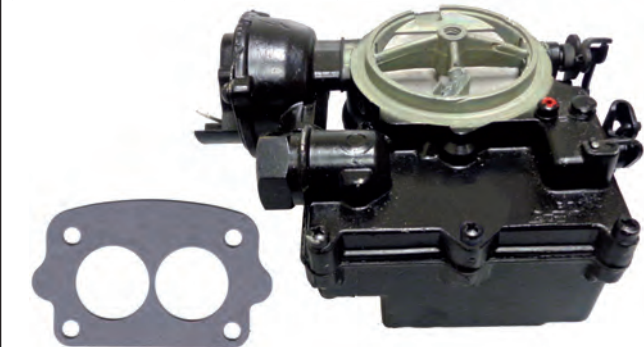

### ROCHESTER

Ref.	R.O. OEM	CUERPOS BBL CORPI
REC1376-818622R02	1376-818622R02	2
	1347-818622	
	1376-5659A1	
	1347-8186221	
	1376-5744A1	
	1376-6152A1	



## ROCHESTER

Ref.	R.O. OEM	CUERPOS	
		BBL	CORPI
REC1347-818619R02	1347-818619	2	
	1347-818619R02		
	1347-8186191		
	1351-4263A1		
	1351-7354A1		
	1336-3594A1		
	1351-4263A2		
	1351-4263A3		
	1351-5202A1		
	1351-6065A2		



## ROCHESTER

Ref.	R.O. OEM	CUERPOS	
		BBL	CORPI
REC3310-807312A1	3310-807312A1	2	
	3310-807312R02		
	1389-9670A2		



## WEBER (CARTER)

Ref.	R.O. OEM	CUERPOS	
		BBL	CORPI
REC807262R02	3310-806969A1	4	
	807262R02		
	3310-8M0047212		
	3310-806969R01		

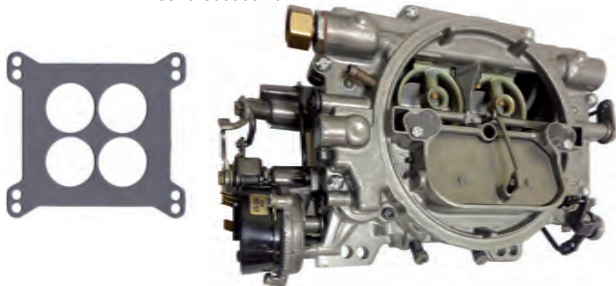

## CARBURADORES NUEVOS NEW CARBURETORS CARBURATORI NUOVI

### HOLLEY

Ref.	R.O. OEM	CUERPOS	
		BBL	CORPI
MP426422		2	

**MOTORES / ENGINES / MOTORI**  
4.3L  
500 CFM



### HOLLEY

Ref.	R.O. OEM	CUERPOS	
		BBL	CORPI
MP426574		4	

**MOTORES / ENGINES / MOTORI**  
5.7 L  
600 CFM

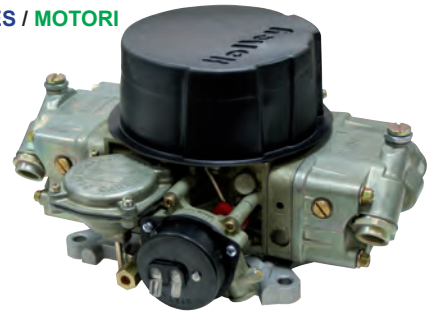

### HOLLEY

Ref.	R.O. OEM	CUERPOS	
		BBL	CORPI
MP426434		4	

**MOTORES / ENGINES / MOTORI**  
4.3 L  
600 CFM



### HOLLEY

Ref.	R.O. OEM	CUERPOS	
		BBL	CORPI
MP426766		4	

**MOTORES / ENGINES / MOTORI**  
7.4 L  
750 CFM

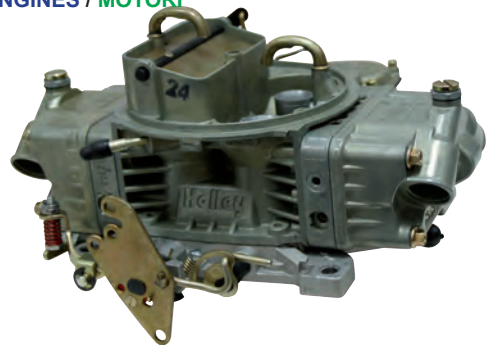

### WEBER, EDELBROCK, CARTER AFB

Ref.	R.O. OEM	CUERPOS	
		BBL	CORPI
REC9-34081		4	

**MOTORES / ENGINES / MOTORI**  
V8 750 CFM  
Reemplaza la mayoría de carburadores.  
Replaces most carburetors.  
Sostituisce la maggior parte dei carburatori.

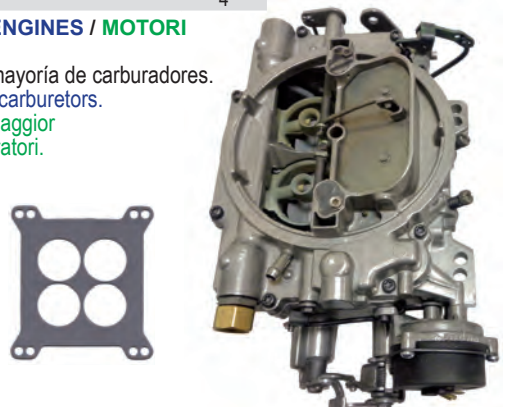

**TKS**

Ref.	R.O. OEM	CUERPOS BBL CORPI
REC3310-866143A03	3310-866143A03	2

**MOTORES / ENGINES / MOTORI**  
5.7L  
0M600000 - 0W300009  
0W300010+

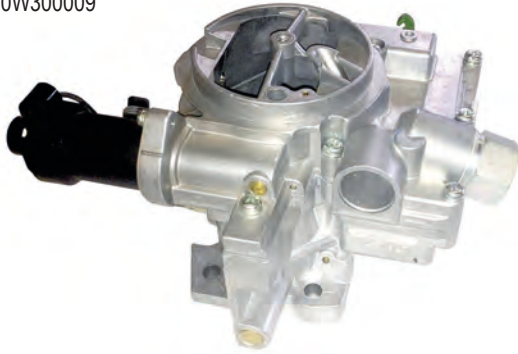

**MERCARB**

Ref.	R.O. OEM	CUERPOS BBL CORPI
REC3310-864943A01	3310-864943A01 3310-861245A1	2

**MOTORES / ENGINES / MOTORI**  
5.7 GM350 V8 (1998-01)  
5.7 CARB ALPHA BRAVO  
5.7 CARB MIE  
5.7 CARB SKY  
5.7 COMPETITION SKI (GEN+) GM 350 V8 (1998)  
5.7L  
1998+

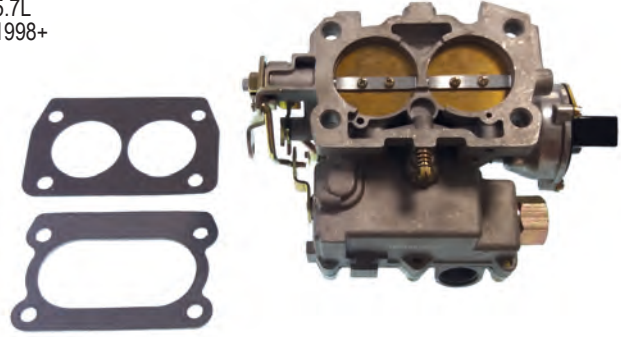

**Q-JET**

Ref.	R.O. OEM	CUERPOS BBL CORPI
REC1347-816373A4	1347-816373A4 1347-804624R02 3310-804624R1 1347-6492A1 1347-7362A1 1347-8292A4 1347-9662A4 1347-9415T	4

**MOTORES / ENGINES / MOTORI**  
MCM 260, 350 MAG, 5.0L, 5.0LX,  
5.7. (1982 - 95)



**MERCARB**

Ref.	R.O. OEM	CUERPOS BBL CORPI
REC3310-864942A01	3310-864942A01 3310-861448A1	2

**MOTORES / ENGINES / MOTORI**  
5.0L ALPHA/BRAVO (-0M623982)  
5.0L ALPHA/BRAVO (0M623983+)  
5.0L (1998-04)

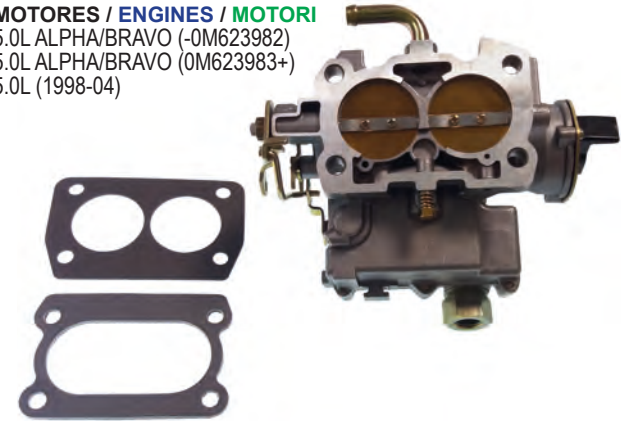

**KITS ADAPTADORES CARBURADOR  
CARBURETOR ADAPTER KITS  
KIT ADATTATORE CARBURATORI**

**KIT ADAPTADOR CARBURADOR HOLLEY  
HOLLEY CARBURETOR ADAPTER KIT  
KIT ADATTATORE CARBURATORE HOLLEY**

Ref.	R.O. OEM
RECHOL17-6	

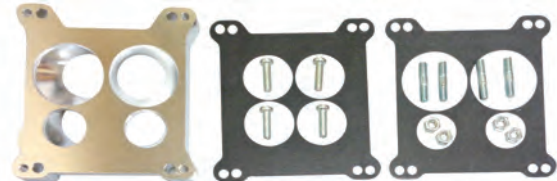

**MERCARB**

Ref.	R.O. OEM	CUERPOS BBL CORPI
REC3310-864941A01	3310-864941A01	2

**MOTORES / ENGINES / MOTORI**  
4.3L (2002-04)  
(0M615000-0W300012)

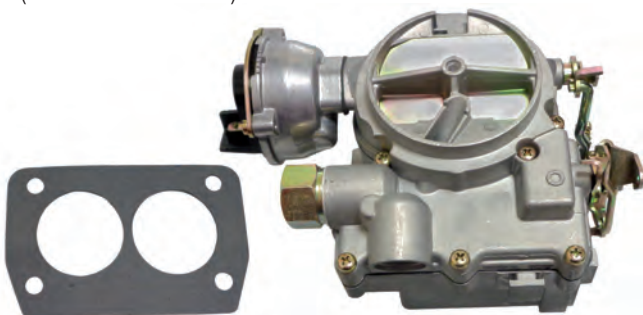

**KIT ADAPTADOR CABLE MCM A HOLLEY  
MCM TO HOLLEY ADAPTER CABLE KIT  
KIT ADATTATORE CAVI MCM A HOLLEY**

Ref.	R.O. OEM
RECHOL717-7	



**TUBO COMBUSTIBLE BOMBA  
A CARBURADOR  
FUEL TUBE FROM PUMP  
TO CARBURETOR  
TUBO DA COMBUSTIBILE A  
POMPA CARBURATORI**

Ref.	R.O. OEM	ROSCA THREAD PASO
REC18-8115		3/8" x 25 - 5/8"
REC18-8114		3/8" x 31" - 5/8"



**KITS TORNILLOS CARBURADOR  
CARBURETORS SCREW KITS  
KITS VITI CARBURATORI**

Ref.	R.O. OEM	ROSCA THREAD PASO
REC9-35176		1 3/8" - 5/16"



**BOYAS  
FLOATS  
GALLEGGIANTI**

**ROCHESTER**

Ref.	R.O. OEM	CUERPOS BBL CORPI
REC1397-2060	1397-2060	2



**ROCHESTER**

Ref.	R.O. OEM	CUERPOS BBL CORPI
REC1397-3327	1397-3327	4
	1397-8546	
	1397-8959	



**ROCHESTER & MERCAB**

Ref.	R.O. OEM	CUERPOS BBL CORPI
REC3302-9031	1397-5837 3302-9031	2



**WEBER**

Ref.	R.O. OEM	CUERPOS BBL CORPI
REC811536T	811536T 811536	4



**WEBER**

Ref.	R.O. OEM	CUERPOS BBL CORPI
REC1397-2610	1397-2610	



**KIT AGUJAS  
INLET NEEDLE KIT  
KIT AGHI**

**WEBER**

Ref.	R.O. OEM
REC823727	823727

**MOTORES / ENGINES / MOTORI**  
V6



**WEBER**

Ref.	R.O. OEM
REC811534	811534

**MOTORES / ENGINES / MOTORI**  
V8



**MERCAB**

Ref.	R.O. OEM
REC3302-804689	3302-804689

**MOTORES / ENGINES / MOTORI**  
Moderno  
New style  
Modello moderno

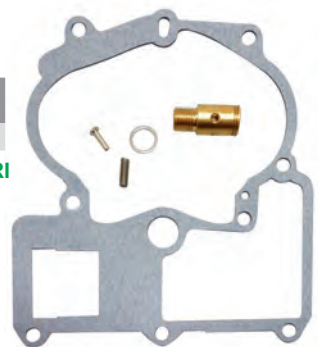

Ref.	R.O. OEM
REC3302-9407	3302-9407

**MOTORES / ENGINES / MOTORI**  
Antiguo  
Old style  
Modello vecchio



**JUNTAS CARBURADOR  
CARBURETORS GASKETS  
GUARNIZIONE CARBURATORI**

Ref.	R.O. OEM
REC27-48399	27-48399

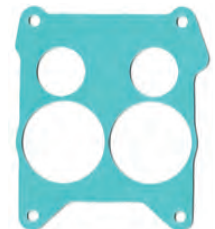

Ref.	R.O. OEM
REC27-805396	27-805396

**MOTORES / ENGINES / MOTORI**  
5.7L & 7.4L MPI



**HOLLEY**

Ref.	R.O. OEM	CUERPOS BBL CORPI
REC27-65577	27-65577	4
REC27-12732	27-12732	4
REC27-41609	27-41609	4
REC27-70142	27-70142	2
REC27-60715	27-60715	2

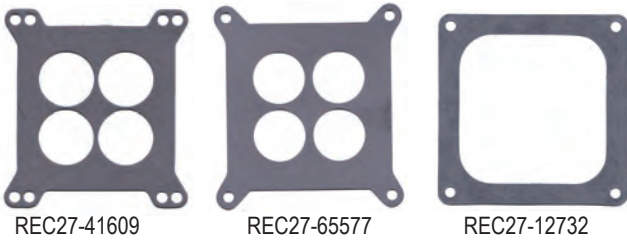

**ROCHESTER**

Ref.	R.O. OEM	CUERPOS BBL CORPI
REC27-64692	27-64692	4
REC27-58764	27-58764	2



**ROCHESTER & WEBER**

Ref.	R.O. OEM	CUERPOS BBL CORPI
REC27-524572	27-524572	4
REC27-8079821	8079821	2



**KITS CARBURADORES  
CARBURETORS KITS  
KIT CARBURATORI**

Ref.	R.O. OEM
REC823427A1	823427A1
	1397-8873
	1397-8872
	1397-7547
	1397-7542
	1397-3459
	1397-2634
	1397-2067



Ref.	R.O. OEM
REC1397-6367A1	1397-6367A1

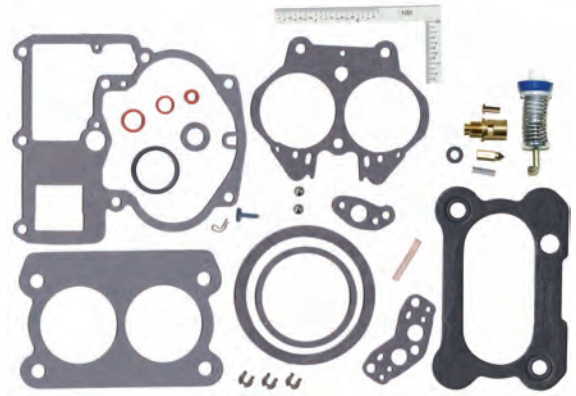

Ref.	R.O. OEM
REC1397-8760	1397-8760
	1397-5830
	1397-7099



Ref.	R.O. OEM
REC1398-3089	1398-3089
	1346-2770



Ref.	R.O. OEM
REC1397-3458	1397-3458



Ref.	R.O. OEM
REC1396-4656	1396-4656

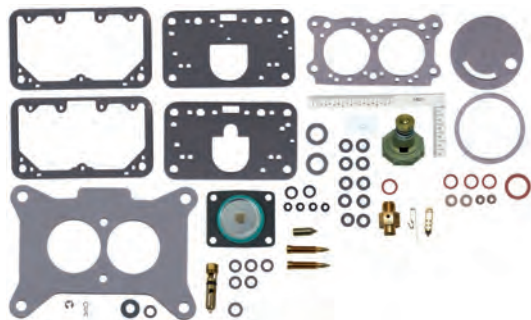

Ref.	R.O. OEM
REC13220	13220

**MOTORES / ENGINES / MOTORI**

GM420 V8 (87-89) GM465 V8 502 (90-92)  
 GM425 V8 454 (90-93) GM465 Gen-V 502 V8 (92-94)  
 GM425 Gen-V V8 454 (92-93) 500 Gen+ GM502 V8 (1999)  
 GM440 TRS 454 (83-86) 500 Gen V 502 V8 (94-98)  
 GM450 V8 454 (95-96) 500 Bulldog 540 V8 (90-01)  
 GM460 TRS V8 482 (83-86)

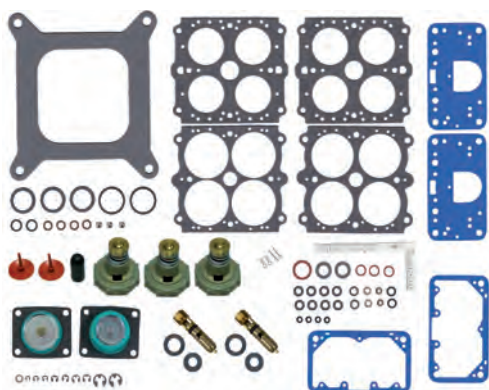

**WEBER**

Ref.	R.O. OEM	CUERPOS BBL CORPI
REC809064	809064	4
REC809065	809065	4
	835076	
	823728	

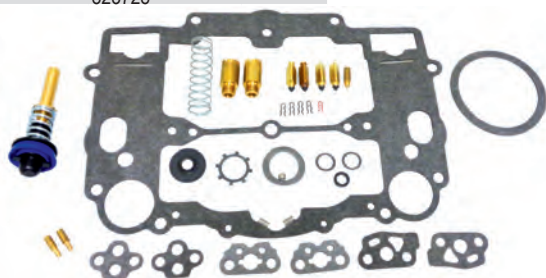

**MERCAB**

Ref.	R.O. OEM
REC3302-804845	3302-9437
	3302-804845



Ref.	R.O. OEM
REC3302-804844002	3302-804844002

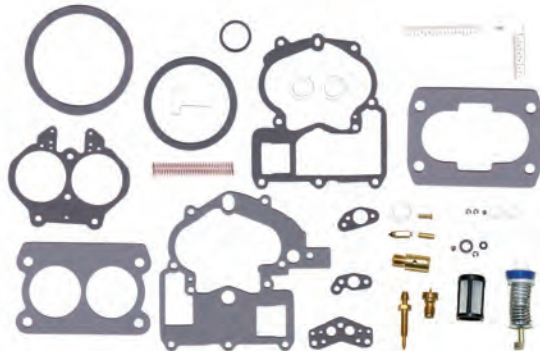

**FORD**

Ref.	R.O. OEM
REC1396-5238	1396-5238
	1396-5222

**MOTORES / ENGINES / MOTORI**

FORD 351, (1970-74)

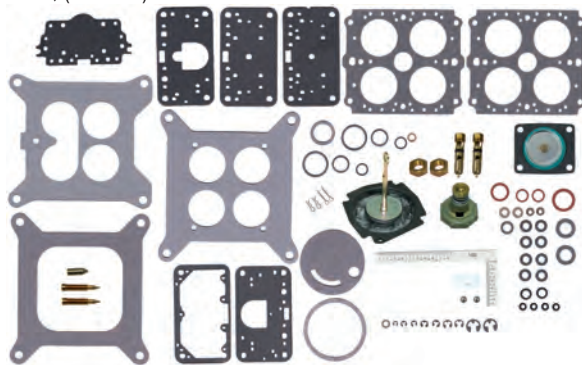

**FORD + ROCHESTER**

Ref.	R.O. OEM
REC1397-5831	1397-5831

**MOTORES / ENGINES / MOTORI**

(1970-77)



**ROCHESTER**

Ref.	R.O. OEM	CUERPOS BBL CORPI
REC823426A1	823426A1	4

**MOTORES / ENGINES / MOTORI**

FORD 351, (1970-74)

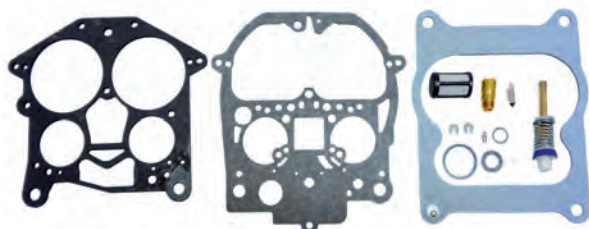









## APAGALLAMAS FLAME ARRESTORS PARAFIAMMA

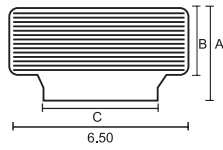

Ref.	R.O. OEM	A	B	C	MOTOR ENGINE MOTORE
REC861259	861259	6.04	3.94	9.40	
REC805016A1	805016A1	6.20	4.00	7.80	4 & 6 Cyl.
REC85785A2	85785A2	5.71	3.73	12.83	V8
REC85784A1	85784A1	5.48	2.76	7.93	4 & 6 Cyl.
REC805298A1	85785T 805298A1	5.71	3.73	12.83	V8



REC861259



REC805016A1

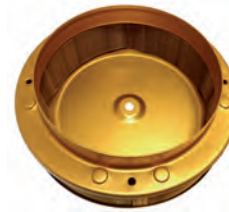

REC805298A1



REC85784A1



REC85785A2

## INYECTORES INJECTORS INIETTORI

Ref.	R.O. OEM
REC802632T	802632T 802632

**MOTORES / ENGINES / MOTORI**  
MCM/MIE 7.4L  
MPI (L29)



Ref.	R.O. OEM
REC881693002	881693002

**MOTORES / ENGINES / MOTORI**  
MCM 496 Mag &  
HO, MIE 8.1S & HO



Ref.	R.O. OEM
REC885176	885176

**MOTORES / ENGINES / MOTORI**  
MCM/MIE 4.3L MPI,  
5.0L MPI, 350 Mag MPI,  
MX 6.2L MPI engines  
w/ECM555



Ref.	R.O. OEM
REC3858941	852956A1

**MOTORES / ENGINES / MOTORI**  
MCM GM V6 & V8 (305 & 350 cid) TBI

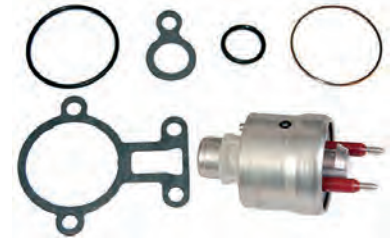

### KIT RETENES INYECTOR FUEL INJECTOR SEAL KIT KIT PARAOLI INIETTORI

Ref.	R.O. OEM
REC9-33306	881693 881693002

**MOTORES / ENGINES / MOTORI**  
881693 on MCM 496 Mag  
& HO, MIE 8.1S & HO



Ref.	R.O. OEM
REC9-33304	802632T 849896

**MOTORES / ENGINES / MOTORI**  
802632T & 849896  
MCM/MIE 7.4L  
MPI (L29)



Ref.	R.O. OEM
REC9-33301	885176

**MOTORES / ENGINES / MOTORI**  
885176 MCM/MIE  
4.3L, 5.0L, 350 Mag MPI,  
MX 6.2L w/ECM 555



Ref.	R.O. OEM
REC9-33300	806807A1

**MOTORES / ENGINES / MOTORI**  
806807A1  
Ski 350 Mag MPI & Blk Scorpion Ski  
(OF350583-OK040000)



Ref.	R.O. OEM
REC9-33302	861260T 861260

**MOTORES / ENGINES / MOTORI**  
861260T 350 Mag MPI (1998+)  
MX 6.2L MPI,  
7.4L/502 Mag MPI (1999+) 8.2L MPI



Ref.	R.O. OEM
REC853998A1	853998A1 851956A1 853998T 853998

**MOTORES / ENGINES / MOTORI**  
852956A1  
MCM GM  
V-6 & V-8 (305 & 350) TBI



Ref.	R.O. OEM
REC9-33303	805225A1

**MOTORES / ENGINES / MOTORI**  
805225A1 MCM/MIE Ski  
GM V-8 350, 377, 454, 502 MPI



## SENSORES SENDERS SENSORI

### SENSOR MAP MAP SENSOR SENSORE MAP

Ref.	R.O. OEM
REC8M0054726	881731 8M0054726

**MOTORES / ENGINES / MOTORI**  
V6 & V8 MPI con / with / con 555 ECM



Ref.	R.O. OEM
REC854445	854445

**MOTORES / ENGINES / MOTORI**  
MCM 525 EFI



Ref.	R.O. OEM
REC3850396	864856A1 805217A1

**MOTORES / ENGINES / MOTORI**  
MCM/MIE GM V-6 & 350, 377, MX 6.2L  
MPI, 7.4L MPI, 454, 502 EFI



Ref.	R.O. OEM
REC861249A1	861249A1 861249

**MOTORES / ENGINES / MOTORI**  
MCM/MIE GM V-6 & 305, 350, MX 6.2L  
MPI, 7.4L MPI (1998+)  
5.0L, 5.7L EFI (1998)



Ref.	R.O. OEM
REC879150150	879150150 849934

**MOTORES / ENGINES / MOTORI**  
MCM 575SC1



### SENSOR MAT / MAP MAT / MAP SENSOR SENSORE MAT / MAP

Ref.	R.O. OEM
REC8M0087834	885165 8M0087834

**MOTORES / ENGINES / MOTORI**  
350MAG MPI  
377MAG MPI  
383MAG STROKER  
4.3L MPI  
5.0L MPI  
5.7L MPI  
6.2L MPI



### SENSOR "PICK UP" PICK UP SENSOR SENSORE "PICK UP"

Ref.	R.O. OEM
REC3854001	811639 811639T

**MOTORES / ENGINES / MOTORI**  
V4 / V6 / V8  
Delco Voyager



### SENSOR DE TEMPERATURA AIRE AIR TEMPERATURE SENSOR SENSORE TEMPERATURA ARIA

Ref.	R.O. OEM
REC805223T	805223T 805223

**MOTORES / ENGINES / MOTORI**  
V6 & V8 (350, 454, 496 & 502 CID)  
EFI / MPI  
500, 520, 525, 540,  
575 (Race sterndrive)



**SENSOR DE PICADO**  
**KNOCK SENSOR**  
**SENSORE DI CADUTA**

Ref.	R.O. OEM
REC8M0077616	805544T 8M0077616

**MOTORES / ENGINES / MOTORI**  
454, 502, 540, 572  
7.4L, 454 MAGNUM 8.2L  
500, 525, 575, 600, 800 (Race sterndrive)

Ref.	R.O. OEM
REC806612T	806612T

**MOTORES / ENGINES / MOTORI**  
MCM/MIE 305, 350, 377 GM V8 CID



**SENSOR POSICION DE GAS**  
**THROTTLE POSITION SENSOR**  
**SENSORE POSIZIONE FARFALLA**

Ref.	R.O. OEM
REC853678T	853678T 853678

**MOTORES / ENGINES / MOTORI**  
MCM/MIE 4.3L,  
5.0L, MX 6.2L w/ECM555,  
350 Mag MPI, Blk Scorpion  
Ski, 7.4L MPI (L29), MCM  
496 Mag & HO, 8.1S & HO



Ref.	R.O. OEM
REC803148	803148

**MOTORES / ENGINES / MOTORI**  
MCM/MIE 350 Mag, Blk  
Scorpion Ski  
(0L005900 & +)



Ref.	R.O. OEM
REC805226A1	805226A1

**MOTORES / ENGINES / MOTORI**  
MCM/MIE V-6 & 305,  
350, 454, 502 EFI



**SENSOR POSICION ARBOL DE LEVAS**  
**CAMSHAFT SENSOR**  
**SENSORE POSIZIONE ASSE A CAMME**

Ref.	R.O. OEM
REC3863130	898141

**MOTORES / ENGINES / MOTORI**  
3.0, 4.3, 5.0, 5.7, 6.2L  
Se instala en distribuidor  
Is installed in distributor  
Viene installato nello spinterogeno



**SENSOR CAUDAL AGUA**  
**WATER SENSOR**  
**SENSORE ACQUA**

Ref.	R.O. OEM
REC8M6000623	8M6000623 881879010 8818793

**MOTORES / ENGINES / MOTORI**  
V6 & V8  
4.5L MPI



**SENSOR POSICION CIGÜEÑAL**  
**CRANKSHAFT POSITION SENSOR**  
**SENSORE POSIZIONE ALBERO MOTORE**

Ref.	R.O. OEM
REC892617	892617

**MOTORES / ENGINES / MOTORI**  
8.1L  
496 Mag, H.O. BRAVO



Ref.	R.O. OEM
REC892615002	892615002 892615001 892615

**MOTORES / ENGINES / MOTORI**  
MCM 496 Mag, 8.1 Inboard



Ref.	R.O. OEM
REC864297T01	864297T01 864297 864297001

**MOTORES / ENGINES / MOTORI**  
350 Magnum, 377 Magnum MPI,  
5.0L MPI, 5.7L MPI, 6.2L MPI,  
8.2L MPI  
4.3L CARB / MPI  
525, 600, 662, 700 (Race sterndrive)



**SENSOR TEMPERATURA ENFRIADOR**  
**COOLANT TEMPERATURE SENDER**  
**SENSORE TEMPERATURA SCAMBIATORE**

Ref.	R.O. OEM
REC3850397	805218T 805218

**MOTORES / ENGINES / MOTORI**  
350 MAG ,PI  
383 MAG  
4.3L MPI, 5.0L MPI, 3.0L MPI  
6.2L MPI  
357, 377  
4.3 CARB, EFI  
454, 496 MAG, EFI  
5.7L CARB, EFI  
8.1, 8.2L MIE



**SENSOR TEMPERATURA AGUA**  
**WATER TEMPERATURE SENDER**  
**SENSORE TEMPERATURA ACQUA**

Ref.	R.O. OEM
REC97258A1	97258A1 97258 34625 F16900198 F16900152



Ref.	R.O. OEM
REC806490T	806490T 97257A1 97-257 806490 811091 36525



Ref.	R.O. OEM
REC48952	48952



**KIT TEMPERATURA Y PRESIÓN  
DE ACEITE CON ALARMA**  
**COMPLETE TEMPERATURE & OIL  
PRESSURE WARNING KIT**  
**KIT TEMPERATURA PRESSIONE  
DELL'OLIO CON ALLARME**

Ref.	R.O. OEM
REC41400	

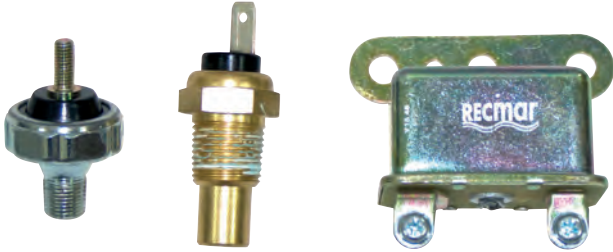

**SENSOR ACEITE PARA BOMBA  
COMBUSTIBLE**  
**ELECTRIC FUEL PUMP SWITCH SENSOR**  
**SENSORE OLIO PER POMPA  
COMBUSTIBILE**

Ref.	R.O. OEM
REC87-864252	87-864252

**MOTORES / ENGINES / MOTORI**

4.3, 5.0, 5.7  
Motores modernos  
Later engines  
Motori moderno



Ref.	R.O. OEM
REC87-864252A01	87-864252A01

**MOTORES / ENGINES / MOTORI**

4.3, 5.0, 5.7  
Motores antiguos  
Old engines  
Motori vecchio



**SENSOR IAC  
IAC SENDER  
SENSORE IAC**

Ref.	R.O. OEM
REC3855194	805224A1

**MOTORES / ENGINES / MOTORI**

MCM/MIE GM V-6 & 305,  
350, 454, 502 EFI  
500, 575 (Race sterndrive)



Ref.	R.O. OEM
REC803149	803149

**MOTORES / ENGINES / MOTORI**

MCM/MIE 350 Mag MPI  
Black Scorpion Ski, 377 Scorpion,  
MCM & Ski MX  
6.2L MPI, 7.4L MPI  
(L29), 575SCi



**VALVULA DE AIRE, IAC  
AIR VALVE, IDLE  
VALVOLA ARIA**

Ref.	R.O. OEM
REC862998	862998

**MOTORES / ENGINES / MOTORI**

3.0L MPI, 4.3 MPI, 5.0L MPI,  
350 MAG MPI,  
MX6.2 MPI,  
8.1L  
600, 662, 700 (Race sterndrive)



**SENSOR PRESIÓN DE ACEITE  
OIL PRESSURE SENDER  
SENSORE PRESIONE OLIO**

Ref.	R.O. OEM	HILO THREAD FILO	TERMINAL
REC8M0068784	87-815425T	1/8 - 27	10 - 31
	8M0068784		
	90806		
	815425 34623		



Ref.	R.O. OEM
REC87-805605A1	87-805605A1

**MOTORES / ENGINES / MOTORI**

3.0L (1990-95)  
4.3L (1993-98)  
5.0L (1988-01)  
5.7L (1988-01)  
7.4L (1991-00)



**REGULADORES PRESIÓN  
DE COMBUSTIBLE**  
**FUEL PRESSURE REGULATORS**  
**REGOLATORI PRESSIONE  
CARBURANTE**

Ref.	R.O. OEM
REC802630T01	802630T01
	802630001
	802630T
	802630
	8M0069803

**MOTORES / ENGINES / MOTORI**

MCM/MIE 7.4L MPI (L29) 496 Mag, 8.1L  
Se monta en la línea de enfriador de combustible.  
Mounts on fuel rail  
Si monta nello scambiatore di calore.



Ref.	R.O. OEM
REC849899	849899

**MOTORES / ENGINES / MOTORI**

MCM 500 EFI (Race sterndrive)  
Se instala en el "fuel rail"  
Mounts on fuel rail  
E "installato nel "fuel rail"



Ref.	R.O. OEM
REC807952A1	807952A1

**MOTORES / ENGINES / MOTORI**  
MCM/MIE GM V-6, V-8 305, 350, 377 EFI/MPI,  
MCM 575SCi  
Se monta en la linea de enfriador de combustible.  
(marca rosa)  
Mounts on fuel rail (pink mark)  
Si monta nella linea dello scambiatore di calore  
della benzina. (colore rosa)



Ref.	R.O. OEM
REC892681	892681

**MOTORES / ENGINES / MOTORI**  
5.0L MPI, 5.7L MPI, 350 Magnum,  
6.2L MPI, 496 Magnum, 8.1L, 8.2L,  
502 Mag MPI, 375HP, 425HP.  
520, 540 (Race sterndrive)  
Se instala en la tapa del módulo.  
Is installed in module cover.  
Viene installato nel coperchio del modulo



Ref.	R.O. OEM
REC861126A1	861126A1

**MOTORES / ENGINES / MOTORI**  
MCM 4.3 MPI, 5.0 MPI, 350 Magnum, 8.1 L, 6.2  
MPI, 7.4 MPI.  
Seguir la marca de la base del tubo, marron azul/  
verde. Se instala en el enfriador de combustible.  
Mounts on fuel cooler. Brown & blue/green mark  
on base of tube  
Da montare su motori con tubo con colore  
marrone blu/verde. Si monta nella linea dello  
scambiatore di calore di benzina



Ref.	R.O. OEM
REC885174	885174

**MOTORES / ENGINES / MOTORI**  
4.3L, 5.0L, 5.7L & 6.2L MPI  
Con 555 ECM en linea combustible. Se  
instala en el "fuel rail"  
With 555 ECM in fuel rail. Mounts on fuel rail  
Con 555 ECM in lineadel carburante  
E "installato nel "fuel rail"



Ref.	R.O. OEM
REC860349A1	860349A1

**MOTORES / ENGINES / MOTORI**  
MCM/MIE 7.4L/LX MPI, 454 Mag MPI, 502  
Mag MPI, MIE 8.2L MPI  
Se monta en el enfriador de combustible (sin  
marca de color)  
Mounts on fuel cooler (no color mark)  
Si monta nella linea dello scambiatore di  
calore della benzina. (senza codice colore)



Ref.	R.O. OEM
REC805227A1	805227A1

**MOTORES / ENGINES / MOTORI**  
MCM/MIE 7.4L/LX MPI,  
454 & 502 Mag MPI,  
8.2L MPI  
Se instala en el "fuel rail"  
Mounts on fuel rail  
E "installato nel "fuel rail"



## GUÍA DE SENSORES SENSOR APPLICATION GUIDA SENSORI GUIDA SENSORI

MODELO MODEL MODELLO	CID / CYL	YEAR ANO ANNO	SERIE SERIAL SERIE	INYECTOR INJECTOR INNIETTORE	KIT INYECTOR INJECTOR KIT KIT INNIETTORE	IAC VÁLVULA IAC VALVE IAC VALVOLA	TPS	REGULADOR PRESIÓN RAIL REGULATOR PRESSURE RAIL REGOLATORE PRESSIONE RAIL	REGULADOR PRESION COOLER REGULATOR PRESSURE COOLER REGOLATORE PRESSIONE COOLER	MAP	PICADO KNOCK BATTITO	TEMP. AIRE AIR TEMP. IAT MAT TEMP. ARIA
262 MAG EFI	262/V6	96-97	OF803800-OK999999		REC3858941	REC3855194	REC805226A1		REC807952A1	REC3850396		
4.3L EFI	262/V6	98-01	OL012009-OM299999		REC3858941	REC3855194	REC805226A1		REC807952A1	REC861249A1		REC805223T
4.3L MPI	262/V6	02/07	OM300000+	REC885176	REC9-33301	REC862998	REC853678T	REC885174	REC807952A1			REC3850397
5.0L EFI	305/V8	98-01	OL012052-OM299999		REC853998A1	REC3855194	REC805226A1		REC807952A1	REC861249A1		REC805223T
5.0L MPI	305/V8	02-07	OM300000+	REC885176	REC9-33301	REC862998	REC853678T	REC885174	REC861126A1			
5.0L MPI DTS	305/V8	05-07	OW310000+	REC885176	REC9-33301			REC885174				
320 EFI	350/V8	87-89	OA543604-OC622418			REC862998						
350 Mag Alpha EFI (gen+)	350/V8	96-97	OF800300-OK999999		REC853998A1	REC3855194	REC805226A1		REC807952A1	REC3850396	REC806612T	
350 Mag Bravo MPI	350/V8	95-96	OF415189-OK001500			REC3855194	REC805226A1	REC806808A2		REC3850396	REC806612T	
350 Mag Bravo MPI (gen+)	350/V8	97	OK001501-OK999999		REC9-33303	REC3855194	REC805226A1		REC807952A1	REC3850396	REC806612T	
350 Mag EFI Ski	350/V8	94-96	OF215561-OF820706		REC853998A1	REC3855194	REC805226A1			REC3850396	REC806612T	
350 Mag EFI Ski	350/V8	1996	OF820707-OK040005		REC853998A1	REC3855194	REC805226A1		REC807952A1	REC3850396	REC806612T	
350 Mag EFI Ski	350/V8	1997	OK040006-OK999999		REC853998A1	REC3855194	REC805226A1		REC807952A1	REC3850396	REC806612T	
350 Mag MPI	350/V8	1998	OL010019-OL331598		REC9-33302	REC803149	REC853678T		REC807952A1	REC861249A1	REC806612T	
350 Mag MPI	350/V8	1998	OL336000-OL346999		REC9-33302	REC803149	REC853678T		REC807952A1	REC861249A1	REC806612T	
350 Mag MPI	350/V8	1999	OL331599-OL335999		REC9-33302	REC803149	REC803148		REC807952A1	REC861249A1	REC806612T	REC805223T
350 Mag MPI	350/V8	99-01	OL340000-OM299999		REC9-33302	REC803149	REC803148		REC807952A1	REC861249A1	REC806612T	REC805223T
350 Mag MPI	350/V8	02-07	OM300000+	REC885176	REC9-33301	REC862998	REC853678T	REC885174	REC861126A1			
350 Mag MPI DTS	350/V8	05-07	OW310000+	REC885176	REC9-33301			REC885174				
350 Mag MPI Horizon	350/V8	02-07	OM300000+	REC885176	REC9-33301	REC862998	REC853678T	REC885174	REC861126A1			
350 Mag MPI Horizon DTS	350/V8	05-07	OW310000+	REC885176	REC9-33301			REC885174				
350 Mag MPI Horizon MIE	350/V8	99-01	OL304700-OM299999		REC9-33302	REC803149	REC803148		REC807952A1	REC861249A1	REC806612T	
350 Mag MPI Horizon MIE	350/V8	02-04	OM300000-OM398371	REC885176	REC9-33301	REC862998	REC853678T		REC861126A1			



MODELO MODEL MODELLO	CID / CYL	YEAR ANO ANNO	SERIE SERIAL SERIE	INYECTOR INJECTOR INNIETORE	KIT INYECTOR INJECTOR KIT KIT INNIETORE	IAC VÁLVULA IAC VALVE IAC VALVOLA	TPS	REGULADOR PRESIÓN RAIL REGULATOR PRESSURE RAIL REGOLATORE PRESSIONE RAIL	REGULADOR PRESION COOLER REGULATOR PRESSURE COOLER REGOLATORE PRESSIONE COOLER	MAP	PICADO KNOCK BATTITO	TEMP. AIRE AIR TEMP. IAT MAT TEMP. ARIA
350 Mag MPI Horizon MIE	350/V8	04-07	OM398372+	REC885176	REC9-33301	REC862998	REC853678T	REC885174				
350 Mag MPI Horizon MIE DTS	350/V8	05-07	OW310000+	REC885176	REC9-33301			REC885174				
350 Mag MPI MIE	350/V8	1998	OL002008- OL304999		REC9-33302	REC803149	REC853678T		REC807952A1	REC861249A1	REC806612T	
350 Mag MPI MIE	350/V8	02-04	OM300000- OM398371	REC885176	REC9-33301	REC862998	REC853678T	REC885174	REC861126A1			
350 Mag MPI MIE	350/V8	04-07	OM398372+	REC885176	REC9-33301	REC862998	REC853678T	REC885174				
350 Mag MPI MIE DTS	350/V8	05-07	OW310000+	REC885176	REC9-33301			REC885174				
350 Mag EFI Ski	350/V8	94-96	OF215561- OF820706		REC853998A1	REC3855194	REC805226A1			REC3850396	REC806612T	
350 Mag MPI Ski	350/V8	1998	OL002600- OL304599		REC9-33302	REC803149	REC853678T		REC807952A1	REC861249A1	REC806612T	
350 Mag MPI Ski	350/V8	99-01	OL304600- OM299999		REC9-33302	REC803149	REC803148		REC807952A1	REC861249A1	REC806612T	
350 Mag MPI Ski	350/V8	02-07	OM300000+	REC885176	REC9-33301	REC862998	REC853678T	REC885174	REC861126A1			
5.7L EFI	350/V8	95-97	OF225560- OK999999		REC853998A1	REC3855194	REC805226A1		REC807952A1	REC3850396	REC806612T	
5.7L EFI (Gen+)	350/V8	98-01	OL010035- OM299999		REC853998A1	REC3855194	REC805226A1		REC807952A1	REC861249A1	REC806612T	REC805223T
5.7L EFI (Gen+)	350/V8	1997	OK040300- OK999999		REC853998A1	REC3855194	REC805226A1		REC807952A1	REC3850396	REC806612T	
5.7LX Bravo EFI (Gen+)	350/V8	96-97	OF800300- OK999999		REC853998A1	REC3855194	REC805226A1		REC807952A1	REC3850396	REC806612T	
5.7LX EFI	350/V8	95-97	OF225560- OK999999		REC853998A1	REC3855194	REC805226A1		REC807952A1	REC3850396	REC806612T	
Black Scorpion Ski	350/V8	1996	OF350583- OK040000			REC803149	REC853678T	REC885174		REC3850396	REC806612T	
Black Scorpion Ski	350/V8	1997	OK040001- OL002699		REC9-33303	REC803149	REC853678T		REC807952A1	REC3850396	REC806612T	
Black Scorpion Ski	350/V8	1998	OL002700- OL005600		REC9-33303	REC803149	REC853678T		REC807952A1		REC806612T	
Black Scorpion Ski	350/V8	98-05	OL005601- OM391599		REC9-33303	REC803149	REC803148		REC807952A1		REC806612T	
Black Scorpion Ski	350/V8	03-07	OM391600+		REC9-33303	REC862998	REC803148		REC807952A1			
377 Scorpion MCM	377/V8	99-05	OL416146- OM907201		REC9-33303	REC803149	REC803148		REC807952A1	REC3850396	REC806612T	
377 Scorpion Ski	377/V8	97-98	OK000656- OL600314		REC9-33303	REC803149	REC853678T		REC807952A1	REC3850396	REC806612T	
MX 6.2L MPI	377/V8	00-01	OL68003- OM299999		REC9-33302	REC803149	REC803148		REC807952A1	REC861249A1	REC806612T	REC805223T
MX 6.2L MPI	377/V8	02-04	OM300000- OW059999	REC885176	REC9-33301	REC862998	REC853678T	REC885174	REC861126A1			
MX 6.2L MPI	377/V8	04-07	OW060000+	REC885176	REC9-33301	REC862998	REC853678T	REC885174				
MX 6.2 MPI DTS	377/V8	05-07	OW310000+	REC885176	REC9-33301			REC885174				
MX 6.2L MPI Horizon	377/V8	02-04	OM300000- OW059999	REC885176	REC9-33301	REC862998	REC853678T	REC885174	REC861126A1			
MX 6.2L MPI Horizon	377/V8	04-07	OW060000+	REC885176	REC9-33301	REC862998	REC853678T	REC885174				
MX 6.2L MPI Horizon DTS	377/V8	05-07	OW310000+	REC885176	REC9-33301	REC862998		REC885174				
MX 6.2L MPI Horizon MIE	377/V8	02-04	OM300000- OM398394	REC885176	REC9-33301	REC862998	REC853678T	REC885174	REC861126A1			
MX 6.2L MPI Horizon MIE	377/V8	04-07	OM398395+	REC885176	REC9-33301	REC862998	REC853678T	REC885174				
MX 6.2L MPI Horizon MIE DTS	377/V8	05-07	OW390000+	REC885176	REC9-33301			REC885174				
MX 6.2L MPI MIE	377/V8	02-04	OM300000- OM398394	REC885176	REC9-33301	REC862998	REC853678T	REC885174	REC861126A1			
MX 6.2L MPI MIE	377/V8	04-07	OM398395+	REC885176	REC9-33301	REC862998	REC853678T	REC885174				
MX 6.2L MPI MIE DTS	377/V8	05-07	OW390000+	REC885176	REC9-33301	REC862998		REC885174				
MX 6.2L MPI Ski	377/V8	02-07	OM317000+	REC885176	REC9-33301	REC862998	REC853678T	REC885174	REC861126A1			
MX 6.2L Black Scorpion Ski	377/V8	01-03	OL005601- OM391599		REC9-33303	REC803149	REC803148		REC807952A1		REC806612T	
MX 6.2L Black Scorpion Ski	377/V8	03-07	OK391750+		REC9-33303	REC862998	REC803148		REC807952A1			
454 Mag EFI	454/V8	94-96	OF115700- OF802349		REC9-33303	REC3855194	REC805226A1	REC805227A1		REC3850396	REC8M0077616	REC805223T
454 Mag EFI Ski	454/V8	94-96	OF215800- OF820099		REC9-33303	REC3855194	REC805226A1	REC805227A1	REC3850396	REC8M0077616	REC805223T	
454 Mag EFI Ski	454/V8	96-97	OF820099- OK999999		REC9-33303	REC3855194	REC805226A1	REC805227A1	REC3850396	REC8M0077616		
454 Mag MPI	454/V8	96-97	OF802350- OK147349		REC9-33303	REC3855194	REC805226A1	REC805227A1	REC3850396	REC8M0077616	REC805223T	
454 Mag MPI	454/V8	96-97	OK147350- OL085399		REC9-33303	REC3855194	REC805226A1	REC805227A1	REC860349A1	REC3850396	REC8M0077616	
454 Mag MPI	454/V8	97-98	OL085400- OM024999		REC9-33302	REC3855194	REC805226A1		REC861126A1	REC3850396	REC8M0077616	
454 Mag MPI Horizon MIE	454/V8	99-01	OL002200- OL086049		REC9-33303	REC3855194	REC805226A1	REC805227A1	REC860349A1	REC3850396	REC8M0077616	
454 Mag MPI Horizon MIE	454/V8	1998	OL086050- OL674000		REC9-33302	REC3855194	REC805226A1		REC861126A1	REC3850396	REC8M0077616	
74.L MPI (L29)	454/V8	99-01	OL010003- OM024330	REC802632T	REC9-33304	REC803149	REC853678T	REC802630T01	REC861126A1	REC861249A1	REC8M0077616	REC805223T
7.4L MPI MIE	454/V8	98-01	OF503052- OK147349		REC9-33303	REC3855194	REC805226A1	REC805227A1		REC3850396	REC8M0077616	REC805223T
7.4L MPI MIE	454/V8	95-96	OK147350- OK999999		REC9-33303	REC3855194	REC805226A1	REC805227A1	REC860349A1	REC3850396	REC8M0077616	
7.4L MPI MIE (L29)	454/V8	1997	OL010003- OL674613	REC802632T	REC9-33304	REC803149	REC805226A1	REC802630T01	REC861126A1	REC861249A1	REC8M0077616	REC805223T

MODELO MODEL MODELLO	CID / CYL	YEAR ANO ANNO	SERIE SERIAL SERIE	INYECTOR INJECTOR INNIETTORE	KIT INYECTOR INJECTOR KIT KIT INNIETTORE	IAC VÁLVULA IAC VALVE IAC VALVOLA	TPS	REGULADOR PRESIÓN RAIL REGULATOR PRESSURE RAIL REGOLATORE PRESSIONE RAIL	REGULADOR PRESIÓN COOLER REGULATOR PRESSURE COOLER REGOLATORE PRESSIONE COOLER	MAP	PICADO KNOCK BATTITO	TEMP. AIRE AIR TEMP. IAT MAT TEMP. ARIA
7.4LX TBI	454/V8	98-01	OF820000-OK999999			REC3855194	REC805226A1		REC807952A1	REC3850396	REC8M0077616	
7.4LX MPI	454/V8	96-97	OF602010-OK147349		REC9-33303	REC3855194	REC805226A1	REC805227A1		REC3850396	REC8M0077616	REC805223T
7.4Lx MPI	454/V8	1996	OK147350-OK999999		REC9-33303	REC3855194	REC805226A1	REC805227A1	REC860349A1	REC3850396	REC8M0077616	REC805223T
496 Mag	496/V8	1997	OM025000-OW059999	REC881693002	REC9-33306	REC862998	REC853678T	REC802630T01	REC861126A1			
496 Mag	496/V8	01-04	OW060000+	REC881693002	REC9-33306	REC862998	REC853678T	N.S.S.	REC892681	REC8M0054726		
496 Mag DTS	496/V8	04-07	OM025000-OW059999	REC881693002	REC9-33306			REC802630T01	REC861126A1			
496 Mag DTS	496/V8	01-04	OW060000+	REC881693002	REC9-33306			N.S.S.		REC8M0054726		
496 Mag HO	496/V8	04-07	OM025000-OW059999	REC881693002	REC9-33306	REC862998	REC853678T	REC802630T01	REC861126A1			REC805223T
496 Mag HO	496/V8	01-04	OW060000+	REC881693002	REC9-33306	REC862998	REC853678T	N.S.S.		REC8M0054726		REC805223T
496 Mag HO DTS	496/V8	04-07	OM025000-OW059999	REC881693002	REC9-33306			REC802630T01	REC861126A1			REC805223T
496 Mag HO DTS	496/V8	01-04	OW060000+	REC881693002	REC9-33306			N.S.S.		REC8M0054726		REC805223T
8.1L MIE	496/V8	04-07	OM026000-OW059999	REC881693002	REC9-33306	REC862998	REC853678T	REC802630T01	REC861126A1			REC805223T
8.1L MIE	496/V8	01-04	OW090000+	REC881693002	REC9-33306	REC862998	REC853678T	N.S.S.	REC892681	REC8M0054726		REC805223T
8.1L HO MIE	496/V8	04-07	OM026000-OW089999	REC881693002	REC9-33306	REC862998	REC853678T	REC802630T01	REC861126A1			REC805223T
8.1L HO MIE	496/V8	01-04	OW090000+	REC881693002	REC9-33306	REC862998	REC853678T	N.S.S.	REC892681	REC8M0054726		REC805223T
500 EFI	502/V8	04-07	OL001477+		REC9-33304	REC3855194		REC849899	REC861126A1	REC3850396	REC8M0077616	
502 Mag MPI	502/V8	99-05	OD840650-OK147349		REC9-33303	REC3855194	REC805226A1	REC805227A1		REC3850396	REC8M0077616	
502 Mag MPI	502/V8	93-96	OK147350-OL085432		REC9-33303	REC3855194	REC805226A1	REC805227A1	REC860349A1	REC3850396	REC8M0077616	REC805223T
502 Mag MPI	502/V8	97-98	OL085432-OM024999		REC9-33302	REC3855194	REC805226A1		REC861126A1	REC3850396	REC8M0077616	REC805223T
525 EFI	502/V8	99-01	OM900146+		REC9-33303		REC805226A1		REC861126A1	REC854445		
575 Sci	502/V8	03-07	OL306696-OM950526			REC3855194	REC805226A1		REC807952A1	REC879150150	REC8M0077616	REC805223T
8.2 MPI MIE	502/V8	00-05	OF819620-OK147349		REC9-33303	REC3855194	REC805226A1	REC805227A1		REC3850396	REC8M0077616	
8.2 MPI MIE	502/V8	1996	OK127350-OL086012		REC9-33303	REC3855194	REC805226A1	REC805227A1	REC860349A1	REC3850396	REC8M0077616	
8.2 MPI MIE	502/V8	97-98	OL086013-OL674200		REC9-33303	REC3855194	REC805226A1		REC861126A1	REC3850396	REC8M0077616	

## BOMBAS COMBUSTIBLE ELÉCTRICAS ELECTRIC FUEL PUMPS & KIT POMPE BENZINA ELETTRICHE

Ref.	R.O. OEM
REC861155A6	861155A6
	861155A5
	805656A6
	805656A2
	805656A5
	805025A2

### MOTORES / ENGINES / MOTORI

4.3L V-6.

Sustituye modelos antiguos.

Replaces old models.

Sostituzione vecchi modelli.



Ref.	R.O. OEM
REC861155A3	861155A3
	861155A2

### MOTORES / ENGINES / MOTORI

4.3, 5.0 / 5.7, 8.1L V6 & V8



Ref.	R.O. OEM
REC866170A01	866170A01

### MOTORES / ENGINES / MOTORI

305, 350, 377 & 496 CID

GM V-8 con módulo de baja presión Gen III.

GM V-8 with Gen III cool fuel module low pressure.

Con modulo di bassa pressione Gen III.



Ref.	R.O. OEM
REC866169T01	866169T01
	866169A01

### MOTORES / ENGINES / MOTORI

305, 350, 377, 496

5.0, 5.7, 6.2, 8.1, 8.2, 6.2L

Con regulador for GM V-8 con módulo de alta presión Gen III.

With regulator for GM V-8 with Gen III cool fuel module high pressure.

Con regulatore. Con modulo ad alta pressione Gen III.



**KIT BOMBA COMBUSTIBLE  
FUEL PUMP KIT  
KIT POMPA BENZINA**

Ref.	R.O. OEM
REC827682T	827682T 827682



**MOTORES / ENGINES / MOTORI**

- |   |                     |
|---|---------------------|
| 262 MAG (TBI) (GEN+)                      | OF803800 - OK999999 |
| 350 MAG EFI SKY (TBI) GM350 V-8 1994-1996 | OF215561 - OF820706 |
| 350MAG MPI SKY GM350 V-8 1995-1996        | OF350583 - OF799999 |
| 350 MAG ALPHA EFI (GEN+) GM350 V-8 1996   | OF800300 - OK001508 |
| 350 MAG BRAVO MPI GM350 V-8 1995          | OF415189 - OF601999 |
| 350 MAG BRAVO MPI (GEN+) GM350 V-8 1996   | OF602000 - OK001500 |
| 5.7L ALPHA EFI (TBI) GM350 V-8 1995       | OF355305 - OF752389 |
| 5.7L BRAVO (TBI) GM350 V-8 1995           | OF225560 - OF752399 |
| 5.7L EFI (2BBL-TBI) GM350 V-8 1996        | OF752400 - OK001505 |
| 5.7LX BRAVO EFI (GEN+) GM350 V-8 1996     | OF800300 - OK001508 |
| 5.7LX EFI (4BBL-TBI) GM350 V-8 1996       | OF752400 - OK001505 |



**BOMBA DE COMBUSTIBLE  
BAJA PRESIÓN  
LOW PRESSURE FUEL PUMP  
POMPA BENZINA BASSA PRESSIONE**

Ref.	R.O. OEM
CARP74021	

**MOTORES / ENGINES / MOTORI**

12 Volt.  
4-6PSI /20-30 GPH  
Poseen todas las medidas de seguridad exigidas. Puede usarse para trasvase de gasoil.  
Listed by Marine Division UL. Used for diesel fuel transfer  
Conforme con tutte le misure di sicurezza necessarie. Si può utilizzare per travasi di gasolio.



Ref.	R.O. OEM
REC3858261	805656A2
	805656A5
	805025A2
	861155A5
	805656A6
	861155A6

**MOTORES / ENGINES / MOTORI**

V6 - V8  
Modelo antiguo  
Old Model  
Modello vecchio  
4.3Fi & Carbureted 1992-93  
Bomba eléctrica en línea.  
Inline electric pump model.  
Pompa elettrica in linea.  
8 PSI, 25gpm



**BOMBA DE COMBUSTIBLE  
ALTA PRESIÓN  
HIGH PRESSURE FUEL PUMP  
POMPA BENZINA ALTA PRESSIONE**

Ref.	R.O. OEM
REC861156A1	861156A1

**MOTORES / ENGINES / MOTORI**

350 Mag M.P.I. Alpha/Bravo/Horizon/MIE/Ski  
4.3L EFI/Gen+ TBI/M.P.I. Alpha/Bravo-454 Mag M.P.I. Bravo & Horizon  
5.0/5.7L EFI/M.P.I. Alpha/Bravo-502 Mag M.P.I.  
7.4L M.P.I. Bravo & MIE 8.1L/8.2L MIE M.P.I.  
MX6.2L M.P.I. Alpha/Bravo/Horizon & MIE Black Scorpion  
Scorpion 377 Stendrive Racing  
(Sin rosca) Reemplaza la bomba de combustible fría  
(non threaded) Replaces cool fuel pump  
(Non filettato) Sostituisce la pompa del carburante fresco



**KIT BOMBA DE COMBUSTIBLE BAJA  
PRESIÓN  
LOW PRESSURE FUEL PUMP KIT  
KIT POMPA BENZINA BASSA  
PRESSIONE**

Ref.	R.O. OEM
RECEFP-KT	



**KIT JUNTAS SEPARADOR VAPOR  
VAPOR SEPARATOR TANK O-RING  
KIT GUARNIZIONI SEPARATORE  
VAPORE**

Ref.	R.O. OEM
REC808500	808500



**BOMBA COMBUSTIBLE  
Y KIT ENFRIADOR  
ELECTRIC FUEL PUMP & COOLER  
POMPA BENZINA E KIT SCAMBIATORE**

Ref.	R.O. OEM
REC861156A04	861156A04

**MOTORES / ENGINES / MOTORI**  
(#807950)  
MPI, EFI & TB  
V6 & V8  
(-0K999999)



Ref.	R.O. OEM
REC861156A03	861156A03

**MOTORES / ENGINES / MOTORI**  
(#865356)  
4.3 MPI, 5.0 MPI, 350 MAG MPI, MX6.2 MPI  
OM300000+

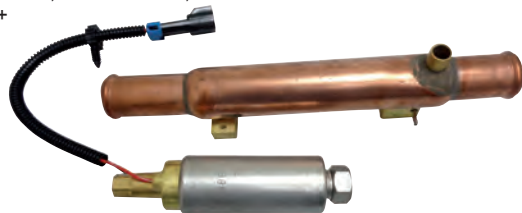

**BOMBAS COMBUSTIBLE MECÁNICAS  
MECHANIC FUEL PUMPS  
POMPA BENZINAMECCANICHE**

Ref.	R.O. OEM	FILTRO FILTER FILTRO	JUNTA GASKET GUARNIZIONE
REC862077A1	41141A2 862077A1	REC35-8M0046752	REC27-34213

**MOTORES / ENGINES / MOTORI**  
V6; 231, 262, 229

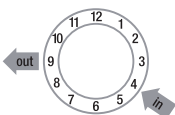

Ref.	R.O. OEM
REC86246T	86246T 86246 86246A1 78485 71646

**MOTORES / ENGINES / MOTORI**  
V8; 305, 350, 400, 228, 250, 255, 260, 280

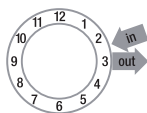

Ref.	R.O. OEM
REC62092T	62092T 62092 54552

**MOTORES / ENGINES / MOTORI**  
Ford V8 302

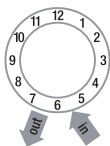

Ref.	R.O. OEM
REC86247T	86247T 86247 86247A2 78820 63196 46860

**MOTORES / ENGINES / MOTORI**  
V8; 454 / 330, 325, 350, 390

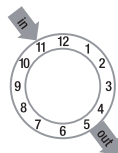

Ref.	R.O. OEM
REC862048A1	812454A1 812454A3 97399A2 862048A1 97399

**MOTORES / ENGINES / MOTORI**  
V8; 305, 350, 454, 330, 420  
Inline (4 cyl) 120, 140, 3.0L & 224 CID

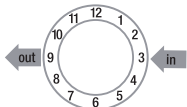

Ref.	R.O. OEM	FILTRO FILTER FILTRO
REC86234A4	86234A4 8623405 86234A3 86234 77594 71327 47585	REC35-49088A2

**MOTORES / ENGINES / MOTORI**  
GM (4 & 6 cyl) 153, 181, 225, 250, 120  
/ 140 / 160 / 165 / 470 / 185 / 488

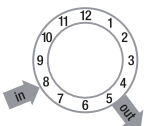

Ref.	R.O. OEM	FILTRO FILTER FILTRO
REC8M0073435	8M0073435 861676T09 861676A1 842725A3	REC35-8M0046752

**MOTORES / ENGINES / MOTORI**  
GM 4 cyl (2.5 / 3.0L) MCM 3.7L  
3.0L (SNL097000+)

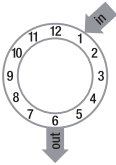

Ref.	R.O. OEM
REC8M0058164	8M0058164 97401

**MOTORES / ENGINES / MOTORI**  
GM V8 305, 350, 228 / 230 / 260 / 898

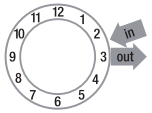

Ref.	R.O. OEM
REC861677T	861677T 818383T

**MOTORES / ENGINES / MOTORI**  
GM V8 (454 & 502)

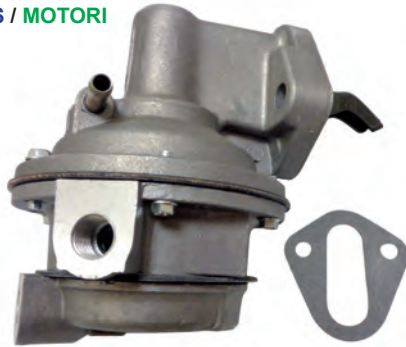
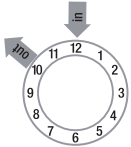

**JUNTAS  
GASKETS  
GUARNIZIONI**

Ref.	R.O. OEM
REC27-34213	27-34213
REC27-42457	27-42457
REC27-72805	27-72805
REC27-34898	27-34898



REC27-72805



REC27-34898



REC27-42457



REC27-34213

**GUÍA BOMBAS MECÁNICAS  
MECHANIC PUMPS APPLICATION  
GUIDA POMPE MECCANICHE**

MODELO MODEL MODELLO	SERIE SERIAL SERIE	REF
120	1666601- 3377340	REC86234A4
120	-4469866	REC86234A4
120	4469866 - 4952700	REC86234A4
120	4952701+	REC86234A4
120	5192049 - 6229717	REC86234A4
120/2.5L	6229718+	REC86234A4
120/2.5L	6229718+	REC8M0073435
140 (4 Cil.)	2508261 - 3332137	REC86234A4
140	-4460664	REC86234A4
140	4460665-4918569	REC86234A4
140	4918570+	REC86234A4
140 (4 Cil.)	5157669 - 6229717	REC86234A4
140/3.0L	6229718+	REC86234A4
140/3.0L	6229718+	REC8M0073435
3.0L/3.0LX	C856559+	REC8M0073435
160	2048022 - 2770031	REC86234A4
165	4471566 - 4884834	REC86234A4
165	5178959+	REC86234A4
165/3.7-LX (4 Cil.)	6916779+	REC8M0073435
170 (4 Cil.)	6916779+	REC8M0073435
180/3.7-LX (4 Cil.)	6916779+	REC8M0073435
175/4.3L (262 CID)	B527955+	REC862077A1
185 (229 CID)	6330183+	REC862077A1
185 (262 CID)	A331455+	REC862077A1
190 (4 Cil.)	6916779+	REC8M0073435
200	2453769 - 2712072	REC86234A4
200 GM	6218462+	REC8M0058164
200/5.0L GM	B525982+	REC8M0058164
205 (262 CID)	A331455+	REC862077A1
205/4.3L-LX (262 CID)	B527955+	REC862077A1
215 Ford	-3085036	REC62092T
215 Ford	3258182+	REC62092T
225 Ford	3385721+	REC62092T
228 GM	4765100 - 5170008	REC86246T
228 GM	5170009 - 6218461	REC86246T
228 GM	6218462+	REC8M0058164
230 GM Inboard	5907058+	REC8M0058164
230/5.6L-GM (IB)	B522506+	REC8M0058164
230 GM	6218462+	REC8M0058164
230/5.0L-LX GM	B525982+	REC8M0058164
233 Ford	4500860+	REC62092T
255 GM	4768000 - 4908849	REC86246T
255 GM	3258728+	REC62092T
260 GM	4175500 - 5195908	REC86246T
260 GM	5195909+	REC86246T
260/5.7 GM	4908850 - 6218461	REC86246T
260 GM Intraborda	6218461+	REC8M0058164
260/5.7L GM (IB)	B525982+	REC8M0058164
5.7L-GM	5907058+	REC8M0058164
280 GM	5907058+	REC8M0058164
300MR/TRS GM	F025000+	REC8M0058164
325-GM	4176250+	REC86246T
330 GM	6668677+	REC8M0058164

MODELO MODEL MODELLO	SERIE SERIAL SERIE	REF
330 GM/W.B.W.	2278747 - 3640670	REC86247T
340/7.4L-GM (IB)	4623115+	REC86247T
350 GM	6083145+	REC862048A1
350-GM (MAGNUM)	5889914+	REC862048A1
350 (MAG-TOURNEY SKI)	3780450+	REC86247T
370 TRS-GM	A635178+	REC8M0058164
390-GM	D505450+	REC8M0058164
420-GM	6721528+	REC862048A1
425-GM	2781129 - 2825059	REC86247T
454 GM (MAGNUM)	A398941+	REC862048A1
454 MAG. BRAVO GM	A398941+	REC862048A1
470	A631894 +	REC862048A1
470	B840126+	REC862048A1
470	-5097479	REC86234A4

MODELO MODEL MODELLO	SERIE SERIAL SERIE	REF
470	5097480+	REC86234A4
485	5520115 - 6218036	REC86234A4
488	6218037+	REC86234A4
888 Ford	5685394+	REC86234A4
898/198-GM	6170297+	REC86234A4
898 GM	3108723+	REC62092T
5.7 GM (SKI)	4762210 - 6218461	REC86246T
5.7 GM (SKI)	6218462+	REC8M0058164
5.7L BRAVO (GM)350	A338553+	REC8M0058164
7.4L BRAVO GM	B514627+	REC8M0058164
7.4L W/HURTH (IB)	B525982+	REC8M0058164
7.4 BRAVO (Gen V)	B771113+	REC862048A1
7.4 BRAVO (Gen VI)	C391564+	REC862048A1
454 MAG BRAVO MPI (Gen VI) 1996-97		REC861677T

## DISTRIBUIDOR DISTRIBUTOR SPINTEROGENO

### TAPA DISTRIBUIDOR DISTRIBUTOR CAPS CALOTTE SPINTEROGENO

Ref.	R.O. OEM
REC33708	33708

**MOTORES / ENGINES / MOTORI**  
Delco V8



Ref.	R.O. OEM
REC33765T	33765T 33765

**MOTORES / ENGINES / MOTORI**  
Delco 6 Cil



Ref.	R.O. OEM
REC982209	391-5075 391-5075Q1 F16900184

**MOTORES / ENGINES / MOTORI**  
MALLORY V8  
Tapa alta  
High cap  
Calotta alta



Ref.	R.O. OEM
REC835702	392-6318 392-6318T F16900184

**MOTORES / ENGINES / MOTORI**  
Prestolite V8  
Con clip  
with clip  
con clip



Ref.	R.O. OEM
REC392-9086T	392-9086 392-9086T

**MOTORES / ENGINES / MOTORI**  
Prestolite V6



Ref.	R.O. OEM
REC392-9766	392-9766 392-9766Q1 392-9766T F16900185

**MOTORES / ENGINES / MOTORI**  
Prestolite V8  
Con tornillo  
with nut  
con chiusura a vite



Ref.	R.O. OEM
REC393-4988	393-4988 393-3230 393-4988T 393-4988T2

**MOTORES / ENGINES / MOTORI**  
Autolite 8 Cyl



Ref.	R.O. OEM
REC805759Q01	805759Q01 805759A2 805759A1 90746A1 805759A5 805759T2 805759T1 16457A4 805759T2 43557A1 43557

**MOTORES / ENGINES / MOTORI**  
Merc. V8



Ref.	R.O. OEM	ROTOR ROTOR ROTORE
REC3854260	811635T3	REC3854261

**MOTORES / ENGINES / MOTORI**  
Delco 4 cil & 3.0LX



Ref.	R.O. OEM	ROTOR ROTOR ROTORE
REC3854548	808483T3	REC3854549
	808483	
	804483T	
	804418	

**MOTORES / ENGINES / MOTORI**  
Delco V8 E. elect.



Ref.	R.O. OEM	ROTOR ROTOR ROTORE
REC3854331	850484T2	REC3854311
	850484T	
	850484	
	850484	

**MOTORES / ENGINES / MOTORI**  
Delco V6 E. elect.



Ref.	R.O. OEM
REC393-9459Q1	393-9459Q1
	393-3230
	393-4988T
	393-4988T2

**MOTORES / ENGINES / MOTORI**  
Delco 4 Cil



Ref.	R.O. OEM
REC815407A2	815407A2
	13753A2
	815407Q02

**MOTORES / ENGINES / MOTORI**  
Merc. V6



Ref.	R.O. OEM
REC985218	

**MOTORES / ENGINES / MOTORI**  
(1987-90)  
Ford 2.3L  
Con / With / Con: MALLORY DISTRIBUTOR



Ref.	R.O. OEM	ROTOR ROTOR ROTORE
REC898253T23	888731	REC898253013
	898253T23	

**MOTORES / ENGINES / MOTORI**  
4.3L Vortec V6 MPI



Ref.	R.O. OEM	ROTOR ROTOR ROTORE
REC898253T22	884792	REC898253013
	898253T22	

**MOTORES / ENGINES / MOTORI**  
Vortec V8 MPI  
Modernos / late / moderna



## ROTORES ROTORS ROTORI

Ref.	R.O. OEM
REC898253013	898253013
	884790
	8M6001222

**MOTORES / ENGINES / MOTORI**  
Vortec V6 & V8 MPI



Ref.	R.O. OEM
REC8M6001252	898253009
	8M6001252

**MOTORES / ENGINES / MOTORI**  
GM V8 HEI-1998 +  
(excepto/ except / ecceto MPI 555 ECM)



Ref.	R.O. OEM
REC65864	65864
	78016

**MOTORES / ENGINES / MOTORI**  
Autolite V8 Mercury



Ref.	R.O. OEM
REC58217	58217
	898253008
	58217Q
	8M6001251

**MOTORES / ENGINES / MOTORI**  
Delco 4 & 6 Cil



Ref.	R.O. OEM
REC89825302	391-5088
	391-7057
	898253029
	391-7057T
	8M6001224
	F16901224

**MOTORES / ENGINES / MOTORI**  
Mallory V8



Ref.	R.O. OEM
REC834975	392-6326 392-6326T FI6900044

**MOTORES / ENGINES / MOTORI**  
Prestolite V8



Ref.	R.O. OEM
REC3853801	392-9089 392-9767 392-9089T 392-9089Q FI6900186 FI6900190

**MOTORES / ENGINES / MOTORI**  
Presolite V6 & V8



Ref.	R.O. OEM
REC3854549	8M6001253 808484 8084841 898253010

**MOTORES / ENGINES / MOTORI**  
Delco V8 E. eléc.



Ref.	R.O. OEM
REC3854311	850485 8504851 898253012 8M0062084 804424

**MOTORES / ENGINES / MOTORI**  
Delco V6



Ref.	R.O. OEM
REC3854261	811636 8M6001254 8116361 898253011

**MOTORES / ENGINES / MOTORI**  
Delco 4 cil.  
3.0LX



### TRIGGERS (ROTOR + SENSOR) TRIGGERS (ROTOR + SENSOR WHEEL) TRIGGER (ROTORI + SENSORE)

Ref.	R.O. OEM
REC13524A6	13524A6 13524Q06 13524A4 19405A4 90576A4

**MOTORES / ENGINES / MOTORI**  
Merc. V6



Ref.	R.O. OEM
REC13524A1	13524A1 13524T1 13524A5

**MOTORES / ENGINES / MOTORI**  
Merc. V8



### PLATINOS POINTS PUNTINE

Ref.	R.O. OEM
REC8M6001219	392-898253005 392-6325 8M6001219 FI6900031

**MOTORES / ENGINES / MOTORI**  
Prestolite



Ref.	R.O. OEM
REC34235T	34235 34235T

**MOTORES / ENGINES / MOTORI**  
Delco



Ref.	R.O. OEM
REC33700	33700

**MOTORES / ENGINES / MOTORI**  
Delco



Ref.	R.O. OEM
REC58033	58033 898253007

**MOTORES / ENGINES / MOTORI**  
Autolite



Ref.	R.O. OEM
REC71831	87-71831 64850

**MOTORES / ENGINES / MOTORI**  
Mercury



Ref.	R.O. OEM
REC391-5090	391-5090 391-898253004 8M6001250

**MOTORES / ENGINES / MOTORI**  
Mallory



### CONDENSADORES CONDENSERS CONDENSATORI

Ref.	R.O. OEM
REC8M6001249	392-6324 392-898223002 8M6001249 FI6900023 FI6900032 FI6900083 FI6900189

**MOTORES / ENGINES / MOTORI**  
Prestolite V8





Ref.	R.O. OEM
REC33662	33662
	898253003
	6325
	898253005
	33662Q
	8M6001218
	F16900031

**MOTORES / ENGINES / MOTORI**  
Delco 4 & 6 Cil.



Ref.	R.O. OEM
REC64851	81-64851
	58034

**MOTORES / ENGINES / MOTORI**  
Autolite



Ref.	R.O. OEM
REC8M6001217	391-5092
	391-898253001
	391-5093
	8M6001217
	F16900040

**MOTORES / ENGINES / MOTORI**  
Mallory V8,  
Delco 4 & 6 Cil.



Ref.	R.O. OEM
REC33706	33706

**MOTORES / ENGINES / MOTORI**  
Delco V-8



**KITS DE ENCENDIDO  
TUNE UP KITS  
KIT D'ACCENSIONE**

Ref.	R.O. OEM
REC3423A1	34235A1
	34235Q1

**MOTORES / ENGINES / MOTORI**  
Delco 4 & 6 cil.



Ref.	R.O. OEM
REC391-5090Q1	391-5090A1
	391-5090Q1

**MOTORES / ENGINES / MOTORI**  
Mallory V8



Ref.	R.O. OEM
REC801766	801766

**MOTORES / ENGINES / MOTORI**  
Delco V8



Ref.	R.O. OEM
REC801767	801767

**MOTORES / ENGINES / MOTORI**  
Merc. V8



Ref.	R.O. OEM
REC801768	801768

**MOTORES / ENGINES / MOTORI**  
Autolite 8 Cil



Ref.	R.O. OEM
REC392-6324Q1	392-6324A1
	392-6324Q1
	392-6324T1

**MOTORES / ENGINES / MOTORI**  
Prestolite V6 & V8



Ref.	R.O. OEM
REC392-6325Q1	392-6325A1
	392-6325Q1
	392-6325T1

**MOTORES / ENGINES / MOTORI**  
Prestolite V8



**GUÍA KITS DE ENCENDIDO**  
**IGNITION APPLICATION GUIDE**  
**GUIDA KIT ACCENSIONE**

MODELO MODEL MODELLO	CYL	ARRANQUE IGNITION AVVIAMENTO	YEAR AÑO ANNO	SERIE SERIAL SERIE	KIT	PLATINO POINT PUNTINE	CONDENSADOR CONDENSER CONDENSATORE	ROTOR ROTOR ROTORE
110	L-4	Delco	1963-66	1537370-2044033	REC3423A1	REC34235T	REC33662	REC1396-5238
120	L-4	Delco	1964-74	1666601-3825578	REC3423A1	REC34235T	REC33662	REC1396-5238
120/2.5L	L-4	Delco	1974-89	3825579-0C853255	REC3423A1	REC34235T	REC33662	REC1396-5238
140	L-4	Delco	1968-74	2508261-3826282	REC3423A1	REC34235T	REC33662	REC1396-5238
140/3.0L	L-4	Delco	1974-89	3826283-0C856558	REC3423A1	REC34235T	REC33662	REC1396-5238
3.0L/LX	L-4	Prestolite	1990-95	0C856559-0F603999	REC392-6324Q1	REC8M6001219	REC8M6001249	REC3853801
165/3.7L	L-4	Delco	1987-89	0B434940+	REC3423A1	REC34235T	REC33662	REC1396-5238
170	L-4	Delco	1985-86	6916779-0B434940	REC3423A1	REC34235T	REC33662	REC1396-5238
180/3.7LX	L-4	Delco	1987-89	0B436391+	REC3423A1	REC34235T	REC33662	REC1396-5238
180/3.7LX	L-4	Prestolite	1987-89	0B436391+	REC392-6324Q1	REC8M6001219	REC8M6001249	REC3853801
190	L-4	Delco	1985-86	6916779-0B436390	REC3423A1	REC34235T	REC33662	REC1396-5238
470	L-4	Delco	1976-84	4208730-691778	REC3423A1	REC34235T	REC33662	REC1396-5238
485	L-4	Delco	1980-82	5685394-6218036	REC3423A1	REC34235T	REC33662	REC1396-5238
488	L-4	Delco	1983-84	6170297-6916778	REC3423A1	REC34235T	REC33662	REC1396-5238
Todos / All / Tutti Repuesto (4 Cil.)	L-4			Todos / All / Tutti	REC392-6324Q1	REC8M6001219	REC8M6001217	REC3853801
140	L-6	Delco	1963	1538930-1725960	REC3423A1	REC34235T	REC33662	REC1396-5238
150	L-6	Delco	1964-66	1666495-2048046	REC3423A1	REC34235T	REC33662	REC1396-5238
160	L-6	Delco	1967-69	2048022-2494926	REC3423A1	REC34235T	REC33662	REC1396-5238
160	L-6	Delco	1969	2494927-2770031	REC3423A1	REC34235T	REC33662	REC1396-5238
165	L-6	Delco	1971-81	2771484-5813433	REC3423A1	REC34235T	REC33662	REC1396-5238
165	L-6	Delco	1970	2770032-2771483	REC3423A1	REC34235T	REC33662	REC1396-5238
200	L-6	Delco	1969	2453769-2712072	REC3423A1	REC34235T	REC33662	REC1396-5238
Todos / All / Tutti Repuesto (6 Cil.)	L-6			Todos / All / Tutti	REC392-6324Q1	REC8M6001219	REC8M6001249	REC3853801
185 (4 BBL.) (3.8L)	V-6	Prestolite	1983-84	6330183-6919655	REC392-6324Q1	REC8M6001219	REC8M6001249	REC3853801
190 (GM 283)	V-8	Delco	1963-64	1564539-1730903	REC801766	N/D	N/D	N/D
215 MCM y MIE (Ford 302)	V-8	Autolite	1970-72	2781153-3563181	REC801768	REC3302-804844002	REC64851	REC65864
215 MCM y MIE (Ford 302)	V-8	Mallory	1970-72	2781153-3562181	REC391-5090Q1	REC391-5090	REC8M6001217	REC89825302
225 MCM y MIE	V-8	Autolite	1973-74	3385721-4166999	REC801768	REC3302-804844002	REC64851	REC65864
225 MCM y MIE	V-8	Mallory	1973-74	3385721-4166999	REC391-5090Q1	REC391-5090	REC8M6001217	REC89825302
225 MCM y MIE	V-8	Mercury	1973-74	3385721-4166999	REC801767	REC71831	REC64851	REC65864
888 (Ford 302)	V-8	Mercury	1971-77	3108723-4887829	REC801767	REC71831	REC8M6001217	REC65864
888 (Ford 302)	V-8	Prestolite	1971-77	3108723-4887829	REC392-6325Q1	REC8M6001219	REC8M6001249	REC834975
888 (Ford 302)	V-8	Mallory	1971-77	3108723-4887829	REC391-5090Q1	REC391-5090	REC8M6001217	REC89825302
888 (Ford 302)	V-8	Autolite Ign.	1971-77	3108723-4887829	REC801768	REC3302-804844002	REC64851	REC65864
225 (GM 327)	V-8	Delco	1963-69	1539620-2694014	REC801766			
228 MCM y MIE	V-8	Mallory	1977-82	4765100-6218461	REC391-5090Q1	REC391-5090	REC8M6001217	REC89825302
898/198 MCM y MIE	V-8	Mallory	1977-82	4762210-6218461	REC391-5090Q1	REC391-5090	REC8M6001217	REC89825302
233 MCM y MIE	V-8	Mercury	1975-77	4173000-4902304	REC801767	REC71831	REC64851	REC65864
233 MCM y MIE	V-8	Prestolite with	1975-77	4173000-4902304	REC392-6325Q1	REC8M6001219	REC8M6001249	REC834975
233 MCM y MIE	V-8	Prestolite with	1975-77	4173000-4902304	REC392-6324Q1	REC8M6001219	REC8M6001249	REC3853801
250 (GM 350)	V-8	Mallory	1977	4768000-4908849	REC391-5090Q1	REC391-5090	REC8M6001217	REC89825302
255 MIE y MCM (Ford 351)	V-8	Mallory	1973-80	3258728-5907057	REC391-5090Q1	REC391-5090	REC8M6001217	REC89825302
255 MCM y MIE (Ford 351)	V-8	Mercury	1973-80	3258728-5907057	REC801767	REC71831	REC64851	REC65864
255 (GM 350)	V-8	Mallory	1975-76	3258728-4501254	REC391-5090Q1	REC391-5090	REC8M6001217	REC89825302
255 (GM 350)	V-8	Mercury	1976	4498701-4767999	REC801767	REC71831	REC64851	REC65864
260	V-8	Mallory	1978-82	4908850-6128461	REC391-5090Q1	REC391-5090	REC8M6001217	REC89825302
5.7L Ski	V-8	Mallory Ign.	1985-95	0A338533-0F775199	REC391-5090Q1	REC391-5090	REC8M6001217	REC89825302
5.7L Ski	V-8	Prestolite	1985-95	0A338533-0F775199	REC392-6324Q1	REC8M6001219	REC8M6001249	REC3853801
280 TRS	V-8	Mercury	1975	4176250-4499390	REC801767	REC71831	REC64851	REC65864
280 TRS	V-8	Mallory	1976	4499391-4770199	REC391-5090Q1	REC391-5090	REC8M6001217	REC89825302
330 MCM y MIE	V-8	Mallory	1977-81	4623115-6083144	REC391-5090Q1	REC391-5090	REC8M6001217	REC89825302
370 TRS	V-8	Mallory	1978-85	4179554-6721527	REC391-5090Q1	REC391-5090	REC8M6001217	REC89825302
370 TRS	V-8	Holley	1978-85	4883520-6721527	REC801767	REC71831	REC64851	REC65864
400 TRS	V-8	Mallory	1980-86	5668232-0B457644	REC391-5090Q1	REC391-5090	REC8M6001217	REC89825302
400 TRS	V-8	Holley	1980-86	5668232-0B457644	REC801767	REC71831	REC64851	REC65864
440 TRS	V-8	Mallory	1983-86	6181070-0B485220	REC391-5090Q1	REC391-5090	REC8M6001217	REC89825302
440 TRS	V-8	Holley	1983-86	6181070-0B485220	REC801767	REC71831	REC64851	REC65864
460 TRS	V-8	Mallory Ign.	1983-86	6180970-6181046	REC391-5090Q1	REC391-5090	REC8M6001217	REC89825302
460 TRS	V-8	Holley Ign.	1983-86	6180970-6181046	REC801767	REC71831	REC64851	REC65864

## KITS DE CONVERSIÓN ELECTRÓNICO ELECTRONIC CONVERSION KITS KIT DI CONVERSIONE ELETTRICO

- Sustituyen condensadores y contactos por componentes electrónicos.
- Usa bobina, tapa y rotor estandard.
- De fácil instalación, una pieza y dos cables.
- Precisión entre 1/4" calibrado de 0 a 8000 rpm.
- To substitute condensers for electronic devices
- Uses standard coil, cap & rotor
- Easy installation; one piece, two cables.
- Precisely calibrated between 1/4" from 0 to 8000
- Sostituiscce condensatori e contatti per componenti elettronici.
- Utilizza bobina, calotta e rotore standard.
- Facile installazione, una pz e due cavi.
- Precisione 1/4" calibrato da 0 a 8000.

Ref.	R.O. OEM
REC26900	

**MOTORES / ENGINES / MOTORI**  
GM 4 cil.



Ref.	R.O. OEM
REC26904	

**MOTORES / ENGINES / MOTORI**  
Para la mayoría de distribuidores de 8 cilindros Mallory YL o YD con rotación reloj y contrareloj. For most Mallory V8 distributors. Per la maggior parte delli spinterogeni da 8 cil Mallory YL o YD conrotazione std e controrotante.



Ref.	R.O. OEM
REC26903	

**MOTORES / ENGINES / MOTORI**  
Para distribuidores Prestolite V8 con clip en la tapa. For most Prestolite V8 distributors with clip on cap. Per spinterogeni Prestolite V8 con clip nella calotta



Ref.	R.O. OEM
REC26902	

**MOTORES / ENGINES / MOTORI**  
Para la mayoría de distribuidores Prestolite V8 con tornillo en la tapa. For most Prestolite V8 distributors with screw on cap. Per la maggior parte degli spinterogeni Prestolite V8 con vite nella calotta



Ref.	R.O. OEM
REC26901	

**MOTORES / ENGINES / MOTORI**  
Para la mayoría de distribuidores de 6 cilindros Delco. For most Delco 6 cyl. distributors. Per la maggior parte delli spinterogeni da 6 cil Delco.



## GUÍA KITS DE CONVERSIÓN ELECTRÓNICO ELECTRONIC CONVERSION KITS APPLICATION GUIDA KIT DI CONVERSIONE ELETTRICO

MODELO MODEL MODELLO	CYL	ARRANQUE IGNITION AVVIAMENTO	SERIE SERIAL SERIE	DISTRIBUIDOR DISTRIBUTOR DISTRIBUITORE	REF
470R	4	Delco	6218037	Todos / All / Tutti	REC26900
485	4	Delco	5685394	Todos / All / Tutti	REC26900
488R	4	Delco	6170297	Todos / All / Tutti	REC26900
140	6	Delco	1538930 - 1725960	Todos / All / Tutti	REC26901
150	6	Delco	1666495 - 2048046	Todos / All / Tutti	REC26901
160	6	Delco	2048022 - 2770031	Todos / All / Tutti	REC26901
165	6	Delco	2770032	Todos / All / Tutti	REC26901
Alpha 1/120-140	6	Delco	6229718	Todos / All / Tutti	REC26901
200	6	Delco	2453769 - 2712072	Todos / All / Tutti	REC26901
190	8	Delco	1564539 - 1730903	Todos / All / Tutti	
198	8	Mallory	4776402	Excepto / Except / Ecceto YL670AV	REC26904
215	8	Mallory	2781153	Excepto / Except / Ecceto YL670AV	REC26904
225	8	Delco	1539620 - 2694014	Todos / All / Tutti	
225	8	Mallory	3385721	Excepto / Except / Ecceto YL670AV	REC26904
228	8	Mallory	4765100 - 6218461	Excepto / Except / Ecceto YL670AV	REC26904
233	8	Prestolite	4173000	Todos / All / Tutti	REC26903
233	8	Prestolite tornillo bajo tapa	4173000	Todos / All / Tutti	REC26902
198	8	Mallory	4776402	Excepto / Except / Ecceto YL670AV	REC26904
250	8	Mallory	4768000 - 4908849	Excepto / Except / Ecceto YL670AV	REC26904
255	8	Mallory	3258728	Excepto / Except / Ecceto YL670AV	REC26904
260	8	Mallory	4908850 - 6218461	Excepto / Except / Ecceto YL670AV	REC26904
260	8	Mallory intraborda	A338553+	Excepto / Except / Ecceto YL670AV	REC26904
280	8	Mallory	4499391	Excepto / Except / Ecceto YL670AV	REC26904
330	8	Mallory	4623115	Excepto / Except / Ecceto YL670AV	REC26904
370, 400, 440, 460TRS	8	Mallory	4179554	Excepto / Except / Ecceto YL670AV	REC26904
888	8	Mallory	3108723	Excepto / Except / Ecceto YL670AV	REC26904
888	8	Prestolite	3108723	Todos / All / Tutti	REC26903
888	8	Mallory	4762210 - 6218461	Excepto / Except / Ecceto YL670AV	REC26904
5.7	8	Ski Mallory	85B14627+	Excepto / Except / Ecceto YL670AV	REC26904

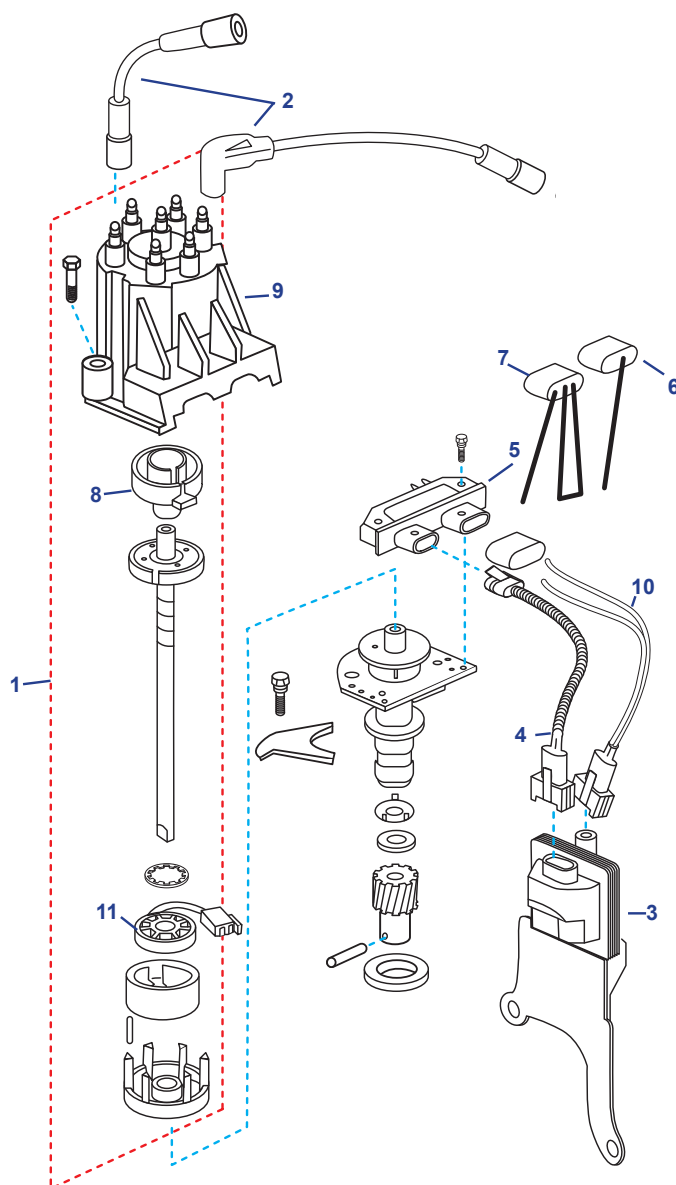
**DISTRIBUIDOR DELCO VOYAGER®  
DISTRIBUTOR DELCO VOYAGER®  
SPINTEROGENO DELCO VOYAGER®**

Nº	Ref.	R.O. OEM	Descripción	Description	Descrizione
1	REC817377	817377	DISTRIBUIDOR 4 CYL	DISTRIBUTOR 4 CYL	DISTRIBUTORE 4 CYL
1	REC807964A1	807964A1	DISTRIBUIDOR 6 CYL	DISTRIBUTOR 6 CYL	DISTRIBUTORE 6 CYL
1	REC805222A1	805222A1	DISTRIBUIDOR 8 CYL	DISTRIBUTOR 8 CYL	DISTRIBUTORE 8 CYL
2	REC15-405	84-816761Q13	KIT CABLE ARRANQUE: 3.0L	IGNITION WIRE SET: 3.0L	KIT CAVI INIEZIONE: 3.0L
2	REC15-601	84-816761Q16	KIT CABLE ARRANQUE: V6	IGNITION WIRE SET: V6	KIT CAVI INIEZIONE: V6
2	REC15-804	84-816761Q17	KIT CABLE ARRANQUE: V8	IGNITION WIRE SET: V8	KIT CAVI INIEZIONE: V8
3	REC3854002	898253T27	BOBINA ARRANQUE	COIL: IGNITION	BOBINA INIEZIONE
4	REC84-817376T01	84-817376T01	CABLE: DISTRIBUIDOR - BOBINA	WIRE LEAD: DIST- COIL	CAVO: DISTRIBUZIONE - BOBINA
5	REC3854003	811637001	MÓDULO DISTRIBUIDOR	MODULE: DISTRIBUTOR	MODULO DISTRIBUZIONE
6	REC294005		CABLE: INTERRUPTOR	WIRE: SHIFT INTERRUPTER	CAVO: INTERRUPTORE
7	REC91-888863	91-888863	HERRAMIENTA DISTRIBUIDOR	TOOL: TIMING	STRUMENTO DISTRIBUZIONE
8	REC3854311	850485	ROTOR V6	ROTOR V6	ROTORE V6
8	REC3854549	8M6001253	ROTOR V8	ROTOR: V8	ROTORE: V8
8	REC3854261	8M6001254	ROTOR 4 CYL	ROTOR 4 CUL	ROTORE 4 CYL
9	REC3854260	3854260	TAPA 4 CYL	CAP 4 CYL	COPERCHIO 4 CYL
9	REC3854311	3854311	TAPA 6 CYL	CAP 6 CYL	COPERCHIO 6 CYL
9	REC3854548	3854548	TAPA 8 CYL	CAP 8 CYL	COPERCHIO 8 CYL
10	REC500442		CABLE: BOBINA	WIRE LEAD: COIL HARNESS	CAVO BOBINA
11	REC3854001	811639T	MÓDULO IMPULSOS	MODULE	MODULO

**DISTRIBUIDOR MPI V6 & V8  
DISTRIBUTOR MPI V6 & V8  
SPINTEROGENO MPI V6 & V8**

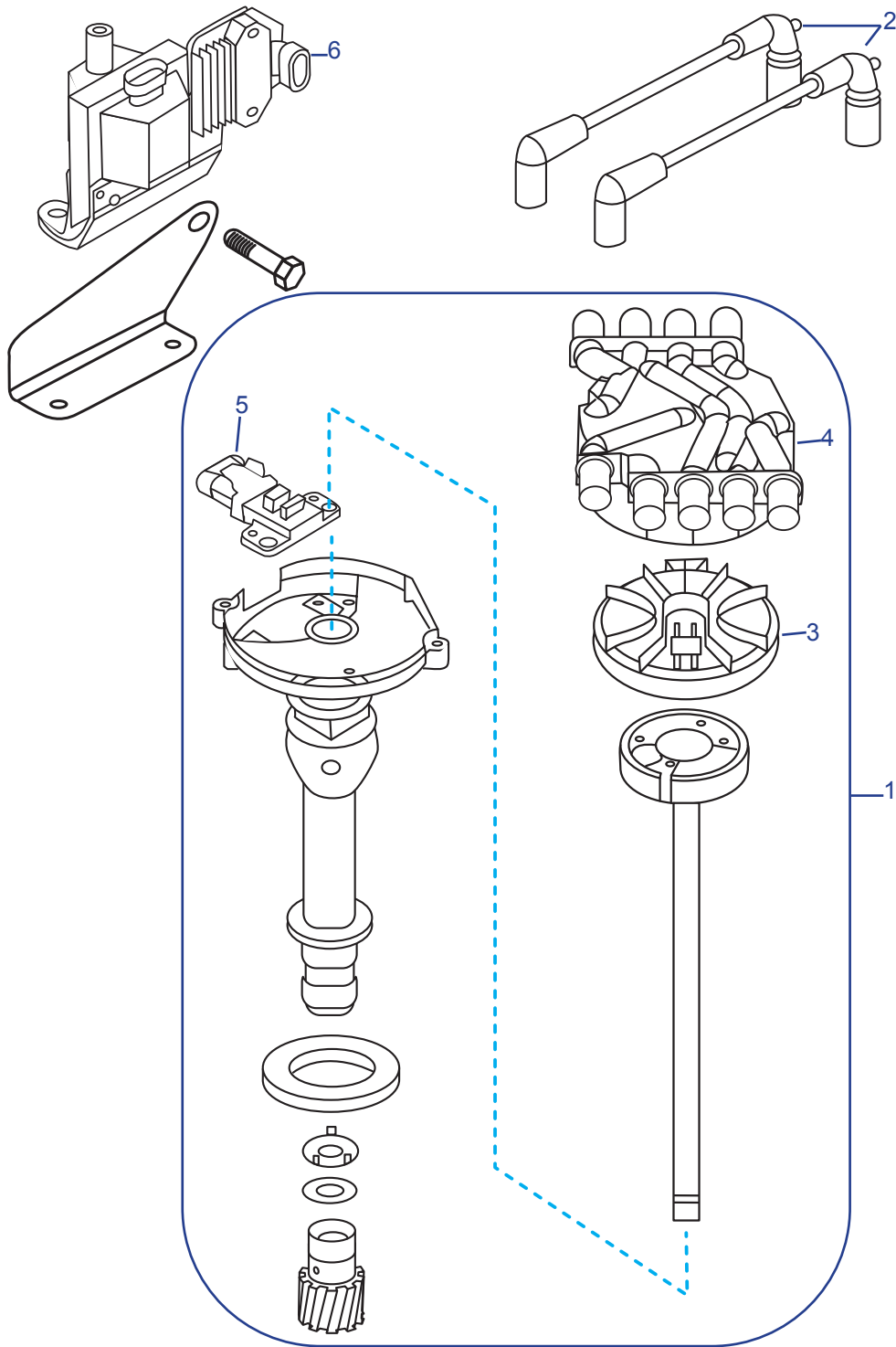

Nº	Ref.	R.O./ OEM	Descripción	Description	Descrizione
1	REC40005334	888751A03	DISTRIBUIDOR V6	DISTRIBUTOR V6	DISTRIBUTORE V6
1	REC2162232	879150A87	DISTRIBUIDOR V8	DISTRIBUTOR V8	DISTRIBUTORE V8
2	REC15-606	84-863656A2	KIT CABLES V6	WIRES KIT V6	KIT CAVI V6
2	REC15-815	84-816608A1	KIT CABLES V8 (5.0L, 5.7L)	WIRES KIT V8 (5.0L, 5.7L)	KIT CAVI V8 (5.0L, 5.7L)
2	REC15-813	84-863656A1	KIT CABLES V8 (6.2L)	WIRES KIT V8 (6.2L)	KIT CAVI V8 (6.2L)
3	REC898253013	8M6001222	ROTOR	ROTOR	ROTORE
4	REC898253T23	898253T23	TAPA V6	CAP V6	COPERCHIO V6
4	REC898253T22	898253T22	TAPA V8	CAP V8	COPERCHIO V8
5	REC3863130	898141	SENSOR POSICIÓN ÁRBOL DE LEVAS	POSITION SENDER CRANKSHAFT	SENSORE POSIZIONE ALBERO A CAMME
6	REC3861985	392-8M0054588	BOBINA ENCENDIDO	IGNITION COIL	BOBINA INIEZIONE

## DISTRIBUIDOR THUNDERBOLT IV & V DISTRIBUTOR ASSEMBLY IV & V SPINTEROGENO THUNDERBOLT IV E V

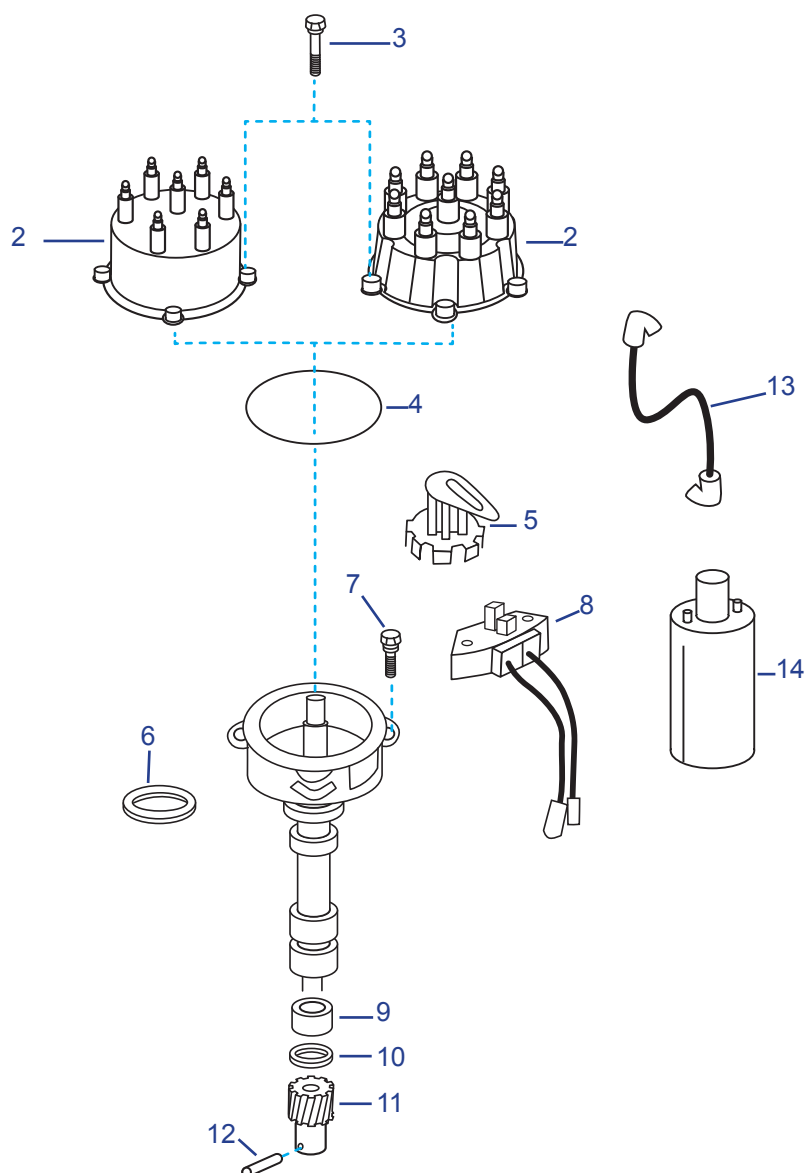

Nº	Ref.	R.O./ OEM	Descripción	Description	Descrizione
1	REC805185A3	805185A37	DISTRIBUIDOR V6 CON TERMINAL	DISTRIBUTOR ASSY. V6 W/BULLET	SPINTEROGENO V6 CON TERMINALI
1	REC805185A36	805185A36	DISTRIBUIDOR V8 CON TERMINAL	DISTRIBUTOR ASSY. V8 W/BULLET	SPINTEROGENO V8 CON TERMINALI
2	REC815407A2	815407Q02	TAPA DISTRIBUIDOR V6	DISTRIBUTOR CAP V6	CALOTTA V6
2	REC805759Q01	805759Q01	TAPA DISTRIBUIDOR V8	DISTRIBUTOR CAP V8	CALOTTA V6
3	REC10-90926	10-90926	TORNILLO	SCREW	VITE
4	REC27-805760	27-805760	JUNTA	GASKET	COPERCHIO
5	REC13524A6	13524Q06	ROTOR V6	ROTOR ASSEMBLY.	ROTORE V6
5	REC13524A1	13524T1	ROTOR V8	ROTOR ASSEMBLY	ROTORE V8
6	REC27-344861	27-34486-3	JUNTA	GASKET	GUARNIZIONE
7	REC10-66686	10-66686	TORNILLO 1"	SCREW 1"	VITE 1"
8	REC87-892150Q02	87-892150Q02	MÓDULO DISTRIBUIDOR	SENSOR ASSEMBLY	MODULO SPINTEROGENO
9	REC23-90915	23-90915	CASQUILLO	BUSHING	BOCCOLA
10	REC12-90931	12-90931	ARANDELA	WASHER	RONDELLA
11	REC43-818807	43-818807	PIÑÓN DELCO	DRIVE GEAR	PIGNONE DELCO
12	REC17-47617	17-47617	PASADOR	PIN	CHIAVISTELLO
13	REC15-601	84-816761Q16	KIT CABLES BUJÍAS V6	WIRES KIT V6	KIT CAVI V6
13	REC15-804	84-816761Q17	KIT CABLES BUJÍAS V8	WIRES KIT V8	KIT CAVI V8
14	REC300-00879	392-805570A2	BOBINA	COIL	BOBINA

**DISTRIBUIDOR ELECTRÓNICO  
ELECTRONIC DISTRIBUTOR  
SPINTEROGENO ELETTRICO**

Ref.	R.O. OEM
REC805185A3	805185A3

**MOTORES / ENGINES / MOTORI**  
V6. HEI Modernos / late / moderno



Ref.	R.O. OEM
REC805185A36	805185A36

**MOTORES / ENGINES / MOTORI**  
V8. HEI Modernos / late / moderno

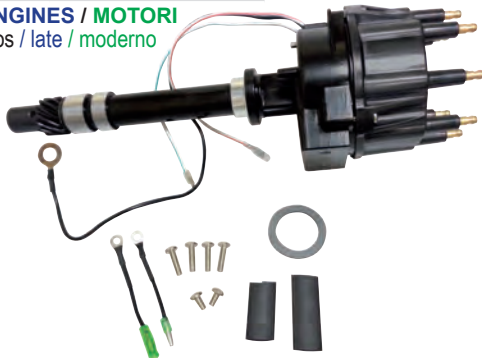

Ref.	R.O. OEM
REC817377	817377 817377T

**MOTORES / ENGINES / MOTORI**  
181 RX  
(LX - MPI)  
Delco est ignition



**NEW**

Ref.	R.O. OEM
REC807964A1	807964A1 907964A1

**MOTORES / ENGINES / MOTORI**  
V6  
(EFI - TBI)



**NEW**

Ref.	R.O. OEM
REC805222A1	805222A1

**MOTORES / ENGINES / MOTORI**  
V8  
(EFI - TBI - MPI)  
262-454 & 452  
excepto 384 / 409  
except 384 / 409  
eccetto 384 / 409

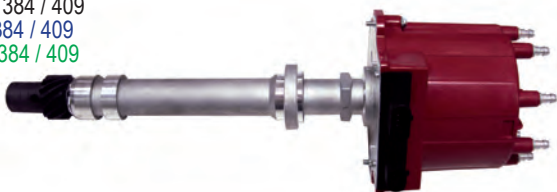

**NEW**

**DISTRIBUIDOR  
DISTRIBUTOR  
SPINTEROGENO**

Ref.	R.O. OEM
REC40005334	888751A03 88751A02 888751A1

**MOTORES / ENGINES / MOTORI**  
Vortec V6 4.3i MPI (2002+)  
(0M300000+)

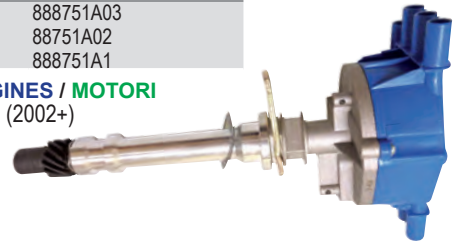

Ref.	R.O. OEM
REC21622232	884794A02 879150A87 884794A1

**MOTORES / ENGINES / MOTORI**  
Vortec V8 2001+  
5.0L, 5.7L, 6.2L MPI  
(0M300000+)

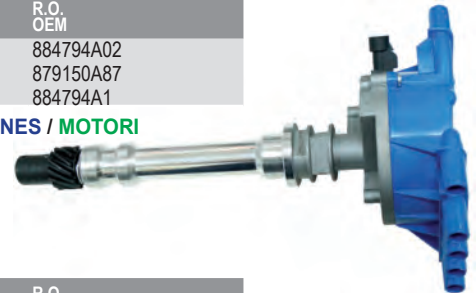

Ref.	R.O. OEM
REC195141	87581T 195141 87581 62424 58231 52352 33266

**MOTORES / ENGINES / MOTORI**  
GM 4 CIL. (120 & 140)  
MALLORY YL673AV

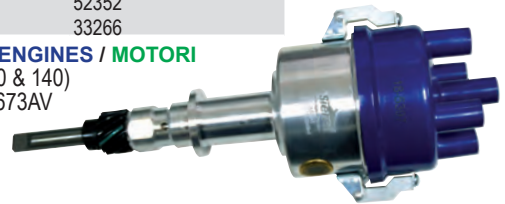

Ref.	R.O. OEM
REC17177A1	17177A1 91823A3 816148A1 74905A3 68521A4 68521A3 13447A1

**MOTORES / ENGINES / MOTORI**  
GM V8. (Small & large block)  
MALLORY YL 624 AV



Ref.	R.O. OEM
REC392-6316	392-6316

**MOTORES / ENGINES / MOTORI**  
FORD 302 CID V8  
MALLORY YL512CV



Ref.	R.O. OEM
REC392-6330	392-6330

**MOTORES / ENGINES / MOTORI**  
FORD 351 CID V8  
MALLORY YL554CV



## BOBINAS COILS BOBINE

### ENCENDIDO ELECTRÓNICO ELECTRONIC IGNITION ACCENSIONE ELETTRONICA

Ref.	R.O. OEM
REC300-00879	392-805570A2 392-7803A4

NO USA RESISTENCIA EXTERNA  
USE WITHOUT EXTERNAL RESISTOR  
NON UTILIZZA RESISTENZA ESTERNA

HEI  
Sistema de encendido Thunderbolt  
Thunderbolt ignition system  
Sistema di accensione Thunderbolt

Ref.	R.O. OEM
REC1463-9382	898253T24 392-806529A1 32193A2 38547

USA RESISTENCIA EXTERNA  
USE WITH EXTERNAL RESISTOR  
UTILIZZA RESISTENZA ESTERNA

DELCO 1115202



Ref.	R.O. OEM
REC3859078	392-889925

MOTORES / ENGINES / MOTORI  
8.1L & 496 Mag (OM315053 +)



Ref.	R.O. OEM
REC806673T1	806673T1 806673T

MOTORES / ENGINES / MOTORI  
V8 (5.0 & 5.7L)



Ref.	R.O. OEM
REC3861267	392-881732

MOTORES / ENGINES / MOTORI  
Motores 496 Magnum  
8.1 Inboard



### BOBINA ENCENDIDO IGNITION COIL BOBINA ELETTRONICA

Ref.	R.O. OEM
REC3854002	898253T27 817378 817378T

MOTORES / ENGINES / MOTORI  
4 CIL. (V6 & V8)



Ref.	R.O. OEM
REC3861985	392-863704T 8M0054588

MOTORES / ENGINES / MOTORI  
2001+  
4.3, 5.0, 5.7 & 6.2L EMC  
OM300000+

NEW



## MODULOS IGNICIÓN IGNITION MODULES MODULI AVVIAMENTO

Ref.	R.O. OEM
RM805361T3	805361T3

MOTORES / ENGINES / MOTORI  
5.0/5.7 L (1987-95)



Ref.	R.O. OEM
RM15247A1	15247A1 15247T02

MOTORES / ENGINES / MOTORI  
4.3 L (1987-93)





Ref.	R.O. OEM
RM15248A1	15248A1 15248T02

**MOTORES / ENGINES / MOTORI**  
7.4/8.2 L (1981-96)



Ref.	R.O. OEM
RM805361T2	805361T2

**MOTORES / ENGINES / MOTORI**  
7.4 L (1992-96)



Ref.	R.O. OEM
RM805361T6	805361T6

**MOTORES / ENGINES / MOTORI**  
5.0/5.7/7.4 L (1987-96)



Ref.	R.O. OEM
RM821125A1	821125A1 821125T02

**MOTORES / ENGINES / MOTORI**  
5.0/5.7 L (1987-96)



Ref.	R.O. OEM
REC3854001	811639T

**MOTORES / ENG**  
V4, V6, V8  
Delco Voyager

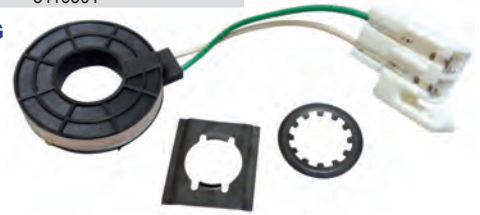

Ref.	R.O. OEM
RM15899A1	15899A1 15899T02

**MOTORES / ENGINES / MOTORI**  
5.0/5.7 L (1987-95)



Ref.	R.O. OEM
REC3854003	811637T 811637001 81637002 811637 850487 804412 802464

**MOTORES / ENGINES / MOTORI**  
4L, V6 & V8 Delco Voyager



Ref.	R.O. OEM
REC3858984	GM10482803

**MOTORES / ENGINES / MOTORI**  
4.3, 5.0, 5.7 & 6.2L MPI ECM555  
(2001+)  
OM300000+  
Para bobina / for coil / per bobina:  
REC3861985



## BUJÍAS SPARK CANDELE



Modelo Modelo	CYL/ CID	SERIE SERIAL SERIE	Ref. CHAMPION
110	4, 153 CID		CHARN5C
110	4, 153 CID		CHARV15YC4
140	4, 181 CID	-3826282	CHARN5C
140	4, 181 CID	3826283	CHARV15YC4
3.0	4, 181 CID	-0F353100	CHARV15YC4
3.0	4, 181 CID	0L010042+	CHARS12YC
3.0 LX	4, 181 CID		CHARS12YC
470, 165, 170, 485, 488, 180, 190,	4, 224 CID		CHARS12YC
3.7L, 3.7LX,	4, 224 CID		CHARS12YC
140, 150, 160,	4, 224 CID		CHARS12YC
165	6, 194, 230 & 292 CID	- 2771483	CHARN5C
165	6, 194, 230 & 292 CID	2771484	CHARV15YC4
200	6, 194, 230 & 292 CID		CHARN5C
185	V6, 229 CID		CHARV15YC4
175, 185, 205	V6, 262 CID		CHARV15YC4
262 MAG EFI GEN+	V6, 262 CID	0F80800-0L000000	CHARS12YC
4.3L MPI	V6, 262 CID		CHARV15YC4
4.3L	V6, 262 CID	-0F802999	CHARV15YC4
4.3LX	V6, 262 CID	0F802999+	CHARV15YC4
4.3 GEN+	V6, 262 CID	0L010065+	CHARS12YC
4.3LL EFI GEN+	V6, 262 CID	0L012009+	CHARS12YC

Modelo Modelo	CYL/ CID	SERIE SERIAL SERIE	Ref. CHAMPION
4.3LH GEN+	V6, 262 CID	0L010044+	CHARS12YC
4.3LX GEN+	V6, 262 CID	0F803000-0L000000	CHARS12YC
4.3LXH GEN+	V6, 262 CID	0F803000-0L000000	CHARS12YC
888 Culata / Head / Testata 14mm FORD V8	CHARV15YC4	4169597	CHARV15YC4
233 Culata / Head / Testata 14mm	FORD V8		CHARV15YC4
255 Culata / Head / Testata 14mm FORD V8	CHARV15YC4	4175499	CHARV15YC4
190	V8 283, 327, 305, 350 CID		CHARJ12YC
898, 200	V8 283, 327, 305, 350 CID		CHARV9IMC
225	V8 283, 327, 305, 350 CID	2278647	CHARJ12YC
228, 230	V8 283, 327, 305, 350 CID		CHARV9IMC
250	V8 283, 327, 305, 350 CID	4768000	CHARV15YC4
255	V8 283, 327, 305, 350 CID		CHARV15YC4

Modelo Model Modello	CYL/CID	SERIE SERIAL SERIE	Ref. CHAMPION
260	V8 283, 327, 305, 350 CID		CHARV9IMC
280, 300 Tempest, 320 EFI	V8 283, 327, 305, 350 CID		CHARV15YC4
350 Mag (Carb)	V8 283, 327, 305, 350 CID		CHARV9IMC
350 Mag EFI/MP	V8 283, 327, 305, 350 CID	-0F602199	CHARV9IMC
350 Mag EFI GEN+ V8	CHARS12YC	0F800500+	CHARS12YC
350 Mag MPI GEN+ V8	CHARS12YC	0F602000+	CHARS12YC
350 Mag MPI GEN+ V8	CHARS12PYP	0L604000+	CHARS12PYP
377 Scorpion	V8 283, 327, 305, 350 CID	0L416146+	CHARS12YC
5.0L MPI	V8 283, 327, 305, 350 CID		CHARS12YC
5.0L	V8 283, 327, 305, 350 CID	- 0L000000	CHARV9IMC
5.0L GEN+	V8 283, 327, 305, 350 CID	0L015751	CHARS12YC
5.0L EFI GEN+	V8 283, 327, 305, 350 CID	0L012052	CHARS12YC
5.0LX	V8 283, 327, 305, 350 CID		CHARV9IMC
5.7L	V8 283, 327, 305, 350 CID	-0L000000	CHARV9IMC
5.7L EFI	V8 283, 327, 305, 350 CID	-0L000000	CHARV9IMC
5.7L GEN+	V8 283, 327, 305, 350 CID	0L010037+	CHARS12YC
5.7L EFI GEN+	V8 283, 327, 305, 350 CID	0L010035+	CHARS12YC
5.7LX, 5.7LX EFI	V8 283, 327, 305, 350 CID		CHARV9IMC
5.7LX EFI GEN+	V8 283, 327, 305, 350 CID		CHARS12YC
325	V8 427, 454 & 482 CID	3043030	CHAV63C
330, 330 (B-W), 370, 400, 400 Cyclone	V8 427, 454 & 482 CID		CHARV15YC4
420, HP425, 440 Cyclone, HP450	V8 427, 454 & 482 CID		CHARV15YC4
454 Mag Alpha, Bravo, EFI/MP/MPI	V8 427, 454 & 482 CID		CHARV15YC4
460 Cyclone, 475 Turbo, HP525 SC	V8 427, 454 & 482 CID		CHAV63C
7.4L Alpha, 7.4L Bravo	V8 427, 454 & 482 CID		CHARV15YC4
7.4L TR	V8 427, 454 & 482 CID	OB771113-OC407646	CHARV15YC4
7.4L MPI (L29)	V8 427, 454 & 482 CID	0L010003+	CHARS12YC
7.4LX EFI, 7.4LX MPI	V8 427, 454 & 482 CID		CHARV15YC4
HP465, HP500 (502 CID), HP500 EFI	V8 502, 540 & 572 CID		CHARV15YC4
HP500 Bulldog 540, HP525 SC 454	V8 502, 540 & 572 CID		CHAV63C
HP575, HP600SC Bobtail (502 CID)	V8 502, 540 & 572 CID		CHAV63C
HP800SC (572 CID)	V8 502, 540 & 572 CID		CHAV63C
502 MAG (CARB.), EFI/ MA/MPI	V8 502, 540 & 572 CID		CHARV15YC4
600SC, 800SC	V8 502, 540 & 572 CID		CHAV63C

**BUJÍAS  
SPARK  
CANDELE**



Modelo Model Modello	CYL	SERIE SERIAL SERIE	Ref. STANDARD	Ref. IRIDIUM
110	4		NGKBR6ES	
120	4	-3825578	NGKBR6ES	
140	4	-3825578	NGKBR6ES	
2.5L 153, CID	4		NGKBR6EF	
3.0L 181 CID	4	OL010042+	NGKBPR6EFS	NGKTR6IX
3.0L 181 CID	4	-0F3353100	NGKBR6ES	
3.0LX	4		NGKBPR6EFS	NGKTR6IX
165 224 CID, 170 224 CID	4		NGKBR6FS	
180 224CID, 190 224 CID	4		NGKBR6FS	
3.7L 224 CID, 3.7LX 224 CID	4		NGKBR6FS	

Modelo Model Modello	CYL	SERIE SERIAL SERIE	Ref. STANDARD	Ref. IRIDIUM
470 224CID, 485 224CID, 488 224CID	4		NGKBR6FS	
140, 150, 160	6		NGKBR6ES	
165	6	-2771483	NGKBR6ES	
200, 175, 185, 205, 185 229 CID	6		NGKBR6FS	
262 MAG EFI GEN+	6	OF803800-OL00000	NGKBPR6EFS	NGKTR6IX
4.3L	6	-0F802999	NGKBR6ES	
4.3L EFI GEN+	6	OL012009+	NGKBPR6EFS	NGKTR6IX
4.3L GEN+	6	OL010065+	NGKBPR6EFS	NGKTR6IX
4.3LH EFI GEN+	6	OL010044+	NGKBPR6EFS	NGKTR6IX
4.3L mpi gen +	6	OM322781+	NGKTR55	NGKTR55IX
4.3LX	6	-0F802999	NGKBR6ES	
4.3LX GEN+	6	OF803000 - OL00000	NGKBPR6EFS	NGKTR6IX
4.3LXH GEN+	6	OF803000 - OL00000	NGKBPR6EFS	NGKTR6IX
4.5 MPI	6		NGKBPR5EFS-13	
250	8	4768000 +	NGKBR6FS	NGKBR6FIX
255 - 260	8		NGKBR6FS	NGKBR6FIX
280, 300 Tempest, 320 EFI, 350 MAG	8		NGKBR6FS	NGKBR6FIX
5.0L	8	-OL000000	NGKTR5	NGKYR5IX
5.0L EFI GEN+	8	OL015751+	NGKBPR6EFS	NGKTR6IX
5.0L MPI GEN+	8	OM320415+	NGKTR55	NGKTR55IX
5.0L MPI Alpha/Bravo	8			NGKITR4A15
5.0LX	8		NGKYR5	NGKYR5IX
5.0L MPI 2002+	8		NGKBPR6EFS	NGKTR6IX
5.7L, 5.7LEFI	8	-OL000000	NGKBR6FS	NGKBR6FIX
5.7L EFI GEN+	8	OL010035+	NGKBPR6EFS	NGKTR6IX
5.7L GEN+	8	OL010037+	NGKBPR6EFS	NGKTR6IX
5.7LX, 5.7LX EFI	8		NGKBR6FS	NGKBR6FIX
5.7LX EFI GEN+	8		NGKBPR6EFS	NGKTR6IX
5.7 MPI Horizon MIE	8			NGKITR4A15
5.7 MPI MIE	8			NGKITR4A15
5.7 Black Scorpion	8	OM391852 +	NGKTR55	NGKTR55IX
5.7 Black Scorpion	8	OM391778 +	NGKTR55	NGKTR55IX
350 MAG EFI GEN+	8	OF800500 +	NGKBPR6EFS	NGKTR6IX
350 MAG EFI/MP	8	OF602199 +	NGKBR6FS	NGKBR6FIX
350 MAG MPI GEN+	8	OF602000 - OM320489	NGKBR6FS	NGKTR6IX
350 MAG MPI GEN+	8	OM320590+	NGKTR55	NGKTR55IX
350 MAG MPI GEN+ Horizon	8	OL304700- OM309999	NGKTR5	NGKTR55IX
350 MAG MPI Alpha/ Bravo	8			NGKITR4A15
350 MAG MPI Horizon Alpha/Bravo	8			NGKITR4A15
377Magnum MPI Bravo	8			NGKITR4A15
898, 200	8		NGKYR5	NGKYR5IX
6.2 MPI MIE	8			NGKITR4A15
6.2 MPI Horizon MIE	8			NGKITR4A15
MX6.2 MPI	8	-OM320613	NGKBPR6EFS	NGKTR6IX
MX6.2L MPI	8	OM320614+	NGKTR55	NGKTR55IX
MX6.2 MPI Horizon	8	OM320614+	NGKTR55	NGKTR55IX
Scorpión	8	OL416146+	NGKBPR6EFS	NGKTR6IX
233	8		NGKBPR6EFS	NGKTR6IX
255	8	-4175498	NGKBR6FS	NGKBR6FIX
255	8	4175499+	NGKBPR6EFS	NGKTR6IX
888	8	4169597+	NGKBPR6EFS	NGKTR6IX
330	8		NGKBR6ES	
390	8		NGKBR6ES	
420, 440 Ciclone, 454MAG ALPHA	8		NGKBR6FS	NGKBR6FIX
454 Magnum Bravo, 454 MAF EFI-MPI	8		NGKBR6FS	NGKBR6FIX
502 MAG, 502 MAG EFI-MP, MPI	8		NGKBR6FS	NGKBR6FIX
7.4L ALPHA, 7.4L Bravo	8		NGKBR6FS	NGKBR6FIX
7.4L MPI (L29)	8		NGKBPR6EFS	NGKBR6FIX
7.4LX EFI Bravo, MPI Bravo	8		NGKBR6FS	NGKBR6FIX
7.4TR	8	OB771113 - OC407646	NGKBR6FS	NGKBR6FIX
HP425, HP450, HP465, HP500, 502CID	8		NGKBR6FS	NGKBR6FIX
8.1L, 8.1 SHO, 8.1 S Horizon (2000-06)	8		NGKTR55	NGKTR55IX
8.1 SHO, 8.1 S Horizon (2007 +)	8			NGKIZFR7M

## JUEGOS DE CABLE PARA BUJÍAS DE ALTO RENDIMIENTO HD SPARK PLUG WIRE SET KIT CAVI CANDELE ALTE PRESTAZIONI

- Núcleo del cable de Kevlar de 8 mm antimagnético
- Funda de silicona amarilla
- Terminales bujías con muelle de acero inox
- Terminal del Distribuidor de Cobre
- Terminales Bobina
- Silicona resistente a altas temperaturas
- Garantía de 5 años

- Antimagnetic Kevlar core
- Yellow silicone boot & jacket
- SS snaplock
- Brass distributor terminal
- Coil terminals
- High resistant silicone
- 5 year warranty

- Nucleo del cavi in Kevlar da 8 mm antimagnetico
- Fodera in silicone gialla
- Terminali candele con mole di acciaio inox.
- Terminale lato spinteorgeno in rame
- Terminali Bobina
- Silicone resistente alle alte temperature
- Garanzia 5 anni

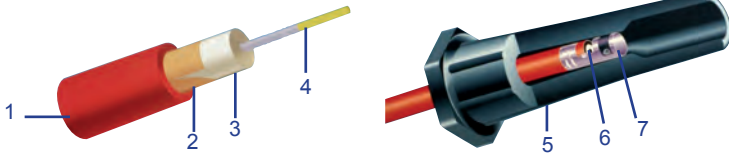

Nº			
1	Camisa de silicona de 8 mm	8 mm silicone jacket	Guaina in silicone da 8 mm
2	Látex resistente altas temperaturas	Heat resistant latex	Latex resistente alle alte temperature
3	Acero inox	Stainless Steel	Acciaio inox
4	Núcleo de Kevlar	Kevlar core	Nucleo in Kvlar
5	Capuchón de silicona	Silicone jacket	Cappuccio in silicone
6	Trenzado fibra	Fiberglass braiding	Fibra di vetro
7	Terminal de acero inox	Stainless Steel terminal	Terminale in acciaio inox

Ref	R.O. OEM	MODELO MODELLO	ARRANQUE IGNITION AVVIAMENTO		CYL
			CONVENCIONAL CONVENZIONALE	ELECTRÓNICO ELETTRONICO	
REC15-401	84-813720A5	110/120/2.5L 140/3.0L	✓		4
REC15-405	84-813720A13	120/2.5L 140/3.0L 3.0LX		✓	4
MAG15-602	84-813720A8 84-816761Q8	140-185(EN LINEA 6)	✓		6
REC15-402	84-813720A5	165-180 LX/470- 485 190 (3.7L)	✓		4
REC15-601	84-813720A11	175/185 (228, 262) 4.3L (GENI)		✓	6
REC15-604	84-813720A7 84-816761Q7	185 (229)	✓		6
REC15-801	84-813720A8 84-813720A10	180 (GM)	✓		8
REC15-804	84-813720A4 84-818781A4 84-8167681A17 84-813720A3	200/5.0L (GM)		✓	8
REC15-606		4.3L 2002 + MPI		✓	6
REC15-801	84-813720A8 84-813720A10	215-225S 223FORD 22S-228GM	✓		8
REC15-804	84-813720A4 84-816761A4 84-816878A17 84-813720A3	228-230/5.0L LX (GM)		✓	8
REC15-801	84-813720A8 84-813720A10	255 (FORD) 250-225-225-280(GM)	✓		8
REC15-815	84-816608A1	5.0L GENE+ 2002+ MPI		✓	8
REC15-804	84-813720A2 84-816781A4 84-816761A17 84-813720A3	350 (5.7L) MAG., SKI		✓	8
REC15-815	84-816608A1	5.7L GENE+ 2002+ MPI		✓	8
REC15-801	84-813720A8 84-813720A10	270/280/350 (GM)	✓		8
REC15-804	84-816761A2 84-816781A15 84-816761A6 84-816761A15	300MR/TRS (GM)		✓	8
REC15-804	84-813720A4 84-816781A4 84-816761A17 84-813720A3	260/320/325 /330/340 (GM)		✓	8
REC15-801	84-813720A8 84-813720A10	370/380/400/ 440/460 TRS	✓		8
REC15-804	84-816761A2 84-816781A15 84-816761A8 84-816761A15	420/425/486 /525/575		✓	8

Ref	R.O. OEM	MODELO MODELLO	ARRANQUE IGNITION AVVIAMENTO		CYL
			CONVENCIONAL CONVENZIONALE	ELECTRÓNICO ELETTRONICO	
REC15-804	84-816761A2 84-816781A15 84-816761A8 84-816761A15	454/500/502 MAG BRAVO		✓	8
REC15-801	84-813720A8 84-813720A10	888 (FORD) 898,198 (GM)	✓		8
REC15-804	84-816761A2 84-816781A15 84-816761A8 84-816761A15	888 (GM) 5.7 BRAVO		✓	8
REC15-801	84-813720A9 84-813720A10	5.7 SKI	✓		8
REC15-804	84-816761A2 84-816781A15 84-816761A8 84-816761A15	7.4L BRAVO		✓	8
REC15-804	84-816761A2 84-816781A15 84-816761A8 84-816761A15	7.4L 8.2L CON HURTH		✓	8
REC15-804	84-816761A2 84-816781A15 84-816761A6 84-816761A15	300 MR/TRS (GM)		✓	8
REC15-804	84-816761A2 84-816781A15 84-816761A6 84-816761A15	330-340 (GM)		✓	8
REC15-804	84-816761A2 84-816781A15 84-816761A6 84-816761A15	454 MAG BRAVO 420/425/465 /525/575		✓	8
REC15-804	84-816761A2 84-816781A15 84-816761A6 84-816761A15	898 (GM) 5.7 BRAVO		✓	8
REC15-804	84-816761A2 84-816781A15 84-816761A6 84-816761A15	500/502 BRAVO		✓	8
MAG15-803	84-816761A2 84-816781A15 84-816761A6 84-816761A15	500/502 BRAVO		✓	8
REC15-804	84-816761A2 84-816781A15 84-816761A6 84-816761A15	7.4L BRAVO 7.4L-8.2L CON HURTH		✓	8
REC15-804	84-816761A2 84-816781A15 84-816761A6 84-816761A15	7.4L BRAVO 7.4L-8.2L CON HURTH		✓	8
REC15-813	84-863656A1	6.2L MPI MIE		✓	8
MAG15-809		454 MAGNUM		✓	
REC15-808		8.1L 496		✓	

## GUIA CORREAS MOTOR V-BELTS GUIDE GUIDA CINGHIA MOTORE

Ref.	R.O. OEM
REC57-13457Q	57-13457Q
REC966931	57-13458Q
REC3852106	57-32850 57-69143Q
REC57-34359	57-34359 57-37619T, Q
REC57-36356	57-36356
REC3858462	57-45856 57-49213A1 57-93658Q
REC829207	57-48120Q1
REC57-48122Q	57-48122Q

Ref.	R.O. OEM
REC57-49043A1	57-49043A1 57-64032Q1
REC57-64416	57-49211 57-64416
REC57-52692	57-52692
REC57-65607Q	57-65607T
REC966903	57-74271Q
REC966900	57-77274
REC57-78200Q1	57-78200Q1
REC57-816295Q	57-816295Q
REC57-91035Q1	57-91035Q1



Modelo Model Modello	Año Year Anno	SERIE SERIAL SERIE	ALTERNADOR BOMBA AGUA WATER PUMP ALTERNATOR ALTERNATORE POMPA ACQUA	DIRECCIÓN POWER STEERING IDROGUIDA	POMPA AGUA SALADA SEA WATER PUMP POMPA ACQUA SALATA
CMD 1.7MS 120 I/L4		8810800+		RM57-862054Q	
CMD 1.7MI 120 L/L4		88109041+		RM57-862054Q	
110	63-66	1537370 - 2044033	REC57-49043A1		
120	64-73	1666601-3770649	REC57-49043A1		
120	74-82	3770650-6229717	REC57-49043A1	REC57-65607Q (37")	
120	74-82	3770650-6229717	REC57-49043A1	REC3852106 (40")	
120(2.5L)	82-89	6229718 - C853255	REC57-49043A1		
120(2.5L)	82-89	6229718 - C853255 W/P/S	REC3852106	REC57-65607Q	
140	68-73	2508261-3770649	REC57-49043A1		
140	74-82	3770650-6229717	REC57-49043A1	REC57-65607Q (37")	
140	74-82	3770650-6229717	REC57-49043A1	REC3852106 (40")	
140/3.0L/3.0LX	1982	6229718 +	REC57-49043A1		
140/3.0L/3.0LX	1982	6229718+ W/P/S	REC3852106	REC57-65607Q	
150	64-66	1666495-2048646	REC57-49043A1		
160	67-69	2048022-2770031	REC57-49043A1		
165	70-73	2770032 - 3774864	REC57-49043A1		
165	74-81	3774865 - 5813433	REC57-49043A1	REC57-65607Q (37")	
165	74-81	3774865 - 5813433	REC57-49043A1	REC3852106 (40")	
165/170/180/190/3.7L	85-89	6916779 - C762299		REC57-49043A1	
470 (170HP)	76-82	4208730 - 6218036			
470 (170HP)	83-84	6218037 - 6916778		REC57-49043A1	
488	83-84	6170297 - 6916778		REC57-49043A1	
175	1987	OB527955-OB773242		REC57-816295Q	
175/185/4.3L	85-92	A331455 - D714106	REC3858462	REC57-34359	REC966903
3.0L GM 181 I/L4		OW302000+		RM57-862054Q	
3.0 MPI EC		1A072812+		RM57-862054Q	
3.0 TKS Pus		1G404114+		RM57-862054Q	
4.3L	92-96	D714107 - F802999	REC829207		REC57-13457Q
4.3L (2bbl)	88-92	OB773243-OD714106		REC57-816295Q	
4.3L (GenII) (2 bbl)	92-96	OD714107-OF802999		REC57-816295Q	
4.3LX (4bbl)	88-92	OB775130-OD714369		REC57-816295Q	
4.3LX (Gen II)	92-96	OD714370-OF802999		REC57-816295Q	
888	71-77	3108723 - 4887829	REC3858462		
888	71-77	3108723 - 4887829	REC3858462	REC57-13457Q (30")	REC3858462
898 W/O HIGH MT P/S	77-84	4762210 - 6218461	REC829207	REC966900	REC966903
898 W/ HIGH MT P/S	77-84	4762210 - 6218461	REC3858462	REC57-91035Q1	REC966903
898/200/5.0L	85-95	6218462 - F600999	REC3858462	REC57-91035Q1	REC966903
898/200/5.0L	85-95	6218462 - F600999	REC829207	REC57-34359	REC57-13457Q
200	1969	2453769 - 2712072	REC57-49043A1		
205	85-91	A331455 - D714369	REC3858462	REC57-34359	REC966903
215	70-72	2781153 - 3563181	REC3858462		
215 MIE	70-72	2781153 - 3563181	REC3858462		
225	73-74	3385721 - 4166999	REC3858462	REC57-34359	REC966903
225 MIE	73-74	3385721 - 4166999	REC3858462		
225 MCM/MIE	67-69	2278647 - 2694014	REC829207		
228 W/O HIGH MT P/S	77-82	4765100-6218461	REC829207	REC966900	REC966903
228 W/ HIGH MT P/S	77-82	4765100-6218461	REC3858462	REC57-91035Q1	REC966903
228/230/5.0L	83-95	6218462 - F600999	REC3858462	REC57-91035Q1	REC966903
228/230/5.0L	83-95	6218462 - F600999	REC829207	REC57-34359	REC57-13457Q
228 MIE	1977	4765100 - 4929030	REC829207		REC966900



Modelo Model Modello	Año Year Anno	SERIE SERIAL SERIE	ALTERNADOR BOMBA AGUA WATER PUMP ALTERNATOR ALTERNATORE POMPA ACQUA	DIRECCIÓN POWER STEERING IDROGUIDA	POMPA AGUA SALADA SEA WATER PUMP POMPA ACQUA SALATA
228/230/5.0L MIE	78-87	4929030 - B788151	REC3858462	REC57-91035Q1	REC966903
228/230/5.0L MIE	78-87	4929030 - B788151	REC829207	REC57-34359	REC57-13457Q
233	75-77	4173000 - 4902304	REC3858462		
233	75-77	4173000 - 4902304	REC3858462	REC57-13457Q	REC966903
233 MIE	75-76	4173000 - 4775784	REC3858462		
250	68-69	2314301 - 2639854	REC829207		
250	1977	4768000 - 4908849	REC3858462	REC966903	REC966903
255 MCM/MIE	73-74	3258728 - 4175499	REC3858462		
255	75-76	4175500 - 4498700	REC829207		
255	1976	4498701-4499060	REC829207		
255	1976	4499061-4767999	REC829207		
255 MIE	75-77	4175500 - 4498700	REC829207		
255 MIE	77-78	4498701 - 4924564	REC829207		REC966903
255/260/5.7L MIE & Ski	78-86	4924565 - B522505	REC3858462		REC966903
260/5.7L MIE & Ski	87-93	B522506 - F024999	REC3858462		REC966903
260/5.7L MIE & Ski	87-93	B522506 - F024999	REC829207		REC57-13457Q
5.7L MIE & Ski	94-96	F025000 - K040306	REC829207		REC57-13457Q
260 W/WM P/S	78-82	4908850 - 6218461	REC3858462	REC57-91035Q1	REC966903
260 W/LM P/S	1978-82	4908850 - 6218461	REC829207		REC966903
260/5.7L	1983-95	6218462 - F600999	REC3858462	REC57-91035Q1	REC966903
260/5.7L	1983-95	6218462 - F600999	REC829207	REC57-34359	REC57-13457Q
5.7L/5.7LX	1996	F601000 - K001526	REC829207	REC57-816295Q	REC57-13457Q
350 MAG	1986-95	A635178 - F600999	REC3858462	REC57-34359	REC966903
350 MAG	1986-95	A635178 - F600999	REC829207		REC57-13457Q
350 MAG	1996	F601000 - K001500	REC829207		REC57-13457Q
350 MAG Ski	1991-96	D505450 - K040005	REC829207		REC57-13457Q
Black Scorpion Ski	1996	F800000 - K040000	REC829207		REC57-13457Q
270 MCM/MIE	1969-72	2851074 - 3385720	REC829207		
280	1975	4176250 - 4176468	REC829207		
280	1975-76	4176469 - 4499390	REC829207		
280	1976	4499391 - 4499780	REC829207		
280	1976	4499781 - 4770199	REC829207		
5.7L	1988-96	OB525982-OF600999		REC57-816295Q	
5.7LEFI (2bbl)	1996	OF752400-OK001505		REC57-816295Q	
5.7L Alpha EFI (TBI)	1995	OF355305-OF752389		REC57-816295Q	
5.7L Bravo EFI (TBI)	1995	OF225560-OF752399		REC57-816295Q	
5.7LX Bravo EFI (Gen+)	1996	OF800300-OK001508		REC57-816295Q	
5.7LX EFI (4bbl TBI)	1996	OF752400-OK001505		REC57-816295Q	
320(EFI)	1987-89	A543604 - C622418	REC3858462	REC57-34359	
325 MCM/MIE	1968-74	2278747 - 3780449	REC57-48122Q		
330	1977-81	4623115-6083144	REC57-78200Q1		REC966903
330	1982-87	6083144 - B816540	REC57-78200Q1	REC57-96834Q (50")	REC966903
330	1982-87	6083144 - B816540	REC57-78200Q1	REC966931 (55")	REC57-13457Q
340 (7.4L)	1981-92	5889914 - D715493	REC57-78200Q1		REC966903
340 (7.4L)	1981-92	5889914 - D715493	REC57-78200Q1		REC57-13457Q
350 MIE	1974-75	3780450-4501640	REC57-48122Q		
350 MIE	1976	4501641 - 4623109	REC57-48122Q		REC966903
350 Mag Alpha	1987-95	OB525982-OF600999		REC57-816295Q	
350Mag Alpha (4bbl)	1996	OF601000-OK001526		REC57-816295Q	
350Mag Alpha EFI (Gen+)	1996	OF800300-OK001508		REC57-816295Q	
350Mag Bravo MPI	1995	OF415189-OF601999		REC57-816295Q	
350Mag Bravo MPI (Gen+)	1996	OF602000-OK001500		REC57-816295Q	
7.4L BRAVO	1988-91	B771113 - D603117	REC57-78200Q1	REC966931	REC57-13457Q
7.4L BRAVO	1988-91	B771113 - D603117	REC57-48122Q		REC57-13457Q
7.4L/LX BRAVO	1992-97	D603118 - K999999	REC57-48122Q		REC3852106
7.4LX Bravo (TBI)	1996-97	F820000 - K999999	REC57-48122Q		REC57-13457Q
7.4LX Bravo (MPI)	1996-97	F602010 - K147349	REC57-48122Q		REC3852106
7.4LX Bravo (MPI)	1997	K147350 - K999999	REC57-48122Q		REC57-13457Q
7.4L MIE	1989-92	C391564 - D715493	REC57-78200Q1		REC57-13457Q
7.4L MIE	1989-92	C391564 - D715493	REC57-48122Q		REC57-13457Q
7.4L MIE	1992-97	C391564 - K999999	REC57-48122Q		REC3852106
454 MAG Alpha	1986-88	A631894 +	REC57-78200Q1	REC57-96834Q (50")	
454 MAG Alpha	1986-88	A631894+	REC57-78200Q1	REC966931 (55")	
454 MAG	1988-92	B721206 - D805068	REC57-78200Q1	REC966931	REC57-13457Q
454 MAG	1988-92	B721206 - D805068	REC57-48122Q		REC57-13457Q
454 MAG	1992-97	D805069 - K999999	REC57-48122Q		REC3852106
454 MAG (MPI)	1994-97	F115700 - K147349	REC57-48122Q		REC3852106
454 MAG (MPI)	1997	K147350 - K999999	REC57-48122Q		REC57-13457Q

Modelo Model Modello	Año Year Anno	SERIE SERIAL SERIE	ALTERNADOR BOMBA AGUA WATER PUMP ALTERNATOR ALTERNATORE POMPA ACQUA	DIRECCIÓN POWER STEERING IDROGUIDA	POMPA AGUA SALADA SEA WATER PUMP POMPA ACQUA SALATA
454 MAG Ski	1995-97	F215800 - K999999	REC57-48122Q		REC3852106
370(TRS)	1978-85	4179554 - 6721527	REC57-48122Q		
370(TRS)	1985-87	6721528 - B714586	REC57-48122Q	REC57-96834Q	
390 MCM/MIE	1969-70	2781129 - 3042731	REC57-48122Q		
400 (TRS)	1980-86	4179554 - B457644	REC57-48122Q		
420/425	1987-92	A398941 - D725499	REC57-48122Q	REC57-96834Q	
420/425	1992	D725500 - D937011	REC57-48122Q		REC3852106
440 (TRS)	1983-86	4179554 - B485220	REC57-48122Q		
450	1995-96	F347100 - F347227	REC57-48122Q		REC3852106
460 (TRS)	1983-86	4179554 - 6181046	REC57-48122Q		
502 MAG	1990-97	C878221 - D824588	REC57-48122Q		REC57-13457Q
502 MAG	1990-97	C824589 - K999999	REC57-48122Q		REC3852106
502 MAG (MPI)	1994-97	D840650 - K147349	REC57-48122Q		REC3852106
502 MAG (MPI)	1997	K147350 - K999999	REC57-48122Q		REC57-13457Q
8.2L MIE	1990-93	C878221 - D857199	REC57-48122Q		REC57-13457Q
8.2L MIE	1993-97	D857200 - K999999	REC57-48122Q		REC3852106
8.2L MPI MIE	1996-97	F819620 - K147349	REC57-48122Q		REC3852106
8.2L MPI MIE	1997	K147350 - K999999	REC57-48122Q		REC57-13457Q

GUÍA CORREAS SERPENTÍN MOTOR  
SEPERTINE BELTS GUIDE  
GUIDA CINGHIA A SERPENTINA MOTORE

REF	R.O. OEM	LARGO LENGHT LUNGHEZZA
REC57-865615Q03	57-865615Q03	270,4 cm
REC57-865615Q04	57-865615Q04	194,1 cm
REC57-865615Q06	57-865615Q06	266,7 cm
REC57-865615Q07	57-865615Q07	246,2 cm
REC57-865615Q08	57-865615Q08	253,5 cm
REC57-865615Q09	57-865615Q09	178,0 cm
REC57-807755Q04	57-807755Q04	224,0 cm
REC57-807755Q05	57-807755Q05	193,0 cm
REC57-861049Q	57-861049Q	264,9 cm
REC57-861757Q	57-861757Q	247,1 cm
REC57-861758Q	57-861758Q	219,7 cm
REC57-861759Q	57-861759Q	235,2 cm
REC57-865615Q01	57-865615Q01	283,0 cm
REC57-865615Q02	57-865615Q02	228,5 cm
REC57-865615Q05	57-865615Q05	223,3 cm
REC57-865615Q10	57-865615Q10	219,5 cm
REC57-817113	57-817113	138,9 cm



ANCHO / WIDTH / LARGHEZZA: 2.06 cm

Modelo Model Modello	Año Year Anno	SERIE SERIAL SERIE	REF	NOTA FOOTNOTE NOTA
4.3L Alpha	1996-99	OF803000-OL618999	REC57-807755Q05	4
4.3L Alpha	1996-99	OF803000-OL618999	REC57-861758Q	2, 6
4.3L Alpha	1996-99	OF803000-OL618999	REC57-861759Q	2, 5
4.3L Alpha	2000-04	OL619000 +	REC57-865615Q04	3, 6, 7
4.3L Alpha	2000-04	OL619000+	REC57-865615Q08	4, 5, 7
4.3L Alpha	2000-04	OL619000+	REC57-865615Q03	3
4.3L Alpha	2000-04	OL619000+	REC57-865615Q09	4, 5, 7
4.3L Bravo	1996-99	OF803000-OL618999	REC57-861049Q	2, 5
4.3L Bravo	1996-99	OF803000-OL618999	REC57-861757Q	2, 6
4.3L Bravo	2000-04	OL619000+	REC57-865615Q08	4, 7
4.3L Bravo	2000-04	OL619000+	REC57-865615Q03	3
5.0L Bravo	2002-04	OM600000+	REC57-865615Q06	3, 5, 7
5.0L Alpha	1998-99	OL012052-OL618999	REC57-807755Q05	4, 6
5.0L Alpha	1998-99	OL012052-OL618999	REC57-861049Q	5
5.0L Alpha	1998-99	OL012052-OL618999	REC57-861758Q	2, 6
5.0L Alpha	2000-04	OL619000+	REC57-865615Q06	3, 6, 7
5.0L Alpha	2000-04	OM600000+	REC57-865615Q06	3, 5, 7
5.0L Alpha	2001-04	OL619000+	REC57-865615Q08	4, 5, 7
5.0L Alpha	2001-04	OL619000+	REC57-865615Q03	3
5.0L Alpha	2000-04	OL619000+	REC57-865615Q09	4, 6, 7
5.0L Bravo	1998-99	OL012052-OL618999	REC57-861049Q	2, 5
5.0L Bravo	1998-99	OL012052-OL618999	REC57-861757Q	2, 6

Modelo Model Modello	Año Year Anno	SERIE SERIAL SERIE	REF	NOTA FOOTNOTE NOTA
5.0L Bravo	2000-04	OL619000+	REC57-865615Q08	4, 7
5.0L Bravo	2000-04	OL619000+	REC57-865615Q03	3
350 Mag, Alpha	1997-04	OK001501-OL618999	REC57-807755Q05	4, 6
350 Mag, Alpha	1997-04	OK001501-OL618999	REC57-861049Q	2, 5
350 Mag, Alpha	1997-04	OK001501-OL618999	REC57-861758Q	2, 6
350 Mag, Alpha	2000-04	OL619000+	REC57-865615Q07	3, 6, 7
350 Mag, Alpha	2002-04	OM600000+	REC57-865615Q06	3, 5, 7
350 Mag, Alpha	2000-04	OL619000+	REC57-865615Q08	4, 5, 7
350 Mag, Alpha	2000-04	OL619000+	REC57-865615Q03	3
350 Mag, Alpha	2000-04	OL619000+	REC57-865615Q09	4, 6, 7
350 Mag, Bravo	1997-04	OK001501-OL618999	REC57-861049Q	2, 5
350 Mag, Bravo	1997-04	OK001501-OL618999	REC57-861757Q	2, 6
350 Mag, Bravo	2002-04	OM600000+	REC57-865615Q06	3, 5, 7
350 Mag, Bravo	2000-04	OL619000+	REC57-865615Q08	4, 7
350 Mag, Bravo	2000-04	OL619000+	REC57-865615Q03	3
5.7L Alpha	1997-99	OK001501-OL618999	REC57-807755Q05	4, 6
5.7L Alpha	1997-99	OK001501-OL618999	REC57-861049Q	2, 5
5.7L Alpha	1997-99	OK001501-OL618999	REC57-861758Q	2, 6
5.7L Alpha	2000-04	OL619000+	REC57-865615Q08	3, 6, 7
5.7L Alpha	2000-04	OL619000+	REC57-865615Q03	3
5.7L Alpha	2000-04	OM600000+	REC57-865615Q06	3, 5, 7
5.7L Alpha	2000-04	OL619000+	REC57-865615Q08	3, 6, 7
5.7L Alpha	2000-04	OL619000+	REC57-865615Q03	3
5.7L Alpha	2000-04	OL619000+	REC57-865615Q09	4, 6, 7
5.7L Bravo	1997-99	OK001501-OL618999	REC57-861049Q	2, 5
5.7L Bravo	1997-99	OK001501-OL618999	REC57-861757Q	2, 6
5.7L Bravo	2002-04	OM600000+	REC57-865615Q06	3, 5, 7
5.7L Bravo	2000-04	OL619000+	REC57-865615Q08	4, 7
5.7L Bravo	2000-04	OL619000+	REC57-865615Q03	3
5.7L Ski	1997-02	K040004-M316999	REC57-807755Q04	
377 Scorpion MCM	1999-04	OL416146+	REC57-861757Q	
377 Scorpion Ski	1997-98	K000656+	REC57-807755Q04	
454 Mag MPI	1998-01	OL010029-OM024999	REC57-861049Q	1
454 Mag MPI	1998-01	OL010029-OM024999	REC57-865615Q06	2
454 Mag MPI	1998-01	OL010029-OM024999	REC57-865615Q07	4
454 Mag MPI Horizon MIE	1998-01	OL002200-OL674000	REC57-865615Q07	
496 Mag & HO	2000-04	OM025000+	REC57-865615Q01	
500 EFI	1999-04	L001477+	REC57-807755Q04	
502 Mag MPI	1998-01	OL017000-OM024999	REC57-861049Q	1
502 Mag MPI	1998-01	OL017000-OM024999	REC57-865615Q07	4
502 Mag MPI	1998-01	OL017000-OM024999	REC57-865615Q06	2
525 EFI	2003-04	OM900146+	REC57-865615Q02	
525 SC	1991-96	OD456000-745215	REC57-817113	
575 SCI	2000-04	OL306696+	REC57-807755Q04	9
575 SCI	2000-04	OL306696+	REC57-817113	8
600 SC	1991-96	OD456489 - OF877462	REC57-817113	
600 SC	1998	OK000227+	REC57-817113	
7.4L MPI	1998-01	OL010003-OM024330	REC57-861049Q	1
7.4L MPI	1998-01	OL010003-OM024330	REC57-865615Q06	2
7.4L MPI	1998-01	OL010003-OM024330	REC57-865615Q07	4
7.4L MPI MIE	1998-01	OL002006-OM025999	REC57-865615Q07	
Black Scorpion Ski	1997-01	K040004-M316999	REC57-807755Q04	
MX 6.2L Blk Scorpion Ski	2001	L670015-M391599	REC57-807755Q04	
MX 6.2L MPI	2002-04	OM600000+	REC57-865615Q06	3, 5
MX 6.2L MPI	2000-04	OL680003+	REC57-865615Q08	4, 7
MX 6.2L MPI Horizon	2002-04	OM600000+	REC57-865615Q06	3
MX 6.2L MPI Horizon	2001-04	OM300000+	REC57-865615Q08	4
MX 6.2L MPI Horizon MIE	2001	M300000-M310099	REC57-807755Q04	
MX 6.2L MPI MIE	1999-01	L670000-M310099	REC57-807755Q04	
8.1S MPI MIE & HO	2000-04	OM025000+	REC57-865615Q02	
8.2L MPI MIE	1998-01	OL002450-OL674200	REC57-865615Q07	

**NOTA**

- 1 usar con polea bomba de plástico Ø 4-3/4"
- 2 usar con polea bomba de metal Ø 4-3/4"
- 3 para motores con dirección hidráulica
- 4 Para motores sin dirección hidráulica
- 5 para motores con circuito de refrigeración cerrado
- 6 para motores con refrigeración standard
- 7 Para motores con alternadores montads en alto
- 8 Intercambiador
- 9 Alternador

**FOOTNOTE**

- 1 Use w/ plastic 4-3/4" Ø p/s pump pulley
- 2 Use with metal 5-3/4"Ø p/s pump pulley
- 3 For engines with power steering
- 4 For engines without power steering
- 5 For engines with closed cooling
- 6 For engines with standard cooling
- 7 Engines with high mounted alternators
- 8 Blower
- 9 Alternator

**NOTA**

- 1 Usare con puleggia pompa in plastica Ø 4-3/4"
- 2 Usare con puleggia pompa in metallo Ø 4-3/4"
- 3 Per motori con pompa idroguida
- 4 per motori senza pompa idroguida
- 5 per motori con circuito d'acqua chiuso
- 6 Per motori con circuito aperto
- 7 Per motori con alternatori montati nella parte superiore
- 8 Scambiatore
- 9 Alternatore

# MANGUITOS MOTOR HOSES MANICOTTO MOTORE

## TOMA DE AGUA WATER SYSTEM PRESA ACQUA

Ref.	R.O. OEM	Ø	LONGITUD LENGHT LUNGHEZZA
REC32-4172533	32-4172533 32-8M0062309	3/4"	137/8"
REC32-32461	32-32461 32-32461A1	5/8"	137/8"



Ref.	R.O. OEM
REC32-52481	32-52481

**MOTORES / ENGINES / MOTORI**  
GM 4 & 6 CYL Inline



Ref.	R.O. OEM
REC32-43437	32-43437

**MOTORES / ENGINES / MOTORI**  
Bravo Design I



Ref.	R.O. OEM
REC8M0062102	32-8M0062102

**MOTORES / ENGINES / MOTORI**  
Bravo Design II



## BOMBA DE AGUA WATER PUMP POMPA ACQUA

Ref.	R.O. OEM
RM32-805375	32-805375



Ref.	R.O. OEM
REC32-33189	32-33189

**MOTORES / ENGINES / MOTORI**  
1 3/4" ID  
12 3/4"



Ref.	R.O. OEM
REC32-897181	32-897181



## BOMBA DE AGUA A ENFRIADOR DE ACEITE MOLDED SEAWATER PUMP TO OIL COOLER

**DALLA POMPA DELL'ACQUA ALLO  
SCAMBIATORE DELL'OLIO**

Ref.	R.O. OEM
REC32-88795	32-88795



Ref.	R.O. OEM
REC32-860205	32-860205



Ref.	R.O. OEM
REC32-887952	32-887952



Ref.	R.O. OEM
REC32-8080441	32-808044-1



## CULATA A COLECTOR ESCAPE CYLINDER HEAD TO EXHAUST MANIFOLD DALLA TESTATA AL COLLETTORE DI SCARICO

Ref.	R.O. OEM
REC32-89653	32-89653

**MOTORES / ENGINES / MOTORI**  
1 1/4" ID  
5"



## CUERPO TERMOSTATO A BOMBA AGUA DISTRIBUTION BLOCK TO WATER PUMP CORPO TERMOSTATO ALLA POMPA DELL'ACQUA

Ref.	R.O. OEM
REC32-8M0071007	32-96879 32-47640 32-8M0071007

**MOTORES / ENGINES / MOTORI**  
3.0L





**ENFRIADOR DE ACEITE  
A ENFRIADOR DE ACEITE  
HOSE OIL COOLER TO OIL COOLER  
SCAMBIATORE DELL'OLIO A  
SCAMBIATORE DELL'OLIO**

Ref.	R.O. OEM
REC32-8600891	32-8600891



**CUERPO TERMOSTATO  
A COLECTOR (DELANTERO)  
THERMOSTAT TO MANIFOLD (FRONT)  
CORPO TERMOSTATO AL  
COLLETTORE (FRONTALE)**

Ref.	R.O. OEM
REC32-48132	32-48132



**CUERPO TERMOSTATO  
A COLECTOR ESTRIBOR  
THERMOSTAT HOUSING TO  
STARBOARD EXHAUST MANIFOLD  
CORPO TERMOSTATO AL  
COLLETTORE DESTRO**

Ref.	R.O. OEM
REC32-871171	32-87117 1 32-87117



Ref.	R.O. OEM
REC32-807697	32-807697



Ref.	R.O. OEM
REC32-897301	32-897301



Ref.	R.O. OEM
REC32-8066361	32-8066361



Ref.	R.O. OEM
REC32-8066351	32-8066351



Ref.	R.O. OEM
RM32-861057	32-861057



Ref.	R.O. OEM
RM32-861058	32-861058



**CUERPO TERMOSTATO  
A COLECTOR BABOR  
THERMOSTAT HOUSING TO PORT  
EXHAUST MANIFOLD  
CORPO TERMOSTATO AL  
COLLETTORE SINISTRO**

Ref.	R.O. OEM
REC32-160211	32-16021 1



Ref.	R.O. OEM
REC32-33220	32-33220 32-3322070 32-8M0062614



Ref.	R.O. OEM
REC32-897491	32-89749-1



Ref.	R.O. OEM
REC32-862139	32-862139



Ref.	R.O. OEM
REC32-52481	32-52481



Ref.	R.O. OEM
REC32-862124	32-862124



Ref.	R.O. OEM
RM32-860144	32-860144



Ref.	R.O. OEM
RM32-860331	32-860331



**TRANSOM A ENFRIADOR ACEITE**  
**TRANSOM TO OIL COOLER**  
**TRANSOM A SCAMBIATORE DELL'OLIO**

Ref.	R.O. OEM
REC32-807661	32-807661



Ref.	R.O. OEM
REC32-96246A4	32-96246A4



**ENFRIADOR A CUERPO**  
**TERMOSTATO**  
**HOSE COOLER TO THERMOSTAT**  
**HOUSING**  
**SCAMBIATORE A CORPO**  
**TERMOSTATO**

Ref.	R.O. OEM
REC32-806856	32-806856



Ref.	R.O. OEM
REC32-807407	32-807407



Ref.	R.O. OEM
REC32-808033	32-808033



Ref.	R.O. OEM
RM32-806209-1	32-806209-1



Ref.	R.O. OEM
REC32-16012	32-16012



**GUÍA MANGUITOS (COLA)**  
**HOSES FUEL GUIDE (STERN DRIVES)**  
**GUIDA MANICOTTO (PIEDE)**



Modelo Modello	SERIE SERIAL SERIE	TERMOSTATO A BOMBA THERMOSTAT TO PUMP TERMOSTATO A POMPA	TERMOSTATO A COLECTOR ESCAPE ESTRIBOR THERMOSTAT TO MANIFOLD STB TERMOSTATO A COLLETTORE SCARICO DESTRO	TERMOSTATO A COLECTOR ESCAPE BABOR THERMOSTATTO MANIFOLD PORT TERMOSTATO A COLLETTORE SCARICO SINISTRO	TERMOSTATO A COLECTOR ESCAPE THERMOSTAT TO MANIFOLD TERMOSTATO A COLLETTORE SCARICO	TRANSOM AENFRIADOR ACEITE TRANSOM TO OIL COOLER TRANSOM A SCAMBIATORE DELL'OLIO	TERMOSTATO A ENFRIADOR ACEITE THERMOSTAT TO OIL COOLER TERMOSTATO A SCAMBIATORE DELL'OLIO	BOMBA A ENFRIADOR ACEITE WATER PUMP TO OIL COOLER POMPA A SCAMBIATORE DELL'OLIO
120	1666601-3377340	REC32-8M0071007			REC32-52481			
120	3377341-5192048	REC32-8M0071007			REC32-52481			
120	5192049-6229717	REC32-8M0071007			REC32-52481			
120/2,5L	6229718-0B531853	REC32-8M0071007			REC32-52481			
140	2508261-3332137	REC32-8M0071007			REC32-52481			
140	3332138-5157669	REC32-8M0071007			REC32-52481			
140	5157669-6229717	REC32-8M0071007			REC32-52481			
140/3.OL	6229718-0C856558	REC32-8M0071007			REC32-52481			
3.0L/LX	0C856559-0F603999	REC32-8M0071007			REC32-52481			
3.0LX	0G604000+	REC32-8M0071007			REC32-52481			
140	1538930-1725960	REC32-8M0071007			REC32-52481			
488 (4bbl)	6170297-6916778						REC32-33220	

Modelo Modelo	SERIE SERIAL SERIE	TERMOSTATO A BOMBA THERMOSTAT TO PUMP TERMOSTATO A POMPA	TERMOSTATO A COLECTOR ESCAPE ESTRIBOR THERMOSTAT TO MANIFOLD STB TERMOSTATO A COLLETTORE SCARICO DESTRO	TERMOSTATO A COLECTOR ESCAPE BABOR THERMOSTATO MANIFOLD PORT TERMOSTATO A COLLETTORE SCARICO SINISTRO	TERMOSTATO A COLECTOR ESCAPE THERMOSTAT TO MANIFOLD TERMOSTATO A COLLETTORE SCARICO	TRANSOM AENFRIADOR ACEITE TRANSOM TO OIL COOLER TRANSOM A SCAMBIATORE DELL'OLIO	TERMOSTATO A ENFRIADOR ACEITE THERMOSTAT TO OIL COOLER TERMOSTATO A SCAMBIATORE DELL'OLIO	BOMBA A ENFRIADOR ACEITE WATER PUMP TO OIL COOLER POMPA A SCAMBIATORE DELL'OLIO
190 (4bbl)	6916779+						REC32-33220	
180/3.7LX (4bbl)	6916779+						REC32-33220	
185 (4bbl)	6330183-6919655	REC32-33189						
165	2770032-5178958				REC32-52481			
165	5178959-5813433				REC32-52481			
185 (2bbl)	0A331455-0B527954	REC32-33189					REC32-33220	
175/4.3 (2bbl)	0B527955-0D714106	REC32-33189					REC32-33220	
4.3L (GEN II) (2bbl)	0D714107-0F00877	REC32-33189	REC32-871171	REC32-160211			REC32-806856	
4.3L (GEN II) (2bbl)	0F000878-0F601126		REC32-8066361	REC32-8066351		REC32-806856		
4.3L (GEN II) (2bbl)	0F601127-0F802999	REC32-33189	REC32-8066361	REC32-8066351		REC32-806856		REC27-68714A6
4.3LX (GEN+) (2bbl)	0F803000+	REC32-33189	REC32-807697	RM32-860144			REC32-16012	REC27-68714A6
205 (4bbl)	0A331455-0B527954	REC32-33189	REC32-871171				REC32-16012	
205/4.3LX (4bbl)	0B527955-0D714639	REC32-33189					REC32-16012	
4.3L (GEN II) (2bbl)	0D714370-0F001219	REC32-33189				REC32-807661	REC32-16012	
4.3L (GEN II) (2bbl)	0F001220-0F601126	REC32-33189	REC32-8066361	REC32-8066351	REC32-807661	REC32-16012		
4.3L (GEN II) (2bbl)	0F601127-0F802999	REC32-33189	REC32-8066361	REC32-8066351	REC32-807661	REC32-16012		
4.3LXH (GEN+) (4bbl)	0F803114+	REC32-33189	REC32-807697	RM32-860144		REC32-807661	REC32-16012	REC32-860205
200	2453769-2712072				REC32-52481			
225 (4bbl)	3385721-4166999	REC32-33189						
225-S (4bbl)	3385721-416999	REC32-33189						
200 (2bbl)	6218462-0B525981	REC32-33189	REC32-871171	REC32-160211		REC32-96246A4	REC32-806856	REC27-68714A6
200/5.0L (2bbl)	0B525982-0F600999	REC32-33189	REC32-8066361	REC32-8066351	REC32-96246A4	REC32-806856	REC32-887952	
230 (4bbl)	6218462-0B525981	REC32-33189	REC32-871171	REC32-160211		REC32-96246A4	REC32-806856	REC27-68714A6
230/5.0LX (4bbl)	0B525982-0F600999	REC32-33189	REC32-8066361	REC32-8066351	REC32-96246A4	REC32-806856	REC32-887952	
250	4768000-4908849	REC32-33189	REC32-871171					
260	6218462-0B525981	REC32-33189				REC32-96246A4	REC32-806856	REC27-68714A6
260	6218462-0B525981	REC32-33189				REC32-96246A4		
260/5.7L	0B525982-0F600999	REC32-33189	REC32-8066361	REC32-8066351	REC32-96246A4	REC32-806856	REC32-887952	
5.7 ALPHA (2bbl)	0F601000+	REC32-33189	REC32-8066361	REC32-8066351	REC32-807661	REC32-806856	REC32-887952	
5.7L ALPHA (EFI) TBI	0F355305-0F752399	REC32-33189	REC32-8066361	REC32-8066351	REC32-96246A4	REC32-806856	REC32-887952	
5.7L ALPHA (2bbl. -TBI)	0F752400+	REC32-33189	REC32-8066361	REC32-8066351	REC32-807661	REC32-806856	REC32-887952	
5.7LX ALPHA (4bbl)	0F601000+	REC32-33189	REC32-8066361	REC32-8066351		REC32-806856	REC32-887952	
5.7LX ALPHA (4bbl. -TBI)	0F752400+	REC32-33189	REC32-807697	REC32-8066351		REC32-806856	REC32-887952	
5.7L BRAVO	0B525982-0F600999							REC32-887952
5.7L BRAVO (2bbl)	0F601000+							REC32-887952
5.7L BRAVO (EFI) TBI	0F225560-0F752399		REC32-8066361	REC32-8066351		REC32-96246A4	REC32-806856	REC32-887952
5.7L BRAVO (2bbl.-TBI)	0F752400+	REC32-33189	REC32-807697	REC32-8066351				REC32-887952
5.7LX BRAVO (4bbl)	0F601000+		REC32-8066361	REC32-8066351				REC32-887952
5.7LX BRAVO (4bbl.-TBI)	0F752400+	REC32-33189	REC32-807697	REC32-8066351				REC32-887952
5.7LX BRAVO (TBI) (GEN +)	0F800300+	REC32-33189	REC32-8066351	REC32-8066351			REC32-806856	REC32-887952
350 Mag. ALPHA	0A635178-0B525981	REC32-33189	REC32-871171	REC32-160211		REC32-96246A4		REC32-887952
350 Mag. ALPHA	0B525982-0F600999	REC32-33189	REC32-8066361	REC32-8066351		REC32-96246A4	REC32-806856	REC32-887952
350 Mag. ALPHA (4bbl)	0F601000+	REC32-33189	REC32-8066361	REC32-8066351		REC32-807661	REC32-806856	REC32-887952
350 Mag. ALPHA (TBI) (Gen+)	0F800300+	REC32-33189	REC32-8066361	REC32-8066351		REC32-807661	REC32-806856	REC32-887952
350 Mag. BRAVO (MPI)	0F415189-0F601999	REC32-33189	REC32-8066361	REC32-8066351		REC32-807661	REC32-806856	REC32-887952
350 Mag BRAVO (MPI)(GEN+)	0F602000+	REC32-33189	REC32-8066361	REC32-8066351		REC32-807661	REC32-806856	REC32-887952
270	2851074-3385720							
300 TEMPEST	6668677-0B430367	REC32-33189				REC32-96246A4		
320 (EFI)	0A543604-0B157602	REC32-33189				REC32-96246A4		
320 (EFI)	0B157603-0C622418	REC32-33189				REC32-96246A4		
325	2278747-3780449							
330	4623115-6083144				REC32-48132			
330	6083145-0B816540		REC32-897301	REC32-897491	REC32-48132			
7.4L BRAVO	0B771113-0D603117		REC32-52481	REC32-897491				
7.4LX BRAVO (Gen.V)	0D603118-0F800699	REC32-897181	REC32-897301	REC32-897491				
7.4LX BRAVO (MP)	0F602010+	REC32-897181	REC32-807697	REC32-897491				
450 Mag. ALPHA	0A631894-0B785148		REC32-897301	REC32-897491		REC32-96246A4		
454 Mag. BRAVO	0B721206-0D805068		REC32-897301	REC32-897491				
454 Mag. BRAVO (Gen.V)	0D805069-0F304999	REC32-897181	REC32-807697	REC32-897491				
454 Mag. BRAVO (Gen.V)	0F305000-0F801699	REC32-897181	REC32-897301	REC32-897491				

Modelo Model Modello	SERIE SERIAL SERIE	TERMOSTATO A BOMBA THERMOSTAT TO PUMP TERMOSTATO A POMPA	TERMOSTATO A COLECTOR ESCAPE ESTRIBOR THERMOSTAT TO MANIFOLD STB TERMOSTATO A COLLETTORE SCARICO DESTRO	TERMOSTATO A COLECTOR ESCAPE BAVOR THERMOSTATO MANIFOLD PORT TERMOSTATO A COLLETTORE SCARICO SINISTRO	TERMOSTATO A COLECTOR ESCAPE THERMOSTAT TO MANIFOLD TERMOSTATO A COLLETTORE SCARICO	TRANSOM AENFRIADOR ACEITE TRANSOM TO OIL COOLER TRANSOM A SCAMBIATORE DELL'OLIO	TERMOSTATO A ENFRIADOR ACEITE THERMOSTAT TO OIL COOLER TERMOSTATO A SCAMBIATORE DELL'OLIO	BOMBA A ENFRIADOR ACEITE WATER PUMP TO OIL COOLER POMPA A SCAMBIATORE DELL'OLIO
454 EFI (Gen.V)	0F115700-0F802349	REC32-897181						
370TRS	4179554-6721527				REC32-48132			
370TRS	6721528-0B714586		REC32-807697	REC32-897491				
400TRS	4179554-0B457644				REC32-48132			
420	0A398941-0B622418	REC32-897181						
425	0A398941-0B622418	REC32-897181						
425 (Gen.V)	0A398941-0B622418	REC32-897181						
440TRS	4179554-0B485220				REC32-48132			
450 (Gen.V)	0F347100-0F615761	REC32-897181	REC32-897301	REC32-897491				
460 TRS	4179554-6181046				REC32-48132			
465	0C84992-0F213244	REC32-897181						
465 (Gen.V)	0C84992-0F213244	REC32-897181						
500 (Gen.V)	0F213293+	REC32-897181	REC32-897301	REC32-897491				
502 Mag. BRAVO	0C878221-0D824588	REC32-897181	REC32-897301	REC32-897491				
502 Mag. BRAVO (Gen.V)	0D824589-0F114528	REC32-897181	REC32-897301	REC32-897491				
502 EFI (Gen.V)	0D840650-0F802599	REC32-897181	REC32-897301	REC32-897491				

**GUÍA MANGUITOS (EJE - GASOLINA)  
HOSES GUIDE (SHAFT - FUEL)  
GUIDA MANICOTTO (ASSE - BENZINA)**



Modelo Model Modello	SERIE SERIAL SERIE	TERMOSTATO A BOMBA THERMOSTAT TO PUMP TERMOSTATO A POMPA	TERMOSTATO A COLECTOR ESCAPE ESTRIBOR THERMOSTAT TO MANIFOLD STB TERMOSTATO A COLLETTORE SCARICO DESTRO	TERMOSTATO A COLECTOR ESCAPE BAVOR THERMOSTATO MANIFOLD PORT TERMOSTATO A COLLETTORE SCARICO SINISTRO	TERMOSTATO A COLECTOR ESCAPE THERMOSTAT TO MANIFOLD TERMOSTATO A COLLETTORE SCARICO	TRANSOM AENFRIADOR ACEITE TRANSOM TO OIL COOLER TRANSOM A SCAMBIATORE DELL'OLIO	TERMOSTATO A ENFRIADOR ACEITE THERMOSTAT TO OIL COOLER TERMOSTATO A SCAMBIATORE DELL'OLIO	BOMBA A ENFRIADOR ACEITE WATER PUMP TO OIL COOLER POMPA A SCAMBIATORE DELL'OLIO
470 MIE	5520115-6218036							
215 MIE	2781153-3563181							
225 MIE	3385721-4176999							
198 MIE (2bbl.)	4762210-6218461	REC32-33189			REC32-48132			
228 MIE (4bbl.)	4765100-5170008	REC32-33189			REC32-48132			
228 MIE (4bbl.)	5170009-5907057	REC32-33189						
230 MIE (4bbl.)	5907058-0B522505	REC32-33189			REC32-48132			
230/5.0L MIE (4bbl.)	0B522506-0B788151	REC32-33189			REC32-48132		REC27-68714A6	
225MIE	2278647-2694014				REC32-33189		REC27-68714A6	
250 MIE	2314301-2639854	REC32-33189			REC32-33189			
255 MIE	4175500-5195908	REC32-33189			REC32-33189			
255 MIE	5195909-5907057	REC32-33189			REC32-48132			
260 MIE	5900758-0B522505	REC32-33189			REC32-48132		REC27-68714A6	
260/5.7 MIE	0B522506-0F024999	REC32-33189			REC32-48132		REC27-68714A6	
5.7L MIE	0F025000+	REC32-33189	REC32-871171		REC32-33189	REC32-806856		
5.7L MIE	0F622100-0F622150 0F746100+							
5.7L (SKI) MIE	0A338533-0B514626	REC32-33189						
5.7L (COMP. SKI)	0B514627-0F775199	REC32-33189	REC32-871171					
5.7l (COMP. SKI) (2bbl.)	0F775200+	REC32-33189	REC32-8066361	REC32-8066351		REC32-806856		
350 Mag. (SKI) CARB	0D505450+	REC32-33189	REC32-871171			REC32-806856	REC32-860205	
350 Mag. (SKI) (9EFI)TBI	0F215561+	REC32-33189	REC32-8066361	REC32-8066351		REC32-806856	REC32-860205	
350 Mag. (SKI) (9EFI)MPI	0F350583+	REC32-33189	REC32-8066361	REC32-8066351			REC32-860205	
BLACK SCORPION (GEN+)	0F800000+		REC32-807697	REC32-8066351		REC32-806856	REC32-860205	REC32-8600891
270 MIE	2851074-3077735	REC32-33189						
233 MIE	4173000-4775784							
255 MIE	3258728-4178299							
325 MIE	2278747-3780449				REC32-48132			
330 MIE	4623115-5889913				REC32-48132			
7.4L MIE w/hurth	0C391564-0D715493	REC32-897181	REC32-897301	REC32-897491				
7.4L MIE (lh) Gen.V	0D715494-0F820141	REC32-897181	REC32-897301	REC32-897491				
7.4L EFI MIE (LH) Gen.V	0F563052-0F820103	REC32-897181						
454 EFI (SKI) (Gen.V)	0F215800-0F820099							
350 MIE	3780450-4623109							
390 MIE	2781129-2820559				REC32-48132			
8.2L MIE w/hurth	0C878221-0D857199	REC32-897181	REC32-897301	REC32-897491				
8.2L MIE (Gen.V)	0D857200-0F819619	REC32-897181	REC32-897301	REC32-897491				

GUÍA MANGUITOS  
HOSES GUIDE  
GUIDA MANICOTTO



Modelo Model Modello	SERIE SERIAL SERIE	TERMOSTATO A BOMBA THERMOSTAT TO PUMP TERMOSTATO A POMPA
530D-TA(BRAVO)	0B993002-0D725151	RM32-805375
D183 Turbo AC (BRAVO)	0B993002-0D725151	RM32-805375
D3.0L (BRAVO)	0D725152+	RM32-805375
636D-TA (BRAVO)	0B993002-0D850127	RM32-805375
D219 Turbo AC (BRAVO)	0B993002-0D850127	RM32-805375
D3.6L (BRAVO)	0D850128+	RM32-805375
D254 Turbo AC (BRAVO)	0C849461-0D554731	
D4.2L (BRAVO)	0D554732+	RM32-805375
7.3L (BRAVO)	0F060048+	
530D-TA	0B993002-0D725151	
D183 Turbo AC	0B993002-0D725151	
D3.0L	0D725152+	RM32-805375
636D-TA	0B993002-0D850127	

INTERCAMBIADORES  
DE CALOR  
HEAT EXCHANGERS  
SCAMBIATORI DI CALORE

Ref.	R.O. OEM
RM99438A1	99438A1

Para saber cual es la ref. que comprende a su motor, informar del modelo de motor y n° de serie  
To know which is the model you need, please inform the model and serial number of the engine.

Per sapere il modello corretto, fornire all'assistenza clienti il numero di serie del motore.



ENFRIADOR ACEITE  
OIL COOLER  
REFRIGERANTE  
DELL'OLIO

Ref.	R.O. OEM
RM807371T1	807371T1
REC99356A2	99356A2
RM99356A1	99356A1
REC89690T	89690T

Para saber cual es la ref. que comprende a su motor, informar del modelo de motor y n° de serie  
To know which is the model you need, please inform the model and serial number of the engine.

Per sapere il modello corretto, fornire all'assistenza clienti il numero di serie del motore.



KITS BOTELLAS ACEITE  
RESERVOIR  
ASSEMBLIES KITS  
KIT BOTTIGLIA OLIO

Ref.	R.O. OEM
RM806193A48	806193A48
	806193A38
	806193A20
	19742A1
	19742A3

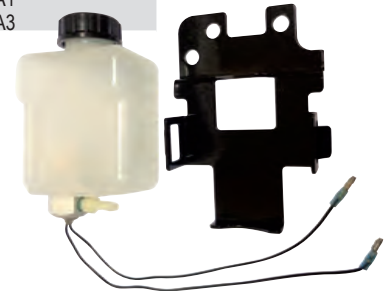

Ref.	R.O. OEM
REC22-861150T02	22-861150T02
	22-861150A1
	22-861150A2



RACORD 90° PASO ACEITE  
OIL RACOR 90°  
RACORDO 90° PASSO OLIO

Ref.	R.O. OEM
RM22-861163	22-861163

Se instala en / It is installed in / Installato in:  
REC22-861150T02



CIRCLIP  
CIRCLIP  
CLIP

Ref.	R.O. OEM
RM53-87843	53-87843

Se instala en / It is installed in / Installato in:  
REC22-861150T02









# GUÍA MANTENIMIENTO MOTORES

## ENGINE MAINTENANCE GUIDE

### GUIDA MANUTENZIONE MOTORI

Modelo Model Modello	DESCRIPCIÓN	DESCRIPTION	DESCRIZIONE	Unds. Units Unità	Ref.
3.0L GM181 I/L4 1987+ (0B450801+)	BUJIA (-0L096999)	SPARK PLUG (-0L96999)	CANDELE (-0L096999)	4	NGKBR6FS
	BUJIA (0L097000+)	SPARK PLUG (0L96700+)	CANDELE (0L96700+)	4	NGKBPR6EFS
	CORREA ALTERNADOR CON DIRECCION HIDRAULICA (-0L382121)	ALTERNATOR BELT WITH HYDRAULIC STEERING (-0L382121)	CINGHIA ALTERNATORE CON STERZO IDRAULICO (-0L382121)	1	REC3852106
	CORREA ALTERNADOR CON DIRECCION HIDRAULICA (0L382122+)	ALTERNATOR BELT WITH HYDRAULIC STEERING (0L382122+)	CINGHIA ALTERNATORE CON STERZO IDRAULICO (0L382122+)	1	RM57-862054Q
	CORREA ALTERNADOR SIN DIRECCION HIDRAULICA	ALTERNATOR BELT WITHOUT HYDRAULIC STEERING	CINGHIA ALTERNATORE SENZA STERZO IDRAULICO	1	REC57-49043A1
	CORREA DIRECCION HIDRAULICA	HYDRAULIC STEERING BELT	CINGHIA STERZO IDRAULICO	1	REC57-65607Q
	TERMOSTATO (-0L340999)	THERMOSTAT (-0L340999)	TERMOSTATO (-0L340999)	1	REC59078Q3
	TERMOSTATO (0L341000+) & TODOS ENFRIADOR CERRADO	THERMOSTAT (0L341000+) & ALL CLOSED COOLING	TERMOSTATO (0L341000+) E TUTTI RAFFREDDAMENTO CHIUSO	1	REC8M0091470
	FILTRO ACEITE	OIL FILTER	FILTRO OLIO	1	REC35-06003
	ACEITE MOTOR	OIL	OLIO MOTORE	1	RM92-8M0086224U3
	3.0LX GM181I/L4 (1990-1997) (0C856569 - 0K999999)	BUJIA (-0F603999)	SPARK PLUG (-0F603999)	CANDELE (-0F603999)	4
BUJIA (0F604000+)		SPARK PLUG (0F604000+)	CANDELE (0F604000+)	4	NGKBPR6EFS
CORREA ALTERNADOR (1 POLEA GROVE)		ALTERNATOR BELT (1 GROVE PULLEY)	CINGHIA ALTERNATORE (1 PULEGGIA GROVE)	1	REC57-49043A1
CORREA ALTERNADOR (3 POLEAS GROVE)		ALTERNATOR BELT (3 GROVE PULLEY)	CINGHIA ALTERNATORE (3 PULEGGIA GROVE)	1	REC3852106
TERMOSTATO		THERMOSTAT	TERMOSTATO	1	REC59078Q3
TERMOSTATO ENFRIADOR CERRADO		THERMOSTAT CLOSED COOLING	TERMOSTATO RAFFREDDAMENTO CHIUSO	1	REC8M0091470
CORREA DIRECCION HIDRAULICA		HYDRAULIC STEERING BELT	CINGHIA STERZO IDRAULICO	1	REC57-65607Q
FILTRO ACEITE		OIL FILTER	FILTRO OLIO	1	REC35-06003
ACEITE MOTOR		OIL	OLIO MOTORE	1	RM92-8M0086224U3
3.0 MPI EC (1A072812+)	BUJIA	SPARK PLUG	CANDELE	4	NGKTR6IX
	CORREA ALTERNADOR	ALTERNATOR BELT	CINGHIA ALTERNATORE	1	RM57-862054Q
	TERMOSTATO	THERMOSTAT	TERMOSTATO	1	REC8M0091470
	CORREA DIRECCION HIDRAULICA (940 mm)	HYDRAULIC STEERING BELT (940 mm)	CINGHIA STERZO IDRAULICO (940 mm)	1	REC57-65607Q
	FILTRO ACEITE	OIL FILTER	FILTRO OLIO	1	REC35-06003
	FILTRO GASOLINA	FUEL FILTER	FILTRO BENZINA	1	RM35-866594Q01
	ACEITE MOTOR	OIL	OLIO MOTORE	1	RM92-8M0086227U3
3.0L TKS Plus (1G404114)	BUJIA	SPARK PLUG	CANDELE	4	NGKBPR6EFS
	CORREA ALTERNADOR	ALTERNATOR BELT	CINGHIA ALTERNATORE	1	RM57-862054Q
	TERMOSTATO	THERMOSTAT	TERMOSTATO	1	REC8M0091470
	FILTRO ACEITE	OIL FILTER	FILTRO OLIO	1	REC35-06003
	ACEITE MOTOR	OIL	OLIO MOTORE	1	RM92-8M0086224U3
4.3L (GEN II) (1992-96) (0D714107 - 0F802999)	BUJIA	SPARK PLUG	CANDELE	6	NGKBR6FS
	CORREA ALTERNADOR (46")	ALTERNATOR BELT (46")	CINGHIA ALTERNATORE (46")	1	REC829207
	CORREA DIRECCION HIDRAULICA	HYDRAULIC STEERING BELT	CINGHIA STERZO IDRAULICO	1	REC57-816295Q
	TERMOSTATO 140°	THERMOSTAT 140°	TERMOSTATO 140°	1	REC8M0089715
	TERMOSTATO 160°	THERMOSTAT 160°	TERMOSTATO 160°	1	REC8M0091470
	FILTRO ACEITE	OIL FILTER	FILTRO OLIO	1	REC35-06004
	FILTRO ACEITE (MODELOS CON FILTRO REMOTO)	OIL FILTER (MODELS WITH REMOTE FILTER)	FILTRO OLIO (MODELLI CON FILTRO REMOTO)	1	REC35-06003
	FILTRO GASOLINA	FUEL FILTER	FILTRO BENZINA	1	REC35-802893Q01
	ACEITE MOTOR	OIL	OLIO MOTORE	2	RM92-8M0086227U3
4.3L & LX (GEN +) (1996-98) (0F803000 - 0M614999)	BUJIA	SPARK PLUG	CANDELE	6	NGKBR6FS
	TERMOSTATO 140°	THERMOSTAT 140°	TERMOSTATO 140°	1	REC829207
	TERMOSTATO 160°	THERMOSTAT 160°	TERMOSTATO 160°	1	REC57-816295Q
	FILTRO ACEITE	OIL FILTER	FILTRO OLIO	1	REC8M0089715
	FILTRO ACEITE (FILTRO REMOTO)	OIL FILTER (REMOTE FILTER)	FILTRO OLIO (FILTRO REMOTO)	1	REC8M0091470
	FILTRO GASOLINA	FUEL FILTER	FILTRO BENZINA	1	REC35-06004
	IMPULSOR (BRAVO)	IMPELLER (BRAVO)	GIRANTE (BRAVO)	1	REC35-06003
	ACEITE MOTOR	OIL	OLIO MOTORE	1	REC35-802893Q01
	CORREAS	BELT	CINGHIE		
	4.3L CARB. ALPHA/ BRAVO (0M61500+)	BUJIA	SPARK PLUG	CANDELE	6
TERMOSTATO 140°		THERMOSTAT 140°	TERMOSTATO 140°	1	REC8M0089715
TERMOSTATO 160°		THERMOSTAT 160°	TERMOSTATO 160°	1	REC8M0091470
TERMOSTATO 170° (ENFRIADOR CERRADO)		THERMOSTAT 170° (CLOSED COOLING)	TERMOSTATO 170° (RAFFREDDAMENTO CHIUSO)	1	REC864493
FILTRO ACEITE		OIL FILTER	FILTRO OLIO	1	REC35-06004
FILTRO ACEITE (FILTRO REMOTO)		OIL FILTER (REMOTE FILTER)	FILTRO OLIO (FILTRO REMOTO)	1	REC35-06003
FILTRO GASOLINA		FUEL FILTER	FILTRO BENZINA	1	REC35-802893Q01
IMPULSOR (BRAVO)		IMPELLER (BRAVO)	GIRANTE (BRAVO)	1	REC47-59362Q01
STD ENFRIADOR		STD COOLING	STD RAFFREDDAMENTO	1	REC47-59362Q01
IMPULSOR (BRAVO) ENFRIADOR CERRADO		IMPELLER (BRAVO) CLOSED COOLING	GIRANTE (BRAVO) RAFFREDDAMENTO CHIUSO	1	REC47-862232A2
CORREA ALPHA (DIRECCION ASISTIDA)		ALPHA BELT (POWER STEERING)	CINGHIA ALPHA (SERVOSTERZO)	1	REC57-865615Q04
CORREA ALPHA (DIRECCION HIDRAULICA COMPACTA)		ALPHA BELT (COMPACT HYDRAULIC STEERING)	CINGHIA ALPHA (STERZO IDRAULICO COMPATTO)	1	REC57-865615Q09
CORREA BRAVO (DIRECCION ASISTIDA)		BRAVO BELT (POWER STEERING)	CINGHIA BRAVO (SERVOSTERZO)	1	REC57-865615Q03
CORREA BRAVO (DIRECCION HIDRAULICA COMPACTA)		BRAVO BELT (COMPACT HYDRAULIC STEERING)	CINGHIA BRAVO (STERZO IDRAULICO COMPATTO)	1	REC57-865615Q08
ACEITE MOTOR	OIL	OLIO MOTORE	2	RM92-8M0086227U3	

Modelo Model Modello	DESCRIPCIÓN	DESCRIPTION	DESCRIZIONE	Unds. Units Unità	Ref.
4.3L EFI (GEN+) TBI (0L619000- 0L618999)	BUJIA	SPARK PLUG	CANDELE	6	NGKBPR6EFS
	TERMOSTATO 140°	THERMOSTAT 140°	TERMOSTATO 140°	1	REC8M0089715
	TERMOSTATO 160°	THERMOSTAT 160°	TERMOSTATO 160°	1	REC8M0091470
	FILTRO ACEITE	OIL FILTER	FILTRO OLIO	1	REC35-06004
	FILTRO ACEITE (FILTRO REMOTO)	OIL FILTER (REMOTE FILTER)	FILTRO OLIO (FILTRO REMOTO)	1	REC35-06003
	FILTRO GASOLINA	FUEL FILTER	FILTRO BENZINA	1	REC35-802893Q01
	IMPULSOR (BRAVO)	IMPELLER (BRAVO)	GIRANTE (BRAVO)	1	REC47-59362Q01
	ACEITE MOTOR	OIL	OLIO MOTORE	2	RM92-8M0086227U3
	CORREAS	BELT	CINGHIE		
	4.3L MPI ALPHA/ BRAVO & EC MODELS (ALL SERIES) (OM300000+)	BUJIA	SPARK PLUG	CANDELE	6
TERMOSTATO 140° (STD ENFRIADOR)		THERMOSTAT 140° (STD COOLING)	TERMOSTATO 140° (STD RAFFREDDAMENTO)	1	REC8M0089715
TERMOSTATO 160° (STD ENFRIADOR)		THERMOSTAT 160° (STD COOLING)	TERMOSTATO 160° (STD RAFFREDDAMENTO)	1	REC8M0091470
TERMOSTATO 170° (ENFRIADOR CERRADO)		THERMOSTAT 170° (CLOSED COOLING)	TERMOSTATO 170° (RAFFREDDAMENTO CHIUSO)	1	REC864493
FILTRO ACEITE		OIL FILTER	FILTRO OLIO	1	REC35-06004
FILTRO ACEITE (FILTRO REMOTO)		OIL FILTER (REMOTE FILTER)	FILTRO OLIO (FILTRO REMOTO)	1	REC35-06003
FILTRO GASOLINA		FUEL FILTER	FILTRO BENZINA	1	REC35-802893Q01
IMPULSOR (BRAVO)		IMPELLER (BRAVO)	GIRANTE (BRAVO)	1	REC47-862232A2
ACEITE MOTOR		OIL	OLIO MOTORE	2	RM92-8M0086227U3
CORREAS		BELT	CINGHIE		
4.5L MPI ALPHA/ BRAVO (2A441953+)	BUJIA	SPARK PLUG	CANDELE	6	NGKBPR5EFS-13
	TERMOSTATO 170° (INTERCAMBIADOR DE CALOR)	THERMOSTAT 170° (HEAT EXCHANGER)	TERMOSTATO 170° (SCAMBIATORE DI CALORE)	1	REC864493
	TERMOSTATO 140°	THERMOSTAT 140°	TERMOSTATO 140°	1	REC8M0089715
	FILTRO ACEITE	OIL FILTER	FILTRO OLIO	1	REC35-06003
	FILTRO GASOLINA	FUEL FILTER	FILTRO BENZINA	1	RAC31871
	IMPULSOR (BRAVO)	IMPELLER (BRAVO)	GIRANTE (BRAVO)	1	REC47-862232A2
	ACEITE MOTOR	OIL	OLIO MOTORE	2	RM92-8M0086227U3
	CORREAS	BELT	CINGHIE		
5.0L (1988-95) (0B774445 - 0F600999)	BUJIA	SPARK PLUG	CANDELE	8	NGKBR6FS
	TERMOSTATO 140°	THERMOSTAT 140°	TERMOSTATO 140°	1	REC8M0089715
	TERMOSTATO 160°	THERMOSTAT 160°	TERMOSTATO 160°	1	REC8M0091470
	FILTRO ACEITE	OIL FILTER	FILTRO OLIO	1	REC35-06003
	FILTRO GASOLINA	FUEL FILTER	FILTRO BENZINA	1	REC35-802893Q01
	IMPULSOR (BRAVO & ENFRIADOR CERRADO)	IMPELLER (BRAVO & CLOSED COOLING SYSTEM)	GIRANTE (BRAVO E SISTEMA RAFFREDDAMENTO CHIUSO)	1	REC47-59362Q01
	CORREA BOMBA DE AGUA (BRAVO)	WATER PUMP BLET (BRAVO)	CINGHIA POMPA DELL'ACQUA (BRAVO)	1	REC57-13457Q
	CORREA DIRECCION HYDRAULICA	HYDRAULIC DIRECTION BELT	CINGHIA STERZO IDRAULICO	1	REC57-34359
	CORREA ALTERNADOR (44")	ALTERNATOR BELT (44")	CINGHIA ALTERNATORE (44")	1	REC3858462
	CORREA ALTERNADOR (46")	ALTERNATOR BELT (46")	CINGHIA ALTERNATORE (46")	1	REC829207
ACEITE MOTOR	OIL	OLIO MOTORE	2	RM92-8M0086224U3	
5.0L & 5.0L EFI (1998-01) (0L015751 - 0M599999)	BUJIA	SPARK PLUG	CANDELE	8	NGKBPR6EFS
	TERMOSTATO 140°	THERMOSTAT 140°	TERMOSTATO 140°	1	REC8M0089715
	TERMOSTATO 160°	THERMOSTAT 160°	TERMOSTATO 160°	1	REC8M0091470
	TERMOSTATO (ENFRIADOR CERRADO)	THERMOSTAT 170° (CLOSED COOLING)	TERMOSTATO 170° (RAFFREDDAMENTO CHIUSO)	1	REC99155T2
	FILTRO ACEITE	OIL FILTER	FILTRO OLIO	1	REC35-06003
	FILTRO GASOLINA	FUEL FILTER	FILTRO BENZINA	1	REC35-802893Q01
	IMPULSOR (BRAVO)	IMPELLER (BRAVO)	GIRANTE (BRAVO)	1	REC47-59362Q01
	ACEITE MOTOR	OIL	OLIO MOTORE	2	RM92-8M0086224U3
	CORREAS	BELT	CINGHIE		
	5.0L CARB. AL- PHA/ BRAVO (0M600000+)	BUJIA	SPARK PLUG	CANDELE	8
TERMOSTATO 140°		THERMOSTAT 140°	TERMOSTATO 140°	1	REC8M0089715
TERMOSTATO 160°		THERMOSTAT 160°	TERMOSTATO 160°	1	REC8M0091470
FILTRO ACEITE		OIL FILTER	FILTRO OLIO	1	REC35-06003
FILTRO GASOLINA		FUEL FILTER	FILTRO BENZINA	1	REC35-802893Q
IMPULSOR (BRAVO)		IMPELLER (BRAVO)	GIRANTE (BRAVO)	1	REC47-59362Q01
CORREA (ALPHA DIRECCIÓN ASITIDA)		BELT (ALPHA POWER STEERING)	CINGHIA (ALPHA SERVOSTERZO)	1	REC57-865615Q04
CORREA (ALPHA SIN DIRECCIÓN ASISTIDA)		BELT (ALPHA NON POWER STERING)	CINGHIA (ALPHA NO SERVOSTERZO)	1	REC57-865615Q09
CORREA (BRAVO DIRECCIÓN ASISTIDA)		BELT (BRAVO POWER STEERING)	CINGHIA (BRAVO SERVOSTERZO)	1	REC57-865615Q03
CORREA (BRAVO SIN DIRECCIÓN ASISTIDA)		BELT (BRAVO NON POWER STEERING)	CINGHIA (BRAVO NO SERVOSTERZO)	1	REC57-865615Q08
ACEITE MOTOR	OIL	OLIO MOTORE	2	RM92-8M0086224U3	
5.0L MPI ALPHA/ BRAVO & EC (0M300000+)	BUJIA	SPARK PLUG	CANDELE	8	NGKITR4A15
	TERMOSTATO 140°	THERMOSTAT 140°	TERMOSTATO 140°	1	REC8M0089715
	TERMOSTATO 160°	THERMOSTAT 160°	TERMOSTATO 160°	1	REC8M0091470
	TERMOSTATO (DRENAJE FÁLCIL 160°)	THERMOSTAT (EASY DRAIN 160°)	TERMOSTATO (SCARICO FACILE 160°)	1	REC99155T2
	TERMOSTATO (DRENAJE FÁCIL 170°)	THERMOSTAT (EASY DRAIN 170°)	TERMOSTATO (SCARICO FACILE 170°)	1	REC864493
	FILTRO ACEITE	OIL FILTER	FILTRO OLIO	1	REC35-06003
	FILTRO GASOLINA	FUEL FILTER	FILTRO BENZINA	1	REC35-802893Q
	FILTRO GASOLINA (MÓDULO GAS.)	FUEL FILTER (FUEL MODULE)	FILTRO BENZINA (MOD. BENZINA)	1	REC35-866171A01
	FILTRO GASOLINA (MÓDULO GAS.)	FUEL FILTER (FUEL MODULE)	FILTRO BENZINA (MOD.BENZINA)	1	REC35-892665
	IMPULSOR (BRAVO)	IMPELLER (BRAVO)	GIRANTE (BRAVO)	1	REC47-862232A2
ACEITE MOTOR	OIL	OLIO MOTORE	2	RM92-8M0086227U3	
CORREAS	BELT	CINGHIE			

Modelo Model Modello	DESCRIPCIÓN	DESCRIPTION	DESCRIZIONE	Unds. Units Unità	Ref.
<b>5.7L CARB. ALPHA/ BRAVO &amp; LX/ EFI (1998+) (0B525982 +)</b>	BUJIA (-0K999999)	SPARK PLUG (-0K999999)	CANDELE (-0K999999)	8	NGKBR6FS
	BUJIA (0L010037+)	SPARK PLUG (0K010037+)	CANDELE (0K010037+)	8	NGKBPR6EFS
	TERMOSTATO 140°	THERMOSTAT 140°	TERMOSTATO 140°	1	REC8M0089715
	TERMOSTATO 160°	THERMOSTAT 160°	TERMOSTATO 160°	1	REC8M0091470
	TERMOSTATO (ENFRIADOR CERRADO)	THERMOSTAT (CLOSED COOLING)	TERMOSTATO (RAFFREDDAMENTO CHIUSO)	1	REC99155T2
	FILTRO ACEITE	OIL FILTER	FILTRO OLIO	1	REC35-06003
	FILTRO GASOLINA	FUEL FILTER	FILTRO BENZINA	1	REC35-802893Q
	IMPELLER (BRAVO)	IMPELLER (BRAVO)	GIRANTE (BRAVO)	1	REC47-59362Q01
	ACEITE MOTOR	OIL	OLIO MOTORE	2	RM92-8M0086224U3
	CORREAS	BELT	CINGHIE		
<b>350 MAG &amp; 350 MAG EFI (GEN+) (1986+) (0A635178 - 0K999999)</b>	BUJIA	SPARK PLUG	CANDELE	8	NGKBR6FS
	BUJIA (EFI)	SPARK PLUG (EFI)	CANDELE (EFI)	8	NGKBPR6EFS
	FILTRO GASOLINA	FUEL FILTER	FILTRO BENZINA	1	REC35-802893Q
	FILTRO GASOLINA VST (EFI)	FUEL FILTER VST (EFI)	FILTRO BENZINA VST (EFI)	1	REC65L-13915-00
	FILTRO ACEITE	OIL FILTER	FILTRO OLIO	1	REC35-06003
	TERMOSTATO 140°	THERMOSTAT 140°	TERMOSTATO 140°	1	REC8M0089715
	TERMOSTATO 160°	THERMOSTAT 160°	TERMOSTATO 160°	1	REC8M0091470
	IMPELLER (BRAVO)	IMPELLER (BRAVO)	GIRANTE (BRAVO)	1	REC47-59362Q01
	ACEITE MOTOR	OIL	OLIO MOTORE	2	RM92-8M0086224U3
	CORREAS	BELT	CINGHIE		
<b>350 MAG/MPI (0F415189+)</b>	BUJIA (-0F601999)	SPARK PLUG (-0F601999)	CANDELE (-0F601999)	8	NGKBR6FS
	BUJIA (0F602000 - 0M299999)	SPARK PLUG (0F602000 - 0M299999)	CANDELE (0F602000 - 0M299999)	8	NGKTR6IX
	BUJIA (0M300000+)	SPARK PLUG (0M300000+)	CANDELE (0M300000+)	8	NGKITR4A15
	FILTRO GASOLINA	FUEL FILTER	FILTRO BENZINA	1	REC35-802893Q
	FILTRO GASOLINA VST (-0M299999)	FUEL FILTER VST (-0M299999)	FILTRO BENZINA VST (-0M299999)	1	REC65L-13915-00
	FILTRO GASOLINA IN-LINE (0M300000 - 0W059999)	FUEL FILTER IN-LINE (0M300000 - 0W059999)	FILTRO BENZINA IN-LINE (0M300000 - 0W059999)	1	REC864572
	FILTRO GASOLINA VST (0W060000+)	FUEL FILTER VST (0W060000+)	FILTRO BENZINA VST (0W060000+)	1	REC35-866171A01
	FILTRO GASOLINA VST (0W060000+)	FUEL FILTER VST (0W060000+)	FILTRO BENZINA VST (0W060000+)	1	REC35-892665
	FILTRO ACEITE	OIL FILTER	FILTRO OLIO	1	REC35-06003
	IMPULSOR (BRAVO) (-0M299999)	IMPELLER (BRAVO) (-0M299999)	GIRANTE (BRAVO) (-0M299999)	1	REC47-59362Q01
	IMPULSOR (BRAVO) (0M300000+)	IMPELLER (BRAVO) (0M300000+)	GIRANTE (BRAVO) (0M300000+)	1	REC47-862232A2
	TERMOSTATO 140°	THERMOSTAT 140°	TERMOSTATO 140°	1	REC8M0089715
	TERMOSTATO 160°	THERMOSTAT 160°	TERMOSTATO 160°	1	REC8M0091470
	TERMOSTATO (FÁCIL DRENAJE & ENFRIADOR CERRADO)	THERMOSTAT (EASY DRAIN & CLOSED COOLING)	TERMOSTATO (SCARICO FACILE E RAFFREDDAMENTO CHIUSO)	1	REC99155T2
	ACEITE MOTOR	OIL	OLIO MOTORE	2	RM92-8M0086227U3
CORREAS	BELT	CINGHIE			
<b>6.2L MPI &amp; 377 MAG MPI (0L302200+)</b>	BUJIA (0L302200 - 0M299999)	SPARK PLUG (0L302200 - 0M299999)	CANDELE (0L302200 - 0M299999)	8	NGKTR6IX
	BUJIA (0M310000+)	SPARK PLUG (0M310000+)	CANDELE (0M310000+)	8	NGKITR4A15
	BUJIA (0M300000+)	SPARK PLUG (0M300000+)	CANDELE (0M300000+)	8	NGKITR4A15
	FILTRO GASOLINA	FUEL FILTER	FILTRO BENZINA	1	REC35-802893Q
	FILTRO GASOLINA IN-LINE (0M311053+)	FUEL FILTER (0M311053+)	FILTRO BENZINA IN-LINE (0M311053+)	1	REC864572
	FILTRO GASOLINA VST (0M398395+)	FUEL FILTER VST (0M398395+)	FILTRO BENZINA VST (0M398395+)	1	REC35-866171A01
	FILTRO GASOLINA VST (0M398395+)	FUEL FILTER VST (0M398395+)	FILTRO BENZINA VST (0M398395+)	1	REC35-892665
	FILTRO ACEITE	OIL FILTER	FILTRO OLIO	1	REC35-06003
	FILTRO ACEITE TRANSMISIÓN HURT/ZEUS	OIL FILTER TRANSMISSION HURT/ZEUS	FILTRO OLIO TRASMISSIONE HURT/ZEUS	1	REC016940
	IMPULSOR (0L302200 - 0M299999)	IMPELLER (0L302200 - 0M299999)	GIRANTE (0L302200 - 0M299999)	1	REC47-59362Q01
	IMPULSOR (0M310000+)	IMPELLER (0M310000+)	GIRANTE (0M310000+)	1	REC47-862232A2
	TERMOSTATO 140°	THERMOSTAT 140°	TERMOSTATO 140°	1	REC8M0089715
	TERMOSTATO 160°	THERMOSTAT 160°	TERMOSTATO 160°	1	REC8M0091470
	TERMOSTATO (DRENAJE FÁCIL & ENFRIADOR CERRADO (-0M316999))	THERMOSTAT (EASY DRAIN & CLOSED COOLING (-0M316999))	TERMOSTATO (SCARICO FACILE & RAFFREDDAMENTO CHIUSO) (-0M316999)	1	REC99155T2
	TERMOSTATO (DRENAJE FÁCIL & ENFRIADOR CERRADO) (0M317000+)	THERMOSTAT (EASY DRAIN & CLOSED COOLING (0M317000+))	TERMOSTATO (SCARICO FACILE & RAFFREDDAMENTO CHIUSO) (0M317000+)	1	REC864493
ACEITE MOTOR	OIL	OLIO MOTORE	2	RM92-8M0086227U3	
CORREAS	BELT	CINGHIE			
<b>7.4L, LX / 454 MAG MPI (1988+) (GEN V&amp;VI) (0M771113 - 0M024330)</b>	BUJIA (0K999999-)	SPARK PLUG (0K999999-)	CANDELE (0K999999-)	8	NGKBR6FS
	BUJIA (0L010003 - 0M024330)	SPARK PLUG (0L010003 - 0M024330)	CANDELE (0L010003 - 0M024330)	8	NGKBPR6EFS
	BUJIA (MPI HORIZON)	SPARK PLUG (MPI HORIZON)	CANDELE (MPI HORIZON)	8	NGKBR6FVX
	FILTRO GASOLINA	FUEL FILTER	FILTRO BENZINA	1	REC35-802893Q
	FILTRO GASOLINA VST (0F602010+)	FUEL FILTER VST (0F602010+)	FILTRO BENZINA VST (0F602010+)	1	REC65L-13915-00
	FILTRO ACEITE	FUEL FILTER	FILTRO BENZINA	1	REC35-06003
	FILTRO ACEITE TRANSMISION HURT/ZEUS	OIL FILTER TRANSMISSION HURT/ZEUS	FILTRO OLIO TRASMISSIONE HURT/ZEUS	1	REC016940
	IMPELLER	IMPELLER	GIRANTE	1	REC47-59362Q01
	TERMOSTATO 140°	THERMOSTAT 140°	TERMOSTATO 140°	1	REC8M0089715
	TERMOSTATO 160°	THERMOSTAT 160°	TERMOSTATO 160°	1	REC8M0091470
	TERMOSTATO (DRENAJE FÁCIL & ENFRIADOR CERRADO)	THERMOSTAT (EASY DRAIN & CLOSED COOLING)	TERMOSTATO (SCARICO FACILE & RAFFREDDAMENTO CHIUSO)	1	REC99155T2
	ACEITE MOTOR	OIL	OLIO MOTORE	2	RM92-8M0086224U3
	CORREAS	BELT	CINGHIE		



Modelo Model Modello	DESCRIPCIÓN	DESCRIPTION	DESCRIZIONE	Unds. Units Unità	Ref.
8.1L (0M0206000+)	BUJIA (-2006)	SPARK PLUG (-2006)	CANDELE (-2006)	8	NGKTR55IX
	BUJIA (2007+)	SPARK PLUG (2007+)	CANDELE (2007+)	8	NGKIZFR7M
	FILTRO GASOLINA	FUEL FILTER	FILTRO BENZINA	1	REC35-802893Q
	FILTRO GASOLINA VST	FUEL FILTER VST	FILTRO BENZINA VST	1	REC35-866171A01
	FILTRO GASOLINA VST	FUEL FILTER VST	FILTRO BENZINA VST	1	REC35-892665
	FILTRO ACEITE	OIL FILTER	FILTRO OLIO	1	REC35-06003
	FILTRO ACEITE TRANSMISION	OIL FILTER TRANSMISSION	FILTRO OLIO TRASMISSIONE	1	REC016940
	HURT/ZEUS	HURT/ZEUS	HURT/ZEUS	1	REC47-862232A2
	IMPULSOR	IMPELLER	GIRANTE	1	REC47-862232A2
	ACEITE MOTOR	OIL	OLIO MOTORE	3	RM92-8M0086227U3
	CORREAS	BELT			
8.2L (1A350802 - 2A041665)	BUJIA	SPARK PLUG	CANDELE	8	NGKBPR6ES
	FILTRO GASOLINA	FUEL FILTER	FILTRO BENZINA	1	REC35-802893Q
	FILTRO GASOLINA VST	FUEL FILTER VST	FILTRO BENZINA VST	1	REC35-866171A01
	FILTRO GASOLINA VST	FUEL FILTER VST	FILTRO BENZINA VST	1	REC35-892665
	FILTRO ACEITE	OIL FILTER	FILTRO OLIO	1	REC35-06003
	FILTRO ACEITE TRANSMISION	OIL FILTER TRANSMISSION	FILTRO OLIO TRASMISSIONE	1	REC016940
	HURT/ZEUS	HURT/ZEUS	HURT/ZEUS	1	REC47-862232A2
	IMPULSOR	IMPELLER	GIRANTE	1	REC47-862232A2
	ACEITE MOTOR	OIL	OLIO MOTORE	3	RM92-8M0086227U3
		CORREAS	BELT		

**MATERIALES GENÉRICOS PARA REVISIÓN  
GENERIC MATERIALS FOR REVISION  
MATERIALI GENERICI REVIEW**

DESCRIPCIÓN	DESCRIPTION	DESCRIZIONE	REF
PINTURA NEGRA MERCURISER EN SPRAY	BLACK PAINT MERCURISER SPRAY	PITTURA NERA MERCURISER. SPRAY	GS90002
SPRAY IMPRIMACION PARA MOTORES	SPRAY PRIMER FOR ENGINES	PRIMER PER MOTORI. SPRAY	GS90012
BARNIZ TRANSPARENTE PROTECTOR PINTURA EN SPRAY	CLEAR VARNISH, SPRAY PAINT PROTECTOR	VERNICE TRASPARENTE, PROTETTORE DI PITTURA. SPRAY	GS90019
PROTECTOR OXIDO MOTOR EN SPRAY	SPRAY ENGINE PROTECTOR FROM RUST	PROTETTORE MOTORE DALL'OSSIDAZIONE. SPRAY	GS90090
PROTECTOR DIELECTRICO EN SPRAY	SPRAY DIELECTRIC PROTECTOR	PROTETTORE DIELETTICO. SPRAY	GS90092
BOTE GRASA MARINA 450 g	MARINE GREASE 450 g	GRASSO MARINO 450 g	LUB11404

**KITS MANTENIMIENTO COLAS  
DRIVES AMINTENANCE KIT  
KIT MANUTENZIONE PIEDE**

**NEW**

MOTOR ENGINE MOTORE	REF				UNID. UNITS UNITA			
ALPHA ONE GEN I	RECKITALPHAI	REC60932A4	FUELLE TRANSON	BELOW	MANICOTTO TRANSON	1		
		REC54-815504320	ABRAZADERA INOX 32-50	HOSE CLAMP 32-50	FASCETTA INOX 32-50	1		
		REC47-89984Q5	KIT BOMBA AGUA	WATER PUMP KITS	KIT POMPA ACQUA	1		
		CMALPHAGEN1KITA	KIT ÁNODOS	ANODES KIT	KIT ANODI	1		
		REC12-191833	JUNTA	GASKET	GUARNIZIONE	2		
		REC26-455771	RETÉN	SEAL	PARAOLIO	1		
		REC18654A1	FUELLE ESCAPE	EXHAUST BELOW	MANICOTTO SCARICO	1		
		REC27-94996Q2	KIT DE JUNTAS	GASKET KIT	KIT GUARNIZIONE	1		
		ALPHA ONE GEN II	RECKITGENEII	REC816431A1	FUELLE TRANSON	BELOW	MANICOTTO TRANSON	1
				REC54-815504320	ABRAZADERA INOX 32-50	HOSE CLAMP 32-50	FASCETTA INOX 32-50	1
REC12-191833	JUNTA			GASKET	GUARNIZIONE	2		
REC26-455771	RETÉN			SEAL	PARAOLIO	1		
CMALPHAKITA	KIT ÁNODOS			ANODES KIT	KIT ANODI	1		
REC47-43026Q06	KIT BOMBA AGUA			WATER PUMP KITS	KIT POMPA ACQUA	1		
REC53-815949	CIERRE METALICO			E-RING	CHIUSURA METALLICO	2		
REC18654A1	FUELLE ESCAPE			EXHAUST BELOW	MANICOTTO SCARICO	1		
REC27-94996Q2	KIT DE JUNTAS			GASKET KIT	KIT GUARNIZIONE	1		
BRAVO	RECKITBRAVO			REC86840A05	FUELLE TRANSON	BELOW	MANICOTTO TRANSON	1
		REC54-815504320	ABRAZADERA INOX 32-50	HOSE CLAMP 32-50	FASCETTA INOX 32-50	1		
		REC12-191833	JUNTA	GASKET	GUARNIZIONE	2		
		REC16755Q1	KIT DE JUNTAS	GASKET KIT	KIT GUARNIZIONE	1		
		CMBRAVO3KITA	KIT ÁNODOS	ANODES KIT	KIT ANODI	1		
		CM806188A	ÁNODO AL	ANODE AL	ANODO AL	1		
REC18654A1	FUELLE ESCAPE	EXHAUST BELOW	MANICOTTO SCARICO	1				



# GUÍA MANTENIMIENTO TRANSMISIONES GUIDE MAINTENANCE TRANSMISSIONS GUIDA MANUTENZIONE TRASMISSIONI

Modelo Model Modello	DESCRIPCIÓN	DESCRIPTION	DESCRIZIONE	Unds. Units Unità	Ref.
<b>TR/TRS (1977-93) (4794900+)</b>	KIT JUNTAS TRANSOM	TRANSOM GASKET KIT	KIT GUARNIZIONE TRANSOM	1	REC27-54014Q1
	FUELLE TRANSMISION	TRANSMISSION BELLOW	CUFFIA TRASMISSIONE	1	REC60932A4
	TAPON DE NIVEL ACEITE	OIL LEVEL CAP	TAPPO LIVELLO OLIO	1	REC10-79953Q04
	TAPON DRENAJE ACEITE	OIL DRAIN CAP	TAPPO SCARICO OLIO	1	REC10-79953Q04
	ANODO TIMON	RUDDER ANODE	ANODO TIMONE	1	CM31640
	ACEITE SINTETICO 80W-90	SYNTHETIC OIL 80W-90	OLIO SINTETICO 80W-90	2	LUB11564U12
	<b>R/ MR/ ALPHA ONE (1983-90) (6216687 - 0F386995)</b>	KIT JUNTAS TRANSOM	TRANSOM GASKET KIT	KIT GUARNIZIONE TRANSOM	1
RODAMIENTO TRANSOM		TRANSOM BEARING	CUSCINETTO TRANSOM	1	REC30-879194A01
FUELLE TRANSMISION		TRANSMISSION BELLOW	CUFFIA TRASMISSIONE	1	REC60932A4
FUELLE ESCAPE		EXHAUST BELLOW	CUFFIA DI SCARICO	1	REC18654A1
FUELLE ESCAPE TUBO (454 MAG)		EXHAUST BELLOW TUBE (454 MAG)	CUFFIA DI SCARICO TUBO (454 MAG)	1	REC78458A1
FUELLE CABLE CAMBIO		SHIFT WIRE BELLOW	CUFFIA CAVO CAMBIO	1	REC74639Q02
TAPON DE NIVEL ACEITE		OIL LEVEL CAP	TAPPO LIVELLO OLIO	1	REC10-79953Q04
TAPON DRENAJE ACEITE		OIL DRAIN CAP	TAPPO SCARICO OLIO	1	REC22-67892A05
ANODO TIMON (2-3/8")		RUDDER ANODE (2-3/8")	ANODO TIMONE (2-3/8")	1	CM31640
ANODO TIMON (4")		RUDDER ANODE (4")	ANODO TIMONE (4")	1	CM34127
ANODO BOLA TRANSOM		BALL ANODE TRANSOM	ANODO BOLLA TRANSOM	1	REC55989Q9
ANODO TRANSOM (MERCAT)		TRANSOM ANODE (MERCAT)	ANODO TRANSOM (MERCAT)	1	CM821631
ANODO TRAN (MERCAT) ANTIGUO		TRAN ANODE (MERCAT) OLD	ANODO TRAN (MERCAT) VECCHIO	1	CM43994
KIT ANODOS		ANODE KIT	KIT ANODI	1	CMALPHAGEN1KITA CMALPHAGEN1KITM TENKITALPHAONE/1
TUBO AGUA 5/8" TRANSOM		WATER TUBE 5/8" TRANSOM	TUBO ACQUA 5/8" TRANSOM	1	REC32-32461
TUBO AGUA 3/4" TRANSOM		WATER TUBE 3/4" TRANSOM	TUBO ACQUA 3/4" TRANSOM	1	REC32-4172533
IMPULSOR		IMPELLER	GIRANTE	1	REC47-89984T4
KIT BOMBA DE AGUA		WATER PUMP KIT	KIT POMPA ACQUA	1	REC47-89984Q5
KIT CABLE CAMBIO		SHIFT WIRE KIT	KIT CAVO CAMBIO	1	REC865436A03
KIT SENSORES TRIM		SENSOR TRIM KIT	KIT SENSORI TRIM	1	REC805320A03
ACEITE SINTETICO 80W-90	SYNTHETIC OIL 80W-90	OLIO SINTETICO 80W-90	2	LUB11564U12	
<b>APLHA ONE (GENII) (1991+) (0D469259+)</b>	KIT JUNTAS TRANSOM	TRANSOM GASKET KIT	KIT GUARNIZIONE TRANSOM	1	REC27-94996Q2
	RODAMIENTO TRANSOM	TRANSOM BEARING	CUSCINETTO TRANSOM	1	REC30-879194A01
	FUELLE TRANSMISION	TRANSMISSION BELLOW	CUFFIA TRASMISSIONE	1	REC816431A1
	FUELLE ESCAPE	EXHAUST BELLOW	CUFFIA DI SCARICO	1	REC18654A1
	FUELLE CABLE CAMBIO	SHIFT WIRE BELLOW	CUFFIA CAVO CAMBIO	1	REC74639Q02
	TAPON DE NIVEL ACEITE	OIL LEVEL CAP	TAPPO LIVELLO OLIO	1	REC10-79953Q04
	TAPON DRENAJE ACEITE	OIL DRAIN CAP	TAPPO SCARICO OLIO	1	REC22-67892A05
	ANODO PLACA	PLATE ANODE	ANODO PIASTRA	1	CM821629
	ANODO TRANSOM (MERCAT)	TRANSOM ANODE (MERCAT)	ANODO TRANSOM (MERCAT)	1	CM821631
	ANODO TIMON (PLANO)	RUDDER ANODE (FLAT)	ANODO TIMONE (PLANO)	1	CM762145
	ANODO TIMON (ALETA)	RUDDER ANODE (FLAP)	ANODO TIMONE (FLAP)	1	CM46399
	ANODO HELICE (CARRIER)	PROPELLER ANODE (CARRIER)	ANODO ELICA (CARRIER)	1	CM806105
	ANODO BRAZO TRIM	TRIM ARM ANODE	ANODO BRACCIO TRIM	2	CM806189
	KIT ANODOS	ANODE KIT	KIT ANODI	1	CMALPHAKITA CMALPHAKITM TENKITALPHAONE/2
	TUBO AGUA TRANSOM	WATER TUBE TRANSOM	TUBO ACQUA TRANSOM	1	REC32-4172533
	IMPULSOR	IMPELLER	GIRANTE	1	REC47-43026Q02
	KIT BOMBA DE AGUA	WATER PUMP KIT	KIT POMPA ACQUA	1	REC817275Q05
KIT CABLE CAMBIO	SHIFT WIRE KIT	KIT CAVO CAMBIO	1	REC865436A03	
KIT SENSORES TRIM	SENSOR TRIM KIT	KIT SENSORI TRIM	1	REC805320A03	
ACEITE SINTETICO 80W-90	SYNTHETIC OIL 80W-90	OLIO SINTETICO 80W-90	2	LUB11564U12	
<b>BRAVO I / II &amp; III</b>	KIT JUNTAS TRANSOM	TRANSOM GASKET KIT	KIT GUARNIZIONE TRANSOM	1	REC16755Q1
	RODAMIENTO TRANSOM	TRANSOM BEARING	CUSCINETTO TRANSOM	1	REC30-879194A01
	FUELLE TRANSMISION	TRANSMISSION BELLOW	CUFFIA TRASMISSIONE	1	REC86840A05
	FUELLE ESCAPE	EXHAUST BELLOW	CUFFIA DI SCARICO	1	REC18654A1
	FUELLE ESCAPE TUBO	EXHAUST BELLOW	CUFFIA DI SCARICO	1	REC78458A1
	FUELLE CABLE CAMBIO	SHIFT WIRE BELLOW	CUFFIA CAVO CAMBIO	1	REC74639Q02
	TAPON DE NIVEL ACEITE	OIL LEVEL CAP	TAPPO LIVELLO OLIO	1	REC22-67892A05
	TAPON DRENAJE ACEITE	OIL DRAIN CAP	TAPPO SCARICO OLIO	1	REC22-67892A05
	ANODO PLACA	PLATE ANODE	ANODO PIASTRA	1	CM821630
	ANODO TRANSOM (MERCAT)	TRANSOM ANODE (MERCAT)	ANODO TRANSOM (MERCAT)	1	CM43994
	ANODO TIMON (PLANO CON ROSCA)	RUDDER ANODE (FLAT WITH THREAD)	ANODO TIMONE (PLANO CON FILO)	1	CM76214Q5
	ANODO TIMON (PLANO SIN ROSCA)	RUDDER ANODE (FLAT WITHOUT THREAD)	ANODO TIMONE (PLANO SENZA FILO)	1	CM762144
	ANODO HELICE (CARRIER)	PROPELLER ANODE (CARRIER)	ANODO ELICA (CARRIER)	1	CM806188
	ANODO EJE HELICE (BRAVO III 2004+)	SHAFT PROPELLER ANODE (BRAVO III 2004+)	ANODO ASSE ELICA (BRAVO III 2004+)	1	CM865182CZ
	ANODO BRAZO TRIM	TRIM ARM ANODE	ANODO BRACCIO TRIM	2	CM806190
	ANODO BOLA TRANSOM	BALL ANODE TRANSOM	ANODO BOLLA TRANSOM	1	REC55989Q9
	KIT ANODOS BRAVO I	ANODE KIT BRAVO I	KIT ANODI BRAVO I	1	CMBRAVO1KITA CMBRAVO1KITM TENKITBRAVOI
	KIT ANODOS BRAVO II	ANODE KIT BRAVO II	KIT ANODI BRAVO II	1	CMBRAVO2Y3KITA CMBRAVO2Y3KITM TENKITBRAVOII-III
	KIT ANODOS BRAVO III	ANODE KIT BRAVO III	KIT ANODI BRAVO III	1	CMBRAVO3KITA CMBRAVO3KITM TENKITBRAVOIII-04
	TUBO AGUA TRANSOM (BRAVO I)	WATER TUBE TRANSOM (BRAVO I)	TUBO ACQUA TRANSOM (DESIGN 1)	1	REC32-43437
KIT CABLE CAMBIO	SHIFT WIRE KIT	KIT CAVO CAMBIO	1	REC815471T1	
KIT SENSORES TRIM	SENSOR TRIM KIT	KIT SENSORI TRIM	1	REC805320A03	
ACEITE SINTETICO 80W-90	SYNTHETIC OIL 80W-90	OLIO SINTETICO 80W-90	3	LUB11564U12	

# HÉLICES ALUMINO E INOXIDABLES DE 3 Y 4 PALAS 3 & 4 BLADE ALUMINUM & STAINLESS STEEL PROPELLERS ELICHE ALLUMINIO E INOX DA 3 E 4 PALE

SISTEMA CODIGO REFERENCIAS  
PART NO. CODING SYSTEM  
SISTEMA DI CODICE

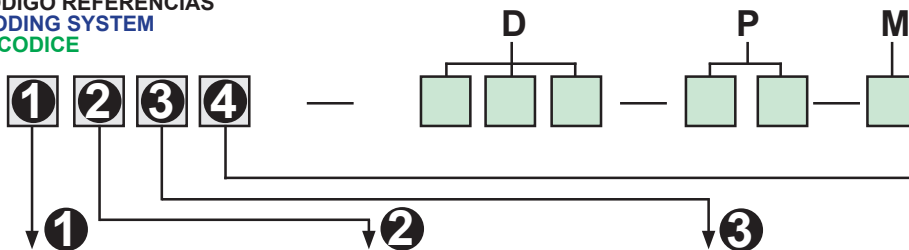

<ol style="list-style-type: none"> <li>1. Mercury, Mariner</li> <li>2. Johnson, Evinrude</li> <li>3. Yamaha</li> <li>4. Suzuki</li> <li>5. Tohatsu</li> <li>6.</li> <li>7.</li> <li>8. Volvo Penta</li> <li>9. Rubex System</li> </ol>	<ol style="list-style-type: none"> <li>0.5,6,8 and 9.8 HP Grupo /Group / Gruppo</li> <li>1. A Grupo /Group / Gruppo</li> <li>2. B Grupo /Group / Gruppo</li> <li>3. C Grupo /Group / Gruppo</li> <li>4. D Grupo /Group / Gruppo</li> <li>5. E Grupo /Group / Gruppo</li> <li>6. F Grupo /Group / Gruppo</li> <li>7. VP (Cubo std./Std. Hub / mozzo std.)</li> <li>8. VP (Cubo largo /Long Hub / mozzo lungo)</li> </ol>	<ol style="list-style-type: none"> <li>1. Aluminio /Aluminum / Alluminio</li> <li>2. Saturn Acero inox. /S.S. / Acciaio inox.</li> <li>3. New Saturn Acero inox. /S.S. / Acciaio inox.</li> <li>4. Titan Acero inox. /S.S. / Acciaio inox.</li> <li>5. HR Titan Acero inox. /S.S. / Acciaio inox.</li> </ol>	<ol style="list-style-type: none"> <li>1. 3R Rubber Hub</li> <li>2. 3L Rubber Hub</li> <li>3. 4R Rubber Hub</li> <li>4. 4L Rubber Hub</li> </ol>
--	---	--	--

Ejemplo / Note / Esempio

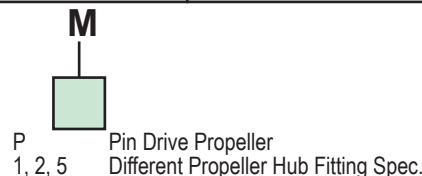
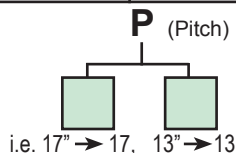
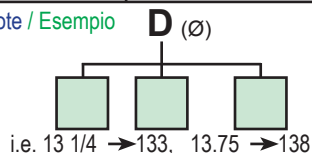

## SOLAS

### AMITA 3

- Hélices de aluminio de 3 palas con núcleo de goma de gran resistencia.
- 3 blade aluminum propeller with heavy duty rubber hub.
- Eliche in alluminio a 3 pale con mozzi in gomma ad alta resistenza.



## SOLAS

### AMITA 4

- Hélices de aluminio de 4 palas con núcleo de goma de gran resistencia.
- Van muy suaves a poca velocidad y hace el barco muy manejable con la mar picada.
- 4 Blade aluminum propeller with heavy duty rubber hub.
- Smoother low speed makes the offshore boating activity much easier.
- Eliche in alluminio a 4 pale con mozzo in gomma ad alta resistenza.
- Ideale per basse velocità, rendono l'imbarcazione molto maneggevole anche con mare mosso.



## SOLAS

### NEW SATURN PROP

- Hélices de acero inoxidable de 3 palas.
- Ofrece buena aceleración y rendimiento.
- Tamaño más pequeño que ofrece un diámetro extragrande.
- Three blade stainless steel propeller.
- Offers good acceleration & all-round performance.
- Smaller pitch sizes offered in extra large diameter with increased blade area.
- Eliche in acciaio inox a 3 pale.
- Consentono buone accelerazioni.
- Con un'area più ampia nelle pale.



## SOLAS

### HR TITAN 3 PROP

- Hélice de acero inoxidable de 3 palas.
- Alto rendimiento para cascos de alta velocidad.
- La inclinación de la hoja proporciona un excelente elevación de proa y aceleración.
- El diseño de copa grande aumenta la mordida y reduce el deslizamiento.
- Three blade stainless steel propeller.
- Performance prop for high speed planning hulls.
- High rake blade design provides excellent bow lift and acceleration.
- Heavy cup design increases bite and reduces slip.
- Eliche di acciaio inox a 3 pale.
- Alte prestazioni per scafi ad alta velocità.
- Il passo della pala fornisce un'eccellente elevazione e accelerazione.
- Il disegno della coppa aumenta le prestazioni e riduce lo slittamento.



## SOLAS

### LEXOR

- Hélices de acero inox. de 3 palas anchas.
- Gran diámetro.
- Mejor aceleración y ahorro de combustible.
- 3 blade stainless steel propeller.
- Large diameter and blade area for big boat loads.
- Great high speed performance without sacrificing mid-range speeds.
- Excellent fuel economy for offshore boats.
- Eliche in acciaio inox da 3 pale larghe.
- Migliore accelerazione.



HP	R.O. OEM	B	D	P	R	TIPO TYPE	ALUMINIO ALUMINIUM ALLUMINIO		INOX STAINLESS STEEL ACCIAIO INOSSIDABILE			
							AMITA 3	AMITA 4	NEW SATURN	HR TITAN 3	LEXOR	
ALPHA ONE	48-78114A45	3	16	13	R	BLACK MAX	SOL1511-160-13		SOL1531-156-13			
	48-78116A4	3	15 1/2	15	R	BLACK MAX	SOL1511-150-15	SOL1513-148-15	SOL1531-145-15			
	48-832828A45	3	15	17	R	BLACK MAX	SOL1511-148-17	SOL1513-145-17	SOL1531-143-17			
	48-832830A45	3	14 1/2	19	R	BLACK MAX	SOL1511-145-19	SOL1513-143-19	SOL1531-140-19			
	48-832832A45	3	14 1/2	21	R	BLACK MAX	SOL1511-143-21	SOL1513-140-21	SOL1531-140-21			
	48-832834A45	3	14	23	R	BLACK MAX	SOL1511-142-23	SOL1513-140-23	SOL1531-140-23			
	48-78126A45	3	13 3/8	25	R	BLACK MAX			SOL1531-140-25			
	48-831850A45	4	15	16	R	ALPHA 4		SOL1513-145-17				
	48-834851A45	4	15	16	L	ALPHA 4		SOL1514-145-17				
	48-834852A45	4	14 1/2	18	R	ALPHA 4		SOL1513-143-19				
	48-834853A45	4	14 1/2	18	L	ALPHA 4		SOL1514-143-19				
	48-834854A45	4	14	20	R	ALPHA 4		SOL1513-140-21				
	48-834855A45	4	14	20	L	ALPHA 4		SOL1514-140-21				
	48-16312A46	3	14 1/2	15	R	VENGEANCE			SOL1531-145-15			
	48-16314A46	3	14 1/2	17	R	VENGEANCE			SOL1531-143-17	SOL1551-148-16		
	48-16315A46	3	14 1/2	17	L	VENGEANCE			SOL1532-143-17	SOL1552-148-16		
	48-16316A46	3	14	19	R	VENGEANCE			SOL1531-140-19	SOL1551-148-18		
	48-16317A46	3	14	19	L	VENGEANCE			SOL1532-140-19	SOL1552-148-18		
	48-16318A46	3	13 3/4	21	R	VENGEANCE			SOL1531-140-21	SOL1551-148-20		
	48-16319A46	3	13 3/4	21	L	VENGEANCE			SOL1532-140-21	SOL1552-148-20		
48-16320A46	3	13 1/2	23	R	VENGEANCE			SOL1531-140-23	SOL1551-143-22			
48-16321A46	3	13 1/2	23	L	VENGEANCE			SOL1532-140-23	SOL1552-143-22			
BRAVO ONE	48-16322A46	3	13 3/8	25	R	VENGEANCE			SOL1531-140-25	SOL1551-140-24		
	48-16544A46	3	14	19	R	LASER II				SOL1551-148-19		
	48-16543A46	3	14	19	L	LASER II				SOL1552-148-19		
	48-16546A46	3	13 7/8	21	R	LASER II				SOL1551-145-21		
	48-16545A46	3	13 7/8	21	L	LASER II				SOL1552-145-21		
	48-16548A46	3	13 3/4	23	R	LASER II				SOL1551-143-22		
	48-16547A46	3	13 3/4	23	L	LASER II				SOL1552-143-22		
	48-16550A46	3	13 3/4	25	R	LASER II				SOL1551-140-24		
	48-16549A46	3	13 3/4	25	L	LASER II				SOL1552-140-24		
	48-826072A46	3	16	13	R	MIRAGE PLUS	SOL1511-160-13					
	48-19838A46	3	15 3/4	15	R	MIRAGE PLUS	SOL1511-158-15					
	48-19841A46	3	15 3/4	15	L	MIRAGE PLUS	SOL1512-158-15					
	48-18278A46	3	15 1/2	17	R	MIRAGE PLUS	SOL1511-155-17				SOL1571-155-17	
	48-90159A46	3	15 1/2	17	L	MIRAGE PLUS	SOL1512-155-17				SOL1572-155-17	
	48-13700A46	3	15 1/4	19	R	MIRAGE PLUS	SOL1511-153-19				SOL1571-153-19	
	48-13701A46	3	15 1/4	19	L	MIRAGE PLUS	SOL1512-153-19				SOL1572-153-19	
	48-13702A46	3	13 3/4	21	R	MIRAGE PLUS	SOL1511-153-21				SOL1571-150-21	
	48-13703A46	3	14 3/4	21	L	MIRAGE PLUS	SOL1512-153-21				SOL1572-150-21	
	48-13704A46	3	14 5/8	23	R	MIRAGE PLUS	SOL1511-153-23				SOL1571-148-23	
	48-13705A46	3	14 5/8	23	L	MIRAGE PLUS					SOL1571-148-23	
48-13706A46	3	14 1/2	25	R	MIRAGE PLUS					SOL1571-145-25		
48-13707A46	3	14 1/2	25	L	MIRAGE PLUS					SOL1572-145-25		
BRAVO II	48-18610A40	3	19 1/4	15	R	ALUM	SOL1611-193-15			SOL1641-193-15		
	48-18611A40	3	19 1/4	15	L	ALUM	SOL1612-193-15			SOL1642-193-15		
	48-18612A40	3	18 3/4	17	R	ALUM	SOL1611-188-17			SOL1641-188-17		
	48-18613A40	3	18 3/4	17	L	ALUM	SOL1612-188-17			SOL1642-188-17		
	48-18614A40	3	18 1/4	19	R	ALUM	SOL1611-183-19			SOL1641-183-19		
	48-18615A40	3	18 1/4	19	L	ALUM	SOL1612-183-19			SOL1642-183-19		
	4.3L LH, EFI	48-18616A40	3	17 3/4	21	R	ALUM	SOL1611-178-21			SOL1641-178-21	
	5.0L EFI	48-18617A40	3	17 3/4	21	L	ALUM	SOL1612-178-21			SOL1642-178-21	
	350 MAG EMPI	48-18618A40	3	17 1/2	23	R	ALUM				SOL1641-175-23	
	454 MAG MPI	48-18619A40	3	17 1/2	23	L	ALUM				SOL1642-175-23	
	502 MAG MPI	48-18620A40	3	17 1/4	25	R	ALUM				SOL1641-175-23	
	D2.8L	48-18621A40	3	17 1/4	25	L	ALUM				SOL1642-173-25	
	D-TRONIC	48-18610A6	3	19 1/4	15	R	SS	SOL1611-193-15			SOL1641-193-15	
	D3.6L	48-18611A6	3	19 1/4	15	L	SS	SOL1612-193-15			SOL1642-193-15	
	D4.2L	48-18612A6	3	18 3/4	17	R	SS	SOL1611-188-17			SOL1641-188-17	
	D-TRONIC	48-18613A6	3	18 3/4	17	L	SS	SOL1612-188-17			SOL1642-188-17	
	D7.3L	48-18614A6	3	18 1/4	19	R	SS	SOL1611-183-19			SOL1641-183-19	
	D-TRONIC	48-18615A6	3	18 1/4	19	L	SS	SOL1612-183-19			SOL1642-183-19	
	7.4L MPI	48-18616A6	3	17 3/4	21	R	SS	SOL1611-178-21			SOL1641-178-21	
		48-18617A6	3	17 3/4	21	L	SS	SOL1612-178-21			SOL1642-178-21	
	48-18618A6	3	17 1/2	23	R	SS				SOL1641-175-23		
	48-18619A6	3	17 1/2	23	L	SS				SOL1642-175-23		
	48-18620A6	3	17 1/4	25	R	SS				SOL1641-173-25		
	48-18621A6	3	17 1/4	25	L	SS				SOL1642-173-25		

B= PALAS / Blades / Pale  
D= DIÁMETRO / Diametre / Diametro  
P= PASO / Pich / Passo

R=ROTACIÓN / Rotation / Rotazione  
(R) Derecha / Right / DX  
(L) Izquierda / Left / SX

## BRAVO III

### HELICES DE ACERO INOXIDABLE

Hélices delanteras de 4 palas y hélices traseras de 3 palas. 19 estrías y escape a través de la hélice.

### STAINLESS STEEL PROPELLERS

Front propellers with 4 blades & rear propellers with 3 blades. 19 Tooth Spline and Thru hub exhaust.

### ELICHE IN ACCIAIO INOX

Eliche anteriori da 4 pale e eliche posteriori da 3 pale. 19 denti e scarico all'elica.

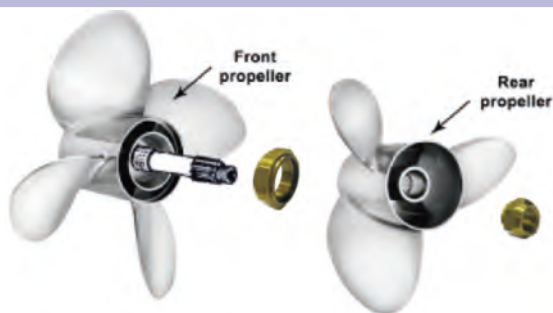

REF	POSICIÓN DELANTERA FRONT POSITION POSIZIONE ANTERIORE	POSICIÓN TRASERA REAR POSITION POSIZIONE POSTERIORE	PALAS BLADES PALE	Ø	PASO PITCH PASSO	ROTACIÓN IZQUIERDA LEFT ROTATION ROTAZIONE SINISTRA	ROTACIÓN DERECHA RIGHT ROTATION ROTAZIONE DESTRA
SOL1654-160-20	✓		4	16"	20	✓	
SOL1651-144-20		✓	3	14 3/8"	20		✓
SOL1654-160-21	✓		4	16"	21	✓	
SOL1651-144-21		✓	3	14 3/8"	21		✓
SOL1654-158-22	✓		4	15 3/4"	22	✓	
SOL1651-143-22		✓	3	14 1/4"	22		✓
SOL1654-158-23	✓		4	15 3/4"	23	✓	
SOL1651-143-23		✓	3	14 1/4"	23		✓
SOL1654-155-24	✓		4	15 1/2"	24	✓	
SOL1651-140-24		✓	3	14"	24		✓
SOL1654-155-25	✓		4	15 1/2"	25	✓	
SOL1651-140-25		✓	3	14"	25		✓
SOL1654-155-26	✓		4	15 1/2"	26	✓	
SOL1651-140-26		✓	3	14"	26		✓
SOL1654-155-27	✓		4	15"	27	✓	
SOL1651-140-27		✓	3	13 3/4"	27		✓
SOL1654-150-28	✓		4	15"	28	✓	
SOL1651-138-28		✓	3	13 3/4"	28		✓

## HÉLICES 3 PALAS ALPHA ONE Y BRAVO ONE 3 BLADE PROPELLERS ALPHA ONE & BRAVO ONE ELICHE DA 3 PALE ALPHA ONE E BRAVO ONE

# RUBEX

Altas prestaciones. Núcleo de goma intercambiable con sistemas flo-torq & Vortex System. Disponible en acero inox y aluminio  
High performance / Rubber Hub interchangeable with flo-torq & Vortex System. Available in stainless Steel & Aluminium Propeller  
Alte prestazioni. Mozzo in gomma intercambiabile con sistema flo-torq & Vortex System. Disponibile in acciaio inos e alluminio.

Ref.	R.O. OEM
SOLRBX-102	

MOTORES / ENGINES / MOTORI  
ALPHA ONE  
BRAVO ONE



### HÉLICE DE ALUMINIO HASTA 400 HP, 15 DIENTES ALUMINUM PROPELLERS, LESS THAN 400 HP, 15 TOOTH SPLINE ELICHE IN ALLUMINIO, FINO A 400 HP, 15 DENTI

REF	PALAS BLADES PALE	Ø	PASO PITCH PASSO	ROTACIÓN ROTATION ROTAZIONE
SOL9511-153-13	3	15,3	13	R
SOL9511-150-15	3	15	15	R
SOL9512-150-15	3	15	15	L
SOL9511-148-17	3	14,8	17	R
SOL9512-148-17	3	14,8	17	L
SOL9511-145-19	3	14,5	19	R
SOL9512-145-19	3	14,5	19	L
SOL9511-143-21	3	14,3	21	R
SOL9512-143-21	3	14,3	21	L
SOL9513-148-15	4	14,75	15	R
SOL9513-145-17	4	14,5	17	R
SOL9513-143-19	4	14,25	19	R
SOL9513-140-21	4	14	21	R

### HELICE DE ACERO INOX. HASTA 400 HP, 15 DIENTES STAINLESS STEEL PROPELLERS, LESS THAN 400 HP, 15 TOOTH SPLINE ELICHE IN ACCIAIO INOX., FINO A 400 HP, 15 DENTI

#### RUBEX L3

REF	PALAS BLADES PALE	Ø	PASO PITCH PASSO	ROTACIÓN ROTATION ROTAZIONE
SOL9571-158-15	3	15 3/4	15	R
SOL9572-158-15	3	15 3/4	15	L
SOL9571-155-17	3	15 1/2	17	R
SOL9572-155-17	3	15 1/2	17	L
SOL9571-153-19	3	15 1/4	19	R
SOL9572-153-19	3	15 1/4	19	L
SOL9571-150-21	3	15	21	R
SOL9572-150-21	3	15	21	L
SOL9571-148-23	3	14 3/4	23	R
SOL9572-148-23	3	14 3/4	23	L
SOL9571-145-25	3	14 1/2	25	R
SOL9572-145-25	3	14 1/2	25	L

#### RUBEX NS3

REF	PALAS BLADES PALE	Ø	PASO PITCH PASSO	ROTACIÓN ROTATION ROTAZIONE
SOL9531-145-15	3	14 1/2	15	R
SOL9532-145-15	3	14 1/2	15	L
SOL9531-143-17	3	14 1/4	17	R
SOL9532-143-17	3	14 1/4	17	L
SOL9531-140-19	3	14	19	R
SOL9532-140-19	3	14	19	L
SOL9531-140-21	3	14	21	R
SOL9532-140-21	3	14	21	L
SOL9531-140-23	3	14	23	R
SOL9532-140-23	3	14	23	L

# TABLA DE APLICACIÓN DE HéLICES SOLAS PROPELLERS SOLAS APPLICATION GUIDE GUIDA APPLICAZIONE ELICHE SOLAS

	AMITA3	AMITA4	BRAVO TWO	SATURN	NEW SATURN	TITAN	HR TITAN3	HR TITAN4	SCORPION	LEXOR	SOLAS SKI	SOLAS PLASTIC	HIGH THRUST	
<b>FUERABORDA / OUTBOARD / FUORIBORDO</b>														
INFLATABLE	✓	✓		✓	✓	✓						✓		
ALUMINIUM	✓			✓	✓	✓								
SKI BOAT	✓	✓				✓	✓							
BASSBOAT	✓							✓	✓					
FLATS BOAT	✓							✓						
BAY BOAT										✓				
WALLEYE BOAT	✓							✓						
OFFSHORE SINGLE	✓	✓				✓	✓	✓		✓				
OFFSHORE DUAL	✓	✓				✓	✓	✓		✓				
SPORT BOAT SINGLE										✓				
SPORT BOAT DUAL								✓		✓				
HEAVY WORK BOAT	✓	✓			✓	✓		✓						
COMMERCIAL	✓			✓										
SAIL DRIVE													✓	
PLEASURE														
RUNABOUT	✓	✓		✓	✓	✓		✓						
DECK BOAT		✓						✓						
PONTOON	✓	✓		✓	✓	✓								
<b>DENTROFUERABORDA / STERNDRIVE / ENTROFUORIBORDO</b>														
SKI BOAT														
SPORT BOAT SINGLE								✓		✓				
SPORT BOAT DUAL								✓		✓				
FAMILY CRUISER	✓	✓				✓	✓	✓		✓				
CRUISER BOAT			✓											
DECK BOAT								✓						
PONTOON								✓		✓				
HOUSEBOAT	✓	✓		✓	✓	✓		✓		✓				
INBOARD SKI BOAT											✓			
<b>CARACTERÍSTICAS / FEATURES / CARATTERISTICHE</b>														
<b>MATERIAL</b> MATERIAL MATERIALE	AL	AL	AL ACERO INOX STAINLESS STEEL ACCIAIO INOX	ACERO INOX STAINLESS STEEL ACCIAIO INOX	ACERO INOX STAINLESS STEEL ACCIAIO INOX	ACERO INOX STAINLESS STEEL ACCIAIO INOX	ACERO INOX STAINLESS STEEL ACCIAIO INOX	ACERO INOX STAINLESS STEEL ACCIAIO INOX	ACERO INOX STAINLESS STEEL ACCIAIO INOX	ACERO INOX STAINLESS STEEL ACCIAIO INOX	ACERO INOX STAINLESS STEEL ACCIAIO INOX	PLÁSTICO PLASTIC PLASTICA	AL	
<b>PALAS</b> BLADES PALE	3	4	3	3	3	3	3	4	3	3	3.4	3	4	
<b>ROTACIÓN</b> ROTATION ROTAZIONE	IZQUIERDA LEFT SINISTRA	IZQUIERDA LEFT SINISTRA	IZQUIERDA LEFT SINISTRA	IZQUIERDA LEFT SINISTRA	IZQUIERDA LEFT SINISTRA	IZQUIERDA LEFT SINISTRA	IZQUIERDA LEFT SINISTRA	IZQUIERDA LEFT SINISTRA	IZQUIERDA LEFT SINISTRA	IZQUIERDA LEFT SINISTRA	IZQUIERDA LEFT SINISTRA	DERECHA RIGHT DESTRA	DERECHA RIGHT DESTRA	DERECHA RIGHT DESTRA
<b>NÚCLEO</b> HUB MOZZO	GOMA RUBBER GOMMA	GOMA RUBBER GOMMA	GOMA RUBBER GOMMA	GOMA RUBBER GOMMA	GOMA RUBBER GOMMA	GOMA RUBBER GOMMA	GOMA RUBBER GOMMA	GOMA RUBBER GOMMA	GOMA RUBBER GOMMA	GOMA RUBBER GOMMA	GOMA RUBBER GOMMA		GOMA RUBBER GOMMA	













Table with columns: REF, R.O./OEM, PAG. Rows include items like REC326649, REC326849, REC3302-804689, etc.

Table with columns: REF, R.O./OEM, PAG. Rows include items like REC3850397, REC3850397, REC3850559, etc.

Table with columns: REF, R.O./OEM, PAG. Rows include items like REC392-6324Q1, REC392-6325Q1, REC392-6325Q1, etc.

























# ÍNDICE

## PARTES DE MOTOR

JUNTA BASE MOTOR FEL-PRO 274

**JUNTAS MOTORES GASOLINA 286**

- CULATA 286
- KIT SUPERIOR 286
- TAPA BALANCINES 287
- ADMISIÓN Y ESCAPE 288
- CÁRTER 288
- KIT INFERIOR 289

**JUNTAS MOTORES DIESEL 290**

- CULATA 290
- KITS SUPERIOR 292
- TAPA BALANCINES 296
- TAPA LATERAL BLOQUE 297
- COLECTOR Y CODOS ESCAPE 297
- JUNTAS PARA TURBOS 298
- TAPA TRASERA CIGÜEÑAL 299
- TAPA DISTRIBUCIÓN 299
- CÁRTER 299
- KITS INFERIOR 300

RETENES DE CIGÜEÑAL 303

**PISTONES 304**

- KITS PISTONES 304
- KITS CAMISAS Y AROS 305
- KITS COJINETES DE BANCADA 307
- KITS COJINETES BIELA 310
- KITS COJINETES ÁRBOL DE LEVAS 312

**VÁLVULAS 313**

- RETENES 313
- VÁLVULAS ADMISIÓN Y ESCAPE 314
- GUÍAS 315
- MUELLES 315
- PRISIONERO DE VÁLVULA 316
- LIFTER 316
- DEPRESOR DE VÁLVULA 316

**COMPONENTES FIJACIÓN 316**

- KIT TORNILLOS CULATA Y TUERCA 316
- TAPÓN ÁRBOL DE LEVAS 316
- TAPONES BLOQUE 316

## SISTEMA DE ESCAPE Y ADMISIÓN

- DESPIECES COLECTORES Y CODOS 317
- COLECTORES ESCAPE GASOLINA 325
- CODOS ESCAPE GASOLINA 326
- EXTENSORES DE ESCAPE 327
- CUERNOS ESCAPE SX 328
- CODOS ESCAPE DIESEL 328
- CODOS ESCAPE INOX 329
- COLECTORES DE ADMISIÓN 330
- GUÍA CODOS ESCAPE 331

## SISTEMA DE REFRIGERACIÓN

ENFRIADOR DE ACEITE 332

**BOMBA CIRCULACIÓN DE BLOQUE 332**

- BOMBAS GASOLINA 332
- JUNTAS DE BOMBAS GASOLINA 333
- BOMBAS DIESEL 333
- KITS REPARACIÓN BOMBA 334
- JUNTAS DE BOMBAS DIESEL 334
- MANGUITOS 334
- GUÍA BOMBA DE CIRCULACIÓN 335

FILTRO DE AGUA SALADA 336

**BOMBA ASPIRACIÓN AGUA MARINA 337**

- TOPE BOMBAS 342
- CONSOLAS PARA BOMBAS 342
- COJINETE BOMBA 342
- TORNILLOS 343
- TAPA DEPÓSITO EXPANSIÓN 343
- KITS RETENES Y JUNTAS 343
- CENTRADORES 344

**PÁG**

- IMPULSORES 344
- GUÍA DE IMPULSORES 347
- KITS REPARACIÓN BOMBA 348
- RETENES BOMBA 350
- RETENES TUBO REFRIGERACIÓN 350
- TAPONES DRENAJE 352

**TERMOSTATOS 353**

- KITS 353
- CUERPO 355
- JUNTAS 355

**INTERCAMBIADOR DE CALOR 356**

- KITS RETENES Y JUNTAS 356

**ENFRIADOR DE AIRE 358**

- KITS RETENES 359

## SISTEMA ALIMENTACIÓN Y FILTRACIÓN

**FILTROS COMBUSTIBLE 300**

- BRACKETS 300
- FILTRO SEPARADOR DE AGUA 300
- RÁCORES 300

**FILTROS MOTORES DE GASOLINA 361**

- FILTROS DECANTADORES 361
- FILTROS DE GASOLINA 361
- FILTROS CARBURADOR 362
- FILTROS ACEITE 363

**FILTROS MOTORES DE DIESEL 363**

- FILTROS CON CAZOleta Y ELEMENTOS 363
- FILTROS DECANTADORES DE DIESEL 364
- FILTROS TIPO SEPAR 2000 365
- PRE-FILTROS 365
- FILTROS COMBUSTIBLE 365
- FILTROS ACEITE 366
- FILTROS REFRIGERANTE 368
- FILTROS DE AIRE 368
- FILTROS DESVAPORIZADORES 369
- RÁCORES 369

ACCESORIOS PARA FILTROS 370

**BOMBAS DE COMBUSTIBLE 371**

- BOMBAS MECÁNICAS 371
- BOMBAS ELÉCTRICAS ALTA PRESIÓN 372
- BOMBAS ELÉCTRICAS BAJA PRESIÓN 373
- KIT BOMBA ALTA PRESIÓN 373

**INYECTORES 374**

- KITS CAMISA INYECTOR Y JUNTAS 375

**CARBURADORES 376**

- ADAPTADOR HOLLEY 377
- KIT TORNILLOS 377
- JUNTAS 377
- BOYAS 377
- TUBO COMBUSTIBLE BOMBA 377
- GUÍA KITS CARBURADOR Y BOYAS 378
- KITS CARBURADOR 378

**TURBOS 380**

## SISTEMA ELÉCTRICO

**SENSORES 383**

- TEMPERATURA AIRE 383
- VÁLVULA DE RALENTÍ. IAC 383
- TEMPERATURA AGUA 383
- AGUA EN COMBUSTIBLE 384
- TEMPERATURA Y ACEITE CON ALARMA 384
- PRESIÓN DE ACEITE 384
- POTENCIÓMETRO MANDO 385
- POSICIÓN CIGÜEÑAL 385
- POSICIÓN ÁRBOL DE LEVAS 386
- SENSOR TPS 386
- REGULADOR VOLTAJE 386
- PICADO 387
- VACUÓMETRO. MAP 387

**PÁG**

344 • BOMBILLA INSTRUMENTOS 387

**COMPRESOR 387**

- MÓDULO ELECTRÓNICO 387
- EMBRAGUE 387

**DISTRIBUIDORES 388**

- COMPONENTES 388
- DISTRIBUIDORES 391
- DESPIECES DISTRIBUIDORES 392
- KITS DE CONVERSIÓN ELECTRÓNICO 394

**ENCENDIDO 394**

- MÓDULO DE ENCENDIDO 394
- BOBINAS 395
- BUJÍAS Y CABLES 396

**MOTORES DE ARRANQUE 398**

- EXTENSOR DE SOLENOIDE 400
- LLAVES DE ARRANQUE 401

**ALTERNADORES 401**

RELÉS 403

FUSIBLE 404

SOLENOIDES 405

**TRIM / TILT 406**

- DEPÓSITO 407
- PISTONES Y KITS 407
- TUBO CILINDRO TRIM 408
- KITS REPARACIÓN 408
- DESPIECE TRIM 408
- LATIGUILLOS 409
- DESPIECES LATIGUILLOS 410
- HERRAMIENTAS 411
- SENSORES TRIM 411

**UNIDADES DE TRANSMISIÓN**

**PÁG**

PISTONES DIRECCIÓN 412

BOMBA HIDRÁULICA DIRECCIÓN 412

KITS FUELLES PISTONES DIRECCIÓN 412

KITS LATIGUILLOS 412

KITS REPARACIÓN PISTÓN 412

SERVO BOMBA 413

CILINDRO DIRECCIÓN 413

**DESPIECES COLAS 413**

**GUÍA RODAMIENTOS Y RETENES TRANSOM 440**

KITS REPARACIÓN 441

RETENES Y TÓRICAS 446

FUELLES TRANSMISIÓN Y ESCAPE 447

MANGUITOS ESCAPE 448

MANGUITOS COLA 449

GOMA PASACASCOS 449

ACOPLAMIENTOS 450

COJÍN GOMA 450

PRENSAESTOPAS 450

DAMPER 450

SOPORTES ELÁSTICOS 451

**ÁNODOS 451**

**CORREAS Y COMPONENTES 460**

- PIÑÓN CIGÜEÑAL 460
- PIÑÓN ÁRBOL DE LEVAS 460
- CORREA DISTRIBUCIÓN 460
- TAPÓN SEGURIDAD CORREAS 460
- TENSOR CORREA SERPENTÍN 460
- TENSÍOMETRO 461
- GUÍAS DE CORREAS 462

**HÉLICES 465**

**GUÍAS DE MANTENIMIENTO 471**

**GUÍA ÁNODOS 478**

**GUÍA MANTENIMIENTO COLAS Y KITS 478**

ACEITES PARA MOTOR 480

MATERIALES GENÉRICOS PARA REVISIÓN 481

**ÍNDICE REF 482**



**TABLE OF CONTENTS**

<b>ENGINE PARTS</b>	<b>PÁG</b>				
FEL-PRO GASKETS	274				
<b>GAS ENGINE GASKET</b>	<b>286</b>				
• CYLINDER HEAD GASKET	286				
• GASKET HEAD SETS	286				
• VALVE COVER GASKET	287				
• INTAKE & EXHAUST GASKET	288				
• OIL PAN GASKET	288				
• CONVERSION GASKET SETS	289				
<b>DIESEL ENGINE GASKET</b>	<b>290</b>				
• CYLINDER HEAD GASKET	290				
• GASKET HEAD SETS	292				
• VALVE COVER GASKET	296				
• SEAL SIDE COVER GLOCK	297				
• EXHAUST MANIFOLD & ELBOW GASKET	297				
• TURBO GASKET SET	298				
• REAR CRANKSHAFT COVER GASKET	299				
• TIMING COVER GASKET	299				
• OIL PAN GASKET	299				
• CONVERSION GASKET SETS	300				
CRANKSHAFT SEAL	303				
<b>PISTONS</b>	<b>304</b>				
• PISTONS SET	304				
• CYLINDER LINER & RINGS KITS	305				
• MAIN BEARING KITS	307				
• CONNECTING ROD BERING KIT	310				
• BEARING KIT FOR CAM SHAFTS	312				
<b>VALVES</b>	<b>313</b>				
• SEALS	313				
• INTAKE & EXHAUST VALVES	314				
• GUIDES	315				
• SPRINGS	315				
• VALVE KEEPER	316				
• LIFTER	316				
• VALVE DEPRESSOR	316				
<b>FIXING COMPONENTS</b>	<b>316</b>				
• BOLT KIT & NUT OF CYLINDER HEAD	316				
• RUBBER WASHER FOR CAMSHAFT	316				
• EXPANSION PLUG	316				
<b>EXHAUST &amp; INTAKE SYSTEM</b>	<b>PÁG</b>				
• MANIFOLDS & ELBOWS PARTS	317				
• FUEL EXHAUST MANIFOLDS	325				
• FUEL EXHAUST ELBOWS	326				
• EXHAUST EXTENSIONS	327				
• EXHAUST TUBO SX	328				
• DIESEL EXHAUST ELBOWS	328				
• DIESEL EXHAUST ELBOWS STAINLESS	329				
• INTAKE MANIFOLD	330				
• EXHAUST ELBOW APPLICATION	331				
<b>COOLING SYSTEM</b>	<b>PÁG</b>				
OIL COOLER	332				
<b>BLOCK CIRCULATING PUMP</b>	<b>332</b>				
• WATER PUMP FOR FUEL ENGINES	332				
• GASKETS FOR FUEL ENGINES	333				
• WATER PUMP FOR DIESEL ENGINES	333				
• WATER PUMP REPAIR KIT	334				
• GASKETS FOR DIESEL ENGINES	334				
• HOSES	334				
• PUMP APPLICATION	335				
SEA WATER FILTER	336				
<b>RAW MARINE WATER PUMPS</b>	<b>337</b>				
• PUMP STOP	342				
• PUMP CONSOLES	342				
• WATER PUMP BEARING	342				
• SCREWS	343				
• EXPANSION DEPOSIT COVER	343				
• GASKET KITS	343				
		• CROSS PIECES	344	• MAP	387
		• IMPELLERS	344	• BULB WATHC INSTRUMENTS	387
		• IMPELLERS APPLICATION	347	<b>COMPRESOR</b>	<b>387</b>
		• WATER PUMP SERVICE KITS	348	• ELECTRONIC MODULE	387
		• WATER PUMP SEALS	350	• CLUTCH	387
		• ENGINE HOSES SEALS	350	<b>DISTRIBUTOR</b>	<b>388</b>
		• DRAIN TAPS	352	• COMPONENTS	388
		<b>THERMOSTAT</b>	<b>353</b>	• DISTRIBUTORS	391
		• KITS	353	• DISTRIBUTORS PARTS	392
		• HOUSING	355	• ELECTRONIC CONVERSION KITS	394
		• GASKETS	355	<b>IGNITION</b>	<b>394</b>
		<b>HEAT EXCHANGERS</b>	<b>356</b>	• IGNITION MODULES	394
		• SEALS & GASKETS KIT	356	• COILS	395
		<b>AFTERCOOLER</b>	<b>358</b>	• SPARK PLUGS & WIRES	396
		• SEALS KIT	359	<b>STARTERS</b>	<b>398</b>
				• SOLENOID EXTENSOR FOR TERMINALS	400
				• START KEYS	401
		<b>FUEL &amp; FILTRATION SYSTEM</b>	<b>PÁG</b>	<b>ALTERNATORS</b>	<b>401</b>
		<b>FUEL FILTERS</b>	<b>360</b>	• RELAY	403
		• BRACKETS	360	• FUSES	404
		• WATER SEPARATING FUEL FILTER	360	• SOLENOID	405
		• RACORS	360	<b>TRIM / TILT</b>	<b>406</b>
		<b>FILTERS GAS ENGINES</b>	<b>361</b>	• TRIM TANK	407
		• COMPLETE FUEL FILTER	361	• PISTONS & KITS	407
		• FUEL FILTERS	361	• TRIM CYLINDER TUBE	408
		• CARBURATOR FILTERS	362	• REPAIR KIT	408
		• OIL FILTERS	362	• TRIM PARTS	408
		<b>FILTERS DIESEL ENGINES</b>	<b>363</b>	• TRIM HOSES	409
		• BOWL FILTERS & ELEMENTS	363	• TRIM HOSES PARTS	410
		• COMPLET DIESEL FILTERS	364	• TOOLS	411
		• FILTERS TYPE SEPAR 2000	365	• TRIM POSITION SENDER	411
		• PRE-FILTERS	365		
		• DIESEL FILTERS	365	<b>UNIT DRIVES &amp; COMPONENTS</b>	<b>PÁG</b>
		• OIL FILTERS	366	STEERING PISTON	412
		• COOLANT FILTERS	368	HYDRAULIC STEERING PUMP	412
		• AIR FILTERS	368	KIT BELLOWS STEERING PISTON	412
		• DEALERS FILTERS	369	HYDRAULIC HOSES KITS	412
		• RACORS	369	PISTON REPAIR KIT	412
		FILTERS ACCESSORIES	370	SEVO PUMP	413
		<b>FUEL PUMP</b>	<b>371</b>	STEERING CYLINDER	413
		• MECHANIC FUEL PUMP	371	<b>GEARCASE PARTS</b>	<b>414</b>
		• HIGH PRESSURE ELECTRIC PUMP	372	<b>FLYWHEEL CASING REPAIR KITS GUIDE</b>	<b>440</b>
		• LOW PRESSURE ELECTRIC PUMP	373	REPAIR KITS	441
		• HIGH PRESSUER FUEL PUMP KITS	373	SEALS & RUBBER O-RINGS	446
		<b>INJECTORS</b>	<b>374</b>	DRIVE BELLOW & EXHAUST BELLOW	447
		• INJECTOR SLEEVE KIT & GASKETS	375	EXHAUST HOSES	448
		<b>CARBURETORS</b>	<b>376</b>	DRIVE HOSES	449
		• HOLLEY ADAPTOR	377	THRU HULL BELLOW	449
		• CARBURETOR STUD KIT STD	377	COUPLERS	450
		• GASKETS	377	RUBBER BLOCK FOR ENGINE SUSPENTION	450
		• FLOATS	377	RUBBER SEAL KIT	450
		• FUEL TUBE PUMP-CARBURETOR	377	DRIVE PLATE	450
		• CARBURETOR & FLOATS APPLICATION	378	FLEXIBLE ENGINE MOUNTS	454
		• GASKETS & KITS	378	<b>ANODES</b>	<b>451</b>
		<b>TURBOS</b>	<b>380</b>	<b>BELTS &amp; COMPONENTS</b>	<b>460</b>
				• CRANKSHAFT GEAR	460
				• CAMSHFT GEAR	460
				• TIMING BELT	460
		<b>ELECTRIC SYSTEM</b>	<b>PÁG</b>	• PLUG SAFETY COVER BELTS	460
		<b>SENDERS</b>	<b>383</b>	• TENSIONER & PULLEY	460
		• AIR TEMPERATURE	383	• TENSIONER	461
		• IDLE VALVE. IAC	383	• BELTS GUIDES	462
		• WATER TEMPERATURE	383	<b>PROPELLERS &amp; APPLICATION</b>	<b>465</b>
		• WATER IN FUEL	384	<b>GUIDES OF MANTENANCE</b>	<b>471</b>
		• TEMPERATURA & OIL PRESSURE		<b>ANODES GUIDE</b>	<b>478</b>
		WARNING KIT	384	<b>DRIVES MAINTENANCE GUIDE &amp; KITS</b>	<b>478</b>
		• OL PRESSURE	384	ENGINES OIL	480
		• CONTROL POTENTIOMETER	385	GENERIC MATERIALS FOR REVISION	481
		• CRANKSHAFT POSITION	385		
		• CAMSHAFT	386	<b>REF TABLE</b>	<b>482</b>
		• TPS	386		
		• VOLTAGE REGULATOR	386		
		• KNOCK	387		





# JUNTAS PARA BASES GM Y FORD MARINE GASKETS TO GM & FORD ENGINES GUARNIZIONI PER MOTORI GM E FORD



Los Kits FEL-PRO, están diseñados y catalogados específicamente para aplicaciones marinas. Su calidad es superior a las juntas originales.  
FEL-PRO gaskets kits are designed and cataloged specifically for marine engine applications. Their quality is even better than the oem's.  
I kit di guarnizioni FEL-PRO, sono disegnati e fabbricati specificatamente per applicazioni marine. La qualità è assolutamente paragonabile a quelle originali.

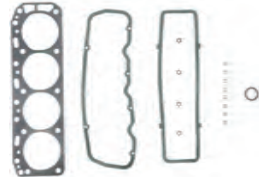

SERIE SERIAL SERIE	Descripción	Description	Descrizione
FEL17000 - FEL17099	KIT JUNTAS DE CULATA en pack individual.	CYLINDER HEAD gasket single-packed	Guarnizioni TESTATA quantità 1
FEL17100 - FEL17199	<b>KIT DE CONVERSIÓN</b> Todas las juntas y retenes de aceite que no se encuentran en los juegos de culata y que son necesarios para completar el acoplamiento del motor (incluye las juntas del cárter y los retenes).	<b>CONVERSION KITS</b> All gaskets and oil seals not found in a Head Set, that are necessary for a complete engine overhaul. This includes timing cover gaskets and seals, oil pan gaskets, and rear main bearing seals.	<b>KIT PARTE BASSA</b> Include tutte le guarnizioni ed i paraolio della parte bassa del motore, viene fornita anche la guarnizione della coppa dell'olio.
FEL17200 - FEL17299	<b>KIT DE DESCARBONIZACIÓN</b> Todas las juntas y retenes necesarios para el trabajo de las válvulas, incluyendo la junta de culata, la tapa de la válvula y juntas de colector de admisión y colector de escape. (Los kits de 4 cyl no contienen las juntas del colector de admisión/escape. Deben pedirse por separado).	<b>HEAD SETS SERIES</b> All gaskets and seals necessary for a valve grinding job, including cylinder head gaskets, valve cover gaskets, intake & exhaust manifold gaskets (except 4 cyl intake set), and valve stem seals.	<b>KIT PARTE ALTA (SMERIGLIO)</b> Include tutte le guarnizioni ed i paraolio della parte alta del motore, testate, carter distribuzione, aspirazione e scarico. (motori a 4 cyl. la guarnizione aspirazione è da ordinare separatamente).
FEL17300 - FEL17399	<b>KIT DE COLECTOR DE ADMISIÓN</b> Juntas de la parte de admisión del colector, retenes y juntas de la base del distribuidor.	<b>INTAKE MANIFOLD SETS</b> Intake manifold side gaskets, intake manifold end seals, and distributor mounting gasket.	<b>KIT GUARNIZIONE ASPIRAZIONE</b> Tutte le guarnizioni
FEL17400 - FEL17499	<b>KIT DE COLECTOR DE ESCAPE</b> (De colector a culata)	<b>EXHAUST MANIFOLD</b> (Manifold-to-cylinder head) gaskets.	<b>KIT GUARNIZIONE SCARICO</b> (dalla testata al collettore)
FEL17700 - FEL17749	<b>KIT DE CONTRARROTACIÓN RETÉN TRASERO DEL CIGÜEÑAL</b> Retenes traseros del cigüeñal diseñados para motores de rotación opuesta a la normal. (Retenes de rotación normal incluidos en el set de conversión)	<b>REVERSE ROTATION REAR MAIN BEARING SEAL SETS</b> Rear main bearing seals designed to seal a crankshaft which rotates in the opposite direction from normal (Standard rotation seal is included in conversion set)	<b>PARAOLIO MOTORI CONTROROTANTI ALBERO MOTORE</b> Nei motori rotazione STD il paraolio viene già incluso nel kit della parte bassa.
FEL17750 - FEL17799	<b>KIT DE RETENES TAPA DEL CIGÜEÑAL DE CONTRARROTACIÓN</b> Retenes de la tapa del cigüeñal diseñados para motores de rotación opuesta a la normal. (Retenes de rotación normal incluidos en el kit de conversión).	<b>REVERSE ROTATION TIMING COVER SEAL SETS SERIES</b> Timing cover seals designed to seal crankshaft which rotates in the opposite direction from normal (standard rotation seal is included in Conversion set and Timing cover set)	<b>PARAOLIO CARTER DISTRIBUZIONE CONTROTOTANTI</b> Modelli rotazione STD, incluso nella parte bassa.
FEL17900 - FEL17949	<b>KIT DE TAPA VÁLVULA</b> Todas las juntas de las tapas de las válvulas para sellar el motor.	<b>VALVE COVER SET SERIES</b> All valve cover or push rod cover gaskets (and grommets if required) required to seal one engine.	<b>KIT COPERCHIO PUNTERIE</b> Tutte le guarnizioni
FEL17950 - FEL17999	<b>KIT DE CÁRTER</b> Todas las juntas del cárter.	<b>OIL PAN SETS SERIES</b> All oil pan gaskets & seals, or one-piece molded rubber oil pan gasket, required to seal one engine.	<b>GUARNIZIONE COPPA DELL'OLIO</b> Tutte le guarnizioni

## 3.0 GS (135-150 HP), GL (135 HP), GXI (150 HP)

Ref	R.O. OEM	Descripción	Description	Descrizione
		<b>CULATA</b>	<b>CYLINDER HEAD</b>	<b>TESTATA</b>
	FEL17000 3853336	JUNTA CULATA	CYLINDER HEAD	GUARNIZIONE TESTATA
	FEL17200	<b>KIT JUNTAS SUPERIOR</b> No incluye juntas colector escape/admisión	<b>GASKET HEAD SET</b> Intake & Exhaust manifold gasket not included	<b>KIT PARTE ALTA</b> Non include guarnizioni collettore scarico / aspirazione
	FEL17102	<b>KIT JUNTAS INFERIOR</b> Retén 1 piezas, 1 pieza junta cárter.	<b>CONVERSION GASKET SET</b> 1 piece rear main bearing seal & 1 piece oil pan gasket	<b>KIT PARTE BASSA</b> Paraolio in 1 pz, 1 pz guarnizione coppa dell'olio.
	FEL17304 3853256	<b>COLECTOR ADMISIÓN-ESCAPE</b> Junta Admisión-Escape	<b>MANIFOLD INTAKE &amp; EXHAUST</b> Intake-Exhaust Gasket	<b>ASPIRAZIONE - SCARICO</b> Guarnizione aspirazione - scarico

Ref	R.O. OEM	Descripción	Description	Descrizione
		<b>TAPA VÁLVULAS</b>	<b>VALVE COVER</b>	<b>COPERCHIO VALVOLE</b>
 FEL17900	3852693	Junta tapa de válvulas	Gasket	Guarnizione
		<b>TAPA EMPUJADORES</b>	<b>PUSH ROD COVER</b>	<b>COPERCHIO ASTE PUNTERIE</b>
 FEL17903	3856443	Junta tapa de empujadores	Gasket push rod cover	Guarnizione coperchio aste punterie

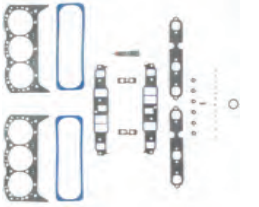
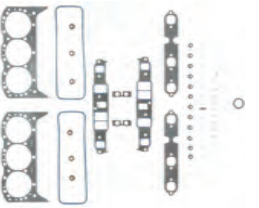
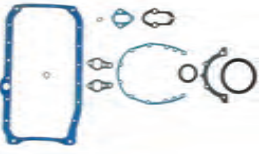
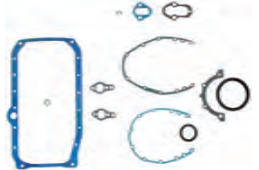
**4.3 GI (205 HP); 4.3 GL (190 HP); 4.3 GS (205 HP); 4.3 GXI (225 HP);  
430, 430 DP (155 HP); 431 (180 HP); 431 (205 HP);  
432 DP (164 HP); 434 DP (187 HP)**

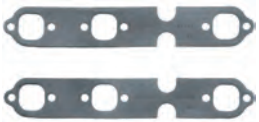
Ref	R.O. OEM	Descripción	Description	Descrizione
		<b>CULATA</b>	<b>CYLINDER HEAD</b>	<b>TESTATA</b>
 FEL17010	3854299	JUNTA CULATA Se necesitan dos	CYLINDER HEAD 2 required	GUARNIZIONE TESTATA Ne servono 2
 FEL17210		KIT JUNTAS SUPERIOR Motor sin eje equilibrado. Incluye juntas tapa válvulas y retenes.	GASKET HEAD SET Engine without balance shaft; valve cover gaskets and premium valve stem seals incl.	KIT PARTE ALTA Motore senza asse bilanciato. Incluye guarnizione coperchio punterie e paraoli valvole.
 FEL17211		KIT JUNTAS SUPERIOR Motor con eje equilibrado. Incluye juntas tapa válvulas y retenes.	GASKET HEAD SET Engine with balance shaft; valve cover gaskets and premium valve stem seals incl.	KIT PARTE ALTA Motore con asse bilanciato. Incluye guarnizione coperchio punterie e paraoli valvole.
		<b>INFERIOR</b>	<b>CONVERSION</b>	<b>PARTE BASSA</b>
 FEL17115		KIT JUNTAS INFERIOR Motor sin eje equilibrado con retén de una pieza y 1 pieza junta cárter, incluye junta de cárter.	CONVERSION GASKET SET Engine without balance shaft with one-piece rear main bearing seal & 1 piece oil pan gasket; oil pan gasket incl.	KIT PARTE BASSA Motore senza asse bilanciato. Paraolio post in 1 pz e guarnizione coppa in 1 pz.
 FEL17116		KIT JUNTAS INFERIOR Motor con eje equilibrado con retén de 1 pieza y 1 pieza junta cárter, incluye junta de cárter.	CONVERSION GASKET SET Engine without balance shaft with one-piece rear main bearing seal & 1 piece oil pan gasket; oil pan gasket incl.	KIT PARTE BASSA Motore con asse bilanciato. Paraolio post in 1 pz e guarnizione coppa in 1 pz.
		<b>COLECTOR ADMISIÓN- ESCAPE</b>	<b>MANIFOLD INTAKE &amp; EXHAUST</b>	<b>ASPIRAZIONE - SCARICO</b>
 REC 824326002	3855807	Junta admisión Vortec (2 unid.)	Intake gasket Vortec (2 units)	guarnizione aspirazione Vortec (2 unità)
 FEL17310	857177	Kit junta admisión PRE-VORTEC	Intake-Exhaust gasket set PRE-VORTEC	Kit guarnizioni aspirazione PRE-VORTEC
 FEL17410	3853412	Kit junta escape	Exhaust gasket set	Kit guarnizioni aspirazione

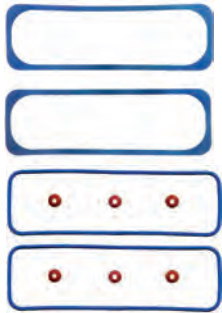
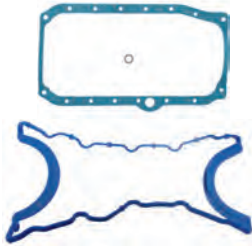

Ref	R.O. OEM	Descripción	Description	Descrizione
		<b>CÁRTER</b>	<b>OIL PAN</b>	<b>COPPA DELL'OLIO</b>
FEL17971	3852655	1 junta cárter (Retén 1 pieza)	1 piece oil pan gasket (1 piece seal)	Guarnizione coppa in 1 pz (paraolio 1 pz)
REC27- 142471		1 Junta cárter (Cárter aluminio)	1 rubber oil pan gasket (oil pan in alluminium)	Guarnizione 1 pz (coppa in alluminio)
		<b>TAPA VÁLVULAS</b>	<b>VALVE COVER</b>	<b>COPERCHIO VALVOLE</b>
FEL17920	3854300	KIT JUNTA TAPA VÁLVULAS Motor sin eje equilibrado.	GASKET SET Engine without balance shaft.	GUARNIZIONE COPERCHIO PUNTERIE Motore senza asse equilibrato.
FEL17921	3854942	KIT JUNTA TAPA VÁLVULAS Motor con eje equilibrado.	GASKET SET Engine with balance shaft.	GUARNIZIONE COPERCHIO PUNTERIE Motore con asse equilibrato.

**5.0 FI (220 HP); 5.0FL (190 HP); 215 (215 HP); 220 (220 HP); 225 (225 HP)  
BASE FORD / FORD BLOCK / BASE FORD**

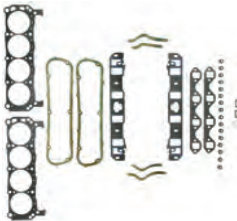
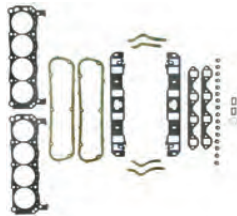
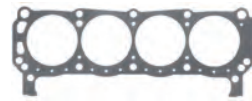

Ref	R.O. OEM	Descripción	Description	Descrizione
		<b>CULATA</b>	<b>CYLINDER HEAD</b>	<b>TESTATA</b>
FEL17060		JUNTA CULATA Se necesitan dos	CYLINDER HEAD 2 required	GUARNIZIONE TESTATA Se necessitano 2
FEL17261		KIT JUNTAS SUPERIOR Con tapa válvulas de aluminio. Incluye retenes de válvulas.	GASKET HEAD SET With cast aluminum valve covers. Premium valve stem seals included.	KIT PARTE ALTA Con coperchio punterie in alluminio, include paraolio valvole.
FEL17260		KIT JUNTAS SUPERIOR Incluye retenes válvulas. Con tapa válvulas acero.	GASKET HEAD SET Premium valve stem seals incl. Cast steel valve covers.	KIT PARTE ALTA Include paraoli valvole. Con coperchio valvole in acciaio.
		<b>INFERIOR</b>	<b>CONVERSION</b>	<b>PARTE BASSA</b>
FEL17161		KIT JUNTAS INFERIOR Retén 1 piezas, 1 pieza junta cárter, incluye junta de cárter.	CONVERSION GASKET SET 1 piece rear main bearing seal & 1 piece oil pan gasket, rubber oil pan gasket included.	KIT PARTE BASSA Paraolio in 1 pz, 1 pz guarnizione coppa dell'olio.
FEL17160		KIT JUNTAS INFERIOR Retén 2 piezas, 4 pieza junta cárter.	CONVERSION GASKET SET 2 piece rear main bearing seal & 4 piece oil pan gasket.	KIT PARTE BASSA Paraolio in 2 pz, 3 pz guarnizione coppa dell'olio.

Ref	R.O. OEM	Descripción	Description	Descrizione
		<b>COLECTOR ADMISIÓN-ESCAPE</b>	<b>MANIFOLD INTAKE &amp; EXHAUST</b>	<b>ASPIRAZIONE - SCARICO</b>
FEL17360		KIT JUNTA ADMISIÓN	INTAKE GASKET SET	KIT GUARNIZIONE ASPIRAZIONE
FEL17460	3852455	KIT JUNTA ESCAPE	EXHAUST GASKET SET	KIT GUARNIZIONE SCARICO
		<b>CÁRTER</b>	<b>OIL PAN</b>	<b>COPPA DELL'OLIO</b>
FEL17995		KIT JUNTAS CÁRTER 4 Piezas	GASKET OIL PAN SET 4 Pieces	KIT GUARNIZIONE 4 pz
FEL17997		JUNTA CÁRTER 1 pieza junta de goma.	GASKET OIL PAN 1 piece oil pan gasket	GUARNIZIONE 1 pz
		<b>TAPA VÁLVULAS</b>	<b>VALVE COVER</b>	<b>COPERCHIO VALVOLE</b>
FEL17946		KIT JUNTA TAPA VÁLVULAS Con tapa válvulas de aluminio.	GASKET SET With cast aluminium valve covers.	GUARNIZIONE COPERCHIO PUNTERIE Con coperchio valvole in alluminio.
FEL17945		KIT JUNTA TAPA VÁLVULAS Con tapa válvulas de acero.	GASKET SET With cast steel valve covers.	GUARNIZIONE COPERCHIO PUNTERIE con coperchio valvole in acciaio.

**5.OGX1 (270HP); AQ200 (200 HP); AQ211 (210 HP); AQ225 (225 HP); AQ231 (229 HP); BB225 (225HP); BB231 (229 HP); 500 DP (187 HP); 500 DP (190 HP); 501, 501 DP (204 HP); 501, 501 DP (205 HP)**

Ref	R.O. OEM	Descripción	Description	Descrizione
		<b>CULATA</b>	<b>CYLINDER HEAD</b>	<b>TESTATA</b>
FEL17020	3853380	JUNTA CULATA Se necesitan dos	CYLINDER HEAD 2 required	GUARNIZIONE TESTATA Ne servono 2
FEL17224		KIT JUNTAS SUPERIOR Tornillo centro tapa válvulas. Incluye retenes válvulas.	GASKET HEAD SET With center bolt desing valve covers. Premium valve stem seals incl.	KIT PARTE ALTA Viti coperchio punterie al centro. Include paraoli valvole.
FEL17220		KIT JUNTAS SUPERIOR Tornillo en el lateral tapa válvulas. Incluye retenes válvulas.	GASKET HEAD SET Rim bolt desing valve covers; Premium valve stem seals incl.	KIT PARTE ALTA Viti coperchio punterie nel perimetro. Include paraoli valvole.
		<b>INFERIOR</b>	<b>CONVERSION</b>	<b>PARTE BASSA</b>
FEL17125		KIT JUNTAS INFERIOR retén 1 pieza, 1 pieza junta cárter	CONVERSION GASKET SET 1 piece rear main bearing seal & 1 piece oil pan gasket	KIT PARTE BASSA Paraolio in 1 pz, 1 pz guarnizione coppa dell'olio.

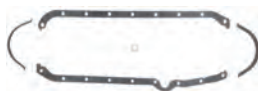
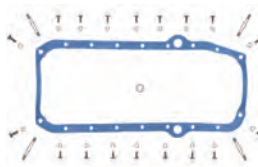
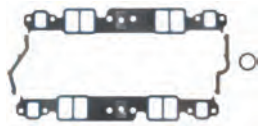
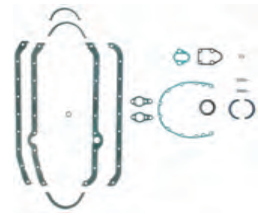

Ref	R.O. OEM	Descripción	Description	Descrizione
FEL17120		KIT JUNTAS INFERIOR Retén 2 piezas, 4 piezas junta cárter.	CONVERSION GASKET SET 2 piece rear main bearing seal & 4 piece oil pan gasket.	KIT PARTE BASSA Paraolio in 2 pz, 3 pz guarnizione coppa dell'olio.
		<b>COLECTOR ADMISIÓN- ESCAPE</b>	<b>MANIFOLD INTAKE &amp; EXHAUST</b>	<b>ASPIRAZIONE - SCARICO</b>
FEL17320	856365	KIT juntas admisión	Intake gasket kit	Kit guarnizioni aspirazione
REC27- 807473A1	3857662	Kit juntas admisión VORTEC	Intake gasket kit VORTEC	Kit guarnizioni aspirazione VORTEC
FEL17420	856034	Kit juntas escape	Exhaust gasket kit	Kit guarnizioni scarico
		<b>CÁRTER</b>	<b>OIL PAN</b>	<b>COPPA DELL'OLIO</b>
FEL17982	3856138	1 pieza junta cárter.	1 piece oil pan gasket.	1 pz
FEL17983		1 pieza junta goma, retén 2 piezas.	1 pieces molded rubber, 2 pieces seal.	1 pz, paraolio in 2 pz.
FEL17980	855729	Varilla aceite a babor con retén de 2 piezas y junta cárter de 4 piezas.	Port dipstick with 2 pieces rear main bearing seal & 4 pieces oil pan gasket.	Asticella olio a babordo, motore con paraolio in 2 pz e guarnizione.
FEL17981		Varilla aceite a estribor con retén trasero de dos piezas y junta cárter de 4 piezas.	Starboard dipstick with 2 pieces rear main bearing seal & 4 pieces oil pan gasket.	Asticella olio a tribordo, motore con paraolio posteriore albero motore in 2 pz e guarnizione.
		<b>RETÉN TRASERO CIGÜENAL</b>	<b>CRANKSHAFT REAR SEAL</b>	<b>PARAOLIO POSTERIORE ALBERO MOTORE</b>
FEL17725		Contrarrotación, 1 pieza.	Rev. rotation, rubber; 1 piece.	Controrotante, in 1 pz.
		<b>TAPA VÁLVULAS</b>	<b>VALVE COVER</b>	<b>COPERCHIO VALVOLE</b>
FEL17931	3852687	KIT JUNTA TAPA VÁLVULAS Tornillo centro tapa válvulas.	GASKET SET With center bolt desing valve covers.	GUARNIZIONE COPERCHIO PUNTERIE Coperchio con viti al centro.



Ref	R.O. OEM	Descripción	Description	Descrizione
FEL17930	835096	KIT JUNTA TAPA VÁLVULAS Tornillo en el lateral.	GASKET SET Rim bolt desing.	GUARNIZIONE COPERCHIO PUNTERIE Coperchio con viti nel perimetro.
		<b>TAPA DISTRIBUCIÓN</b>	<b>TIMING COVER</b>	<b>COPERCHIO CÁRTER DISTRIBUZIONE</b>
REC3853341	3853341	RETÉN ACEITE Retén tapa distribución.	OIL SEAL Rev. rotation timing cover seal.	PARAOLIO Paraolio coperchio.

**AQ260 (260 HP); AQ271 (270 HP); AQ271 (275 HP); AQ290 (290 HP);  
AQ311 (307 HP); BB260, BB261 (260 HP); 5.7 GI (250 HP);  
5.7 GL (215 HP), GXI (320HP); 570, 570 DP (245 HP); 571 (273 HP); 572 (225HP)**

Ref	R.O. OEM	Descripción	Description	Descrizione
		<b>CULATA</b>	<b>CYLINDER HEAD</b>	<b>TESTATA</b>
FEL17030	3853380	JUNTA CULATA Se necesitan 2	CYLINDER HEAD 2 required	GUARNIZIONE TESTATA Ne servono 2
FEL17214		KIT JUNTAS SUPERIOR Tornillo centro tapa válvulas. Retenes válvulas incluidos. PREVORTEC	GASKET HEAD SET With center bolt desing valve covers. Seals incl. PREVORTEC	KIT PARTE ALTA Viti coperchio punterie nel centro. Paraoli valvole inclusi. PERVORTEC
FEL17230		KIT JUNTAS SUPERIOR Tornillo borde tapa válvulas. Retenes válvulas incluidos. PREVORTEC	GASKET HEAD SET With rim bolt desing valve covers; Seals incl. PREVORTEC	KIT PARTE ALTA Viti coperchio punterie nel perimetro. Paraoli valvole inclusi. PREVORTEC
FEL17232		KIT JUNTAS SUPERIOR Juntas de plástico colector admisión. Retenes válvulas incluidos. VORTEC	GASKET HEAD SET Whith plastic intake manifold gaskets. Premium valve stem. Seals incl. VORTEC	KIT PARTE ALTA Con guarnizione aspirazione in plastica. Paraoli valvole inclusi. VORTEC
		<b>INFERIOR</b>	<b>CONVERSION</b>	<b>PARTE BASSA</b>
FEL17125		KIT JUNTAS INFERIOR Retén 1 pieza, 1 pieza junta cárter. Tapa distribución metálica.	CONVERSION GASKET SET 1 piece bearing seal & 1 piece oil pan gasket. Metallic cover.	KIT PARTE BASSA Paraolio in 1 pz, 1 pz guarnizione coppa dell'olio. Coperchio metal.
FEL17124		KIT JUNTAS INFERIOR Con tapa de distribución de plástico, retén de 1 pieza y junta cárter de 1 pieza.	CONVERSION GASKET SET Engine with plastic timing cover, with 1 piece bearing seal & 1 piece oil pan gasket.	KIT PARTE BASSA Cárter distribuzione in plastica, paraolio in 1 pz e guarnizione coppa olio in 1 pz.



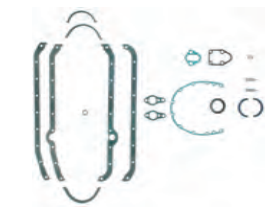

Ref	R.O OEM	Descripción	Description	Descrizione
FEL17120		KIT JUNTAS INFERIOR Retén 2 piezas y junta cárter de 4 piezas.	CONVERSION GASKET SET 2 pieces bearing seal & 4 pieces oil pan gasket.	KIT PARTE BASSA Paraolio in 2 pz e guarnizione coppa olio in 4 pz.
		<b>COLECTOR ADMISIÓN-ESCAPE</b>	<b>MANIFOLD INTAKE &amp; EXHAUST</b>	<b>ASPIRAZIONE - SCARICO</b>
FEL17320		Junta admisión PRE-VORTEC	Intake gasket PRE-VORTEC	Guarnizione aspirazione PRE-VORTEC
REC27-807473A1	3857662	JUEGO JUNTAS ADMISIÓN VORTEC Junta de plástico.	VORTEC INTAKE GASKET SET Plastic gasket.	KIT VORTEC Guarnizione in plastica
FEL17420		KIT JUNTA ESCAPE	EXHAUST GASKET KIT	KIT GUARNIZIONE SCARICO
		<b>CÁRTER</b>	<b>OIL PAN</b>	<b>COPPA DELL'OLIO</b>
FEL17982		KIT JUNTAS CÁRTER 1 pieza junta cárter.	GASKET OIL PAN SET 1 piece oil pan gasket.	KIT GUARNIZIONE 1 pz
FEL17983		KIT JUNTAS CÁRTER 1 pieza junta para motores con retén trasero de 2 piezas.	GASKET OIL PAN SET 1 piece rubber gasket for engines with 2 pieces rear main bearing seal.	KIT GUARNIZIONE 1 pz per motori con paraolio posteriore albero motore in 2 pz.
FEL17980	855729	KIT JUNTAS CÁRTER Varilla aceite a babor con retén trasero de 2 piezas y junta cárter de 4 piezas.	GASKET OIL PAN SET Port dipstick with 2 pieces rear main bearing seal & 4 pieces oil pan gasket.	KIT GUARNIZIONE Asticella olio a sinistra, motore con paraolio posteriore albero motore in 2 pz e guarnizione.
FEL17981		KIT JUNTAS CÁRTER Varilla aceite a estribor con retén trasero de 2 piezas y junta cárter de 4 piezas.	GASKET OIL PAN SET Starboard dipstick with 2 pieces rear main bearing seal & 4 pieces oil pan gasket.	KIT GUARNIZIONE Asticella olio a destra, motore con paraolio posteriore albero motore in 2 pz e guarnizione.
		<b>RETÉN TRASERO CIGÜENAL</b>	<b>CRANKSHAFT REAR SEAL</b>	<b>PARAOLIO POSTERIORE ALBERO MOTORE</b>
FEL17725		Contrarrotación; 1 pieza	Rev. rotation; 1 piece	Controrotante, in 1 pz.
		<b>TAPA VÁLVULAS</b>	<b>VALVE COVER</b>	<b>COPERCHIO VALVOLE</b>
FEL17931	3852687	KIT JUNTA TAPA VÁLVULAS Tornillo centro tapa válvulas.	GASKET SET With center bolt desing valve covers.	GUARNIZIONE COPERCHIO PUNTERIE Coperchio con viti al centro.
FEL17930	835096	KIT JUNTA TAPA VÁLVULAS Tornillo en el lateral.	GASKET SET Rim bolt desing.	GUARNIZIONE COPERCHIO PUNTERIE Coperchio con viti nel perimetro.

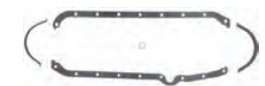
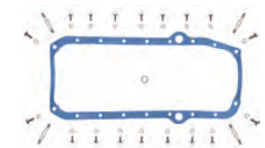
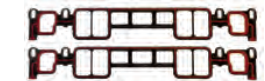
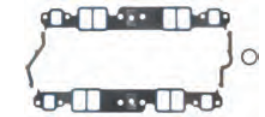



Ref	R.O. OEM	Descripción	Description	Descrizione
		<b>TAPA DISTRIBUCIÓN</b>	<b>TIMING COVER</b>	<b>COPERCHIO CÁRTER DISTRIBUZIONE</b>
REC3853341	3853341	RETÉN ACEITE Retén tapa distribución.	OIL SEAL Timing cover seal.	PARAOLIO Paraolio.

**5.8 FL (235 HP); 5.8 FSI (265 HP); 240 (240 HP)**

Ref	R.O. OEM	Descripción	Description	Descrizione
		<b>CULATA</b>	<b>CYLINDER HEAD</b>	<b>TESTATA</b>
FEL17060		JUNTA CULATA Se necesitan 2	CYLINDER HEAD 2 required	GUARNIZIONE TESTATA Ne servono 2
FEL17261		KIT JUNTAS SUPERIOR Con tapa válvulas de aluminio. Incluye retenes de válvulas.	GASKET HEAD SET With cast aluminum valve covers. Premium valve stem seals included.	KIT PARTE ALTA Co coperchio punterie in alluminio, include paraolio valvole.
FEL17260		KIT JUNTAS SUPERIOR Con tapa de válvulas de acero. Incluye retenes válvulas.	GASKET HEAD SET With cast steel valve covers. Premium valve stem seals incl.	KIT PARTE ALTA Coperchio punterie in acciaio. Include paraoli valvole
		<b>INFERIOR</b>	<b>CONVERSION</b>	<b>PARTE BASSA</b>
FEL17166		KIT JUNTAS INFERIOR Retén 1 pieza, 1 pieza junta cárter.	CONVERSION GASKET SET 1 piece rear main bearing seal & 1 piece oil pan gasket	KIT PARTE BASSA Paraolio in 1 pz, 1 pz guarnizione coppa dell'olio.
FEL17165		KIT JUNTAS INFERIOR Retén 2 piezas, 4 piezas junta cárter.	CONVERSION GASKET SET 2 piece rear main bearing seal & 4 piece oil pan gasket,	KIT PARTE BASSA Paraolio in 2 pz, 4 pz guarnizione coppa dell'olio.
		<b>COLECTOR ADMISIÓN- ESCAPE</b>	<b>MANIFOLD INTAKE &amp; EXHAUST</b>	<b>ASPIRAZIONE - SCARICO</b>
FEL17360		Junta admisión	Intake gasket	Guarnizione aspirazione
FEL17460	3852455	Junta escape	Exhaust gasket	Guarnizione scarico
		<b>CÁRTER</b>	<b>OIL PAN</b>	<b>COPPA DELL'OLIO</b>
FEL17996		KIT JUNTAS CÁRTER 4 piezas junta cárter.	GASKET OIL PAN SET 4 piece oil pan gasket.	KIT GUARNIZIONE 4 pz



Ref	R.O. OEM	Descripción	Description	Descrizione
FEL17998		KIT JUNTAS CÁRTER 1 pieza	GASKET OIL PAN SET 1 piece	KIT GUARNIZIONE 1 pz.
		<b>TAPA VÁLVULAS</b>	<b>VALVE COVER</b>	<b>COPERCHIO VALVOLE</b>
FEL17946		KIT JUNTA TAPA VÁLVULAS Con tapa válvulas de aluminio.	GASKET SET With cast aluminium valve covers.	GUARNIZIONE COPERCHIO PUNTERIE Con coperchio valvole in alluminio.
FEL17945		KIT JUNTA TAPA VÁLVULAS Con tapa válvulas de acero.	GASKET SET With cast steel valve covers.	GUARNIZIONE COPERCHIO PUNTERIE Con coperchio valvole in acciaio.

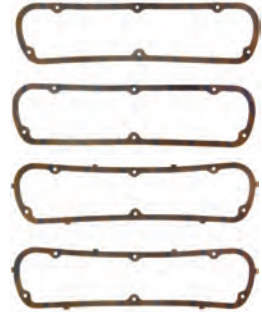

**7.4 GI (330 HP GEN. V); 7.4 GL (300 HP GEN. V); 7.4 GSI (385 HP GEN. V);  
740 (300 HP GEN. IV); 740 DP (300 HP GEN. IV); 740 DP (300 HP GEN. V)**

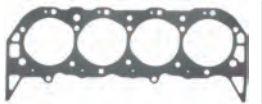

Ref	R.O. OEM	Descripción	Description	Descrizione
		<b>CULATA</b>	<b>CYLINDER HEAD</b>	<b>TESTATA</b>
FEL17040	856575	JUNTA CULATA Gene IV. Se necesitan 2.	CYLINDER HEAD Gene IV. 2 required	GUARNIZIONE TESTATA Gene IV. Ne servono 2.
FEL17042	3853511	JUNTA CULATA Gene V & VI. Se necesitan 2.	CYLINDER HEAD Gene V & VI. 2 required.	GUARNIZIONE TESTATA Gene V & VI. Ne servono 2.
FEL17240		KIT JUNTAS SUPERIOR Gene IV. Se incluyen retenes de válvula.	GASKET HEAD SET Gen IV. Premium valve stem seals incl.	KIT PARTE ALTA Gene IV. Paraoli valvole inclusi.
FEL17242		KIT JUNTAS SUPERIOR Gene V & VI exc. H.O. o EFI Juntas tapa válvula de goma. Se incluye retenes de válvula.	GASKET HEAD SET Gen V & VI exc. H.O. or EFI. Molded rubber valve cover & premium valve stem seals incl.	KIT PARTE ALTA Gene V & VI exc. H.O. o EFI.
FEL17280		KIT JUNTAS SUPERIOR Gene V sólo EFI. Se incluye retenes de válvula. Juntas tapa valvula de goma.	GASKET HEAD SET Gen V only EFI. Molded rubber valve cover & premium valve stem seals incl.	KIT PARTE ALTA Gen V solo EFI. Si include paraoli valvole. Paraoli valvole inclusi.
FEL17243		KIT JUNTAS SUPERIOR Gene V sólo H.O. Se incluye retenes de válvula. Juntas tapa valvula de goma.	GASKET HEAD SET Gen V only H.O. Molded rubber valve cover & premium valve stem seals incl.	KIT PARTE ALTA Gen V solo H.O. Paraoli valvole inclusi.

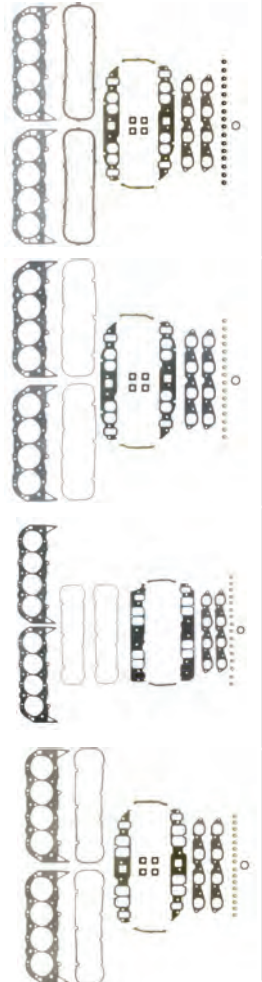

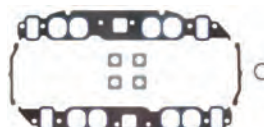
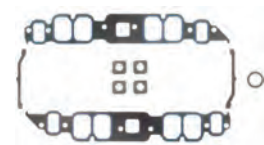
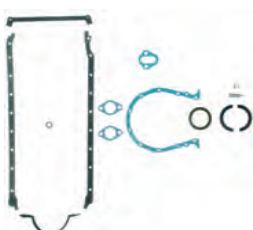
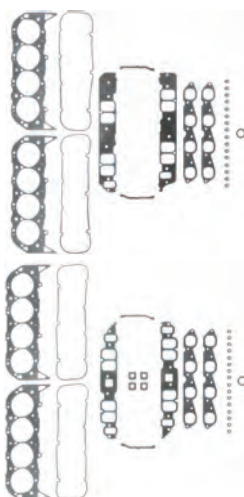

Ref	R.O. OEM	Descripción	Description	Descrizione
FEL17205		KIT JUNTAS SUPERIOR Gene VI sólo EFI. Se incluye retenes de válvula. Juntas tapa valvula de goma.	GASKET HEAD SET Gen VI only EFI Molded rubber valve cover & premium valve stem seals incl.	KIT PARTE ALTA Gen IV solo EFI. Paraoli valvole inclusi.
FEL17201		KIT JUNTAS SUPERIOR Gene VI sólo H.O. Se incluye retenes de válvula. Juntas tapa valvula de goma.	GASKET HEAD SET Gen VI only H.O. Molded rubber valve cover & premium valve stem seals incl.	KIT PARTE ALTA Gen VI solo H.O. Paraoli valvole inclusi.
		<b>INFERIOR</b>	<b>CONVERSION</b>	<b>PARTE BASSA</b>
FEL17140		KIT JUNTAS INFERIOR Gene IV Con retén trasero de 2 piezas y junta cárter de 4 piezas.	CONVERSION GASKET SET Gene IV With 2 pieces rear main bearing seal & 4 pieces oil pan gasket.	KIT PARTE BASSA Gen IV Con paraolio posteriore in 2 pz e guarnizione coppa in 4 pz.
FEL17145		KIT JUNTAS INFERIOR Gene V Con retén trasero de 1 pieza y junta cárter de 1 pieza. Junta cárter de goma y incluida.	CONVERSION GASKET SET Gene V With 1 piece rear main bearing seal & 1 piece oil pan gasket. Molded rubber oil pan gasket. incl.	KIT PARTE BASSA Gen V Con paraolio posteriore di 1 pz e guarnizione coppa in 1 pz.
FEL17146		KIT JUNTAS INFERIOR Gene VI Con retén trasero de 1 pieza y junta cárter de 1 pieza. Junta cárter de goma incluida.	CONVERSION GASKET SET Gene VI With 1 piece rear main bearing seal & 1 piece oil pan gasket. Molded rubber oil pan gasket. incl.	KIT PARTE BASSA Gen VI Con paraolio posteriore in 1 pz, guarnizione coppa in 1 pz.
		<b>COLECTOR ADMISIÓN- ESCAPE</b>	<b>MANIFOLD INTAKE &amp; EXHAUST</b>	<b>ASPIRAZIONE - SCARICO</b>
FEL17341		JUNTA ADMISIÓN Gene IV, V y VI sólo H.O.	INTAKE GASKET Gene IV, V & VI, H.O. only	GUARNIZIONE ASPIRAZIONE Gen IV, V e VI, solo H.O.
FEL17340	856616	JUNTA ADMISIÓN Gene IV	INTAKE GASKET Gene IV	GUARNIZIONE ASPIRAZIONE Gen IV
FEL17340		JUNTA ADMISIÓN Gene V & VI excl. H.O. / EFI	INTAKE GASKET Gene V & VI excl. H.O. / EFI	GUARNIZIONE ASPIRAZIONE Gen V & VI escl. H.O. / EFI
FEL17342	3854095	JUNTA ADMISIÓN Gene V & VI solo EFI	INTAKE GASKET Gene V & VI only EFI	GUARNIZIONE ASPIRAZIONE Gen V & VI solo EFI



Ref	R.O. OEM	Descripción	Description	Descrizione
FEL17440	3852472	KIT JUNTAS ESCAPE Gene IV, V & VI	EXHAUST GASKET KIT Gene IV, V & VI	KIT GUARNIZIONE SCARICO Gene IV, V & VI
		<b>CÁRTER</b>	<b>OIL PAN</b>	<b>COPPA DELL'OLIO</b>
FEL17985	856889	KIT JUNTAS CÁRTER GEN IV 4 piezas	GASKET OIL PAN SET Gene IV 4 pieces gasket	KIT GUARNIZIONE GEN IV, 4 pz
FEL17986	3853510	JUNTA CÁRTER GEN V & VI 1 pieza, incluye junta de goma	GASKET OIL PAN GEN V & VI 1 piece oil pan gasket. Rubber gasket included.	GUARNIZIONE GEN V & VI 1 pz, guarnizione in gomma inclusa.
		<b>RETÉN TRASERO CIGÜENAL</b>	<b>CRANKSHAFT REAR SEAL</b>	<b>PARAOLIO POSTERIORE ALBERO MOTORE</b>
FEL17740		Gen IV Contrarrotación, goma. 2 piezas.	Gene IV Rev. rotation, rubber; 2 pieces.	Gen IV Controrotazione in 2 pz.
		<b>TAPA VÁLVULAS</b>	<b>VALVE COVER</b>	<b>COPERCHIO VALVOLE</b>
FEL17935	856626	KIT JUNTA TAPA VÁLVULAS Gen IV	GASKET SET Gen IV	GUARNIZIONE COPERCHIO PUNTERIE Gen IV
FEL17937	3853513	KIT JUNTA TAPA VÁLVULAS Gen V & VI Juntas de goma.	GASKET SET Gene V & VI Molded rubber gaskets incl.	GUARNIZIONE COPERCHIO PUNTERIE Gen V & VI Kit tenute inclusa.

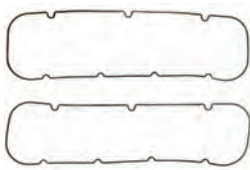

**820 DPX (385 HP GEN. V)**

Ref	R.O. OEM	Descripción	Description	Descrizione
		<b>CULATA</b>	<b>CYLINDER HEAD</b>	<b>TESTATA</b>
FEL17049		JUNTA CULATA Gene IV, V & VI. Se necesitan 2.	CYLINDER HEAD Gene IV, V & VI. 2 required.	GUARNIZIONE TESTATA Gene IV, V & VI. Ne servono 2.
FEL17048	3853587	JUNTA CULATA Gene IV, V & VI Se necesitan 2.	CYLINDER HEAD Gene IV, V & VI. 2 required.	GUARNIZIONE TESTATA Gene IV, V & VI. Ne servono 2.
FEL17249		KIT JUNTAS SUPERIOR Gene V exc. EFI Se incluye retenes de válvula. Juntas tapa valvula de goma.	GASKET HEAD SET Gen V exc. EFI. Molded rubber valve cover & premium valve stem seals incl.	KIT PARTE ALTA Gen V Exc. EFI. Paraoli valvole inclusi.
FEL17281		KIT JUNTAS SUPERIOR Gene V sólo EFI Se incluye retenes de válvula. Juntas tapa valvula de goma.	GASKET HEAD SET Gen V only EFI Molded rubber valve cover & premium valve stem seals incl.	KIT PARTE ALTA Gen V solo EFI. Si include paraoli valvole.

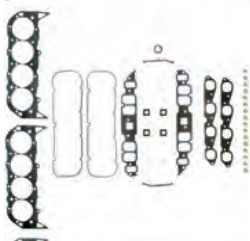
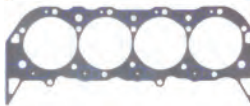
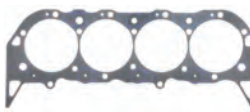

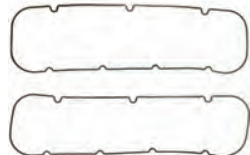
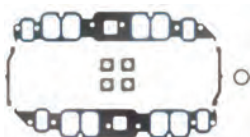
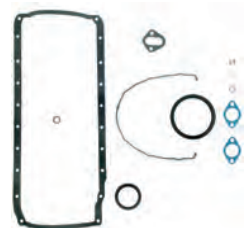
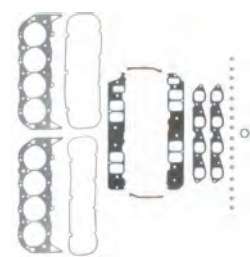

Ref	R.O. OEM	Descripción	Description	Descrizione
FEL17207		KIT JUNTAS SUPERIOR Gene VI sólo EFI. Se incluye retenes de válvula. Juntas tapa valvula de goma.	GASKET HEAD SET Gen VI only EFI. Molded rubber valve cover & premium valve stem seals incl.	KIT PARTE ALTA Gen VI solo EFI Si include paraoli valvole.
		<b>INFERIOR</b>	<b>CONVERSION</b>	<b>PARTE BASSA</b>
FEL17145		KIT JUNTAS INFERIOR Gene V Con retén trasero de 1 pieza y junta cárter de 1 pieza. Junta cárter de goma.	CONVERSION GASKET SET Gene V With 1 piece rear main bearing seal & 1 piece oil pan gasket. Molded rubber oil pan gasket. incl.	KIT PARTE BASSA Gen V Con paraolio posteriore di 1 pz e guarnizione coppa in 1 pz.
FEL17146		KIT JUNTAS INFERIOR Gene VI Con retén trasero de 1 pieza y junta cárter de 1 pieza. Junta cárter de goma.	CONVERSION GASKET SET Gene VI With 1 piece rear main bearing seal & 1 piece oil pan gasket. Molded rubber oil pan gasket. incl.	KIT PARTE BASSA Gen VI Con paraolio posteriore in 1 pz, guarnizione coppa in 1 pz.
		<b>COLECTOR ADMISIÓN- ESCAPE</b>	<b>MANIFOLD INTAKE &amp; EXHAUST</b>	<b>ASPIRAZIONE - SCARICO</b>
FEL17341		JUNTA ADMISIÓN Gene V exc. EFI	INTAKE GASKET Gene V & exc. EFI	GUARNIZIONE ASPIRAZIONE Gen V ecc. EFI
FEL17342		JUNTA ADMISIÓN Gene V & VI sólo EFI	INTAKE GASKET Gene V & VI only EFI	GUARNIZIONE ASPIRAZIONE Gene V & VI solo EFI
FEL17440	3852472	KIT JUNTAS ESCAPE Gene IV, V & VI	EXHAUST GASKET KIT Gene IV, V & VI	KIT GUARNIZIONE SCARICO Gene IV, V & VI
		<b>CÁRTER</b>	<b>OIL PAN</b>	<b>COPPA DELL'OLIO</b>
FEL17986	3853510	JUNTA CÁRTER GEN V & VI 1 pieza, junta de goma.	GASKET OIL PAN GEN V & VI 1 piece oil pan gasket, rubber gasket.	GUARNIZIONE GEN V & VI 1 pz. guarnizione in gomma
		<b>RETÉN TRASERO CIGÜEÑAL</b>	<b>CRANKSHAFT REAR SEAL</b>	<b>PARAOLIO POSTERIORE ALBERO MOTORE</b>
FEL17740		Gen IV Contrarrotación; 2 piezas.	Gene IV Rev. rotation; 2 pieces.	Gen IV Controrotazione in 2 pz.
		<b>TAPA VÁLVULAS</b>	<b>VALVE COVER</b>	<b>COPERCHIO VALVOLE</b>
FEL17935	856626	KIT JUNTA TAPA VÁLVULAS Gen IV	GASKET SET Gen IV	GUARNIZIONE COPERCHIO PUNTERIE Gen IV
FEL17937	3853513	KIT JUNTA TAPA VÁLVULAS Gen V sólo EFI & VI	GASKET SET Gene V EFI only & VI	GUARNIZIONE COPERCHIO PUNTERIE Gen V solo EFI & VI

# JUNTAS MOTORES GASOLINA GAS ENGINES GASKET GUARNIZIONE MOTORI BENZINA (BASE VOLVO)



## JUNTAS CULATA CYLINDER HEAD GASKET GUARNIZIONI TESTATA



Ref.	R.O. OEM	INCLUIDA EN EL KIT INCLUDED IN THE KIT INCLUSO NEL KIT
REC1378645	31378645 463412	REC876300

### MOTORES / ENGINES / MOTORI

AQ120B, 125A, 140A  
B21  
BB140A



Ref.	R.O. OEM	INCLUIDA EN EL KIT INCLUDED IN THE KIT INCLUSO NEL KIT
REC1378646	1378646 1326785 1332644	REC876301 REC876302 REC876303

### MOTORES / ENGINES / MOTORI

AQ125B  
AQ131A, B, C, D  
AQ145A, B  
AQ151A, B, C  
AQ171A, C  
230A, B  
250A, B  
251A



Ref.	R.O. OEM	GRUESO THICKNESS SPESSORE
REC419310	419310 419763	0,8 mm

### MOTORES / ENGINES / MOTORI

AQ115A  
AQ130A, C,  
MB20B, B 20  
Agujeros ovalados  
Oval holes  
Fori ovali



Ref.	R.O. OEM	GRUESO THICKNESS SPESSORE
REC857621	857621 876783 875543 419628	2,0 mm

### MOTORES / ENGINES / MOTORI

AQ115A  
AQ30B,  
MB20A, B 20  
Agujeros redondo  
Round holes  
Fori rotondi



Ref.	R.O. OEM	GRUESO THICKNESS SPESSORE	INCLUIDA EN EL KIT INCLUDED IN THE KIT INCLUSO NEL KIT
REC9139282	9139282 462623	1,2 mm	REC876358

### MOTORES / ENGINES / MOTORI

AQ115B  
AQ130D  
MB20, C, B 20  
Agujeros ovalados  
Oval holes  
Fori ovali



Ref.	R.O. OEM	GRUESO THICKNESS SPESSORE	INCLUIDA EN EL KIT INCLUDED IN THE KIT INCLUSO NEL KIT
REC9139284	913928 3855409 461056 430107 461618	0,8 mm	REC876359

### MOTORES / ENGINES / MOTORI

AQ165  
AQ170A, B, C, B 30  
Agujeros ovalados  
Oval holes  
Fori ovali



## KIT JUNTAS SUPERIOR GASKET HEAD SETS KIT GUARNIZIONI PARTE ALTA



Ref.	R.O. OEM	GRUESO THICKNESS SPESSORE
REC876356	876356	0,8 mm

### MOTORES / ENGINES / MOTORI

AQ115A  
AQ130A, C  
MB20B  
Agujeros ovalados  
Oval holes  
Fori ovali

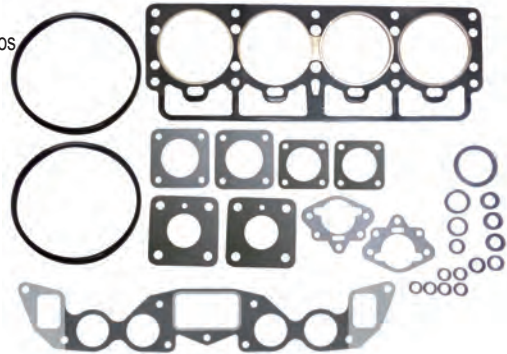

Ref.	R.O. OEM	GRUESO THICKNESS SPESSORE
REC876358	876358 875569	1,2 mm

### MOTORES / ENGINES / MOTORI

AQ115B  
AQ130D  
MB20C  
BB115C  
Agujeros ovalados  
Oval holes  
Fori ovali

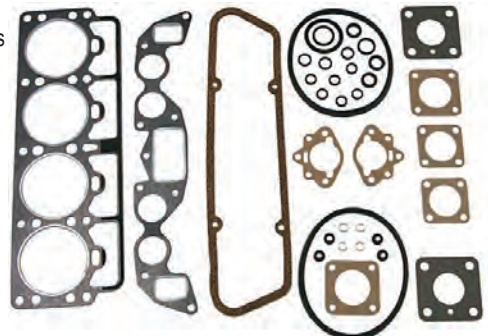

Ref.	R.O. OEM
REC876359	876359 875570

**MOTORES / ENGINES / MOTORI**  
AQ170C  
BB170C

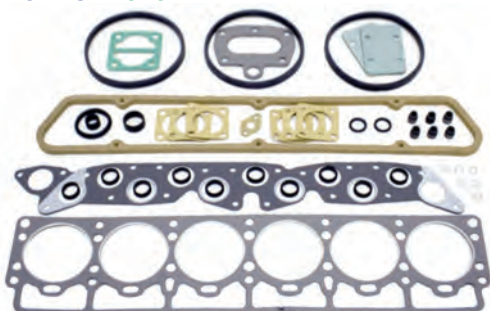

Ref.	R.O. OEM
REC876337	876337 876335 875402 875533

**MOTORES / ENGINES / MOTORI**  
AQ165A  
AQ170A, B  
BB165A  
BB170A, B

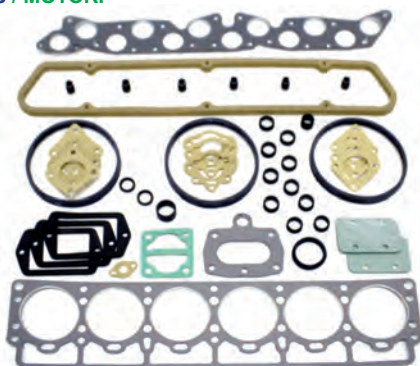

Ref.	R.O. OEM
REC876300	876300 875587

**MOTORES / ENGINES / MOTORI**  
AQ120B, 125A, 140A  
BB140A

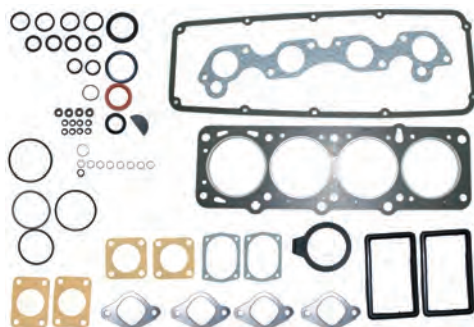

Ref.	R.O. OEM
REC876302	876302 876022

**MOTORES / ENGINES / MOTORI**  
AQ125B  
AQ131A, B, C, D  
AQ145B  
AQ151A, B, C  
230A, B  
250A, B

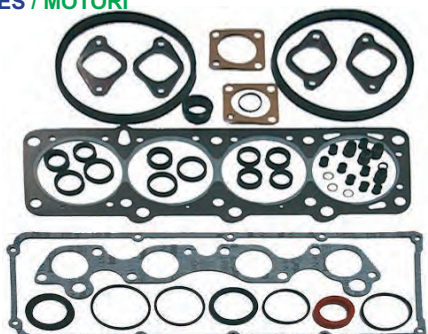

Ref.	R.O. OEM
REC876301	876301 875678

**MOTORES / ENGINES / MOTORI**  
AQ145A  
BB145A



Ref.	R.O. OEM
REC876303	876303 876071

**MOTORES / ENGINES / MOTORI**  
AQ171A, C  
251A

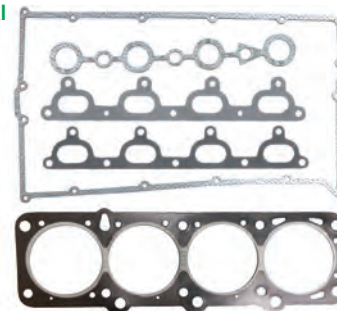

**JUNTAS TAPA BALANCRINES**  
**VALVE COVER GASKET**  
**GUARNIZIONI COPERCHIO**  
**PUNTERIE**



Ref.	R.O. OEM
REC419678	419678

**MOTORES / ENGINES / MOTORI**  
AQ60F, 90, 95, 95A, 110, 120  
AQ115A, B  
AQ130A, B, C, D  
MB20A, B, C



Ref.	R.O. OEM
REC430039	430039

**MOTORES / ENGINES / MOTORI**  
AQ165A  
AQ170A, B, C  
BB165A  
BB170A, B, C



Ref.	R.O. OEM
REC1378909	1378909

**MOTORES / ENGINES / MOTORI**  
AQ120B, 125A, 140, 145A  
BB140A, 145A





Ref.	R.O. OEM
REC1378870	1378870 1336753

**MOTORES / ENGINES / MOTORI**

AQ125B  
AQ131A, B, C, D  
AQ145B  
AQ151A, B, C  
230A, B  
250A, B

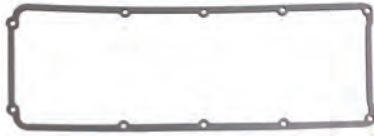

Ref.	R.O. OEM
REC1378853	1378853

**MOTORES / ENGINES / MOTORI**

AQ171A, C  
251A

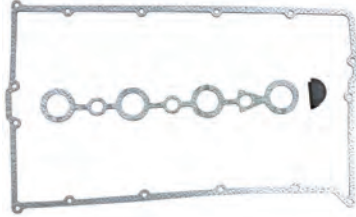

**JUNTAS DE ADMISIÓN  
INTAKE GASKET  
GUARNIZIONE DI ASPIRAZIONE**



Ref.	R.O. OEM
REC1378879	1378879 1266796 463225

**MOTORES / ENGINES / MOTORI**

AQ120B  
AQ125A, B  
AQ131A, B, C, D  
AQ140A  
BB140  
AQ145A, B  
AQ151A, B, C  
230A  
250A



Ref.	R.O. OEM
REC1378854	1378854

**MOTORES / ENGINES / MOTORI**

AQ171A, C  
251A



**JUNTAS ADMISIÓN Y ESCAPE  
INTAKE & EXHAUST GASKET  
GUARNIZIONE  
DI SCARICO E ASPIRAZIONE**



Ref.	R.O. OEM
REC1378913	1378913 461092

**MOTORES / ENGINES / MOTORI**

AQ165A  
AQ170A, B, C  
BB170C



**JUNTAS DE ESCAPE  
EXHAUST GASKET  
GUARNIZIONE SCARICO  
(BASE VOLVO)**



**COLECTOR DE ESCAPE A CULATA  
EXHAUST MANIFOLD TO CYLINDER HEAD  
COLLETTORE DI SCARICO**

Ref.	R.O. OEM	PARA COLECTORES FOR MANIFOLDS PER COLLETTORI
REC856044	856044 824633	HGE4532

**MOTORES / ENGINES / MOTORI**

AQ115A, B  
AQ130A, B, C, D  
BB115A, B, C



Ref.	R.O. OEM
REC855513	855513

**MOTORES / ENGINES / MOTORI**

AQ171A, C  
251A



Ref.	R.O. OEM
REC855967	855967

**MOTORES / ENGINES / MOTORI**

230A, B  
250A, B  
AQ120, 125, 131, 140, 145, 151



Ref.	R.O. OEM
REC1378911	1378911 418870

**MOTORES / ENGINES / MOTORI**

AQ60F, 90, 95, 95A, 100, 105A, 110, 120  
BB30, 10  
MB18  
MB20A, B, C



**JUNTAS CÁRTER  
OIL PAN GASKET  
GUARNIZIONI COPPA  
DELL'OLIO**



Ref.	R.O. OEM
REC1378864	1378864 463587 418262

**MOTORES / ENGINES / MOTORI**

AQ60F, 90, 95, 95A, 105, 110  
AQ115A, B, C  
AQ120, B  
AQ125A, B  
AQ130A, B, C, D  
AQ131A, B, C, D  
AQ140A  
AQ145A, B  
AQ151A, B, C  
AQ171A, C  
230A, B  
250A, B  
251A  
MB18  
MB20A, B, C



Ref.	R.O. OEM
REC1378914	1378914 461113

**MOTORES / ENGINES / MOTORI**

AQ165A, B  
AQ170A, B, C  
BB165A  
BB170A, B, C



**KIT JUNTAS INFERIOR  
CONVERSION GASKET SETS  
KIT GUARNIZIONI PARTE  
BASSA**



Ref.	R.O. OEM
REC876342	876342 875400

**MOTORES / ENGINES / MOTORI**

AQ60F, 90, 95, 95A, 105, 110, 120  
AQ115A, B  
AQ130A, B, C, D  
MB20A, B, C

Incluye juntas para B18, 20  
Includes B18, 20 mod. gaskets  
Include le guarnizione per B18, 20

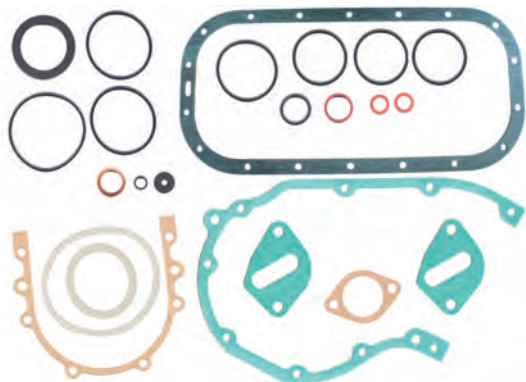

Ref.	R.O. OEM
REC876306	876306 875403

**MOTORES / ENGINES / MOTORI**

AQ165A  
AQ170A, B, C  
BB165A  
BB170A, B, C

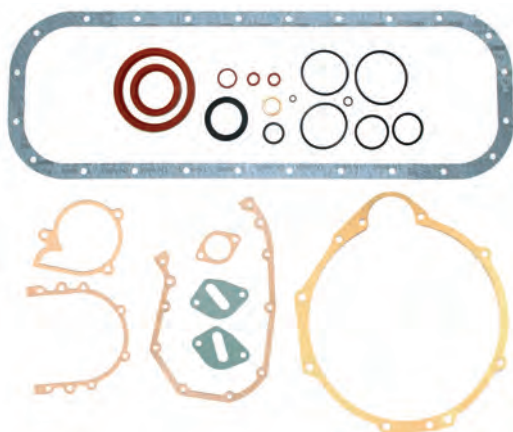

Ref.	R.O. OEM
REC876393	876393 876433 875588

**MOTORES / ENGINES / MOTORI**

AQ120B  
AQ125A  
AQ140A  
AQ145A  
BB140A  
BB145A



Ref.	R.O. OEM
REC876448	876448 876023

**MOTORES / ENGINES / MOTORI**

AQ125B  
AQ145B

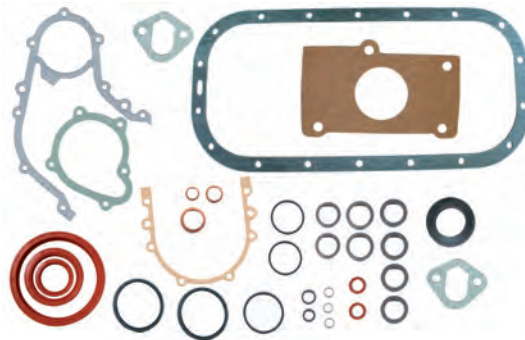

Ref.	R.O. OEM
REC876304	876304 876072

**MOTORES / ENGINES / MOTORI**

AQ131A, B, C, D  
AQ151A, B, C  
171A, C  
230A, B  
250A, B  
251A

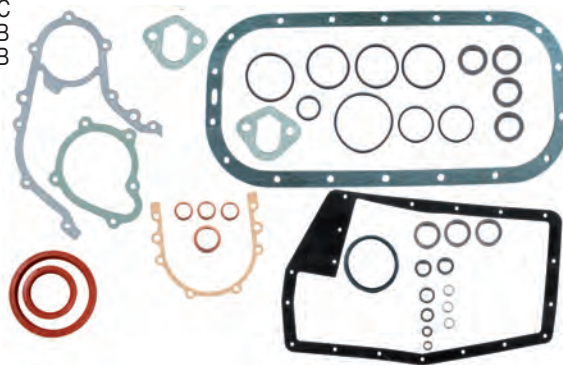

**SILICONA JUNTAS  
LIQUID GASKET  
SILICONE PER  
GUARNIZIONE**

STA82910



# JUNTAS MOTORES DIESEL DIESEL ENGINES GASKET GUARNIZIONE MOTORI DIESEL



## JUNTAS CULATA CYLINDER HEAD GASKET GUARNIZIONI TESTATA



Ref.	R.O. OEM	Ø	INCLUIDA EN EL KIT INCLUDED IN THE KIT INCLUSO NEL KIT
REC859151	859151 833070	89 mm	REC876377

MOTORES / ENGINES / MOTORI  
MD1B, 2B, 3B  
AQD2B



Ref.	R.O. OEM	INCLUIDA EN EL KIT INCLUDED IN THE KIT INCLUSO NEL KIT
REC840569	840569	REC876307

MOTORES / ENGINES / MOTORI  
2001 AG, B, BG

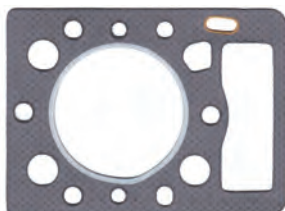

Ref.	R.O. OEM	INCLUIDA EN EL KIT INCLUDED IN THE KIT INCLUSO NEL KIT
REC859137	859137 833453	REC876376 REC876380

MOTORES / ENGINES / MOTORI  
MD11C, D  
MD17C, D

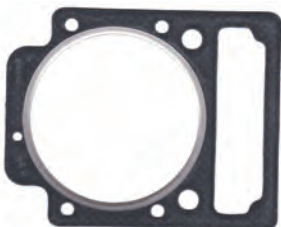

Ref.	R.O. OEM	Ø
REC833274	833274	79 mm

MOTORES / ENGINES / MOTORI  
D1A, 2A  
AQD2A  
MD1, 1A, 2, 2A

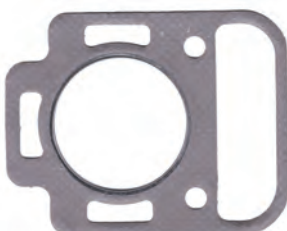

Ref.	R.O. OEM	INCLUIDA EN EL KIT INCLUDED IN THE KIT INCLUSO NEL KIT
REC859134	859134 838127	REC876341

MOTORES / ENGINES / MOTORI  
MD5A, B, C



Ref.	R.O. OEM	INCLUIDA EN EL KIT INCLUDED IN THE KIT INCLUSO NEL KIT
REC859094	859094 840328	REC876308

MOTORES / ENGINES / MOTORI  
2002 AG, B, BG, D

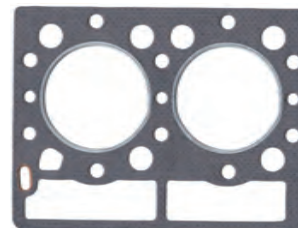

Ref.	R.O. OEM	GRUESO THICKNESS SPESSORE	INCLUIDA EN EL KIT INCLUDED IN THE KIT INCLUSO NEL KIT
REC3809167	3809167 859136 840270 860749	0,8 mm	REC876431

MOTORES / ENGINES / MOTORI  
MD7A, B MO 35145+

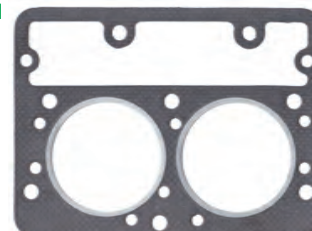

Ref.	R.O. OEM	INCLUIDA EN EL KIT INCLUDED IN THE KIT INCLUSO NEL KIT
REC859135	859135 3875376	REC876379

MOTORES / ENGINES / MOTORI  
MD6A, B

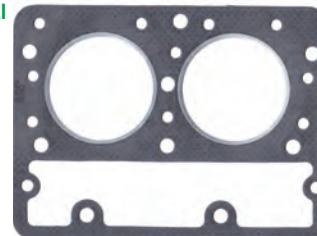

Ref.	R.O. OEM	GRUESO THICKNESS SPESSORE	INCLUIDA EN EL KIT INCLUDED IN THE KIT INCLUSO NEL KIT
REC3809167	859136	1.3 mm	REC876431

MOTORES / ENGINES / MOTORI  
MD7A MO -35144

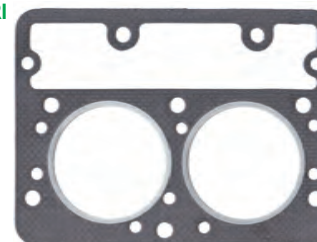

Ref.	R.O. OEM	GRUESO THICKNESS SPESSORE
REC3808602	3808602	1.2 mm
REC3809647	3809647	1.3 mm

MOTORES / ENGINES / MOTORI  
D1-13, B, F



Ref.	R.O. OEM	INCLUIDA EN EL KIT INCLUDED IN THE KIT INCLUSO NEL KIT
REC859093	859093 840405	REC876310

**MOTORES / ENGINES / MOTORI**  
2003, AG, B, BG, D, T, TB

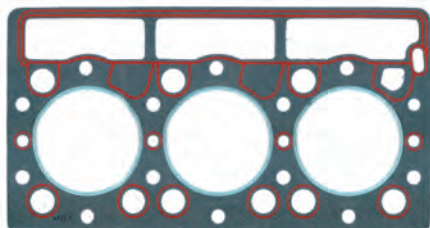

Ref.	R.O. OEM	INCLUIDA EN EL KIT INCLUDED IN THE KIT INCLUSO NEL KIT
REC3580309	3580309	REC21760

**MOTORES / ENGINES / MOTORI**  
MD2030A, B, C, D

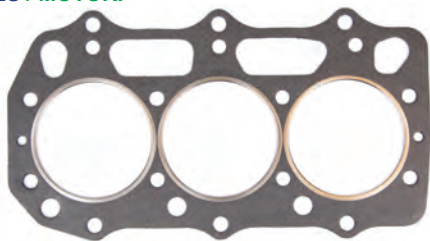

Ref.	R.O. OEM	INCLUIDA EN EL KIT INCLUDED IN THE KIT INCLUSO NEL KIT
REC3584202	3584202 3580482	REC21761

**MOTORES / ENGINES / MOTORI**  
2040  
MD2040A, B, C, D



Ref.	R.O. OEM	GRUESO THICKNESS SPESSORE
REC3812109	3812109	1.2 mm
REC3886431	3886431	1.3 mm

**MOTORES / ENGINES / MOTORI**  
D1-20A, B, F

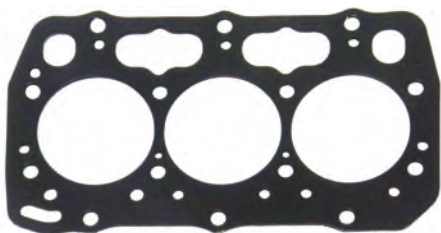

Ref.	R.O. OEM	GRUESO THICKNESS SPESSORE
REC3840842	3840842	1.3 mm
REC3812199	3812199	1.2 mm

**MOTORES / ENGINES / MOTORI**  
D1-30A, B, F

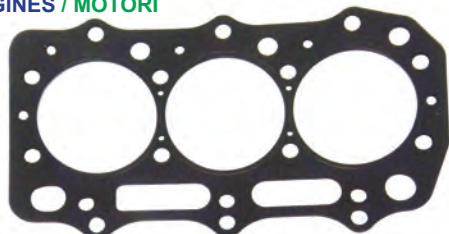

Ref.	R.O. OEM	GRUESO THICKNESS SPESSORE
REC21192973	21192973 3840843	1.2 mm
REC21192974	21192974 3889517	1.3 mm

**MOTORES / ENGINES / MOTORI**  
D2-40A, B, F



Ref.	R.O. OEM	INCLUIDA EN EL KIT INCLUDED IN THE KIT INCLUSO NEL KIT
REC859647	859647	REC21762 REC21763 REC21764 REC21765

**MOTORES / ENGINES / MOTORI**  
MD22A, L-A, L-B, P-B  
TAMD22P-B  
TMD22A, B



Ref.	R.O. OEM	INCLUIDA EN EL KIT INCLUDED IN THE KIT INCLUSO NEL KIT
REC3582432	3582432 858993 838628	REC3582435

**MOTORES / ENGINES / MOTORI**  
D31  
KAD32 P-A, P



Ref.	R.O. OEM	INCLUIDA EN EL KIT INCLUDED IN THE KIT INCLUSO NEL KIT
REC859150	859150 1544109	REC3582597

**MOTORES / ENGINES / MOTORI**

AD30A  
AQAD30A  
MD30A  
TAMD30A  
TD30A  
TMD30A



Ref.	R.O. OEM	GRUESO THICKNESS SPESSORE	INCLUIDA EN EL KIT INCLUDED IN THE KIT INCLUSO NEL KIT
REC859152	859152 829531 829214	1.6 mm	REC876417

**MOTORES / ENGINES / MOTORI**

MD21A, B  
AQD21A, B



Ref.	R.O. OEM	INCLUIDA EN EL KIT INCLUDED IN THE KIT INCLUSO NEL KIT
RM21228429	21228429	REC3589322

**MOTORES / ENGINES / MOTORI**  
D2-55A, B, C, E  
D2-75A, B, C  
D2-50F



Ref.	R.O. OEM
REC21165389	21165389 3581868

**MOTORES / ENGINES / MOTORI**  
D4



Ref.	R.O. OEM	GRUESO THICKNESS SPESSORE	1 AGUJERO 1 HOLE 1 BUCO	CLASE CLASS CLASSE
REC30731261	30731261	1.02 mm	1	A
REC30731262	30731262	1.07 mm	2	B
REC30731263	30731263	1.12 mm	3	C
REC30731264	30731264	1.17 mm	4	D
REC30650525	30650525	1.27 mm	5	E

**MOTORES / ENGINES / MOTORI**  
D3-110I-A, I-B, I-C  
D3-130A-A, I-A, A-B, I-B, A-C, I-C  
D3-160A-A, I-A, A-B, I-B, A-C, I-C,  
D3-190A-B, I-B, A-C, I-C.



Ref.	R.O. OEM	INCLUIDA EN EL KIT INCLUDED IN THE KIT INCLUSO NEL KIT
REC3583786	3583786	REC3583787 REC3583788
	3582433	
	3580742	
	858992	
	876853	

**MOTORES / ENGINES / MOTORI**  
41  
KAD42A  
KAMD42A  
D43, 44, 300

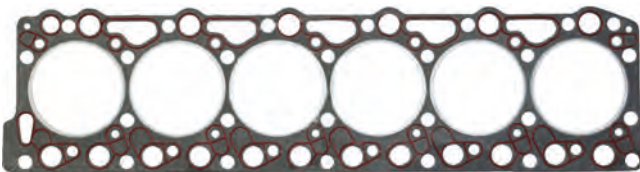

Ref.	R.O. OEM	INCLUIDA EN EL KIT INCLUDED IN THE KIT INCLUSO NEL KIT
REC21165390	21165390 3581869	REC21371111

**MOTORES / ENGINES / MOTORI**  
D6



Ref.	R.O. OEM	INCLUIDA EN EL KIT INCLUDED IN THE KIT INCLUSO NEL KIT
REC859155	859155 858503	REC3582596

**MOTORES / ENGINES / MOTORI**  
40A, B, C

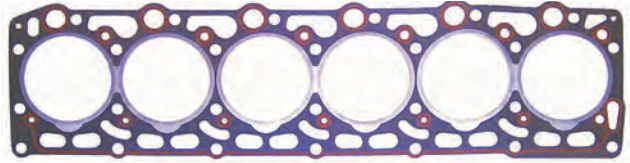

**KIT JUNTAS SUPERIOR  
DECARB. GASKET SETS  
KIT GUARNIZIONI PARTE ALTA**



Ref.	R.O. OEM
REC876377	876377
	875500
	875502
	875504
	876374
	876375

**MOTORES / ENGINES / MOTORI**  
MD1B, MD2B (Se necesitan 2 kits / 2 kits required / 2 kit ne servono)  
MD3B (Se necesitan 3 kits / 3 kits required / 3 kit ne servono)

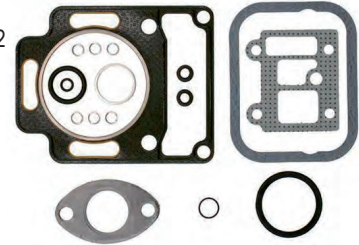

Ref.	R.O. OEM
REC876341	876341 875561

**MOTORES / ENGINES / MOTORI**  
MD5A, B, C



Ref.	R.O. OEM
REC876307	876307

**MOTORES / ENGINES / MOTORI**  
2001, AG, B, BG

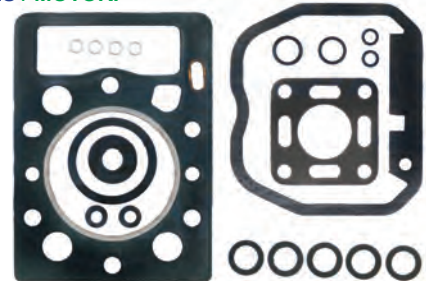

Ref.	R.O. OEM
REC876308	876308

**MOTORES / ENGINES / MOTORI**  
2002, AG, B, BG, D

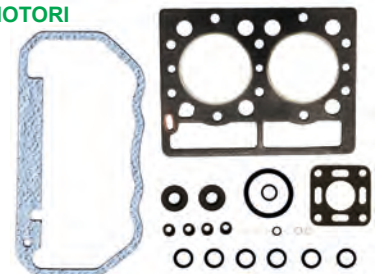

Ref.	R.O. OEM
REC876376	876376 875553

**MOTORES / ENGINES / MOTORI**

MD11C, D

No incluye kit de gomas:

Kit seals not included:

Non include kit dei paraolio:

REC875550

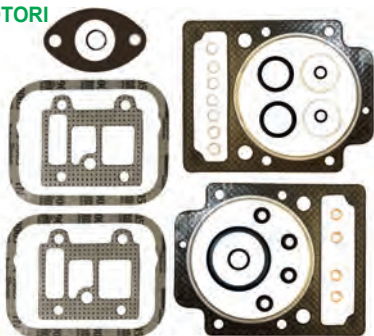

Ref.	R.O. OEM
REC876380	876380 875572

**MOTORES / ENGINES / MOTORI**

MD17C, D

No incluye kit de gomas:

Kit seals not included:

Non include kit dei paraolio:

REC875550

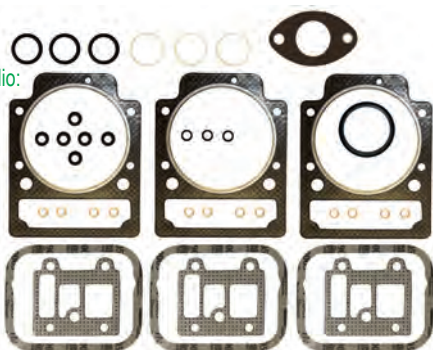

Ref.	R.O. OEM
REC876379	876379 875508

**MOTORES / ENGINES / MOTORI**

MD6A, B

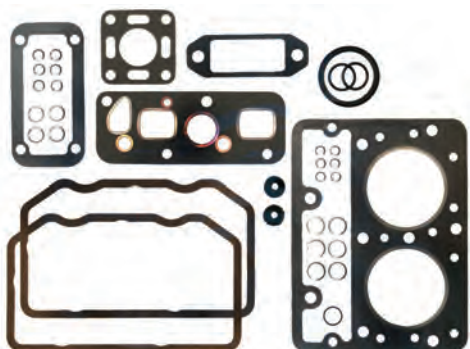

Ref.	R.O. OEM	GRUESO THICKNESS SPESSORE
REC876431	876430 876431	1.3 mm

**MOTORES / ENGINES / MOTORI**

MD7A

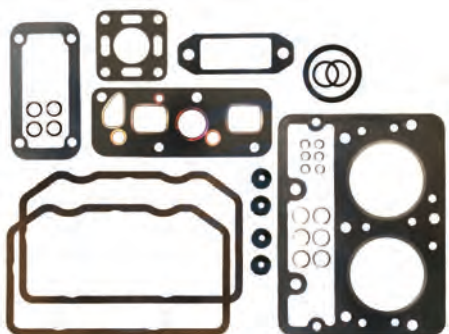

Ref.	R.O. OEM
REC876310	876310

**MOTORES / ENGINES / MOTORI**

2003, D, T, TB, AG, B, BG

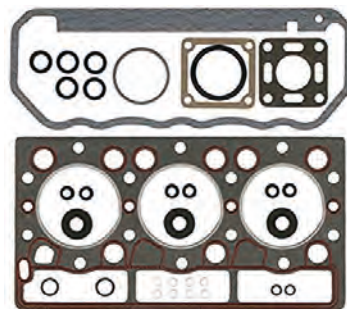

Ref.	R.O. OEM
REC21760	

**MOTORES / ENGINES / MOTORI**

2030A, B, C, D



Ref.	R.O. OEM
REC21761	

**MOTORES / ENGINES / MOTORI**

2040A, B, C, D

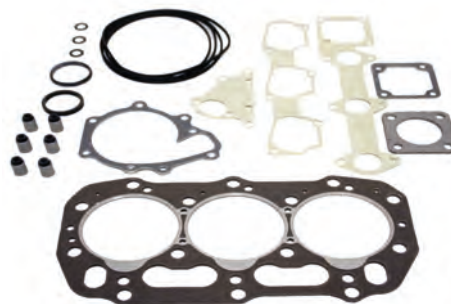

Ref.	R.O. OEM
REC3589322	3589322

**MOTORES / ENGINES / MOTORI**

D2-50F

D2-55A, B, C, D, E, F

D2-75A, B, C

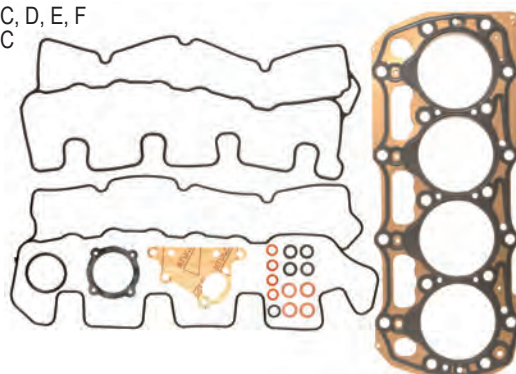

Ref.	R.O. OEM
REC21371112	21371112 3588432

**MOTORES / ENGINES / MOTORI**  
D-4

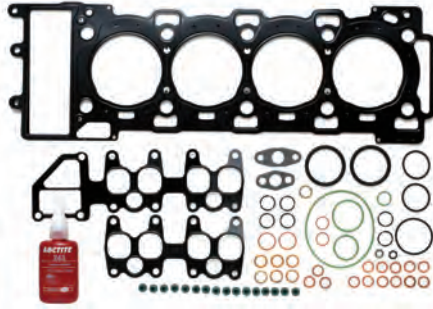

Ref.	R.O. OEM
REC876417	876417 875388 875567

**MOTORES / ENGINES / MOTORI**  
AQD21A, B  
MD21A, B

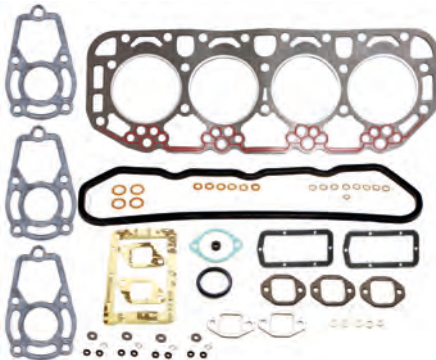

Ref.	R.O. OEM
REC3582597	3582597 876453 875031

**MOTORES / ENGINES / MOTORI**  
MD30A  
AD30A  
TD30A  
TMD30A  
AQAD30A  
TAMD30A

Junta de turbo no versión de acero  
Gasket turbo not steel version  
Guarnizione turbo non in acciaio



Ref.	R.O. OEM
REC3582435	3582435 876103 876121 3582434

**MOTORES / ENGINES / MOTORI**  
MD31A,  
TMD31A, L-A  
AQAD31A  
TAMD31A, B, P-A, L-A,  
M-A  
AD31B, P-A, L-A  
KAD32P, P-A

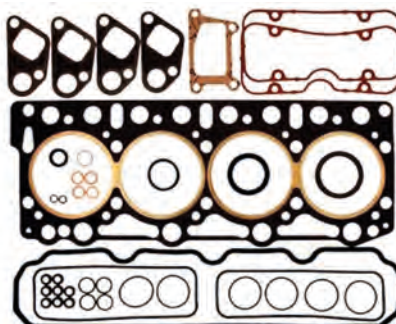

Ref.	R.O. OEM
REC21762	

**MOTORES / ENGINES / MOTORI**  
MD22A, L-A

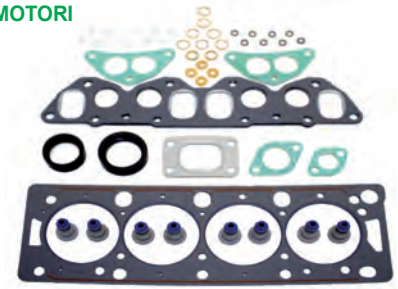

Ref.	R.O. OEM
REC21763	

**MOTORES / ENGINES / MOTORI**  
MD22L-B, P-B

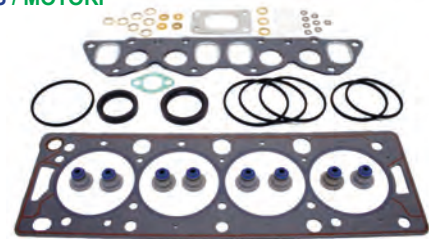

Ref.	R.O. OEM
REC21764	

**MOTORES / ENGINES / MOTORI**  
TMD22A

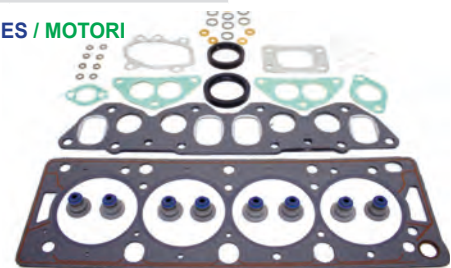

Ref.	R.O. OEM
REC21765	

**MOTORES / ENGINES / MOTORI**  
TAMD22P-B, P-C  
TMD22B



Ref.	R.O. OEM
REC3582596	3582596 876395 875633 875662

**MOTORES / ENGINES / MOTORI**  
MD40A  
TMD40A, B, C  
AQAD40A  
AQAD40A, B  
TAMD40A, B

Junta de turbo no versión de  
acero  
Gasket turbo not steel version  
Guarnizione turbo non in  
acciaio

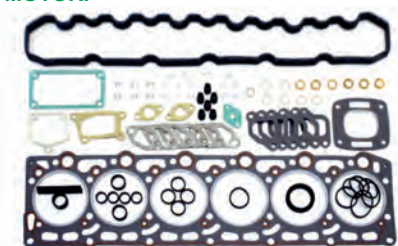

Ref.	R.O. OEM
REC3583787	3583787
	3582436
	876104
	876530

**MOTORES / ENGINES / MOTORI**

- AQAD41A
- AQD41A
- D41B, L-A
- KAD42A
- KAD43P-A
- KAMD42A
- KAMD43P-A, P-B
- TAMD41A, B, P-A, L-A, M-A, H-A
- TMD41A, B, L-A

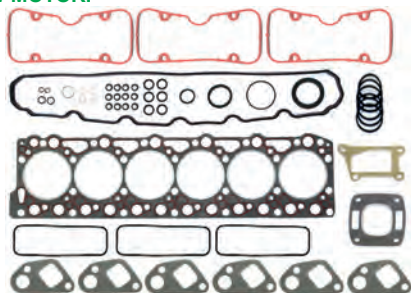

Ref.	R.O. OEM
REC876416	876416
	875438

**MOTORES / ENGINES / MOTORI**

- AQD32A
- MD32A

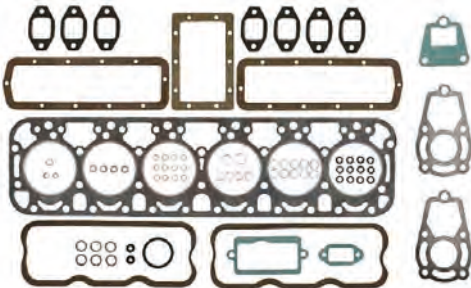

Ref.	R.O. OEM
REC21371111	21371111
	3588433

**MOTORES / ENGINES / MOTORI**

- D-6

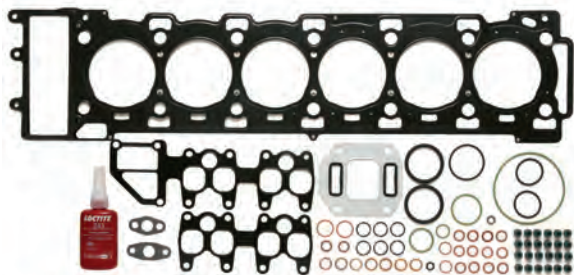

Ref.	R.O. OEM
REC3583788	3583788
	3582437

**NEW**

**MOTORES / ENGINES / MOTORI**

- D44, 300
- KAD44P-A, P-B, P-C
- KAMD44P-A, P-C
- KAD300-A
- KAMD300-A

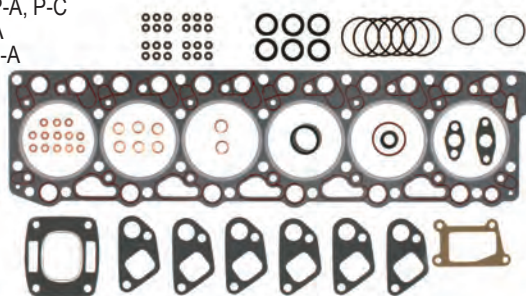

Ref.	R.O. OEM
REC3883845	3883845
	3589554

**MOTORES / ENGINES / MOTORI**

- D3-110I-A
- D3-130A-A, I-A
- D3-160A-A, I-A

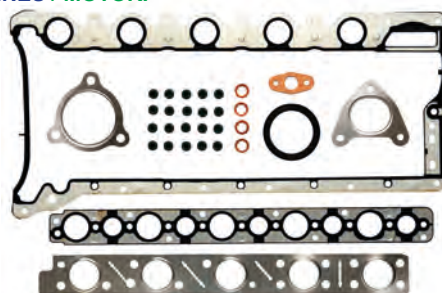

Completa el kit con la junta de culata  
Completed the kit with cylinder head gasket  
Completa il kit con la guarnizione della testata



Ref.	R.O. OEM
REC121153	

**NEW**

**MOTORES / ENGINES / MOTORI**

- D3-110I-D, I-E
- D3-140A-D, A-E, I-E
- D3-150I-D, I-E
- D3-170A-D, A-E, I-D, I-E
- D3-200A-D, A-E, I-D, I-E
- D3-220A-D, A-E, I-D, I-E

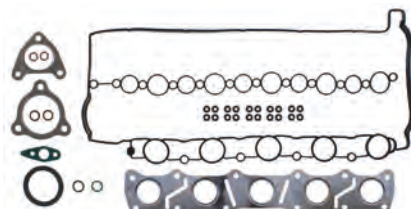

Completa el kit con la junta de culata  
Completed the kit with cylinder head gasket  
Completa il kit con la guarnizione della testata



Ref.	R.O. OEM
REC121154	

**NEW**

**MOTORES / ENGINES / MOTORI**

- D3-110I-F, I-G
- D3-140A-F, A-G, I-F, I-G
- D3-150I-F, I-G
- D3-170A-F, A-G, I-F, I-G
- D3-200A-F, A-G, I-F, I-G
- D3-220A-F, A-G, I-F, I-G

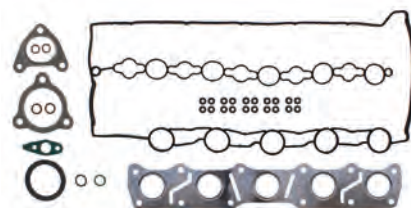

Completa el kit con la junta de culata  
Completed the kit with cylinder head gasket  
Completa il kit con la guarnizione della testata



Ref.	R.O. OEM
REC121152	

**NEW**

**MOTORES / ENGINES / MOTORI**

- D3-110I-B, I-C
- D3-130A-B, A-C, I-B, I-C
- D3-160A-B, A-C, I-B, I-C
- D3-190A-B, A-C, I-B, I-C

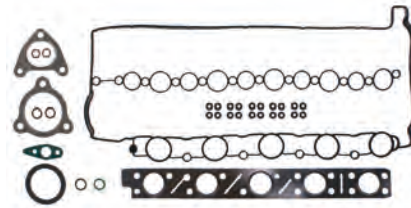

Completa el kit con la junta de culata  
Completed the kit with cylinder head gasket  
Completa il kit con la guarnizione della testata





**JUNTAS TAPA BALANCINES  
VALVE COVER GASKET  
GUARNIZIONI COPERCHIO  
PUNTERIE**



Ref.	R.O. OEM
REC859120	859120 802399

**MOTORES / ENGINES / MOTORI**  
MD1A, B MD11C, D  
MD2A, B MD17C, D  
MD3B



Ref.	R.O. OEM
REC838066	838066

**MOTORES / ENGINES / MOTORI**  
MD5A, B, C



Ref.	R.O. OEM
REC840115	840115 3875384

**MOTORES / ENGINES / MOTORI**  
MD6A, B, MD7A (necesita 2 piezas / 2  
pcs. required / Ne servono 2 pz)  
MD7B (necesita 1 pieza / 1 pc. required  
/ Ne servono 1 pz)



Ref.	R.O. OEM
REC859042	859042 840572

**MOTORES / ENGINES / MOTORI**  
2001, AG, B, BG



Ref.	R.O. OEM
REC859043	859043 840440

**MOTORES / ENGINES / MOTORI**  
2002 AG, B, BG, D



Ref.	R.O. OEM
REC859044	859044 840461

**MOTORES / ENGINES / MOTORI**  
2003 AG, B, BG, D, T, TB



Ref.	R.O. OEM
REC30713459	30713459

**MOTORES / ENGINES / MOTORI**  
D3 -B, -C, -D, -E

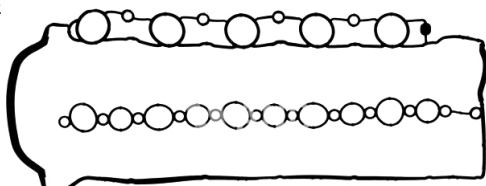

Ref.	R.O. OEM
REC31430317	31430317 30777600



**MOTORES / ENGINES / MOTORI**  
D3, -G, -F

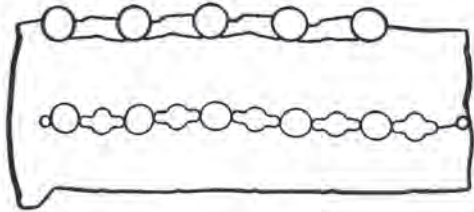

Ref.	R.O. OEM
REC838652	838652

**MOTORES / ENGINES / MOTORI**  
31, 32

AD31A, B, L-A, P-A  
AQAD31A  
MD31A  
TAMD31A, B  
TAMD31L-A, M-A, P-A  
TMD31A, B, L-A  
KAD32P-A



Ref.	R.O. OEM
RM1542287	1542287

**MOTORES / ENGINES / MOTORI**

AD40B  
AQAD40A, B  
AQD40A  
MD40A  
TAMD40A, B  
TMD40A, B, C



Ref.	R.O. OEM
REC838653	838653

**MOTORES / ENGINES / MOTORI**

D41  
KAD42A, B, P-A  
KAMD42A, B, P-A  
KAD43P-A



Ref.	R.O. OEM
REC1544119	1544119

**MOTORES / ENGINES / MOTORI**

AD30A  
AQAD30A  
MD30A  
TAMD30A  
TMD30A



Ref.	R.O. OEM
REC8642665	8642665
REC8692438	8692438



**MOTORES / ENGINES / MOTORI**  
D3-110 --> D3-190



REC8642665

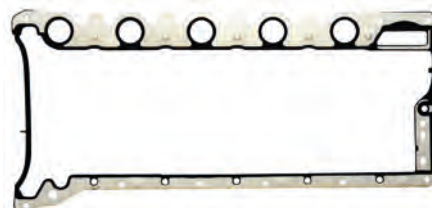

REC8692438

Ref.	R.O. OEM
REC3812131	3812131

**MOTORES / ENGINES / MOTORI**  
D1-20, B, F



**NEW**

Ref.	R.O. OEM
REC3809657	3809657

**MOTORES / ENGINES / MOTORI**  
D1-13, B, F



**NEW**

Ref.	R.O. OEM
REC3884548	3884548

**MOTORES / ENGINES / MOTORI**  
D1-30, B, F



**NEW**

Ref.	R.O. OEM
REC838654	838654

**MOTORES / ENGINES / MOTORI**  
31, 32 (Se necesitan 2 piezas / 2 pc. required / Ne servono 2 pz)  
41, 42, 43 (Se necesitan 3 piezas / 3 pc. required / Ne servono 3 pz)  
KAD42A  
KAMD42A



**JUNTA SUPERIOR  
UPPER GASKET  
GUARNIZIONE SUPERIORE**

Ref.	R.O. OEM
REC889486	889486

**MOTORES / ENGINES / MOTORI**  
D2-55, B, C, D, E, F  
D2-60F  
D2-75, B, C

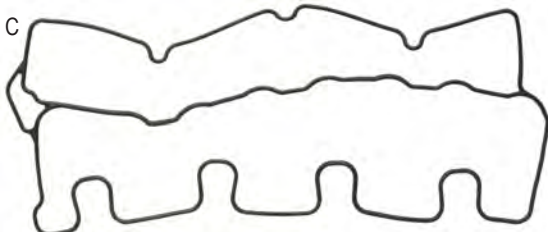

**NEW**

**JUNTA INFERIOR  
DOWN GASKET  
GUARNIZIONE INFERIORE**

Ref.	R.O. OEM
REC3583546	3583546

**MOTORES / ENGINES / MOTORI**  
D2-55, B, C, D, E, F  
D2-60F  
D2-75, B, C, F

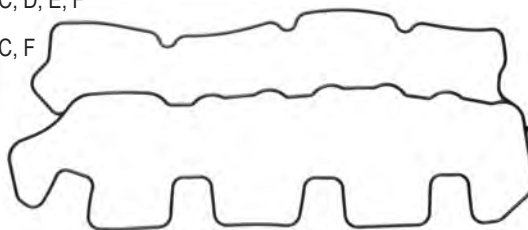

**NEW**

**RETÉN TAPA LATERAL BLOQUE  
SEAL SIDE COVER BLOCK  
GUARNIZIONE COPERCHIO  
LATERALE BLOCCO**



Ref.	R.O. OEM
REC1542052	1542052

**MOTORES / ENGINES / MOTORI**  
30, 31, 32, 40, 41, 42, 43, 44, 300



**NEW**

**JUNTAS COLECTOR Y CODOS  
DE ESCAPE  
EXHAUST MANIFOLD  
& ELBOW GASKET  
GUARNIZIONE COLLETTORE  
E GOMITO DI SCARICO**



Ref.	R.O. OEM
REC3583336	3583336

**MOTORES / ENGINES / MOTORI**  
D4 (necesita 1 pieza / 1 pc. required / Ne servono 1 pz)  
D6 (necesita 2 piezas / 2 pc. required / Ne servono 2 pz)



Ref.	R.O. OEM
REC3582725	3582725

**MOTORES / ENGINES / MOTORI**  
D4, 6 (necesita 2 piezas / 2 pc. required / Ne servono 2 pz)



Ref.	R.O. OEM
REC859145	859145 833598 897322

**MOTORES / ENGINES / MOTORI**  
MD1A, B  
MD2A, B  
MD3B  
MD11C, D  
MD17C, D



Ref.	R.O. OEM
REC859140	859140 819720 819723

**MOTORES / ENGINES / MOTORI**  
MD19, 27, 29, 32A  
MD21A, B  
AQD19, 27, 29A, 32A  
AQD21A, B

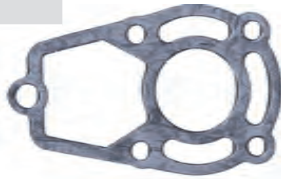

Ref.	R.O. OEM
REC859015	859015 803374

**MOTORES / ENGINES / MOTORI**  
MB10A  
MD1A, B  
MD2A, B  
MD3B  
MD5A, B, C



Ref.	R.O. OEM
REC840902	840902 3875050

**MOTORES / ENGINES / MOTORI**  
MD6A, B  
MD7A, B  
2001, 2002, 2003 AG, B, BG, D, T, TB



Ref.	R.O. OEM
REC859107	859107

**MOTORES / ENGINES / MOTORI**  
MD1A, B  
MD2A, B  
MD3B  
MD5A, B, C



Ref.	R.O. OEM
REC1542123	1542123 1542177

**MOTORES / ENGINES / MOTORI**  
30 (necesita 4 piezas / 4 pc. required / Ne servono 4 pz)  
40 (necesita 6 piezas / 6 pc. required / Ne servono 6 pz)



Ref.	R.O. OEM
REC876144	876144

**MOTORES / ENGINES / MOTORI**  
31, 32 (necesita 4 piezas / 4 pc. required / Ne servono 4 pz)  
41, 42, 43, 44, 300 (necesita 6 piezas / 6 pc. required / Ne servono 6 pz)



Ref.	R.O. OEM
RM859834	859834

**MOTORES / ENGINES / MOTORI**  
MD22A, L-A, L-B, P-B  
TMD22A, B  
TAMD22P-B  
TAMD315-A  
D2-50F  
D2-55A, B, C, D, E, F



Ref.	R.O. OEM
REC30729340	30729340

**MOTORES / ENGINES / MOTORI**  
D3



Ref.	R.O. OEM
REC22119	

**MOTORES / ENGINES / MOTORI**  
MD30A,  
TMD30A,  
AQAD30A, T  
AMD30A



Ref.	R.O. OEM
REC22120	

**MOTORES / ENGINES / MOTORI**  
MD40A  
AQAD40A, B  
AMD40A, B

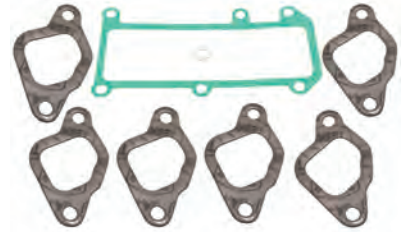

Ref.	R.O. OEM
REC22121	

**MOTORES / ENGINES / MOTORI**  
AD40B  
AQAD40A  
TMD40A, B, C



**COLECTOR - CULATA  
MANIFOLD - HEAD  
COLLETORE - TESTATA**

Ref.	R.O. OEM
REC859194	859194 3875382

**MOTORES / ENGINES / MOTORI**  
MD6A, B  
MD7A, B

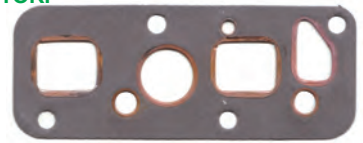

**KIT JUNTAS TURBO  
TURBO GASKET SET  
KIT GUARNIZIONE TURBINE**



Ref.	R.O. OEM
REC3582595	3582595 876398

**MOTORES / ENGINES / MOTORI**  
TMD30A  
TMD40A, B, C  
TAMD30A  
TAMD40A, B  
AQD40A  
AQAD30A  
AQAD40A, B  
AD30A

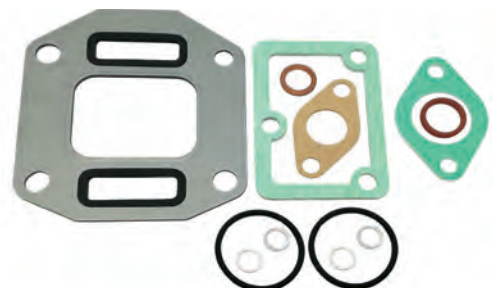

Ref.	R.O. OEM
REC22134	

**MOTORES / ENGINES / MOTORI**  
MD30A, 31A, 40A



Ref.	R.O. OEM
RM3588435	3588435

**MOTORES / ENGINES / MOTORI**  
D4, 6

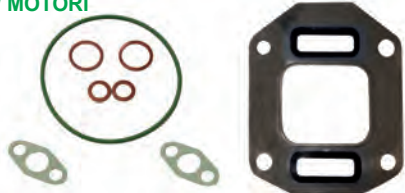

Ref.	R.O. OEM
REC3582563	3582563 876312 876108

**MOTORES / ENGINES / MOTORI**

AQD41A  
AQAD31A, 41A  
TMD31A, B, L-A,  
TMD41A, B, L-A  
TAMD31A, B, P-A, L-A, M-A,  
TAMD41A, B, L-A, M-A, H-A  
AD31P-A, L-A  
AD41B, L-A,  
D31B  
D41B, L-A  
D42, 43, 44, 300



Ref.	R.O. OEM
REC22034	

**MOTORES / ENGINES / MOTORI**  
2003T, TB

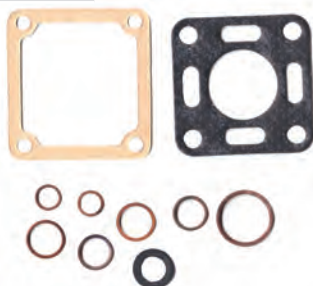

Ref.	R.O. OEM
RM3883844	3883844 1275549 + 21584008

**MOTORES / ENGINES / MOTORI**  
D3



**JUNTAS TAPA TRASERA  
CIGÜEÑAL  
REAR CRANKSHAFT COVER  
GASKET  
GUAR. CARTER POSTERIORE  
ALBERO MOTORE**



Ref.	R.O. OEM
REC829487	829487

**MOTORES / ENGINES / MOTORI**  
D30, 31, 40, 41, 43, 44, 300  
KAD / KAMD 42



**JUNTAS TAPA DISTRIBUCIÓN  
TIMING COVER GASKET  
GUARNIZIONE CARTER  
DISTRIBUZIONE**



Ref.	R.O. OEM
REC859039	859039 1542219

**MOTORES / ENGINES / MOTORI**  
D30, 31, 40, 41, 43, 44, 300  
KAD / KAMD 42



Ref.	R.O. OEM
REC859038	859038 842990

**MOTORES / ENGINES / MOTORI**  
D30, 31, 40, 41, 43, 44, 300  
KAD / KAMD 42



**JUNTAS CÁRTER  
OIL PAN GASKET  
GUARNIZIONI COPPA  
DELL'OLIO**



Ref.	R.O. OEM
REC861822	861822

**MOTORES / ENGINES / MOTORI**  
MD2010A, B, C, D  
D1-13A, B, F



**NEW**

Ref.	R.O. OEM
REC3580227	3580227

**MOTORES / ENGINES / MOTORI**  
MD2020A, B, C, D  
D1-20A, B, F



**NEW**

Ref.	R.O. OEM
REC21849843	21849843

**MOTORES / ENGINES / MOTORI**  
MD2030A, B, C, D  
D1-30A, B, F



**NEW**

Ref.	R.O. OEM
REC3840859	3840859

**MOTORES / ENGINES / MOTORI**  
D2-40A, B, F



**NEW**

Ref.	R.O. OEM
REC840648	840648 818035

**MOTORES / ENGINES / MOTORI**  
MD21A, B  
MD19  
AQD19  
AQD21A, B

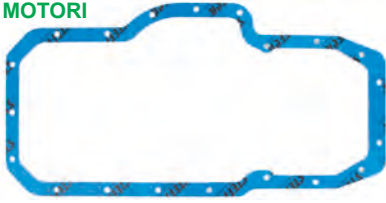

Ref.	R.O. OEM	INCLUIDA EN EL KIT INCLUDED IN THE KIT INCLUSO NEL KIT
REC861251	861251 860685 1542247 859032	REC876349 REC876774

**MOTORES / ENGINES / MOTORI**  
40, 41,  
KAD42A  
KAMD42A  
D43, 44, 300



Ref.	R.O. OEM	INCLUIDA EN EL KIT INCLUDED IN THE KIT INCLUSO NEL KIT
REC861250	861250 860684 1544124	REC876427 REC876361

**MOTORES / ENGINES / MOTORI**  
30, 31  
KAD32P, P-A

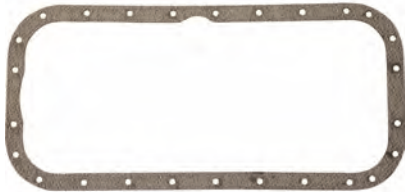

Ref.	R.O. OEM	INCLUIDA EN EL KIT INCLUDED IN THE KIT INCLUSO NEL KIT
REC861603	861603 859726	REC21766

**MOTORES / ENGINES / MOTORI**  
D22  
MD22A, L-A, L-B, P-B  
TAMD22P-B  
TMD22A, B



**KIT JUNTAS INFERIOR  
CONVERSION GASKET SETS  
KIT GUARNIZIONI INFERIORI**



Ref.	R.O. OEM
REC876378	876378 875501

**MOTORES / ENGINES / MOTORI**  
MD1B

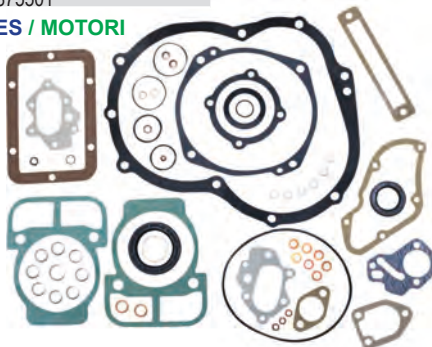

Ref.	R.O. OEM
REC876389	876389 875503

**MOTORES / ENGINES / MOTORI**  
MD2B  
AQD2B

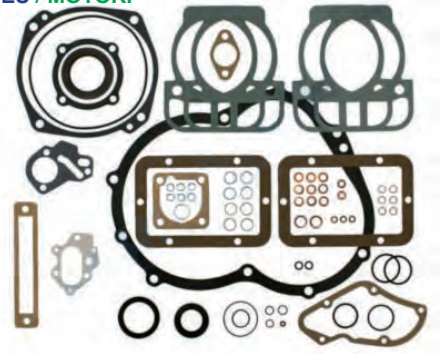

Ref.	R.O. OEM
REC876388	876388 875505

**MOTORES / ENGINES / MOTORI**  
MD3B



Ref.	R.O. OEM
REC876381	876381 875562

**MOTORES / ENGINES / MOTORI**  
MD5A, B



Ref.	R.O. OEM
REC876382	876382 875715

**MOTORES / ENGINES / MOTORI**  
MD5C

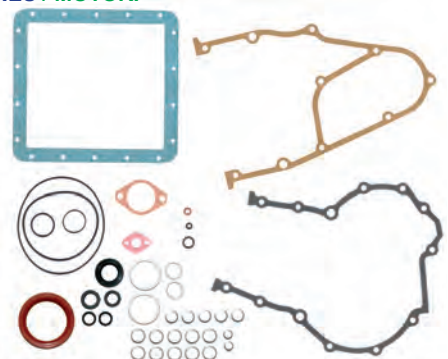

Ref.	R.O. OEM
REC876314	876314 875509

**MOTORES / ENGINES / MOTORI**  
MD6A, B  
MD7A, B

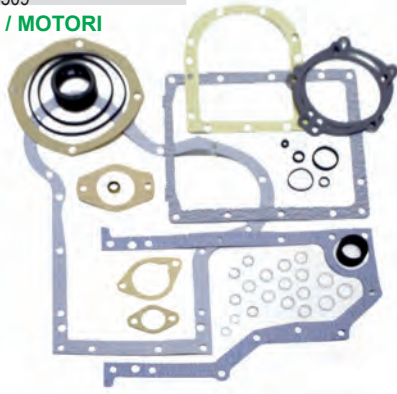

Ref.	R.O. OEM
REC876384	876384 875554

**MOTORES / ENGINES / MOTORI**  
MD11C, D



Ref.	R.O. OEM
REC876383	876383 875573

**MOTORES / ENGINES / MOTORI**  
MD17C, D

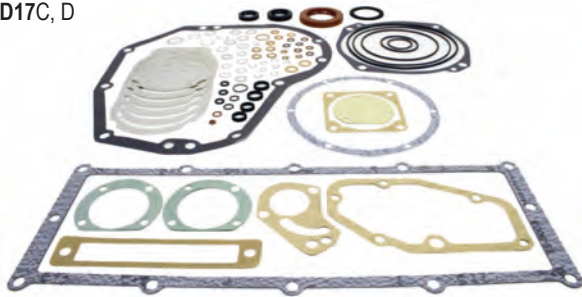

Ref.	R.O. OEM
REC875757	875757

**MOTORES / ENGINES / MOTORI**  
2001, AG, B, BG  
2002, AG, B, BG, D  
2003, AG, B, BG, D

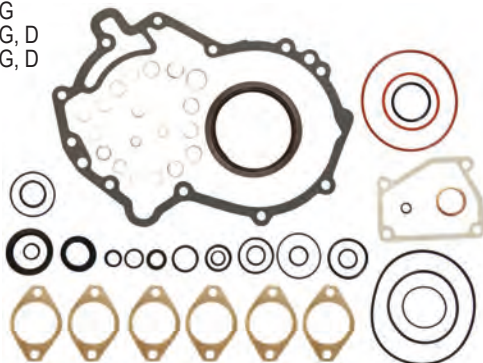

Ref.	R.O. OEM
REC876054	876054

**MOTORES / ENGINES / MOTORI**  
2003T, TB



Ref.	R.O. OEM
REC877419	877419

**MOTORES / ENGINES / MOTORI**  
D2-55A, B, C, D, E  
D2-75A, B, C  
D2-50F

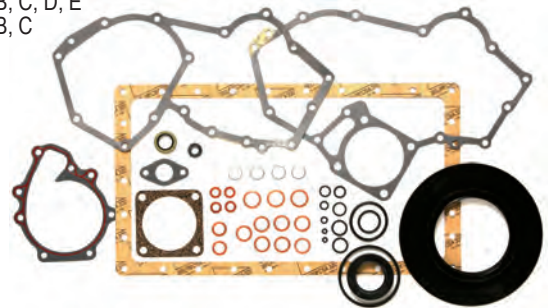

Ref.	R.O. OEM
REC3588434	3588434

**MOTORES / ENGINES / MOTORI**  
D4, 6



Ref.	R.O. OEM
REC875439	875439

**MOTORES / ENGINES / MOTORI**  
MD32A  
AQD32A

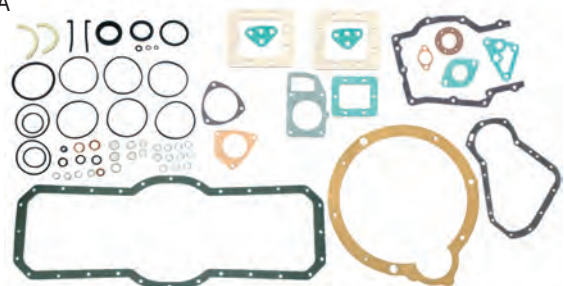

Ref.	R.O. OEM
REC876655	876655



**MOTORES / ENGINES / MOTORI**  
MD2030A, B, C, D

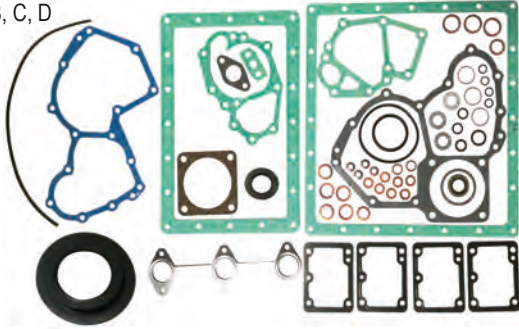

Ref.	R.O. OEM
REC876427	876427 876032

**MOTORES / ENGINES / MOTORI**  
MD30A  
AD30A  
TMD30A  
AQAD30A  
TAMD30A



Ref.	R.O. OEM
REC876361	876361 876105

**MOTORES / ENGINES / MOTORI**  
MD31A  
TMD31A, L-A  
AQAD31A  
TAMD31A, B, P-A,  
L-A, M-A

AD31B, P-A, L-A  
KAD32P, P-A



Ref.	R.O. OEM
REC876349	876349 875634

**MOTORES / ENGINES / MOTORI**  
MD40A  
AD40B  
TMD40A, B, C  
AQD40A  
AQAD40A, B  
TAMD40A, B



Ref.	R.O. OEM
REC876774	876774 876362 876106 876531

**MOTORES / ENGINES / MOTORI**  
TMD41A, B, L-A  
TAMD41A, B, P-A, L-A, M-A, H-A  
AQAD41A  
AQD41A  
D41B, L-A  
KAD42A  
KAMD42A  
D43, 44, 300

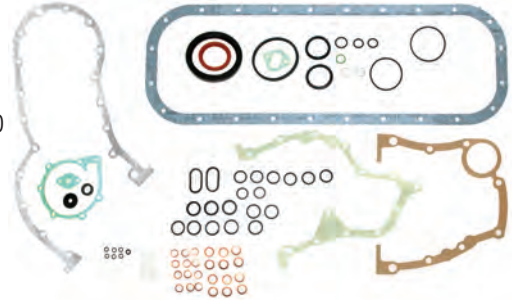

Ref.	R.O. OEM
REC875387	875387 875421

**MOTORES / ENGINES / MOTORI**  
MD21A, B  
AQD19  
MD19  
AQD21A, B



Ref.	R.O. OEM
REC21766	

**MOTORES / ENGINES / MOTORI**  
D22A  
MD22L-A, L-B, P-B  
TAMD22P-B  
TMD22A, B, P-C

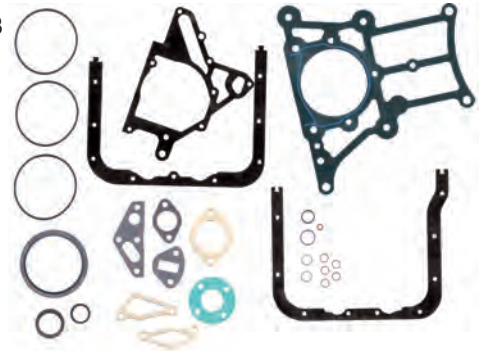

**SILICONA JUNTAS  
LIQUID GASKET  
SILICONE PER  
GUARNIZIONE**

STA82910



# RETENES CIGÜEÑAL CRANKSHAFT SEALS PARA OLIO ALBERO MOTORE

MOTORES ENGINES MOTORI			DELANTERO FRONT SEAL ANTERIORE	R.O. OEM		TRASERO REAR SEAL POSTERIORE	R.O. OEM	
AQ120B AQ125A, B AQ131A, B, C, D AQ140A BB140A AQ145A, B	BB145A AQ151A, B, C AQ165A BB165A AQ170A, B, C BB170A, B, C	AQ171A, C 230A, B 250A, B 251A	REC1276425	1276425		REC6842160	6842160	
MD1B, 2B AQD2B MD11C, D			REC803356	3588879				
2001, B, AG, BG 2002, B, D, AG, BG 2003, B, D, T, AG, BG, TB, -SOLAS, B-SOLAS, TB-SOLAS			REC6842273	6842273		REC40005775	40005775	
AD30A AQAD30A MD30A TAMD30A TMD30A MD31A AQAD31A AD31A, B, D-A, L-A, P-A, XD TAMD31A, B, D, L-A, M-A, P-A, S-A TMD31A, B, D, L-A KAD32P-A	AQAD40A, B AQD40A TMD40A, B, C TAMD40A, B MD40A AD41A, B, D, L-A, P-A D41A, B, D, L-A AQAD41A TAMD41A, B, D, H-A, H-B, P-A, L-A, M-A TMD41A, B, D, L-A KAD42A, B, P-A KAMD42A, B, P-A	TAMD42B, WJ-A KAD43P-A KAMD43P-A KAD44P-A, P-B, P-C KAMD44P-A, P-C KAD300-A KAMD300-A	REC1542318	1542318		REC860971	3582851	
D2-50F D2-55A, B, C, D, E, F D2-60F D2-75A, B, C, F		<b>NEW</b>	REC3580586	3580586		REC3583700	3583700	
MD2040A, B, C, D		<b>NEW</b>	REC3580586	3580586		REC861823	861823	
D3-110, 130, 140, 150, 160, 170, 190, 200, 220		<b>NEW</b>	REC31339213	31339213		REC31339213	31339213	
MD2010A, B, C, D MD2020A, B, C, D MD2030A, B, C, D D1-13A, B, F D1-20A, B, F D1-30A, B D2-40A, B, F		<b>NEW</b>	REC3580026	3580026		REC861823	861823	
D4 D6		<b>NEW</b>	REC3582748	3582748		REC3586960	3586960	



# PISTONES PISTONS PISTONI

## KITS PISTONES PISTONS SETS KIT PISTONI (BASE VOLVO)



Ref.	R.O. OEM	BULÓN PIN SPINOTTO	
REC272002	272002	22 mm	STD
REC272004	272004	22 mm	.030

### MOTORES / ENGINES / MOTORI

- AQ115A, B
- AQ105A
- AQ130A, B, C, D,
- AQ165A
- AQ170A, B, C
- BB115A, B, C
- BB165A
- BB170A, B, C
- MB10A
- MB20A, B, C



Ref.	R.O. OEM	BULÓN PIN SPINOTTO	
REC272059	272059	24 mm	.030

### MOTORES / ENGINES / MOTORI

- AQ105A
- AQ115A, B
- AQ130A, B, C, D,
- AQ165A
- AQ170A, B, C
- BB115A, B, C,
- BB165A
- BB170A, B, C
- MB10A
- MB20A, B, C,



Ref.	R.O. OEM	ARO RING ANELLO	
REC272040	272040	1.75 x 2.0 x 4.0 mm	STD
REC272043	272043	1.75 x 2.0 x 4.0 mm	1.00 mm

### MOTORES / ENGINES / MOTORI

- AQ120B
- AQ125A
- AQ140A
- BB140A



Motors GM y FORD  
GM & FORD Engines  
Motori base GM e FORD



## KITS PISTONES PISTONS SETS KIT PISTONI



Ref.	R.O. OEM	
REC875551	875551	STD
REC875579	875579	0.75 mm

### MOTORES / ENGINES / MOTORI

- MD1B, 2B, 3B, AQD2B,
- MD11C, 11D, 17C, 17D



Ref.	R.O. OEM	
REC21921545	21921545	STD



### MOTORES / ENGINES / MOTORI

- D4-180I-B, C, D, E, F
- D4-210A-A, B
- D4-210I-A, B
- D4-225A-B, C, D, E, F
- D4-225I-B, C, D, E, F
- D4-260A-A, B, C, D, E, F
- D4-260D-B, C, D, E, F
- D4-260I-A, B, C, D, E, F
- D6-280A-A, B, C, D, E
- D6-280I-A, B, C, D, E
- D6-300A-F, F (MC)
- D6-300I-F
- D6-310A-A, B, C, D, E
- D6-310D-B, C
- D6-310I-A, B, C, D, E
- D6-330A-B, C, D, E, F
- D6-330D-B, C, D, E, F
- D6-330I-B, C, D, E, F
- D6-350A-A, B
- D6-370A-B, C, D, E, F
- D6-370D-B, C, D, E, F
- D6-370I-A, B, C, D, E, F



Ref.	R.O. OEM	
REC22915955	22915955	STD



### MOTORES / ENGINES / MOTORI

- D4-300A-A, C, D, E, F
- D4-300D-A, C, D, E, F
- D4-300I-A, C, D, E, F
- D6-400A-E, F
- D6-435D-A, C, D, E, F
- D6-435I-A, C, D, E
- D6-435I-SC-F
- D6-435I-TC-F
- D6-435I-WJ-F



## KITS GOMAS CAMISAS GASKET KITS FOR CYLINDER LINER KIT GOMMINI CAMICIA



Ref.	R.O. OEM	Motors Engines Motori	Pieces necesarias pcs required peze necessita
REC875550	875550	MD11C, D	2
		MD17C, D	3



Ref.	R.O. OEM	Motors Engines Motori	Pieces necesarias pcs required peze necessita
REC275751	275751	MD30, 31	4
	875651		
	275595	MD40, 41, 42, 43, 44, 300	6

### MOTORES / ENGINES / MOTORI

- AQAD30A
- AD31A, B, L-A, P-A, D-A, XD
- AD41A, B, D, L-A, P-A
- AQAD31A
- AQAD40A
- AQAD41A
- D41A, B, D, L-A
- KAD300-A
- KAD42A, B, P-A
- KAD43P-A
- KAD44P-A, P-B, P-C
- KAMD300-A
- KAMD42A, B, P-A
- KAMD43P-A
- KAMD44P-A, P-C
- MD30A
- MD31A
- MD40A
- TAMD30A
- TAMD31A, B, D, L-A,
- M-A, P-A, S-A
- TAMD40A, B
- TAMD41A, B, D, H-A,
- H-B, P-A, L-A, M-A
- TAMD42B
- TAMD42WJ-A
- TD30A
- TD31ACE
- TD40A
- TMD30A
- TMD31A, B, D, L-A
- TMD40A, B, C
- TMD41A, B, D, L-A



**KITS CAMISAS**  
(PISTÓN, PIN Y AROS)  
**CYLINDER LINER KITS**  
(PISTON, PIN & RINGS)  
**KIT CAMICIA**  
(SPINOTTO, PISTONE E FASCE)







MOTORES ENGINES MOTORI	REF	R.O. OEM	
AQAD30A AQAD40A, B MD30A MD40A TAMD30A TAMD40A, B TD30A TD40A TMD30A TMD40A, B, C	REC875722	875722 275052 875652 875707	
AD31A AD41A AQAD31A AQAD41A D41A TAMD31A TAMD41A TMD31A TMD41A	REC876099	876099 867975 838660	
AD31B, D-A, XD AD41B, D D41B, D TAMD31B, D TAMD41B, D TMD31B, D TMD41B, D	<b>NEW</b> REC22389354	22389354 876834 876819 876784 876261	
KAD42A, B KAMD42A, B TAMD42B	<b>NEW</b> REC22185019	22185019 877071 876527	
AD31L-A, P-A AD41L-A, P-A D41L-A KAD32P-A KAD42P-A KAD43P-A KAMD42P-A KAMD43P-A TAMD31L-A, M-A, TAMD31P-A, S-A TAMD41H-A, H-B, P-A TAMD41L-A, M-A TAMD42WJ-A TMD31L-A TMD41L-A	<b>NEW</b> REC22185027	22185027 3817034 3581714 876851	
KAD44P-A, P-B, P-C KAD300-A KAMD300-A KAMD44P-A, P-C	<b>NEW</b> REC3817861	3817861 3586722	
TAMD72A, P-A, WJ-A TAMD73P-A, WJ-A	REC876548	876548 876611	

MOTORES ENGINES MOTORI	REF	R.O. OEM	
AQD70B, BL, CL MD70B, BK, C TAMD70B, C THAMD70B, C TMD70B, C	REC875541	875541 875320 875655	
TD70CHC, CRC TMD70C	REC875676	875676	

**KITS AROS DE PISTONES**  
**PISTONS RINGS SETS**  
**KIT FASCE PISTONI**



MOTORES ENGINES MOTORI	REF	R.O. OEM	MEDIDA (mm) SIZE (mm) MISURA (mm)		
AQ105, 115, 130, MB 20 (B20), 165A, 170A	REC275334	275334	2.0 x 2.0 x 4.7	STD	
	REC275336	275336	2.0 x 2.0 x 4.7	030	
AQ115, 130 (B20), 170B, 170C	REC275344	275344	1.75 x 2.0 x 4.0	STD	
	REC275346	275346	1.75 x 2.0 x 4.0	030	
	REC275340	275340	1.75 x 2.0 x 4.0	STD	
AQ120B, 125A, 140A	REC275341	275341	1.75 x 2.0 x 4.0	020	
	REC275342	275342	1.75 x 2.0 x 4.0	040	

MOTORES ENGINES MOTORI	REF	R.O. OEM	MEDIDA (mm) SIZE (mm) MISURA (mm)		
AQ120B, 125A, 140A	REC275337	275337	2.0 x 2.0 x 4.0	STD	
	REC275338	275338	2.0 x 2.0 x 4.0	050	
AQ145A	REC275331	275331	1.75 x 2.0 x 4.0	STD	
AQ125B AQ145B AQ131A, B, C, D AQ151A, B, C AQ171A, C, AQ230A, 250A, 251A	REC275369	275369	1.75 x 1.75 x 3.5 mm	STD	
	REC275370	275370	1.75 x 1.75 x 3.5 mm	030	

Motores GM y FORD  
GM & FORD Engines  
Motori base GM e FORD

















**INSTALACIÓN  
AROS DE PISTÓN  
RING & PISTON  
COMPRESSOR  
ATTREZZO FASCE  
E PISTONI**  
SSP4206



**KITS AROS DE PISTONES  
PISTONS RINGS SETS  
KIT FASCE PISTONI**



MOTORES ENGINES MOTORI	REF	R.O. OEM		
MD1B, 2B, 3B AQD2B MD11C, D MD17C, D	REC875498	875498	STD	
	REC875499	875499	030	
2001, A, B, AG, BG 2002, B, D, AG, BG 2003, B, D, AG, BG, T, TB, -SOLAS	REC876114	876114	STD	

MOTORES ENGINES MOTORI	REF	R.O. OEM		
MD21B AQD21B MD32A	REC876161	876161	STD	
MD TMD22	REC859642	859642	STD	
MD2010A, B, C, D MD2020A, B, C, D	RM861954	861954	STD	
	RM861955	861955	050	
MD2030A, B, C, D	RM3580337	3580337	STD	
	RM3580338	3580338	050	
MD2040A, B, C, D	RM3580546	3580546	STD	
	RM3580547	3580547	050	
D1-13A, B, F D1-20A, B, F	RM3812472	3812472	STD	
D1-30A, B, F D2-40A, B, F	RM3812474	3812474	STD	
D2-75A, B, C, F	RM21301848	21301848	STD	

MOTORES ENGINES MOTORI	REF	R.O. OEM	
D2-55A, B, C, D, E, F	RM3583693	3583693	STD
D3-110I-A, I-C, I-B D3-130I-A, I-C, A-A, I-B D3-130I-A-B, A-C D3-160I-A, I-C, A-A, I-B D3-160I-A-B, A-C D3-190I-C, I-B, A-B, A-C D3 (-2003004563)	RM30731740	30731740	STD
D3-110I-G, I-C, I-B, I-D D3-110I-E, I-F D3-130I-C, I-B, A-B, A-C D3-140A-G, I-G, A-D D3-140A-E, A-F D3-150I-G, I-D, I-E, I-F D3-160I-C, I-B, A-B, A-C D3-170A-G, I-G, A-D, A-E D3-170I-D, I-E, A-F, I-F D3-190I-C, I-B, A-B, A-C D3-200A-G, I-G, A-D, A-E D3-200I-D, I-E, A-F, I-F D3-220A-G, I-G, A-D D3-220A-E, I-D, I-E, A-F D3-220I-F D3 (2003004564+)	RM30750678	30750678	STD
D4 D6 SN-A180870 Espesor / Thin / Spessore: 3,50 mm	REC22582994	22582994 3586857	STD
D4 D6 SN-A180871+ Espesor / Thin / Spes- sore: 3,00 mm	REC21711728	21711728	STD
TD30A, 31ACE, 40A TAMD30A, 31A, 31B, 40A, 40B, 41A, 41B TMD30A, 31A, 31B, 40A, 40B, 40C, 41A, 41B AQAD30A, 31A, 40A, 40B, 41A MD30A, 31A 40A AD31A, 31B, 41A, 41B D41A, B 2.3 x 2.5 x 4.0 mm	REC275350	275350	STD
AD31L-A, D-A, P-A, XD AD41D, L-A, P-A D41D, L-A TAMD31D, L-A, M-A, P-A, S-A TAMD41D, H-A, H-B P-A, L-A, M-A TAMD42B, WJ-A TMD31D, L-A TMD41D, L-A KAD32P-A KAD42A, B, P-A KAD43P-A KAMD42A, B, P-A KAMD43P-A 2.8 x 2.5 x 4.0 mm	REC3817033	3817033	STD
TAMD41H-A, H-B, P-A, L-A, M-A KAMD44P-A, P-C KAD44P-A, P-B, P-C KAD300-A KAMD300-A 3.3 x 2.5 x 3.0 mm	REC876775	3586758	STD



## KITS COJINETES BANCADA MAIN BEARING KITS KIT BRONZINE DI BANCO



MOTORES ENGINES MOTORI	REF	R.O. OEM	
AQ60, 90, 95, 100, 105, 110, 115, 120, 120B, 125A, 130, 140A, 145A MB18, 20 BB30, 100	REC271214	271214	STD
AQ125B AQ131A, B AQ145B AQ151A, B AQ171A	REC271237	271237	025
AQ165, 170	REC271217	271217	STD
AQ131C, D 230B, 230A, 250A, 250B, 251A, AQ151C, 171C	REC270906	270906	STD
	REC270907	270907	025



**KITS COJINETES BANCADA  
MAIN BEARING KITS  
KIT BRONZINE DI BANCO**



MOTORES ENGINES MOTORI	REF	R.O. OEM	
MD1B, 2B AQD2B MD3B MD11C, D MD17C, D	RM875483	875483	STD
	RM875485	875485	025
2001, B, AG, BG	RM875773	875773	STD KIT
	RM875774	875774	025 KIT
2002, B, C, AG, BG, D	RM875750	875750	STD KIT
	RM875752	875752	025 KIT
2003, B, D, T, TB, SG, DG, -SOLAS, B-SOLAS, TB-SOLAS	RM875751	875751	STD KIT
	RM875753	875753	025 KIT



MOTORES ENGINES MOTORI	REF	R.O. OEM	
MD21B, A AQD21B, A	REC875306	875306	STD
	REC875307	875307	030
AQD29, 29A MD29, 29A MD32A AQD32A	REC875334	875334	STD
	REC859791	859791	STD
MD22L-A, L-B, P-B, A TMDA, -B TMD22P-C, P-B	REC859945	859945	030
	RM21319767	21319767	STD
D1-13A, B, F 1 ->RM21319767 + 1 ->RM3884517  D1-20A, B, F 1 ->RM21319767 + 2 ->RM3884517	RM3884517	3884517	STD



MOTORES ENGINES MOTORI	REF	R.O. OEM	
D1-30A, B, F	RM21132989	21132989 3884512	STD
D2-40A, B, F	RM21226191	21226191 3884515	STD
D2-50F D2-55A, B, C, D, E, F D2-60F D2-75A, B, C, F	RM877387	877387	STD
D4-180I-B, I-C, I-D, I-E, I-F D4-210A-A, I-A, I-B D4-225A-C, A-D, A-E, A-F, I-C, I-D, I-E, I-F, I-B D4-260A-A, A-B, A-C, A-D, A-E, D-B, D-C, D-E, D-D, I-A, I-B, I-C, I-D, I-E, A-F, D-F, I-F D6-280A-A, A-B, A-C, A-D, A-E, I-A, I-B, I-C, I-D, I-E, D, A-E, D-A, D-C, D-E, D-D, I-A, I-C, I-D, I-E, A-F, D-F, I-F D6-300A-F, D-F (MC), I-F D6-310I-A, A-A, A-B, A-C, A-D, A-E, D-E, I-E, D-B, D-C, D-D, I-B, I-C, I-C D6-330A-B, A-C, A-D, A-E, D-E, I-E, D-B, D-C, D-D, D-F, I-B, I-C, I-D, I-F D6-350A-A, A-B D6-370A-B, A-C, A-D, A-E, D-B, D-C, D-E, D-D, A-F, D-F, I-A, I-B, I-C, I-C, I-EI-F D6-400A-E, A-F D6-435D-A, D-D, D-C, D-E, D-F, I-A, I-C, I-D, I-EI-SC-F, I-WJ-F	RM3586871	3586871	STD
	RM3586877	3586877	STD central central centro
	RM3586873	3586873	025
	RM3586875	3586875	0.50
D9A2A D9-425, 500(R4), 575, D9A-MH D9A2B D9-425, -500(R5), -575, MH D9A2C, D, E, F, G, H, J, K D11B1-A, MP, A-A, A-B, A-C, A-D, A-E, A-D(IPS), A-D(IPS) D12B2-A MP(IPS)	RM20867178	20867178	STD
	RM20867751	20867751	025



MOTORES ENGINES MOTORI	REF	R.O. OEM	
MD2010A, B, C, D	RM876657	876657	STD
	RM876658	876658	025
MD2020A, B, C, D	RM876666	876666	STD
	RM876667	876667	025
MD2030A, B, C, D	RM876660	876660	STD
	RM876661	876661	025
MD2040A, B, C, D	RM876663	876663	STD
	RM876664	876664	025



MOTORES ENGINES MOTORI	REF	R.O. OEM	
AQAD30A MD30A TAMD30A TMD30A AQAD31A MD31A AD31A, B, L-A, P-A, D-A, XD TMD31A, B, D, L-A TAMD31A, B, D, L-A M-A, P-A, S-A KAD32P-A AQD40A AQAD40A, B MD40A TMD40A, B, C TAMD40A, B AQAD41A D41A, B, D AD41A, B, D, L-A, P-A TMD41A, B, D, L-A TAMD41A, B, D, H-A, H-B, P-A, L-A, M-A KAMD42A, B, P-A KAD42A, B, P-A TAMD42B, WJ-A KAMD43P-A KAD43P-A KAMD44P-A,P-C KAD44P-A,P-B,P-C KAD300-A KAMD300-A	REC876515	876515	STD
	REC876516	876516	025
	<b>NEW</b> REC876519	876519	STD central central centro
	REC876520	876520	025 central central centro



MOTORES ENGINES MOTORI	REF	R.O. OEM	
AQ165, 170A, 170B MO-87712 27 mm	REC271054	271054	STD
AQ170B MO 87713- AQ170C 24 mm	REC271066	271066	STD
	REC271067	271067	010
AQ120B, 131, 145B, 151, 171, 230A, 250A, 251A	REC270136	270136	STD
	REC270137	270137	025



**KITS COJINETES BIELA  
CONNETING ROD BEARING KITS  
KIT BRONZINE DI BIELLA** 

MOTORES ENGINES MOTORI	REF	R.O. OEM	
AQ60, 90, 95, 100, 105, 110, 115, 120, 130 MB18, 20 BB30, 100 27 mm	REC271051	271051	STD
	REC271052	271052	010
AQ105, 115, 120B, 125A, 130, 140A, 145A MB20 24 mm	REC271063	271063	STD
	REC271064	271064	010

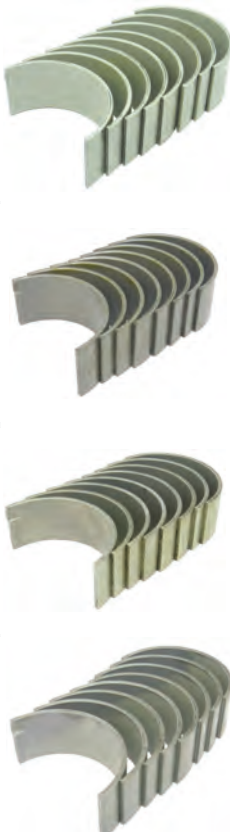

**KITS COJINETES BIELA  
CONNETING ROD BEARING KITS  
KIT BRONZINE DI BIELLA** 

MOTORES ENGINES MOTORI	REF	R.O. OEM	
MD1B, 2B, 3B AQAQ2B MD11C, D MD17C, D	RM875491	875491	STD
	RM875492	875492	025
2001, B, AG, BG 2002, B, D, AG, BG 2003, B, D, T, TB, -SOLAS	RM875747	875747	STD
	RM875748	875748	025



MOTORES ENGINES MOTORI	REF	R.O. OEM	
D1-13A, B, F	RM3884561	3884561	STD
D1-20A, B, F	RM3884557	3884557	STD
MD21A, B AQD21A, B	REC818184	818184	STD
	REC875303	875303	030
MD29, A AQD29, A MD32A AQD32A	REC818184	818184	STD
	REC875331	875331	030
MD22A, L-A, L-B, P-B TMD22A, B, P-C TAMD22P-B	REC859807	859807	STD
	REC859949	859949	030

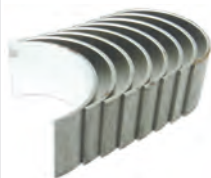
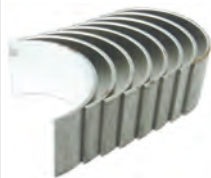

MOTORES ENGINES MOTORI	REF	R.O. OEM	
D1-30A, B, F	RM21252967	21252967	STD
D2-40A, B, F	RM21132990	21132990	STD
D2-50F D2-55A, B, C, D, E, F D2-60F D2-75A, B, C, F	RM877388	877388	STD
D3-110I-A, I-B, I-D, I-E, I-F, I-G, I-H, I-C D3-130A-A, A-B, A-C, I-A, I-B, I-C D3-140A-D, A-E, A-F, A-G, A-H, I-G, I-H D3-150I-D, I-E, I-F, I-G I-H D3-160A-A, A-B, A-C, I-A, I-B, I-C D3-170A-D, A-E, A-F, A-G, A-H, I-D, I-E, I-F, I-G, I-H D3-190A-B, A-C, I-B, I-C D3-200A-D, A-E, A-F, A-G, A-H, I-D, I-E, I-F, I-G, I-H D3-220A-D, A-E, A-F, A-G, A-H, I-D, I-E, I-F, I-G, I-H	RM9180722	31251996	STD
D4-180I-B, I-C, I-D, I-E, I-F D4-225A-E, A-D, A-F, I-C, I-B, I-D, I-E, I-F D4-210A-A, I-A, I-B D4-260A-A, A-B, A-C, A-D, A-E, A-F, D-B, D-C, D-D, D-E, D-F, I-A, I-B, I-C, I-D, I-E, I-F D4-300A-A, A-C, A-D, A-E, A-F, D-A, D-C, D-E, D-D, D-F, D-F(MC), I-D, I-E, I-F D6-280A-A, A-B, A-C, A-D, A-E, I-A, I-B, I-C, I-D, I-E D6-310A-A, A-B, A-C, A-D, A-E, D-B, D-C, D-E, D-D, I-A, I-B, I-C, I-D, I-E D6-330A-B, A-C, A-D, A-E, A-F, D-B, D-C, D-D, D-E, D-F, I-B, I-C, I-D, I-E, I-F D6-350A-A, A-B D6-370A-B, A-C, A-D, A-E, A-F, D-B, D-C, D-D, D-E, D-F, I-A, I-B, I-C, I-D, I-E, I-F D6-400A-E, A-F D6-435D-A, D-C, D-D, D-E, D-F, I-A, I-C, I-D, I-E, I-SC-F, I-WJ-F	RM3586883	3885323	STD
D9-425 D9-500(R4) D9-575, D9-A-MH, MG D9-425, MH D9-500(R5), 575, MH D9A2, A, B, C, D, E, F, G, H, J, K	RM20867177	20867177	STD
	RM20867661	20867661	025

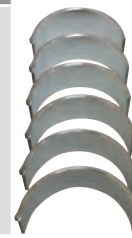



MOTORES ENGINES MOTORI	REF	R.O. OEM	
D11-A MP D11B2-A MP(IPS) D11A-A, A-B, A-C, A-C(IPS), A-D, -A-D(IPS), A-E	RM20856959	20856959	STD
MD2010A, B, C, D	RM876669	876669	STD
	RM876670	876670	025
MD2020A, B, C, D	RM876672	876672	STD
	RM876680	876680	025
MD2030A, B, C, D	RM876682	876682	STD
	RM876683	876683	025
MD2040A, B, C, D	RM876685	876685	STD
	RM876686	876686	025

MOTORES ENGINES MOTORI	REF	R.O. OEM	
AQAD30A MD30A TAMD30A TMD30A AD31A, B, D-A, L-A, P-A, XD AQAD31A TAMD31A, D, B, L-A, M-A, P-A, S-A TMD31A, D, B, L-A MD31A KAD32P-A MD40A TMD40A, B, C TAMD40A, B AQAD40A, B AQD40A AD41A, B, D, L-A, P-A D41A, B, D, L-A AQAD41A TMD41A, B, D, L-A TAMD41A, B, D, H-A, H-B, P-A, L-A, M-A KAMD42A, B, P-A KAD42A, B, P-A TAMD42B, WJ-A KAMD43P-A KAD43P-A KAMD44P-A, P-C KAD44P-A, P-B, P-C KAD300-A KAMD300-A	REC876511	876511	STD
	RM876512	876512	025



**KIT COJINETES  
ÁRBOL DE LEVAS  
BEARING KIT FOR CAM SHAFTS  
KIT BRONZINE ASSE A CAME**



MOTORES ENGINES MOTORI	REF	R.O. OEM	
B21, 23, 25 BB140A, 145A AQ120B, 125A, 125B, 131A, 131B, 131C, 131D 140A, 145A, 145 B, 151A 151B, 151C, 171A, 171C 230A, 230B, 250A, 250B	REC12100		STD



# VÁLVULAS VALVE VALVOLE

## RETENES VÁLVULAS VALVE STEM SEALS PARAOLIO VALVOLE



MOTORES ENGINES MOTORI	RETÉN SEAL PARAOLIO	R.O. OEM	ARO O-RING O-RING	R.O. OEM
AQ120B AQ125A, B AQ131A, B, C, D AQ140A BB140A AQ145A, B BB145A AQ151A, B, C AQ165A BB165A AQ170A, B, C BB170A, B, C 230A, B 250A, B	REC1306630	1306630	REC3514432	3514432
AQ171A, C, 251A	REC3517893	3517860		
3.0GLP-A, -B, -C, -D, -E, -J, -N, 3.0GLM, MDA-A, -B-C 3.0GSP, MDA, -A, -B, -C 3.0HUB, NCA, NCS 3.0GSM-A, -B, -C 3.0HUB, NCA, NCS 3.0GXIC-J 4.3GLMMDA, GSPMDA, GLPHUB, NCA, GSPHUB, HUS, GIPHUSCE, NCACE, NCMCE, CSJNCS, NCM 5.7GLPMDA, GIPMDA, GIPHUS, NCACE, NCMCECE, GLIMDA, GIIMDA, NCSCE			REC26-34217	3854956
740B 7.4GLPMDA, NCA, NCM, M, HUS, GLIMDA, M, HUB, GLPNCS, B, GIPHUSCE, GI- HUBCE, NCCCE, PNCBCE 8.2GLPMDA, M, GLIMDA, M	REC26-75988	3853521		
4.3GLMMDA, GLPMDA, GSPMDA, GSPMDA, GLPHUB, GSPHUB, GSPHUS, GIPHUSCE, GLPNCA, GSJNCS, GSPNCA, GSPNCM, GIPNCA, GIPNCMCE, GLPLKD, GLPLKE, GSPLKD, GSPLKE, GIPLKDC, E, GIPLKE, GSJLKD 5.7GLPMDA, GIPMDA, GIPMDACE, GLIMDA, GIIMDA, GIPHUS, GIPNCA, GIPNCMCE, GIINCSE, GLPK, GSPK, GLIPL	REC70817B	3853226	REC26-34217	3854956
AQ120B, 125, 131, 140, 145, 151, 230A, 250A	REC3514432	3514432		



MOTORES ENGINES MOTORI	RETÉN SEAL PARAOLIO	R.O. OEM
MD1B, 2B, 3B AQD2B MD5A, B, C MD7A, B MD11C, D MD17C, D AQAD30A MD30A TAMD30A TMD30A MD31A AD31B, D-A, L-A, P-A, XD TAMD31B, D, L-A, M-A, P-A, S-A TMD31B, D, L-A	KAD32P-A MD40A TMD40A, B, C AQD40A AQAD40A, B TAMD40A, B, D41B, D, L-A AD41B, D, L-A, P-A TMD41B, D, L-A TAMD41B, D, H-A, H-B, P-A, L-A, M-A KAD42A, B, P-A KAMD42A, B, P-A TAMD42B (OLD STYLE)	REC1306630 1306630
2001, B, AG, BG 2002, B, D, AG, BG 2003, B, D, AG, BG, T, TB, -SOLAS, B-SOLAS, TB-SOLAS AD31A, B, D-A, L-A, P-A, XD AQAD31A MD31A TMD31A, B, D TAMD31A, B, D, L-A, M-A, P-A, S-A TMD31L-A KAD32P-A AD41A, B, D, L-A, P-A D41A, B, D, L-A AQAD41A TMD41A, B, D, L-A TAMD41A, B, D, H-A, H-B, P-A, L-A, M-A KAD42A, B, P-A	KAMD42A, B, P-A TAMD42B, WJ-A KAD43P-A KAMD43P-A TAMD63L-A, P-A TAMD74A-A, A-B, C-A, C-B, L-A, L-B, P-A, P-B TAMD75P-A D9A2A D9-425, -500(R4), -575-MH, -MG D9A2B D9-425-500(R5), -575-MH D9A2E D9-425 D9A2F D9-575 D9A2C, D, E, F, G, H, J, K D12D-A MH, -A MG, -A MP, -B MH, -C MH, -G MH, -A MP, -B MP, -C MP, -D MP, -E MP, -E MG, -F MP, -G MP, -H MP, -E MH, D12C-A MP (NEW STYLE)	REC859171 21501189
MD2030A, B, C, D MD2040A, B, C, D D1-30, B, F D2-40, B, F D2-55B, C, D, E, F MD2010A, B, C, D MD2020A, B, C, D	D2-60F D2-75B, C, F D1-13, B, F D1-20, B, F	REC22393048 22393048 3580305 3580306 REC861860 861860
D3, 4, 6 KAD44 KAMD44	KAD300 KAMD300	REC8631652 8631652 861700 877072 877073 8631652



REC1306630



REC3517893



REC26-75988



REC1306630



REC859171



REC22393048



REC70817B



REC3514432



REC26-34217



REC861860



REC8631652

**NEW**

**NEW**

**NEW**

**VÁLVULAS ADMISIÓN Y ESCAPE  
INTAKE & EXHAUST VALVES  
VALVOLE ASPIRAZIONE E SCARICO**



 MOTORES ENGINES MOTORI		ADMISIÓN INTAKE ASPIRAZIONE	ESCAPE EXHAUST SCARICO	GUÍA ADM. INTAKE GUIDE GUIDA ASPIRAZIONE	GUÍA ESCAPE EXHAUST GUIDE GUIDA SCARICO	RETÉN VÁLVULA SEAL VALVE TENUTA VALVOLA	MUELLE SPRING MOLLA	CIERRE LOCK CHIUSURA	EMPUJADOR LIFTER LIFTER
AQ115A,B,C AQ120B AQ125A,B AQ131A,B,C,D AQ140A	BB140A AQ145A,B BB145A 230A,B 250A,B	REC463395 44 mm	REC463526 35 mm	REC3582606 52x13,5x8mm	REC3582609 52x13,5x8mm	REC1306630	REC463739	REC419643	REC1218630
		R.O. / OEM	R.O. / OEM	R.O. / OEM	R.O. / OEM	R.O. / OEM	R.O. / OEM	R.O. / OEM	R.O. / OEM
		463395	463526	419652	463371	1306630	463739	419643	418423
AQ115A,B BB115A,B,C AQ130A,B,C,D AQ165A	BB165A AQ170A BB170A MB20A,B,C	REC419734 42mm	REC419735 35mm	REC3582606 52x13,5x8mm	REC3582561	REC1306630	REC418737	REC419643	
		R.O. / OEM	R.O. / OEM	R.O. / OEM	R.O. / OEM	R.O. / OEM	R.O. / OEM	R.O. / OEM	R.O. / OEM
		419734	419735	419652	419653	1306630	418737	419643	
AQ171A,C 251A		REC1317793 34,5mm	REC1317792 31,5mm	REC3582608 55x12x7mm	REC3582608 55x12x7mm	REC3517893			
		R.O. / OEM	R.O. / OEM	R.O. / OEM	R.O. / OEM	R.O. / OEM	R.O. / OEM	R.O. / OEM	R.O. / OEM
		1317793	1317792	1378960	1378960	3517860			

 MOTORES ENGINES MOTORI		ADMISIÓN INTAKE ASPIRAZIONE	ESCAPE EXHAUST SCARICO	GUÍA VÁLVULA VALVE GUIDE GUIDA VALVOLA	RETÉN VÁLVULA SEAL VALVE TENUTA VALVOLA	MUELLE SPRING MOLLA	CIERRE LOCK CHIUSURA
MD1B, 2B, 3B MD11C, D MD17C, D		REC833188 38mm	REC829620 34mm		REC1306630		
		R.O. / OEM	R.O. / OEM	R.O. / OEM	R.O. / OEM	R.O. / OEM	R.O. / OEM
		833188	892260		1306630		
MD22A, A-A, L-A, L-B, P-B TMD22A, -A, -B, P-C TAMD22P-B		RM859650	RM859656				
		R.O. / OEM	R.O. / OEM	R.O. / OEM	R.O. / OEM	R.O. / OEM	R.O. / OEM
		859650	859656				
MD2010A, B, C, D MD2020A, B, C, D		RM861858	RM861859		REC861860		
		R.O. / OEM	R.O. / OEM	R.O. / OEM	R.O. / OEM	R.O. / OEM	R.O. / OEM
		861858	861859		861860		
MD2030A, B, C, D		RM3580303	RM3580304		REC22393048		
		R.O. / OEM	R.O. / OEM	R.O. / OEM	R.O. / OEM	R.O. / OEM	R.O. / OEM
		3580303	3580304		3580305		
AQAD30A MD30A TAMD30A TMD30A MD40A TMD40A, B, C AQD40A TAMD40A, B AQAD40A, B AQAD31A AD31A, B, L-A, P-A, D-A, XD TAMD31A, B, D, L-A, M-A, P-A, S-A TMD31A, B, D, L-A MD31A KAD32P-A AQAD41A AD41A, B, D, L-A, P-A D41A, B, D, L-A TAMD41A, B, D, H-A, H-B, P-A, L-A, M-A TMD41A, B, D, L-A KAD42A, B, P-A KAMD42A, B, P-A TAMD42B, WJ-A KAD43P-A KAMD43P-A		REC1542472 42mm	REC1542389 36mm		REC1306630	REC1545198	REC419643
		R.O. / OEM	R.O. / OEM	R.O. / OEM	R.O. / OEM	R.O. / OEM	R.O. / OEM
		1542472	1542389		1306630	1545198	419643
		REC838637 39mm	REC838638 37mm	REC3582561 59x13,5x8mm	REC859171	REC1545198	
		R.O. / OEM	R.O. / OEM	R.O. / OEM	R.O. / OEM	R.O. / OEM	R.O. / OEM
		833637	838638	419653	21501189	1545198	
D1-13A, B, F D1-20A, B, F		RM3809662	RM861859		REC22393048		
		R.O. / OEM	R.O. / OEM	R.O. / OEM	R.O. / OEM	R.O. / OEM	R.O. / OEM
		3809662	861859		22393048		
D1-30A, B, F D2-40A, B, F		RM3884528	RM3580304				
		R.O. / OEM	R.O. / OEM	R.O. / OEM	R.O. / OEM	R.O. / OEM	R.O. / OEM
		3884528	3580304				
D2-55A, B, C, D, E, F D2-60F D2-75A, B, C, F MD2040A, B, C, D		RM21186281	RM21186282		REC22393048		
		R.O. / OEM	R.O. / OEM	R.O. / OEM	R.O. / OEM	R.O. / OEM	R.O. / OEM
		3580478	21307714		22393048		

 MOTORES ENGINES MOTORI	ADMISIÓN INTAKE ASPIRAZIONE	ESCAPE EXHAUST SCARICO	GUÍA VÁLVULA VALVE GUIDE GUIDA VALVOLA	RETÉN VÁLVULA SEAL VALVE TENUTA VALVOLA	MUELLE SPRING MOLLA	CIERRE LOCK CHIUSURA
D3-110I-G, I-A, I-B, I-C, I-D, I-E, I-F, I-H D3-130A-A, A-B, A-C, I-A, I-B, I-C D3-140A-D, A-F, A-E, A-G, A-H, I-E, I-F, I-G, I-H D3-150I-D, I-E, I-F, I-G, I-H D3-160A-A, A-B, A-C, I-A, I-B, I-C D3-170A-D, A-E, A-F, A-G, A-H, I-D, I-E, I-F, I-G, I-H D3-190A-B, A-C, I-B, I-C D3-200A-D, A-E, A-F, A-G, A-H, I-D, I-E, I-F, I-G, I-H D3-220A-D, A-E, A-F, A-G, A-H, I-D, I-E, I-F, I-G, I-H	<b>RM8631650</b> R.O. / OEM 8631650	<b>RM8631651</b> R.O. / OEM 8631651		<b>REC8631652</b> R.O. / OEM 8631652 861700 877072 877073 8631652	R.O. / OEM	R.O. / OEM
D4-180I-B, I-C, I-D, I-E, I-F D4-210A-A, I-A, I-B D4-225A-E, A-C, A-D, A-F, I-B, I-C, I-D, I-E, I-F D4-260A-A, A-B, A-C, A-D, A-E, A-F, D-B, D-C, D-E, D-D, D-F, I-A, I-B, I-C, I-D, I-E, I-F D4-300A-A, A-C, A-D, A-E, A-F, D-A, D-C, D-D, D-E, D-F, I-A, I-C, I-D, I-E, I-F D6-280A-A, A-B, A-C, A-D, A-E, I-A, I-B, I-C, I-D, I-E D6-300A-F, D-F(MC), I-F D6-310A-A, A-B, A-C, A-D, A-E, D-B, D-C, D-E, D-D, I-A, I-B, I-C, I-D, I-E D6-330A-B, A-C, A-D, A-E, A-F, D-B, D-C, D-D, D-E, D-F, I-B, I-C, I-D, I-E, I-F D6-350A-A, A-B D6-370A-B, A-C, A-D, A-E, A-F, D-B, D-C, D-D, D-E, D-F, I-A, I-B, I-C, I-D, I-E, I-F D6-400A-E, A-F D6-435D-A, D-D, D-C, D-E, D-F, I-A, I-C, I-D, I-E, I-SC-F, I-WJ-F	<b>RM3884010</b> R.O. / OEM 3884010	<b>RM3884015</b> R.O. / OEM 3884015		<b>REC8631652</b> R.O. / OEM 8631652 861700 877072 877073 8631652	<b>REC3581889</b> R.O. / OEM 3581889	R.O. / OEM
D9A2A D9-425, 500(R4), 575 D9A-MH, MG D9A2B D9-425, 500(R5), 575, MH D9A2C D9A2E D9-425 D9A2F D9-575 D9A2G, H, J, K D11A-A, A-B, A-C, A-D, A-E, A-C(IPS), A-D(IPS) B1-A MP D11B2-A MP(IPS) D12D-A MH,-A MP,-B MH,-C MH,-G MH,-A MP,-B MP,-C MP,-D MP,-E MH,-E MP,-F MP,-G MP,-G MH,-H MP D12C-A MP D12D-A MG,-E MG	R.O. / OEM	R.O. / OEM		R.O. / OEM	<b>REC3183211</b> <b>REC21310068</b> R.O. / OEM 3183211 21310068	R.O. / OEM
D16C-A MH,-A MG,-B MB,-C MH	<b>REC20739057</b> R.O. / OEM 20739057	<b>REC20513285</b> R.O. / OEM 20513285		R.O. / OEM	<b>REC22527820</b> R.O. / OEM 22527820	R.O. / OEM
KAD44P-A, P-B, P-C KAMD44P-A, P-C KAD300-A KAMD300-A THAMD70C AQD70D,CL TMD70C TAMD70C, D, E MD70C TAMD71A, B TAMD72A, P-A, WJ-A TAMD73P-A, WJ-A	<b>REC861698</b> R.O. / OEM 861698	<b>REC861699</b> R.O. / OEM 861699	R.O. / OEM	<b>REC8631652</b> R.O. / OEM 8631652	<b>REC1545198</b> R.O. / OEM 1545198	R.O. / OEM
	R.O. / OEM 466379	<b>REC842080</b> R.O. / OEM 842080	<b>REC466386</b> R.O. / OEM 466386	<b>REC466384</b> <b>REC466383</b> R.O. / OEM 466384 466383	<b>REC468305</b> R.O. / OEM 468305	<b>REC466382</b> R.O. / OEM 466382

**GUÍAS  
GUIDES  
SEDE**



MOTORES ENGINES MOTORI	ADMISIÓN INTAKE ASPIRAZIONE	R.O. OEM	ESCAPE EXHAUST SCARICO	R.O. OEM
AQ120B, 125, 131, 140, 145, 151, 230, 250	<b>REC3582606</b>	3582606	<b>REC3582609</b>	3582609
AQ171, 251	<b>REC3582608</b>	3582608	<b>REC3582608</b>	3582608
AQ105, 115, 130, 165, 170 MD30, 31, 40, 41 KAD42 KAMD42 D60, 61, 63, 74, 75	<b>REC3582606</b> 52 x 13.5 x 8 mm	3582606	<b>REC3582561</b> 59 x 13.5 x 8 mm	3582561
	<b>REC466386</b>	466386	<b>REC466386</b>	466386

**MUELLES  
SPRINGS  
MOLLE**



MOTORES ENGINES MOTORI	REF	R.O. OEM
AQ 90, 95, 100, 105, 110, 115, 120, 130, 165, 170, MB 18, 20, BB 30, 100, MD 31A (Versión antigua / Old style / versione vecchia)	<b>REC418737</b>	418737
AQ 120B, 125, 131, 140, 145, 151, 230A, 250A	<b>REC463739</b>	463739
30, 31, 32, 40, 41, 42, 43	<b>NEW</b> <b>REC1545198</b>	1545198
D4 D6	<b>NEW</b> <b>REC3581889</b>	3581889

**PRISIONERO VÁLVULA  
VALVE KEEPER  
PRIGIONIERO VALVOLA**

Ref.	R.O. OEM
REC419643	419643

**MOTORES / ENGINES / MOTORI**  
AQ105, 115, 130, 165, 170, 120B, 125, 131,  
140, 145, 151, 230A, 250A  
MB10A  
MD30, 40



**LIFTER**

Ref.	R.O. OEM
REC1218630	1218630

**MOTORES / ENGINES / MOTORI**  
AQ 60, 90, 95, 100, 105, 115, 120A, 130,  
165, 170



**DEPRESOR VÁLVULA  
VALVE DEPRESSOR  
ALZAVÁLVOLA**

Ref.	R.O. OEM
REC463075	463075

**MOTORES / ENGINES / MOTORI**  
AQ120B  
AQ125A, B  
AQ131A, B, C, D  
AQ140A  
AQ145A, B  
AQ151A, B, C  
AQ230A  
AQ250A



**COMPONENETES DE FIJACIÓN  
FIXING COMPONENTS  
COMPONENTI DI FISSAGGIO**

**KIT TORNILLOS CULATA  
BOLT KIT CYLINDER HEAD  
KIT BULLONERIA TESTATA**

Ref.	R.O. OEM
REC1306341	1306341 x 10

**MOTORES / ENGINES / MOTORI**  
AQ120B, 125, 131, 140, 145, 151  
230, 250  
BB140A, 145A



Ref.	R.O. OEM
REC1317761	1326239 x 3 1317761 x 7

**MOTORES / ENGINES / MOTORI**  
AQ171, 251



**TAPÓN ÁRBOL DE LEVAS  
RUBBER WASHER FOR CAMSHAFT  
TAPPO ASSE A CAME**

Ref.	R.O. OEM
REC1336763	1336763

**MOTORES / ENGINES / MOTORI**  
AQ 125, 145B, 151, 230, 250



**TAPONES BLOQUE  
EXPANSION PLUGS  
TAPPI BLOCCO MOTORE**



**TUERCA CULATA  
CYLINDER HEAD NUT  
DADO TESTATA**

Ref.	R.O. OEM	MOTORES ENGINES MOTORI	Piezas necesarias pcs required peze necessita
REC994130	994130	MD1B MB2B, 11C, D MB3B, 17C, D	3 6 8

Incluye Junta  
Gasket Included  
Include guarnizione



MOTORES ENGINES MOTORI	Ø mm	REF	R.O. OEM
AQ 131, 140B, 145, 151, 230, 250, 251	35	REC463903	463903
	40	REC968955	968955
	42	REC463902	463902
	45	REC192212	463904
	52	REC463905	463905
AQ 175A, 205A, 430A,B, 431A,B	26	REC477026	477026
V8	35	REC477024	477024
B18, 20 V-8 MD5, 6, 7 2001, 2002, 2003 D30, 31, 32, 40, 41, 42, 43, 44, 60, 63, 70, 71, 73, 74, 75, 300	26	REC477026	477026 192426
B18, 25 V-8 MD1, 2, 3, 6, 7, 11, 17 2001, 2002, 2003 D60, 63, 70, 71, 73, 72	35	REC477024	477024 192211 463903
B23, 25 V-8 D9, 11, 13, 16, 30, 31, 32, 40, 41, 42, 43, 44, 63, 71, 72, 73, 74, 300	40	REC968955	968955 1542263
B18, 20	42	REC463902	463902 955103
B18, 20, 30 D21	45	REC192212	192212 463904
B21, 23, 25, 30 D30, 31, 32, 40, 41, 42, 43, 44, 300	52	REC463905	463905

**NEW**

**NEW**

# COLECTORES Y CODOS MANIFOLDS & ELBOWS COLLETTORI E GOMITI

AQ115A, B - BB115A, B, C - AQ130A, B, C, D

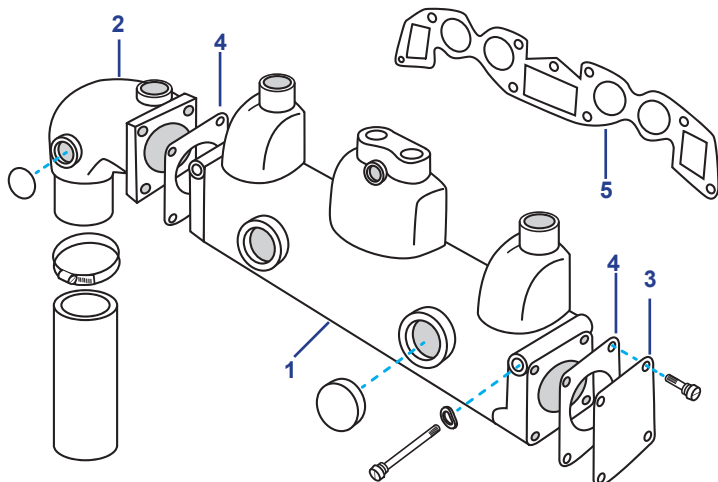

Nº	Ref.	R.O. OEM	Descripción	Description	Descrizione
1	HGE4532	824532	COLECTOR DE ESCAPE	EXHAUST MANIFOLD	COLLETTORE SCARICO
2	HGE5599	825599	CODO ESCAPE	EXHAUST ELBOW	GOMITO SCARICO
3	REC806341	806341	TAPA COLECTOR	CAP	COPERCHIO
4	REC856028	856028	JUNTA TAPA	GASKET CAP	GUARNIZIONE COPERCHIO
5	REC856044	856044	JUNTA COLECTOR ESCAPE	GASKET EXHAUST MANIFOLD	GUARNIZIONE COLLETTORE

AQ120B - AQ125A, B - AQ131A, B, C, D - AQ140A - BB140A  
AQ145A, B - BB145A - AQ151A, B, C - 230A, B - 250A, B

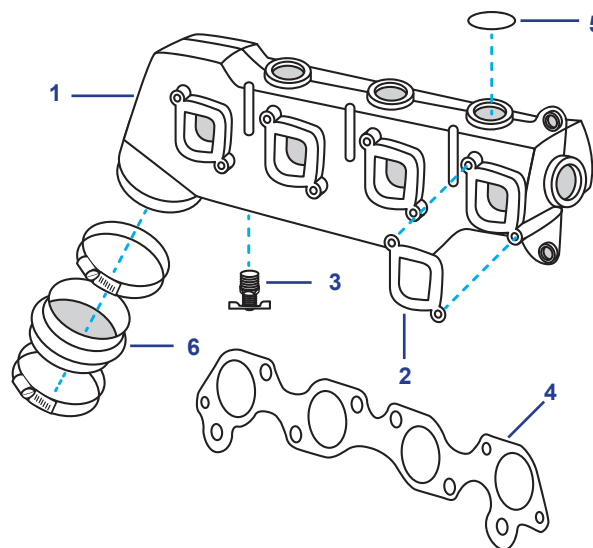

Nº	Ref.	R.O. OEM	Descripción	Description	Descrizione
1	HGE5387	855387	COLECTOR ESCAPE	EXHAUST MANIFOLD	COLLETTORE SCARICO
1	HOT20930	855387	COLECTOR ESCAPE	EXHAUST MANIFOLD	COLLETTORE SCARICO
2	REC855967	855967	JUNTA COLECTOR	GASKET MANIFOLD	GUARNIZIONE COLLETTORE
3	REC82745	997641	TAPÓN DRENAJE	FITTING PLUG	TAPPO DI DRENAGGIO
4	REC1378879	1378879	JUNTA COLECTOR ADMISIÓN	GASKET INTAKE MANIFOLD	GUARNIZIONE COLLETTORE ASPIRAZIONE
5	REC968955	60112158	TAPÓN	PLUG	TAPPO
6	REC834871	834871	FUELLE ESCAPE COLECTOR	BELLOW	CUFFIA

3.0L GM

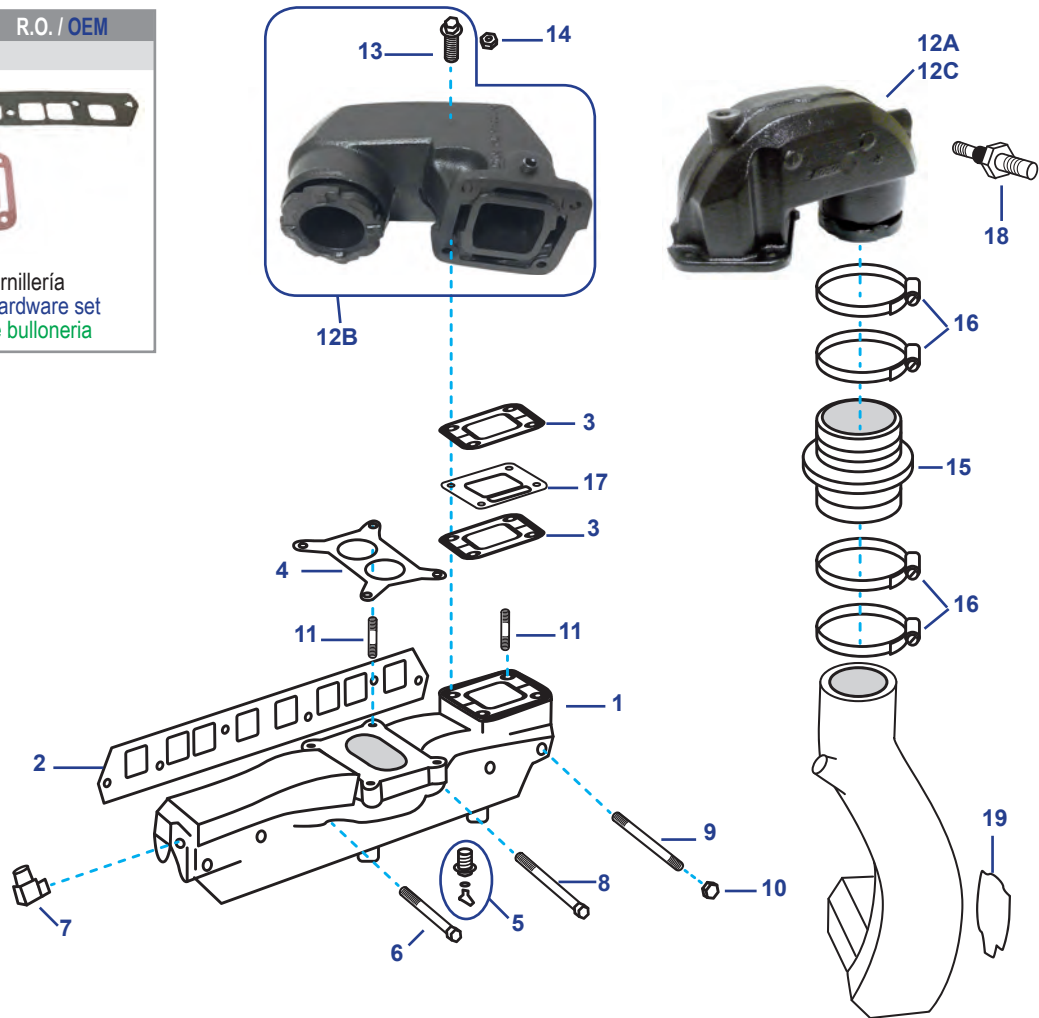

Nº	REF	R.O./OEM	Descripción	Description	Descrizione
1	MAR870	3858870	COLECTOR ESCAPE	EXHAUST MANIFOLD ASSEMBLY	COLLETTORE SCARICO
1	HGE8870	3858870	COLECTOR ESCAPE	EXHAUST MANIFOLD ASSEMBLY	COLLETTORE SCARICO
2	REC27-815528	3853256	JUNTA COLECTOR ESCAPE	GASKET - EXHAUST MANIFOLD	GUARNIZIONE COLLETTORE SCARICO
2	FEL17304	3853256	JUNTA COLECTOR ESCAPE	GASKET - EXHAUST MANIFOLD	GUARNIZIONE COLLETTORE SCARICO
3	REC3850495	3850495	JUNTA CODO ESCAPE	GASKET - EXHAUST ELBOW	GUARNIZIONE GOMITO SCARICO
4	REC3853283	3853283	JUNTA CARBURADOR	GASKET - CARBURETOR	GUARNIZIONE CARBURATORE
5	REC13980	3850802	RÁCOR COLECTOR	STRAIGHT FITTING - WATER DRAIN	RACCORDO COLLETTORE
6	REC3853430	3853430	TORNILLO	SCREW	VITE
7	REC3852538	3852538	RÁCOR COLECTOR	ELBOW FITTING - EXHAUST MANIFOLD	RACCORDO COLLETTORE
8	REC3853431	3853431	TORNILLO	SCREW	VITE
9	REC3853378	3853378	ESPÁRRAGO	STUD - EXHAUST MANIFOLD	PERNO
10	REC46335	3853404	TUERCA	LOCKNUT	DADO
11	REC16-70236	3853373	PERNO	STUD - EXHAUST MANIFOLD	PERNO
12A	BAOMC-20-3862603	3863071	CODO ESCAPE	EXHAUST ELBOW	GOMITO SCARICO ORIGINALE
12B	BAOMC20-910380	3850799	CODO ESCAPE (3.0L mod. MD)	EXHAUST ELBOW FOR 3.0L MODEL MD	GOMITO SCARICO PER 3.0L MOD. MD
12C	RM3588684	3588684	CODO ESCAPE 3.0L GLM - C & 3.0L GLP - C/D/E/J/N	EXHAUST ELBOW 3.0L GLM - C & 3.0L GLP - C/D/E/J/N	GOMITO SCARICO 3.0L GML - C E 3.0L GLP - C/D/E/J/N
13	REC3853397	3853397	TORNILLO CODO	SCREW - EXHAUST ELBOW	VITE GOMITO
14	REC3852142	3852142	TUERCA CODO	NUT - EXHAUST ELBOW	DADO GOMITO
15	REC3863450	3863450	MANGUITO	EXHAUST HOSE	MANICOTTO
16	GS38320	3852604	ABRAZADERA	CLAMP	FASCETA
17	REC3853628	3853628	PLACA INTERMEDIA	INTERMEDIATE PLATE	PIASTRA INTERMEDIA
18	REC3862500	38622500	SENSOR TEMPERATURA	TEMPERATURE SENDER	SENSORE TEMPERATURA
19	RM3587651	3587651	JUNTA CUERNO ESCAPE	GASKET EXHAUST PIPE	GUARNIZIONE CORNA DI SCARICO

6L AQ 165 & 170 A, B, C

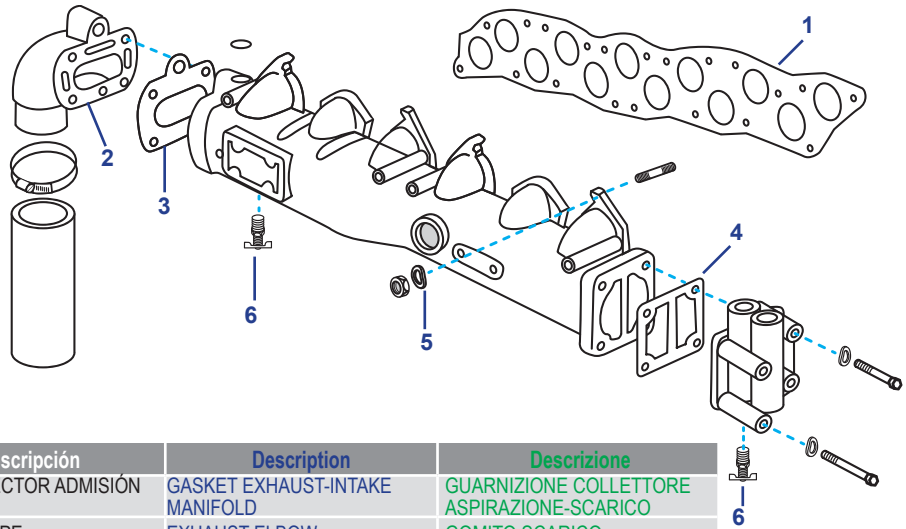

Nº	REF	R.O./OEM	Descripción	Description	Descrizione
1	REC1378913	461092	JUNTA COLECTOR ADMISIÓN - ESCAPE	GASKET EXHAUST-INTAKE MANIFOLD	GUARNIZIONE COLLETTORE ASPIRAZIONE-SCARICO
2	RM831834-7	831834	CODO ESCAPE	EXHAUST ELBOW	GOMITO SCARICO
3	REC856042	856042	JUNTA CODO	ELBOW GASKET	GUARNIZIONE GOMITO
4	REC856036	856036	JUNTA TAPA	CAP GASKET	GUARNIZIONE COPERCHIO
5	REC941907	941907	ARANDELA	WASHER	RONDELLA
6	REC82744	82744	TAPÓN DRENAJE	FITTING PLUG	TAPPO DI DRENAGGIO

V6 AQ 175 - AQ 205 - AQ430 A/B - 431 A/B - AQ 434 (-1993)

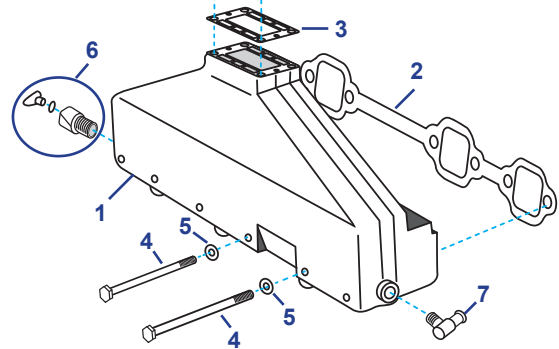
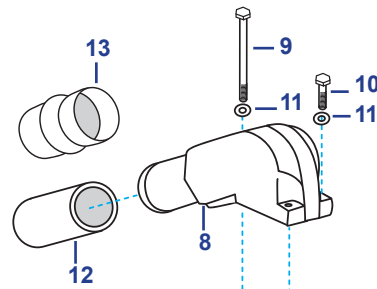

Nº	REF	R.O./OEM	Descripción	Description	Descrizione
1	HGE6894	856894	COLECTOR ESCAPE	EXHAUST MANIFOLD	COLLETTORE SCARICO
2	REC27-99757	856116	JUNTA COLECTOR ESCAPE	GASKET - EXHAUST MANIFOLD	GUARNIZIONE COLLETTORE SCARICO
2	FEL17410	856116	KIT JUNTAS COLECTOR ESCAPE	GASKET KIT - EXHAUST MANIFOLD	KIT GUARNIZIONE COLLETTORE SCARICO
3	REC857618	857618	JUNTA CODO ESCAPE NO PARA HGE	GASKET - EXHAUST ELBOW NOT FOR HGE	GUARNIZIONE GOMITO SCARICO NO PER HGE
3	HGE35908		JUNTA CODO ESCAPE PARA HGE	GASKET - EXHAUST ELBOW FOR HGE	GUARNIZIONE GOMITO SCARICO PER HGE
4	REC942547	942547	TORNILLO	SCREW	VITE
5	REC942336	942336	ARANDELA	WASHER	RONDELLA
6	REC479956	479956	RÁCOR DRENAJE	FITTING PLUG	RACCORDO DI DRENAGGIO
7	REC3852538	3852538	RÁCOR COLECTOR	HOSE FITTING	RACCORDO COLLETTORE
8	HGE7037	857037	CODO ESCAPE	EXHAUST ELBOW	GOMITO SCARICO
9	REC959796	959796	TORNILLO	SCREW	VITE
10	REC940136	940136	TORNILLO	SCREW	VITE
11	REC941907	941907	ARANDELA	WASHER	RONDELLA
12	REC834751	834751	MANGUITO ESCAPE	EXHAUST HOSE	MANICOTTO SCARICO
13	REC854935	854935	MANGUITO ESCAPE	EXHAUST HOSE	MANICOTTO SCARICO



**V6 4.3L GM 262 CID (1993+)**

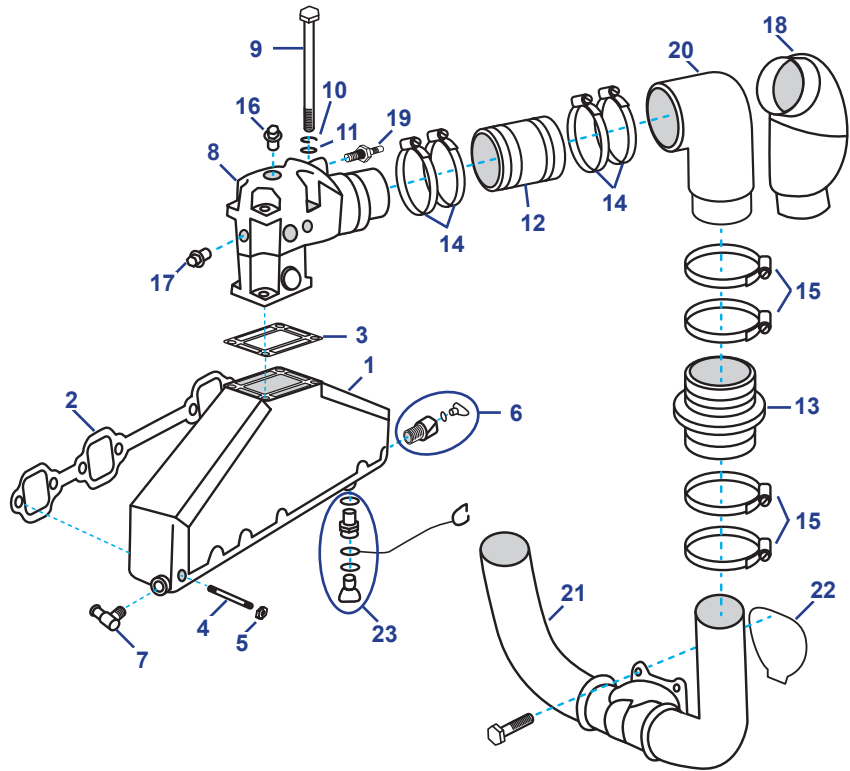
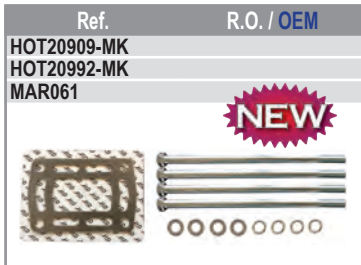
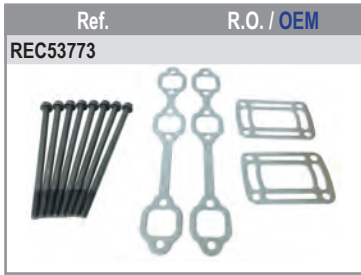

Nº	REF	R.O./OEM	Descripción	Description	Descrizione
1	MAR499	3847499	COLECTOR ESCAPE	EXHAUST MANIFOLD ASSEMBLY	COLLETTORE SCARICO
2	REC27-99757	3853412	JUNTA COLECTOR ESCAPE	GASKET - EXHAUST MANIFOLD	GUARNIZIONE COLLETTORE SCARICO
2	FEL17410	3853412	KIT JUNTAS COLECTOR ESCAPE	GASKET KIT - EXHAUST MANIFOLD	KIT GUARNIZIONE COLLETTORE SCARICO
3	REC3863191	3863191	JUNTA CODO ESCAPE	GASKET KIT - EXHAUST ELBOW	GUARNIZIONE GOMITO SCARICO
4	REC3852467	3852467	ESPÁRRAGO	STUD	VITE
5	REC46335	3853404	TUERCA	NUT	DADO
6	REC479956	479956	RÁCOR COLECTOR	STRAIGHT FITTING KIT	RACCORDO COLLETTORE
7	REC3852538	3852538	RÁCOR CODO	ELBOW FITTING	RACCORDO GOMITO
8	MAR061	3863061	CODO ESCAPE 19.7cm	EXHAUST ELBOW ASSEMBLY 19.7cm	GOMITO SCARICO 19.7cm
8	RM3862627	3862627	CODO ALTO 28.7 cm	EXHAUST ELBOW HIGH 28.7 cm	GOMITO SCARICO 28.7 cm
8	MAR627	3862627	CODO ALTO 28.7 cm	EXHAUST ELBOW HIGH 28.7 cm	GOMITO SCARICO 28.7 cm
8	HOT20909	3863061	CODO ESCAPE 19.7 cm	EXHAUST ELBOW ASSEMBLY 19.7cm	GOMITO SCARICO 19.7cm
8	REC3889964	3889964	CODO ALTO 25.7 cm	EXHAUST ELBOW HIGH 25.7 cm	GOMITO SCARICO 25.7 cm
9	REC3852830	3852830	TORNILLO	SCREW	VITE
10	REC13-35048	3852002	GROOVER	GROOVER	GROOVER
11	REC21-20553	3852058	ARANDELA	WASHER	RONDELLA
12	REC3852696	3852696	MANGUITO ESCAPE	EXHAUST HOSE	MANICOTTO SCARICO
13	REC3863450	3863450	MANGUITO ESCAPE	EXHAUST HOSE	MANICOTTO SCARICO
14	GS38322	3863443	ABRAZADERA	CLAMP	FASCETTA
15	GS38320	3852604	ABRAZADERA	CLAMP	FASCETTA
16	REC22-73379	3850740	TAPÓN	PLUG	TAPPO
17	REC22-428611	3852135	TAPÓN	PLUG	TAPPO
18	RM3854874	3854874	CURVA ESCAPE 4.3L COLA SX	EXHAUST CURVE	CURVA SCARICO 4.3L PIEDE SX
19	REC3862500	3862500	SENSOR TEMPERATURA	TEMPERATURE SENSOR	SENSORE TEMPERATURA
20	RM3863189	3863189	CURVA ESCAPE	EXHAUST CURVE	CURVA SCARICO
21	RM3858873	3858873	CUERNOS ESCAPE SX	EXHAUST TUBO SX	CORNA DI SCARICO SX
22	RM3587651	3587651	JUNTA ESCAPE	EXHAUST GASKET	GUARNIZIONE SCARICO
23	REC38201	21114522	KIT TAPÓN DRENAJE	FITTING PLUG KIT	KIT TAPPO DI DRENAGGIO

**NEW**

**NEW**

AQ & BB 200, 205, 211, 231, 225, 260, 271, 290, 311, 500, 501, 570, 571, 572 GM 305/350 CID, (-1993)

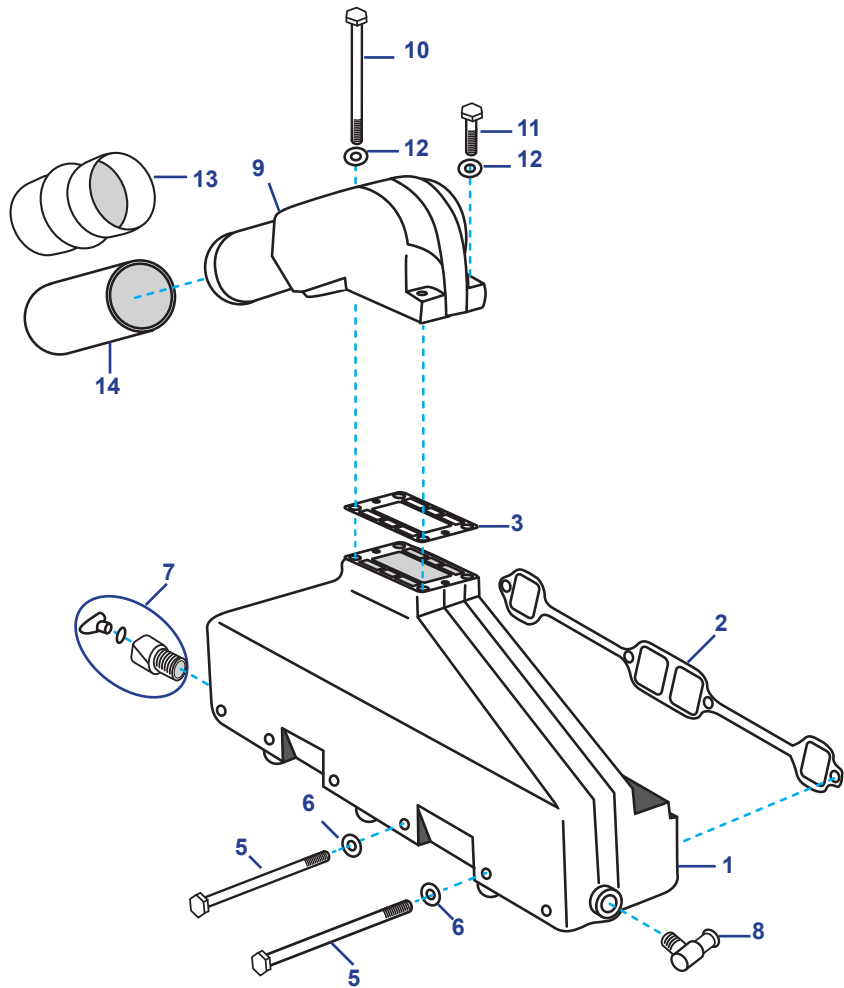

Nº	REF	R.O./OEM	Descripción	Description	Descrizione
1	HOT20931	856883	COLECTOR ESCAPE	EXHAUST MANIFOLD ASSEMBLY	COLLETTORE SCARICO
2	REC27-33395	856034	JUNTA COLECTOR ESCAPE	GASKET - EXHAUST MANIFOLD	GUARNIZIONE COLLETTORE SCARICO
2	FEL17420	856034	KIT JUNTAS COLECTOR ESCAPE	GASKET KIT - EXHAUST MANIFOLD	KIT GUARNIZIONE COLLETTORE SCARICO
3	REC857618	857618	JUNTA CODO ESCAPE	GASKET - EXHAUST ELBOW	GUARNIZIONE GOMITO SCARICO
5	REC942547	942547	TORNILLO	SCREW	VITE
6	REC942336	942336	ARANDELA	WASHER	RONDELLA
7	REC479956	479956	RÁCOR DRENAJE	STRAIGHT FITTING KIT	RACCORDO DI DRENAGGIO
8	REC3852538	3852538	RÁCOR COLECTOR	HOSE FITTING	RACCORDO GOMITO
9	HOT20935	856891	CODO ESCAPE	EXHAUST ELBOW ASSEMBLY	GOMITO SCARICO
10	REC959794	959794	TORNILLO	SCREW	VITE
11	REC940136	940136	TORNILLO	SCREW	VITE
12	REC941907	941907	ARANDELA	WASHER	RONDELLA
13	REC834751	834751	MANGUITO ESCAPE	EXHAUST HOSE	MANICOTTO SCARICO
14	REC854935	854935	MANGUITO ESCAPE	EXHAUST HOSE	MANICOTTO SCARICO

**V8 5.0/5.7L GM305 & GM 350 CID  
(1993+)**

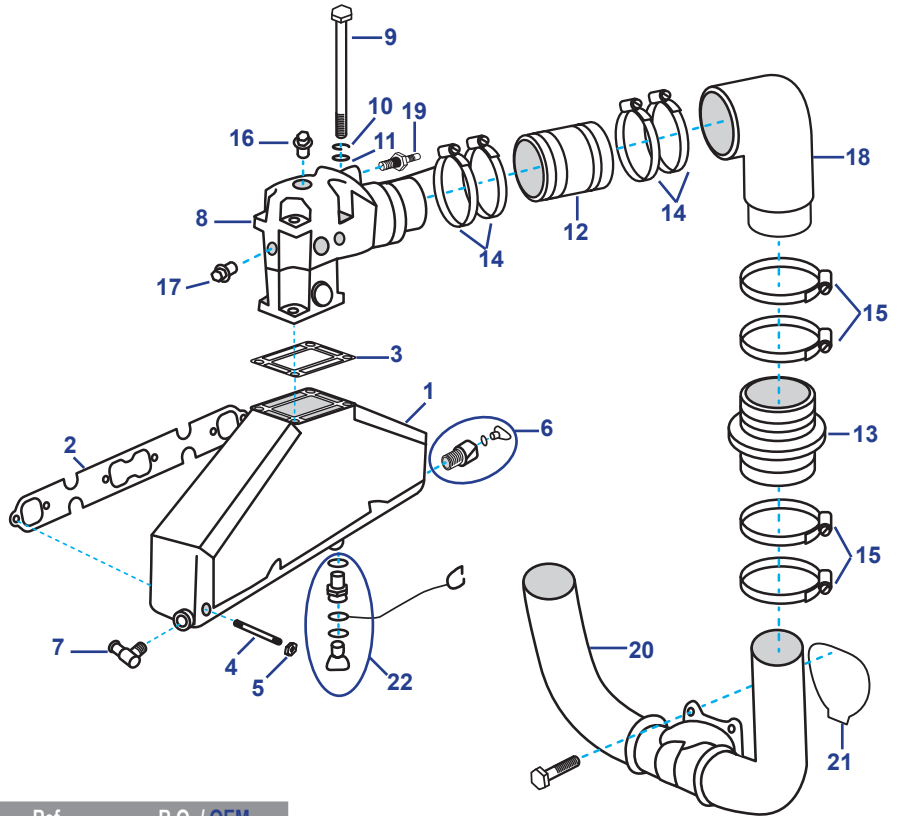
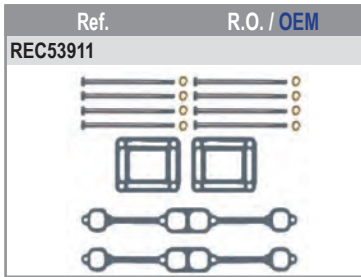

**NEW**

**NEW**

Nº	REF	R.O./OEM	Descripción	Description	Descrizione
1	MAR501	3847501	COLECTOR ESCAPE	EXHAUST MANIFOLD ASSEMBLY	COLLETTORE SCARICO
1	HOT20986	3847501	COLECTOR ESCAPE	EXHAUST MANIFOLD ASSEMBLY	COLLETTORE SCARICO
2	REC27-33395	3852468	JUNTA COLECTOR ESCAPE	GASKET - EXHAUST MANIFOLD	GUARNIZIONE COLLETTORE SCARICO
2	FEL17420	3852468	KIT JUNTAS COLECTOR ESCAPE	GASKET KIT - EXHAUST MANIFOLD	KIT GUARNIZIONE COLLETTORE SCARICO
3	REC3863191	3863191	JUNTA CODO ESCAPE	GASKET - EXHAUST ELBOW	GUARNIZIONE GOMITO SCARICO
4	REC3852467	3852467	PERNO	STUD	VITE
5	REC46335	3853404	TUERCA	NUT	DADO
6	REC479956	479956	RÁCOR COLECTOR	STRAIGHT FITTING KIT	RACCORDO COLLETTORE
7	REC3852538	3852538	RÁCOR COLECTOR	ELBOW FITTING	RACCORDO COLLETTORE
8	MAR061	3863061	CODO ESCAPE 19.7 cm	EXHAUST ELBOW ASSEMBLY 19.7 cm	GOMITO SCARICO 19.7 cm
8	HOT20909	3863061	CODO ESCAPE 19.7 cm	EXHAUST ELBOW ASSEMBLY 19.7 cm	GOMITO SCARICO 19.7 cm
8	RM3862627	3862627	CODO ESCAPE ALTO 28.7 cm	EXHAUST ELBOW HIGH 28.7 cm	GOMITO SCARICO ALTO 28.7 cm
8	MAR627	3862627	CODO ALTO 28.7 cm	EXHAUST ELBOW HIGH 28.7 cm	GOMITO SCARICO 28.7 cm
8	REC3889964	3889964	CODO ESCAPE ALTO 25.7 cm	EXHAUST ELBOW HIGH 25.7 cm	GOMITO SCARICO ALTO 25.7 cm
9	REC3852830	3852830	TORNILLO	SCREW	VITE
10	REC13-35048	3852002	CIERRE	LOCKWASHER	CHIUSURA
11	REC21-20553	3852058	ARANDELA	WASHER	RONDELLA
12	REC3852696	3852696	MANGUITO ESCAPE	EXHAUST HOSE	MANICOTTO SCARICO
13	REC3863450	3863450	MANGUITO ESCAPE	EXHAUST HOSE	MANICOTTO SCARICO
13	RM3863450	3863450	MANGUITO ESCAPE	EXHAUST HOSE	MANICOTTO SCARICO
14	GS38322	3863443	ABRAZADERA	CLAMP	FASCETTA
15	GS38320	3852604	ABRAZADERA	CLAMP	FASCETTA
16	REC22-73379	3850740	TAPÓN	PLUG	TAPPO
17	REC22-428611	3852135	TAPÓN	PLUG	TAPPO
18	RM3863189	3863189	CURVA ESCAPE MODERNO	EXHAUST CURVE	CURVA SCARICO MODERNO
19	REC3862500	3862500	SENSOR TEMPERATURA	TEMPERATURE SENSOR	SENSORE TEMPERTURA
20	RM3858873	3858873	CUERNOS ESCAPE SX	EXHAUST TUBO SX	CORNA DI SCARICO SX
21	RM3587651	3587651	JUNTA ESCAPE	EXHAUST GASKET	GUARNIZIONE SCARICO
22	REC38201	38201	KIT TAPÓN DRENAJE	FITTING PLUG KIT	KIT TAPPO DI DRENAGGIO

## 5.0/5.8L & F1/FSI FORD 302/351 CID V8 (1993+)

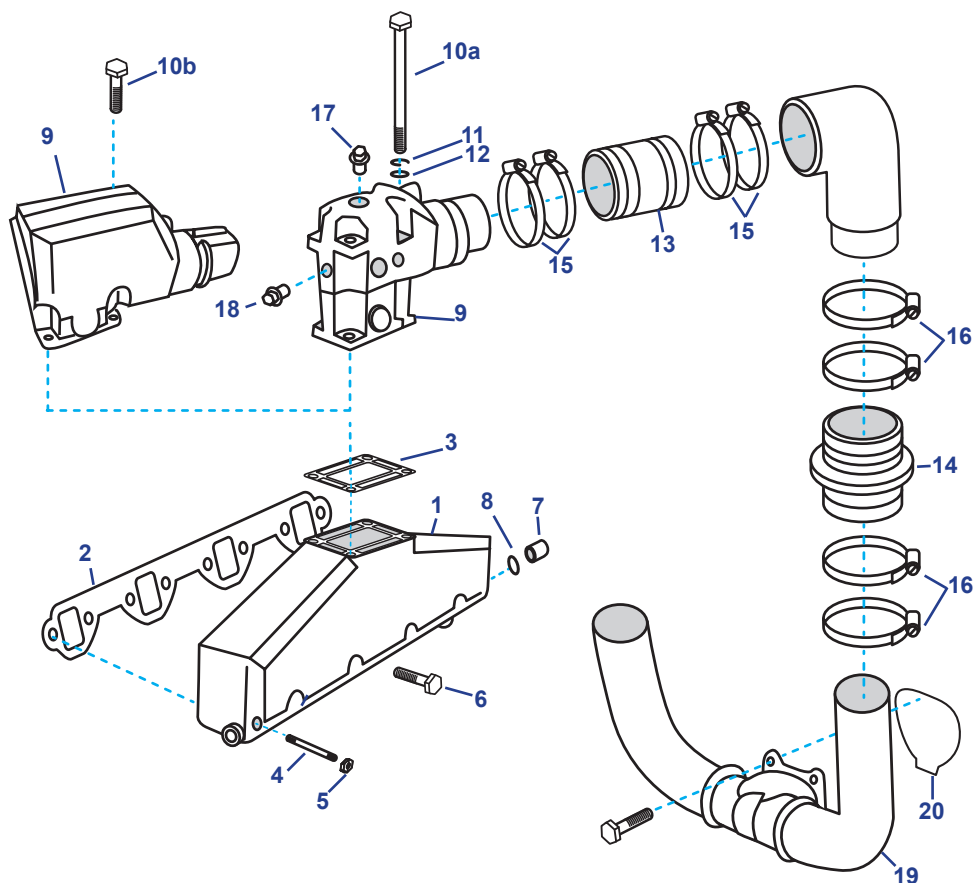

Nº	REF	R.O./OEM	Descripción	Description	Descrizione
1	BAOMC1-3852347	3852347	COLECTOR ESCAPE	EXHAUST MANIFOLD ASSEMBLY	COLLETTORE SCARICO
2	REC3852455	3852455	JUNTA COLECTOR ESCAPE	GASKET - EXHAUST MANIFOLD	GUARNIZIONE COLLETTORE SCARICO
2	FEL17460	3852455	KIT JUNTAS COLECTOR ESCAPE	GASKET KIT - EXHAUST MANIFOLD	KIT GUARNIZIONE COLLETTORE SCARICO
3	REC3863191	3863191	JUNTA CODO ESCAPE	GASKET - EXHAUST ELBOW	GUARNIZIONE GOMITO SCARICO
4	REC3853434	3853434	ESPÁRRAGO	STUD	PERNO
5	REC46335	3853404	TUERCA	NUT	DADO
6	REC10-37612	3853155	TORNILLO	SCREW	VITE
7	REC3852476	3852476	TAPA	CAP	COPERCHIO
8	REC3852602	3852602	ABRAZADERA	CLAMP	FASCETTA
9	MAR061	3863061	CODO ESCAPE 19.7 cm	EXHAUST ELBOW ASSEMBLY 19.7 cm	GOMITO SCARICO 19.7 cm
9	HOT20909	3863061	CODO ESCAPE 19.7 cm	EXHAUST ELBOW ASSEMBLY 19.7 cm	GOMITO SCARICO 19.7 cm
9	REC3855271	3855271	CODO ESCAPE EFI BABOR	EXHAUST ELBOW ASSEMBLY - PORT (EFI)	GOMITO SCARICO EFI BABORDO
9	REC3855269	3855269	CODO ESCAPE EFI ESTRIBOR	EXHAUST ELBOW ASSEMBLY - STBD (EFI)	GOMITO SCARICO EFI TRIBORDO
10a	REC3852830	3852830	TORNILLO (1988-96 CARBURACION)	SCREW (1988-96 CARBURATION)	VITE (1988-96 CARBURATORE)
10b	REC10-37612	3855983	TORNILLO (1993-96 EFI)	SCREW (1993-96 EFI)	VITE (1993-96 EFI)
11	REC13-35048	3852002	CIERRE	LOCKWASHER	CHIUSURA
12	REC21-20553	3852058	ARANDELA	WASHER	RONDELLA
13	REC3852696	3852696	MANGUITO ESCAPE	EXHAUST HOSE	MANICOTTO SCARICO
14	REC3863450	3863450	MANGUITO ESCAPE	EXHAUST HOSE	MANICOTTO SCARICO
15	GS38322	3863443	ABRAZADERA	CLAMP	FASCETTA
16	GS38320	3852604	ABRAZADERA	CLAMP	FASCETTA
17	REC22-73379	3850740	TAPÓN	PLUG	TAPPO
18	REC22-428611	3852135	TAPÓN	PLUG	TAPPO
19	RM3858873	3858873	CUERNOS ESCAPE SX	EXHAUST TUBO SX	CORNA DI SCARICO SX
20	RM3587651	3587651	JUNTA ESCAPE	EXHAUST GASKET	GUARNIZIONE SCARICO

**NEW**

V8 7.4/8.2 GM 454/502 CID (1992+)

Ref.	R.O. / OEM
RM3862627	3862627



Codo escape alto  
Extra tall exhaust riser  
Gomito rialzato

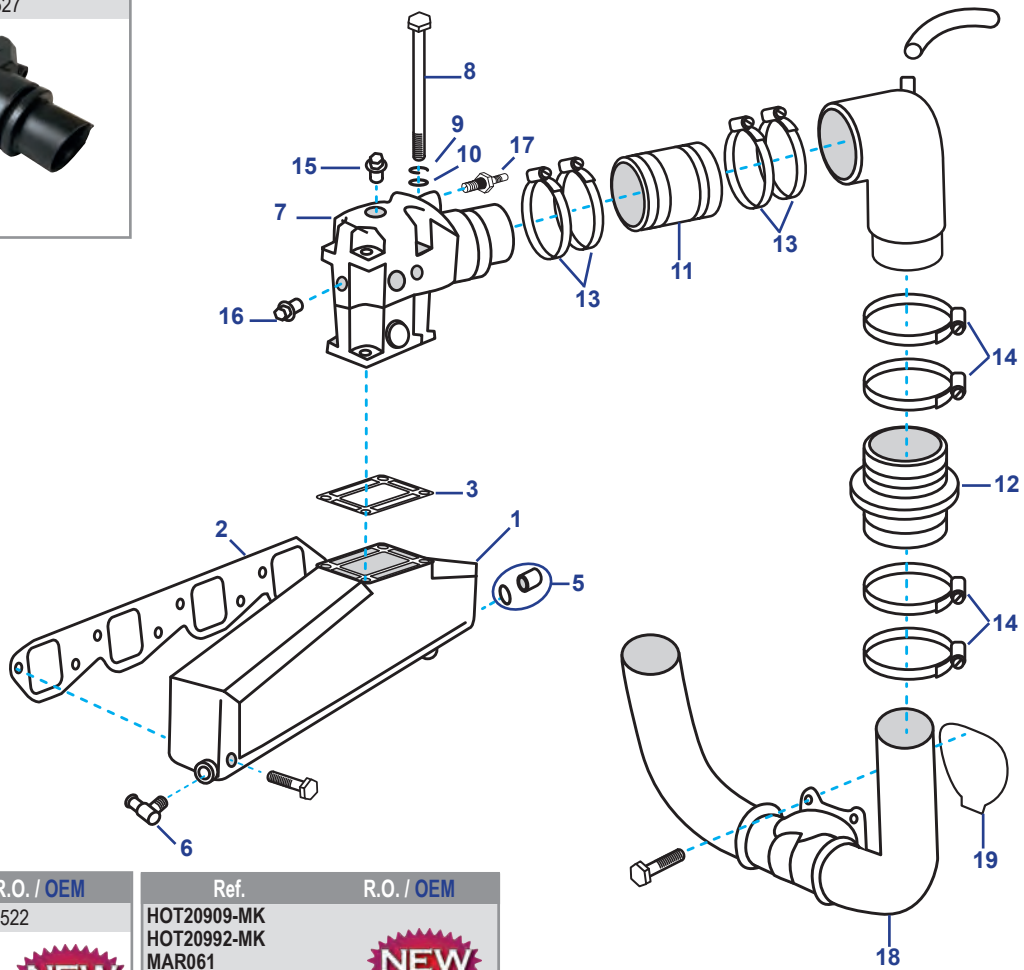

Ref.	R.O. / OEM
REC38201	21114522



Rácor colector original  
Manifold original fitting  
Racordo collettore originale

**NEW**

Ref.	R.O. / OEM
HOT20909-MK HOT20992-MK MAR061	



**NEW**

Nº	REF	R.O./OEM	Descripción	Description	Descrizione
1	RM3861459	3861459	COLECTOR ESCAPE	EXHAUST MANIFOLD ASSEMBLY	COLLETTORE SCARICO
2	REC27-46820	3852472	JUNTA COLECTOR ESCAPE	GASKET - EXHAUST MANIFOLD	GUARNIZIONE COLLETTORE SCARICO
2	FEL17440	3852472	KIT JUNTAS COLECTOR ESCAPE	GASKET KIT - EXHAUST MANIFOLD	KIT GUARNIZIONE COLLETTORE SCARICO
3	REC3863191	3863191	JUNTA CODO ESCAPE	GASKET - EXHAUST ELBOW	GUARNIZIONE GOMITO SCARICO
4	REC10-37612	3855983	TORNILLO	SCREW	PERNO
5	REC479956	479956	RÁCOR COLECTOR	STRAIGHT FITTING KIT	RACORDO COLLETTORE
6	REC3852538	3852538	RÁCOR CODO	ELBOW FITTING	RACORDO GOMITO
7	MAR061	3863061	CODO ESCAPE 19.7 cm	EXHAUST ELBOW ASSEMBLY 19.7 cm	GOMITO SCARICO 19.7 cm
7	HOT20909	3863061	CODO ESCAPE 19.7 cm	EXHAUST ELBOW ASSEMBLY 19.7 cm	GOMITO SCARICO 19.7 cm
7	RM3862627	3862627	CODO ESCAPE ALTO 28.7 cm	EXHAUST ELBOW HIGH 28.7 cm	GOMITO SCARICO ALTO 28.7 cm
7	REC3889964	3889964	CODO ESCAPE ALTO 25.7 cm	EXHAUST ELBOW HIGH 25.7 cm	GOMITO SCARICO ALTO 25.7 cm
8	REC3852830	3852830	TORNILLO	SCREW	VITE
9	REC13-35048	3852002	CIERRE	LOCKWASHER	CHIUSURA
10	REC21-20553	3852058	ARANDELA	WASHER	RONDELLA
11	REC3852696	3852696	MANGUITO ESCAPE	EXHAUST HOSE	MANICOTTO SCARICO
12	REC3863450	3863450	MANGUITO ESCAPE	EXHAUST HOSE	MANICOTTO SCARICO
13	GS38322	3863443	ABRAZADERA	CLAMP	FASCETTA
14	GS38320	3852604	ABRAZADERA	CLAMP	FASCETTA
15	REC22-73379	3850740	TAPÓN	PLUG	TAPPO
16	REC22-428611	3852135	TAPÓN	PLUG	TAPPO
17	REC3862500	3862500	SENSOR TEMPERATURA	TEMPERATURE SENSOR	SENSORE TEMEPERATURA
18	RM3858873	3858873	CUERNOS ESCAPE SX	EXHAUST TUBO SX	CORNA DI SCARICO SX
19	RM3587651	3587651	JUNTA ESCAPE	EXHAUST GASKET	GUARNIZIONE SCARICO

**COLECTORES ESCAPE GASOLINA**  
**FUEL EXHAUST MANIFOLD**  
**COLLETTORE SCARICO BENZINA**



Ref.	R.O. OEM
HOT20930	855387
HGE5387	834438



**MOTORES / ENGINES / MOTORI**

230A, B	AQ140A
250A, B	BB140A,
AQ120B	AQ145A, B
AQ125A, B	BB145A
AQ131A, B, C, D	AQ151A, B, C



Ref.	R.O. OEM
MAR870	3858870
HGE8870	3858871
	3857450
	3854045



**MOTORES / ENGINES / MOTORI**

3.0GPS, GSM, GLP, GLM



Ref.	R.O. OEM
HGE6894	856894
	856137
	841676



**MOTORES / ENGINES / MOTORI**

430A, B  
 431A, B  
 432A  
 434A  
 AQ205A  
 AQ175A  
 V6 (-1993)



Ref.	R.O. OEM
MAR499	3847499
	3857656
	3852338
	3857678



**MOTORES / ENGINES / MOTORI**

4.3GL, GXI, GI, GS, OSI,  
 V6-200-A  
 V6-225-A  
 V6 (1993+)



Ref.	R.O. OEM
HOT20931	856883
	855926
	835804



**MOTORES / ENGINES / MOTORI**

AQ200D, F  
 AQ211A  
 AQ225D, E, F  
 BB225  
 AQ231A, B  
 BB231  
 AQ260A, B  
 BB260  
 BB261  
 AQ271A, B, C, D  
 AQ290A  
 AQ311A, B  
 500A, B  
 501A, B  
 570A  
 571A  
 572A



Ref.	R.O. OEM
MAR501	3847501
HOT20986	3857723
	3852374



**MOTORES / ENGINES / MOTORI**

5.0GX1, OSI, GL, GI, GSI  
 5.7GI, GXI, GSI, GL, OSI, OSX  
 V8-270, 300, 320



Ref.	R.O. OEM
BAOMC1-3852347	3852347



**MOTORES / ENGINES / MOTORI**

5.0 & 5.8 FIP, FLP, FLI, FSI (Base Ford 302/351)



Ref.	R.O. OEM
RM3861459	3861459 3852362



**MOTORES / ENGINES / MOTORI**  
7.4GLP, GLI, GI, GSI, GL  
8.2GLP, GLI, GSI (454/502)



Ref.	R.O. OEM
HGE4532	824532



**MOTORES / ENGINES / MOTORI**  
AQ115A, B  
BB115A, B, C  
AQ130A, B, C, D



**CODOS ESCAPE  
EXHAUST ELBOWS  
GOMITI SCARICO**



Ref.	R.O. OEM
HGE5599	825599 825598



**MOTORES / ENGINES / MOTORI**  
AQ115A, B,  
AQ130A, B, C, D



Ref.	R.O. OEM
RM3588684	3588684 3588683



**MOTORES / ENGINES / MOTORI**  
3.0GLM-C  
3.0GLP-C, D, E, J, N  
(2003+)



Ref.	R.O. OEM
BAOMC20-910380	3850799



**MOTORES / ENGINES / MOTORI**  
3.0L MD



Ref.	R.O. OEM
RM831834-7	831834



**MOTORES / ENGINES / MOTORI**  
AQ170B, C



Ref.	R.O. OEM
BAOMC-20-3862603	3863071
	3857798
	3856662
	3851227
	3856617
	3857810 3857684



**MOTORES / ENGINES / MOTORI**  
3.0GSP, GSM, GLP, GLM  
(1994-03)



Ref.	R.O. OEM
HGE7037	857037 856895 855380



**MOTORES / ENGINES / MOTORI**  
430A, B  
431A, B  
432A  
434A  
AQ205A  
AQ175A



Ref.	R.O. OEM
MAR061 HOT20909	3863061
	3861842
	3856444
	3855270
	3854466
	3857402
3862198	

DESPIECE  
PARTS  
ESPLOSO  
P. 320, 322, 323, 324

**NEW**

MOTORES / ENGINES / MOTORI  
V6 - V8 (1993+)  
19.7 cm



Ref.	R.O. OEM
REC3889964	3889964

DESPIECE  
PARTS  
ESPLOSO  
P. 324

**NEW**

MOTORES / ENGINES / MOTORI  
4.3GL, GXI, OSI  
V6-200, 225  
(1993+)  
25.7 cm



Ref.	R.O. OEM
RM3862627 MAR627	3862627 3862904

DESPIECE  
PARTS  
ESPLOSO  
P. 320, 322, 324

MOTORES / ENGINES / MOTORI  
V6 - V8 (1993+)  
28.7 cm



Ref.	R.O. OEM
HOT20935	856891 855384

DESPIECE  
PARTS  
ESPLOSO  
P. 321

**NEW**

MOTORES / ENGINES / MOTORI  
500, 501, 570, 572  
AQ200, 211, 225, 231, 260, 271, 290, 311  
BB225, 231, 260, 261

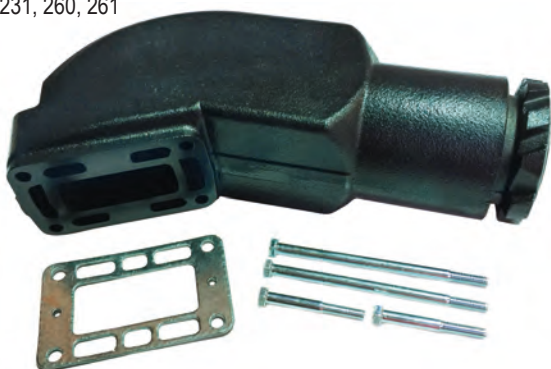

**CODO ESCAPE BABOR  
EXHAUST ELBOW PORT  
GOMITO SCARICO SINISTRA**

Ref.	R.O. OEM
REC3855271	3855271 3850913 3853568 3854428

DESPIECE  
PARTS  
ESPLOSO  
P. 323

MOTORES / ENGINES / MOTORI  
5.0FIP  
5.8FIP, FII, FSI



**CODO ESCAPE ESTRIBOR  
EXHAUST ELBOW STD  
GOMITO SCARICO DESTRA**

Ref.	R.O. OEM
REC3855269	3855269 3853567 3854427

DESPIECE  
PARTS  
ESPLOSO  
P. 323

MOTORES / ENGINES / MOTORI  
5.0FIP  
5.8FIP, FII, FSI

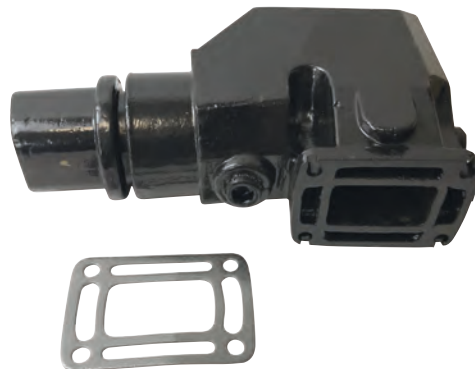

**EXTENSORES DE ESCAPE  
EXHAUST EXTENSOR  
PROLUNGA SCARICO**

Ref.	R.O. OEM
RM3854874	3854874

MOTORES / ENGINES / MOTORI  
4.3GL, GXI, OSI, GS, GI



Ref.	R.O. OEM
RM3863189	3863189

MOTORES / ENGINES / MOTORI  
V6 - V8





**CUERNOS DE ESCAPE SX  
EXHAUST TUBO SX  
CORNA DI ESCARICO SX**

Ref.	R.O. OEM
RM3858873	3858873 3850796 3853915 3855281 3850794



**RISER 6''  
(MAR061 & MAR501)**

Ref.	R.O. OEM
REC3842853	3842853



328

**CODOS ESCAPE  
EXHAUST ELBOWS  
GOMITI SCARICO**



Ref.	R.O. OEM	FUELLE BELLOW CUFFIA
HGE5261	845261 843217	RM843228

**MOTORES / ENGINES / MOTORI**  
TMD30A TMD40A, B, C  
TAMD30A TAMD40A, B  
AQAD30A AQAD40A, B



Ref.	R.O. OEM	FUELLE BELLOW CUFFIA
MAR963	859963	RM858955 CEF500530

**MOTORES / ENGINES / MOTORI**  
31 & 41 (antiguo / old model / vecchio)  
TMD, TAMD, AQ, AD, MD



VOLVO

Ref.	R.O. OEM
HGE5528	845528

**MOTORES / ENGINES / MOTORI**  
TAMD40A, B  
AQAD40A, B  
TMD40B, C

Se instala en codo HGE5261 o inverter MS3A/B  
Installed in elbow HGE5261 or inverter MS3A/B  
Installato nel gomito HGE5261 o inverter MS3A/B



Ref.	R.O. OEM	FUELLE BELLOW CUFFIA
MAR289	861289	RM860396

**MOTORES / ENGINES / MOTORI**  
32, 42, 43, 44, 300  
31 & 41 (modernos / new / moderno) DS



Ref.	R.O. OEM	JUNTA GASKET GUARNIZIONE
RM840690	840690	REC840902

**MOTORES / ENGINES / MOTORI**  
2001, B, AG, BG  
2002, B, AG, BG  
2003, B



Ref.	R.O. OEM	JUNTA GASKET GUARNIZIONE
MAR906 RM861906	861906 21190094	REC861907

**MOTORES / ENGINES / MOTORI**

MD2010A, B, C, D  
MD2020A, B, C, D  
MD2030A, B, C, D  
MD2040C, D  
D1-13, 20, 30  
D2-40



Ref.	R.O. OEM	JUNTA GASKET GUARNIZIONE
MAR345	21424345 3589544 861574 859865	REC888596

**MOTORES / ENGINES / MOTORI**

D2-50, 55  
MD22



Ref.	R.O. OEM
REC3884701 MAR701 HGE1640	3884701 3583856

**MOTORES / ENGINES / MOTORI**

D4 (180-300)



Ref.	R.O. OEM
HGE1502	22948847 22671214 21700014

**MOTORES / ENGINES / MOTORI**

D6 (280-435)



**PIPA CONEXIÓN PARA CODOS 3582512 & MAR345  
CONNECTOR FOR ELBOW 3582512 & MAR345  
INNESTI PER GOMITI 358512 E MAR345**

Ref.	R.O. OEM
REC859836	859836 3587410



**PIPA CONEXIÓN PARA CODOS D4 & D6  
CONNECTOR FOR ELBOW D4 & D6  
INNESTI PER GOMITI D4 E D6**

Ref.	R.O. OEM
REC21450768	21450768 3819016 3583915



**MOTORES / ENGINES / MOTORI**

D4  
D6

**CODO ESCAPE INOX  
STAINLESS STEEL ELBOW  
GOMITO SCARICO INOX**

Ref.	R.O. OEM
SED3091000	845261

**MOTORES / ENGINES / MOTORI**

30 & 40

(Sin soporte / without mount / senza supporto)



Ref.	R.O. OEM
SED3091100	859963

**MOTORES / ENGINES / MOTORI**

31 & 41

(Sin soporte / without mount / senza supporto)



Ref.	R.O. OEM
SED3091200	861289 860656

**MOTORES / ENGINES / MOTORI**

KAD32P

D5

31, 41, 42, 43, 44  
300



Ref.	R.O. OEM
SED3091400	3830988
	3826841
	865545
	3829668

**MOTORES / ENGINES / MOTORI**  
TAMD63 P-A  
D71, 72, 73, 74, 7A, 7C  
TAMD73 P-A, 61, 103



Ref.	R.O. OEM
SED3091500	3884701
	3583856

**MOTORES / ENGINES / MOTORI**  
D4



Ref.	R.O. OEM
SED3091600	21684825
	3841510
	22948844
	3587159
	22671213

**MOTORES / ENGINES / MOTORI**  
D6  
AQ & IPS



Ref.	R.O. OEM	JUNTA GASKET GUARNIZIONE
SED3090900	861906	REC861907
	21190094	

**MOTORES / ENGINES / MOTORI**  
MD2010, 2020, 2030, 2040  
D1-13, -20, -30  
D2-40



**ABRAZADERA ESCAPE  
EXHAUST CLAMP  
FASCETTA SCARICO**

Ref.	R.O. OEM
RM21325765	21325765
	842993

**MOTORES / ENGINES / MOTORI**  
30, 31, 32, 40, 41, 42, 43, 44, 300, D4



**COLECTORES ADMISIÓN  
INTAKE MANIFOLD  
COLLETTORE ASPIRAZIONE**

Ref.	R.O. OEM	TORNILLOS SCREW VITI
MP425036	3855806	8

**MOTORES / ENGINES / MOTORI**  
GM 262, 4.3 (V6)  
VORTEC (4 bbl)  
Hierro / Iron / In ghisa  
(1993+)



Ref.	R.O. OEM	TORNILLOS SCREW VITI
MP425024	3855805	8

**MOTORES / ENGINES / MOTORI**  
GM 262, 4.3 (V6)  
VORTEC (2 bbl)  
Hierro / Iron / In ghisa  
(1993+)



Ref.	R.O. OEM	TORNILLOS SCREW VITI
MP425113	3854100	16

**MOTORES / ENGINES / MOTORI**  
740A, B  
7.4 GLP



## GUÍA CODO ESCAPE EXHAUST ELBOW APPLICATION GUIDA GOMITO SCARICO

MOTORES ENGINES MOTORI	CODO ELBOW GOMITO	R.O. OEM	CODO INOX. ELBOW SS GOMITO INOX.	R.O. OEM	JUNTA GASKET GUARNIZ.	R.O. OEM	ANILLO O-RING PARAOILIO	R.O. OEM	ABARZADERA TURBO TURBO CLAMP FASCETTA TURBO	R.O. OEM	CONECTOR CONNECTOR CONNETTORE	R.O. OEM
TMD30A TAMD30A AQAD30A TMD40A, B, C TAMD40A, B AQD40A AQAD40A, B	HGE5261	845261	SED3091000	845261	REC859011	859011			RM21325765	842993	HGE5528 Solo modelos 40 Only 40 models Solo modelli 40	845528
TMD31A, B, D, L-A, P-A TAMD31A, B, D, L-A, M-A AQAD31A AD31, B MD31A TAMD41A, B, D, H-A, H-B, P-A, L-A, M-A TMD41A, B, D, L-A D41A, B AD41A, B, D AQAD41A	MAR963	859963	SED3091100	859963	REC859002	859002	REC842913	842913	RM21325765	842993		
AD31B, D-A, L-A, P-A, XD KAD32P D41B, D AD41B, D, L-A, P-A KAMD42A, P-A KAD42A, P-A TAMD42WJ-A KAMD43P-A KAD43P-A KAMD44P-A, P-C KAD44P, P-B, P-C KAD300-A KAMD300-A D5A-T, -TA D5A-B TA	MAR289	861289	SED3091200	861289	REC859002	859002	REC842913	842913	RM21325765	842993		
TAMD72WJ-A, P-A TAMD63L-A, P-A TAMD74C-A, C-B, L-A, L-B, P-A, P-B TAMD75P-A TAMD71A, B TAMD73P-A, WJ-A, TAMD72A TAMD61A TAMD62A TAMD103A D7A-T, A-TA, A-B TA, C-TA, C-B TA D4-180I-B, I-C, I-D, I-E D4-210A-A, A-B, I-A, I-B D4-225A-A-C, A-D, A-E, I-B, I-C, I-D, I-E D4-260A-A, A-B, A-C, A-D, A-E, D-B, D-C, D-D, D-E, I-A, I-B, I-C, I-D, I-E D4-300A-A, A-C, A-D, A-E, D-A, D-C, D-E, D-DI-A, I-C, I-D, I-E D4-300-D-A, D-C, D-E, D-E (IPS) D6-280A-A, A-B, A-C, A-D, A-E D6-300A-F, D-F D6-310A-A, A-B, A-C, A-D, A-E, D-B, D-C, D-D, D-E D6-330A-B, A-C, A-D, A-E, A-F, D-B, D-C, D-D, D-E, D-F D6-350A-A, A-B D6-370A-B, A-C, A-D, A-E, A-F, D-A, D-B, D-C, D-D, D-E, D-F D6-400A-F D6-435D-F			SED3091400	3830988								
D4-260A-A, A-B, A-C, A-D, A-E, D-B, D-C, D-D, D-E, I-A, I-B, I-C, I-D, I-E D4-300A-A, A-C, A-D, A-E, D-A, D-C, D-E, D-DI-A, I-C, I-D, I-E D4-300-D-A, D-C, D-E, D-E (IPS) D6-280A-A, A-B, A-C, A-D, A-E D6-300A-F, D-F D6-310A-A, A-B, A-C, A-D, A-E, D-B, D-C, D-D, D-E D6-330A-B, A-C, A-D, A-E, A-F, D-B, D-C, D-D, D-E, D-F D6-350A-A, A-B D6-370A-B, A-C, A-D, A-E, A-F, D-A, D-B, D-C, D-D, D-E, D-F D6-400A-F D6-435D-F	REC3884701	3884701	SED3091500	3884701					RM21325765	842993	REC21450768	21450768
D4-300-D-A, D-C, D-E, D-E (IPS) D6-280A-A, A-B, A-C, A-D, A-E D6-300A-F, D-F D6-310A-A, A-B, A-C, A-D, A-E, D-B, D-C, D-D, D-E D6-330A-B, A-C, A-D, A-E, A-F, D-B, D-C, D-D, D-E, D-F D6-350A-A, A-B D6-370A-B, A-C, A-D, A-E, A-F, D-A, D-B, D-C, D-D, D-E, D-F D6-400A-F D6-435D-F			SED3091600	21684825							REC21450768	21450768
2001, AG, B, BG 2002, AG, B, BG 2003, B	RM840690	840690			REC840902	840902	REC418445	418445				
MD2010A,B,-C,-D MD2020A,B,-C,-D MD2030A,B,-C,-D MD2040A,B,-C,-D D1-13, 13B, 13F D1-20, 20B, 20F D1-30, 30B, 30F D1-40, 40B, 40F	MAR906 RM861906	861906	SED3090900	861906	REC861907	861907						
D2-55A, B, C, D, E, F D2-50F MD22A, L-A, L-B, P-B	MAR345	21424345			RM859834 REC888596	859834 888596					REC859836	859836

# CARCASA Y ENFRIADOR DE ACEITE OIL COOLER & HOUSING CARCASSA E SCAMBIATORE OLIO

## ENFRIADOR COOLER FASCIO TUBIERO

Ref.	R.O. OEM			
SED3094100	876552	Latón	Brass	Bronzo

MOTORES / ENGINES / MOTORI  
30, 31, 40, 41 & 42

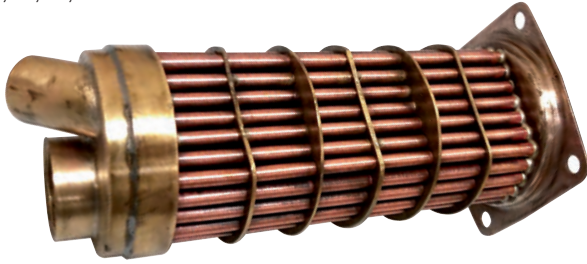

## CARCASA HOUSING CARCASSA

Ref.	R.O. OEM			
SED3094200		Acero inox. AISI316	Stainless steel AISI316	Aciaccio inox AISI316
RECOILCOOLER		Aluminio	Aluminium	Alluminio

MOTORES / ENGINES / MOTORI  
30, 31, 40, 41 & 42



RECOILCOOLER

SED3094200

# BOMBA DE CIRCULACIÓN BLOQUE BLOCK CIRCULATING PUMP POMPA DI RICIRCOLO DI BLOCCO

## BOMBAS PUMPS POMPE



Ref.	R.O. OEM
REC271975	271975 1275148 3547560

MOTORES / ENGINES / MOTORI  
131A, B, C, D      230A, B  
151A, B, C      250A, B  
171A, C      251A



Ref.	R.O. OEM
REC3587508	3587508 828023

MOTORES / ENGINES / MOTORI  
140A      125A  
120B      145A



Ref.	R.O. OEM
PH600-0004	3858340 3854017

MOTORES / ENGINES / MOTORI  
3.0L



Ref.	R.O. OEM
REC879194401	21124846

MOTORES / ENGINES / MOTORI

V6 (bloque sin / block without / blocco senza bypass)  
4.3L-J, GL-JF, GXI225-R, GI200-R, GXIE225-R, GXIE-M, GXIE-P, GXIE-Q,  
GXI-J, GXI-JF, OSI-V, OSI-JF, GXI-P, GXI-Q  
(2008+)



Ref.	R.O. OEM
PH600-0005	3853850

MOTORES / ENGINES / MOTORI

V6 & V8 (bloque pequeño / small block / blocco piccolo)  
Excepto / Except / Eccetto:  
4.3L-J, GL-JF, GXI225-R, GI200-R, GXIE225-R, GXIE-M, GXIE-P,  
GXIE-Q, GXI-J, GXI-JF, OSI-V, OSI-JF, GXI-P, GXI-Q  
(-2007)



Ref.	R.O. OEM
PH600-0003	3861341

**MOTORES / ENGINES / MOTORI**  
GM 8.1L



Ref.	R.O. OEM
PH600-0002	3855991 856609 3854118

**MOTORES / ENGINES / MOTORI**  
7.4L  
8.2L



Ref.	R.O. OEM
PH600-0006	3853796

**MOTORES / ENGINES / MOTORI**  
V8 Ford, 302 & 351



**JUNTAS BOMBA AGUA**  
**SEA WATER GASKET**  
**GUARNIZIONE POMPA DELL'ACQUA**



Ref.	R.O. OEM	BOMBA PUMP POMPA
REC27-803192A2		PH600-0002

**MOTORES / ENGINES / MOTORI**  
740, 7.4, 8.2L

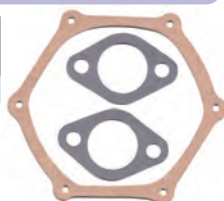

Ref.	R.O. OEM	BOMBA PUMP POMPA
REC27-56880		PH600-0006

**MOTORES / ENGINES / MOTORI**  
Ford V8 (302, 351)

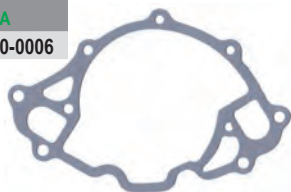

Ref.	R.O. OEM	BOMBA PUMP POMPA
REC27-33956	3853342	PH600-0004

**MOTORES / ENGINES / MOTORI**  
4 & 6 Cyl.



Ref.	R.O. OEM	BOMBA PUMP POMPA
REC27-34897	3852477	PH600-0005 REC879194401

**MOTORES / ENGINES / MOTORI**  
GM V6 & V8 Bloque pequeño / Small block / blocco piccolo



Ref.	R.O. OEM	BOMBA PUMP POMPA
REC27-49110	3853361	PH600-0002

**MOTORES / ENGINES / MOTORI**  
V-8 Bloque grande / big block / blocco grande



Ref.	R.O. OEM
REC22014	

**MOTORES / ENGINES / MOTORI**  
AQ120B, 125A, 140A, 145A  
BB140A, 145A



Ref.	R.O. OEM
REC22038	

**MOTORES / ENGINES / MOTORI**  
AQ125B, 145B



Ref.	R.O. OEM
REC22039	

**MOTORES / ENGINES / MOTORI**  
AQ131A, B, C, D  
AQ151A, B, C  
AQ171A, C  
230A, 250A, 251A



Ref.	R.O. OEM
REC22013	

**MOTORES / ENGINES / MOTORI**  
AQ165A  
BB165A  
AQ170A, B, C  
BB170A, B, C



**BOMBAS PUMPS POMPE**



Ref.	R.O. OEM
REC23059414	23059414

**MOTORES / ENGINES / MOTORI**  
D31, 41, 42, 43, 44, 300  
KAD32P



**NEW**

**KIT REPARACIÓN BOMBA  
WATER PUMP REPAIR KIT  
KIT RIPARAZIONE POMPA**



Ref.	R.O. OEM
REC3801404	3801404 3801636 30751022 31293668

**MOTORES / ENGINES / MOTORI**  
D3



Ref.	R.O. OEM
REC22126	

**MOTORES / ENGINES / MOTORI**  
MD21B  
AQD21B  
(Versión moderna / Late version with pipe  
cooler / Versione moderna)

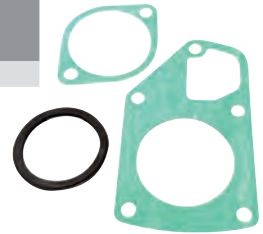

Ref.	R.O. OEM
REC3818912	3818912

**MOTORES / ENGINES / MOTORI**  
D4  
D6



**JUNTAS BOMBA AGUA  
SEA WATER GASKET  
GUARNIZIONE POMPA DELL'ACQUA**



Ref.	R.O. OEM
REC876793	876793 876560



**MOTORES / ENGINES / MOTORI**  
D30, 31, 32  
TD30A  
AQAD30A  
AQAD31A  
MD30A  
TAMD30A  
TMD30A

TMD31A, L-A  
TD31ACE  
AD31, L-A, P-A  
TAMD31-L-A, M-A,  
P-A, S-A, A  
KAD32P



Ref.	R.O. OEM	PARA BOMBA FOR PUMP PER POMPA
REC30677767	30677767	REC3801404

**MOTORES / ENGINES / MOTORI**  
D3



**MANGUITO  
HOSE  
MANICOTTO**

Ref.	R.O. OEM
RM3852289	3852289

**MOTORES / ENGINES / MOTORI**  
3.0 (1994-98)  
MD, HU, LK, NC



Ref.	R.O. OEM
REC876794	876794 876544



**MOTORES / ENGINES / MOTORI**  
D40, 41, 41A,  
41L-A, 42, 43,  
44, 300  
TD40A  
MD40A  
TMD40A, B, C  
AQD40A  
TAMD40A, B  
AQAD40A, B  
TMD41A, L-A  
TAMD41A  
AD41A, L-A  
TAMD41H-A, H-B, L-A,  
M-A, P-A  
TAMD42WJ-A, B  
KAD42A, P-A  
KAMD42A, P-A

KAD43P-A  
KAMD43P-A  
KAD44P-A, P-B, P-C  
KAMD44P-A, P-B, P-C  
KAD300  
KAMD300

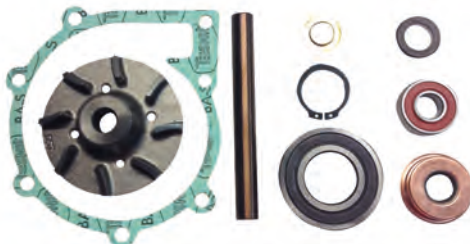

Ref.	R.O. OEM
RM3857391	3857391

**MOTORES / ENGINES / MOTORI**  
3.0 (1998-11)  
BY, EF, WT



Ref.	R.O. OEM
RM3852288	3852288

**MOTORES / ENGINES / MOTORI**  
V6 & V8  
4.3, 5.0, 5.7



Ref.	R.O. OEM
REC22125	

**MOTORES / ENGINES / MOTORI**  
MD21A  
AQD21A  
MD21B  
AQD21B  
(Versiones nuevas / Early version /  
Nuova versione)

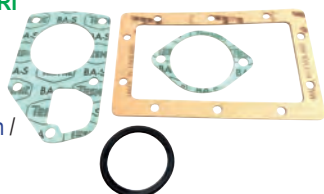

Ref.	R.O. OEM
REC3862523	3862523

**MOTORES / ENGINES / MOTORI**  
V6 & V8  
(Nuevos modelos / New models / Nuovi  
modelli)



## GUÍA BOMBA CIRCULACIÓN WATER CIRCULATING PUMP APPLICATION GUIDA POMPA DI RICIRCOLO



MOTORES ENGINES MOTORI	BOMBA PUMP POMPA	R.O. OEM	JUNTA BOMBA GASKET PUMP GUARNIZIONE POMPA	R.O. OEM	CUERPO THERMOSTAT HOUSING CORPI THERMOSTATO	R.O. OEM	JUNTA CUERPO T. GASKET TH. HOUSING GUARNI. CORPI T.	R.O. OEM	MANGUITO CUERPO-BOMBA HOSE HOUSING-PUMP MANICOTTO CORPO-POMPA	R.O. OEM
AQ131A, B, C, D AQ115A, B, C AQ171A, C	REC271975	271975								
B21 B23 AQ120B AQ125A	REC3587508	3587508								
3.0GLMMDA, GSPMDA, GSMHUB, GSPHUB, GSMNCA, GSPNCA, GSMNCS, GSPNCS, GSMLKD, GSPLKG	PH600-0004	3858340	REC27-33956	3853342	BAOMC29-910303	3854254	REC27-8146801	3852096	RM3852289	3852289
3.0GSP-A, -B, -C WTR, WTS, BYCCE, EFS GSM-A, -B, -C, WTR, WTS, BYMCE GLP-A, -B, -C, -D, -E, -J, -N GLM-A, -B, -C	PH600-0004	3858340	REC27-33956	3853342			REC27-8146801	3852096	RM3857391	3857391
4.3GXIE-M, GL-P, GL-J, GL-JF, GXI-J, GXI-JF, GXI-P, GXI-Q, GXIE-P, GXIE-Q, GXI-225-R, GI-200-R, GXIE-225-R, Osi-J, Osi-JF	REC879194401	21124846	REC27-34897	3852477			REC27-33918	3852111	REC3862523	3862526
V6-200-A V6-225-A, -E-A V8 (bloque pequeño / small block / blocco piccolo) & V6 Excepto / Except / Eccetto:										
4.3GXIE-M, GL-P, GL-J, GL-JF, GXI-J, GXI-JF, GXI-P, GXI-Q, GXIE-P, GXIE-Q, GXI-225-R, GI-200-R, GXIE-225-R, Osi-J, Osi-JF	PH600-0005	3853850	REC27-34897	3852477	REC3850360	3850360	REC27-33918	3852111	RM3852288	3852288
V6-200-A V6-225-A, -E-A										
8.1 GIE-P, -J, -K, -M, -JF, -KF, -MF GXIE-P, -J, -K, -M, -JF, -KF, -MF GICE-P, -Q IPSC-E, -PF, -Q, -JF, -MF IPSE-JF GI-A, -B, -C, -D, -E, -F, -J, -JF, -G, -H, -J, -JF, -EF, -FF, -HF GSI-A GXI-A, -B, -C, -D, -E, -F, -G, -J, -JF, -DF, -EF, -FF, -GF GII-A, -B, -C, -D, -E, -G, -H GSI-A GXI-A, -B, -C, -D, -E, -F, -G OSI-A, -B, -C, -D, -J, -AF, -BF, -CF, -DF, -JF OSI-E, -J, -JF GIC-400-J, -JF, -Q	PH600-0003	3861341					REC27-33918	3852111		
740A, B 7.4GLPMDA, GLPMDM, GLIMDA, GLIMDM, GLPHUS, GIPHUSCE, GSIX- HUS, GLIHUB, GIIHUBCE, GLPNCS, GLPNCB, GIINCCCE, GIPNCBCE, GIPNCSCE, GLINCC, GLINCS, GSI- INCC, GSIXNCB, GLPNCA, GLPNCM, GIINCSCE, GIPNCACE, GIPNCMCE, GLINCS, GSIINCS, GSIXNCMGLPKD, GLPLKE, GIPLKDCE, GIPLKECE	PH600-0002	3855991	REC27-49110	3853361			REC27-33918	3852111		
8.2GLPMDA, GLPMDM, GLIMDA, GLIMDM, GSIXNCB										
5.0FI, FL 5.8FI, FL (Ford 302 & 351)	PH600-0006	3853796	REC27-56880	3852824	REC3850360	3850360	REC27-33918	3852111		

## GUÍA BOMBA CIRCULACIÓN WATER CIRCULATING PUMP APPLICATION GUIDA POMPA DI RICIRCOLO



MOTORES ENGINES MOTORI	BOMBA PUMP POMPA	R.O. OEM	JUNTA BOMBA GASKET PUMP GUARNIZIONE POMPA	R.O. OEM
D3-110I-B, I-C, I-D, I-E, I-F, I-G, I-H D3-130A-B, A-C, I-B, I-C D3-140A-D, A-E, A-F, A-G, A-H, I-E, I-F, I-G, I-H D3-150I-D, I-E, I-F, I-G, I-H D3-160A-B, A-C, I-B, I-C D3-170A-D, A-E, A-F, A-G, A-H, I-D, I-E, I-F, I-G, I-H D3-190A-B, A-C, I-B, I-C D3-200A-D, A-E, A-F, A-G, A-H, I-D, I-E, I-F, I-G, I-H D3-220A-D, A-E, A-F, A-G, A-H, I-D, I-E, I-F, I-G, I-H	REC3801404	3801404	REC30677767	30677767



# FILTRO DE AGUA SALADA SEA WATER FILTER FILTRO ACQUA SALATA

Nº	Ref.	R.O. OEM	Descripción	Description	Descrizione
1	RM829205	829205	TAPON DE PRESION	PRESSURE CAP	TAPPO
2	RM855410	855410	TAPA	COVER	COPERCHIO
3	RM855433	855433	TAPA DE PRESION	PRESSURE PLATE	TAPPO
4	RM855423	855423	JUNTA	GASKET	GUARNIZIONE
5	RM855409	855409	FILTRO	STRAINER	FILTRO
6	RM856100	856100	CAJA	STRAINER HOUSING	CORPO
7	RM855791	855791	CONECTOR	CONNECTOR	ATTACCO
8	RM856083	856083	CONECTOR	CONNECTION PIPE	ATTACCO
9	REC22037		KIT GOMAS	GASKET SET	KIT GOMMINI



**MOTORES / ENGINES / MOTORI**

230A, B  
250A, B  
251A  
AQ131A, B, C, D  
AQ151A, B, C, D  
AQ171A, C

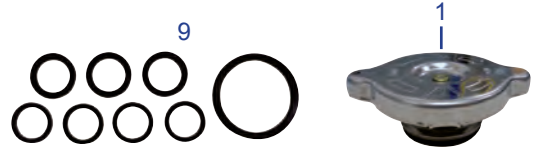

Ref.	R.O. OEM
REC3583840	3583840 21219693

**MOTORES / ENGINES / MOTORI**

2001, 2002, 2003, 2010, 2020, 2030, 2040  
MD  
AQD21, 30, 31, 41, D1, 2



**NEW**



Ref.	R.O. OEM
REC21655254	21655254
	21610728
	3594159
	3809093
	3594161
REC21880386	3809097
	3587046
	21880386
	21641712
	860631



**NEW**

**NEW**

Ref.	R.O. OEM
REC21457172	21457172
	3889148
	3809070
	3582986
	3809071
	3583338

**MOTORES / ENGINES / MOTORI**

D4 & D6 (con cola / with sterndrive / con piede)



**NEW**

**NEUTRA-SALT**

**NEW**

REC21687793  
REC21687796



# BOMBA ASPIRACIÓN AGUA MARINA RAW MARINE WATER PUMPS POMPE ASPIRAZIONE ACQUA MARINA

Ref.	R.O. OEM	GOMA TUBO RUBBER TUBE GOMMA TUBO	CENTRADOR CENTER CENTRATORE	IMPULSOR IMPELLER GIRANTE
JOH10-32621-2	855578 828026 855517	REC831622	REC831009	REC875575

## MOTORES / ENGINES / MOTORI

AQ120B AQ171A, C  
AQ125A, B AQ251C  
AQ131A, B, C, D AQ230A, B  
AQ140A AQ250A, B  
AQ145A, B BB140A  
AQ151A, B, C BB145A



Ref.	R.O. OEM	CENTRADOR CENTER CENTRATORE	IMPULSOR IMPELLER GIRANTE
JOH10-32058-1	831178	REC831009	REC875575

## MOTORES / ENGINES / MOTORI

AQ165A  
AQ170A, B, C  
MD21A MO 103387-9  
MD21B  
AQD21B, A  
BB165A  
BB170A, B, C

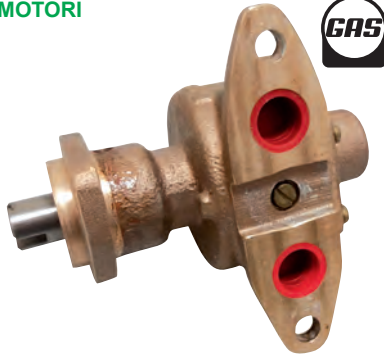

Ref.	R.O. OEM	CONSOLA CONSOLE TIRANTE	IMPULSOR IMPELLER GIRANTE
RM21212798	21212798 3812522	REC3817687	REC21213664

## MOTORES / ENGINES / MOTORI

3.0GLP-D, P-E, P-J, P-N



Ref.	R.O. OEM	CONSOLA CONSOLE TIRANTE	IMPULSOR IMPELLER GIRANTE
RM21212801	21212801 21131568	REC3817687	REC21213664

## MOTORES / ENGINES / MOTORI

3.0GXIC-J, GXI-J



Ref.	R.O. OEM	TOPE BOMBA RUBBER STOP TAPO DI GOMMA	IMPULSOR IMPELLER GIRANTE
RM21214595	21214595 3812696 3862485 3861417	REC3857954	REC21213660

## MOTORES / ENGINES / MOTORI

3.0GLP-A, B, C  
3.0GLM-A, B, C  
3.0GSP-A, B, C  
3.0GSM-A, B, C



Ref.	R.O. OEM	CONSOLA CONSOLE TIRANTE	TOPE BOMBA RUBBER STOP TAPO DI GOMMA	IMPULSOR IMPELLER GIRANTE
REC21214599	21214599 3812693 3862482 3857202	REC3812240	REC3857954	REC21213660

## MOTORES / ENGINES / MOTORI

3.0GSMEFS, GSPEFS  
4.3GXI-C, GXI-CF, GXI-D,  
GXI-DF, GXI-SI, GXI-E,  
GXI-EF, OSI-E, OSI-EF  
5.0GXI-C, GXI-CF, GXI-D,  
SI-C, SI-CF, SI-D, SI-DF,  
SI-E, GXI-EF, DSI-E  
5.7GI, GXI, OSI, SXI, GXIL



Ref.	R.O. OEM	IMPULSOR IMPELLER GIRANTE
SHEG9903	3857794 3851982 3855079 3852399	JOH09-1027B

## MOTORES / ENGINES / MOTORI

3.0GL, GS  
4.3GLP, GS, GI  
5.0GL, GI, GS  
5.7GL, GI  
7.4GL, GI, GS  
8.2GSI

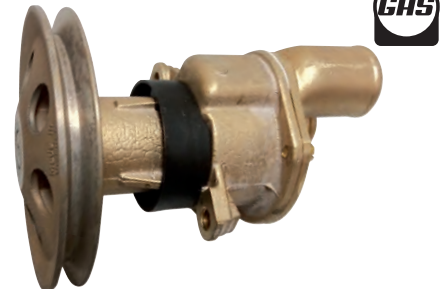

Ref.	R.O. OEM	POLEA PULEY PULLEGIA	IMPULSOR IMPELLER GIRANTE
SHEG9901	3858847 3851623 3852398 3855778	165 mm	JOH09-1027B

## MOTORES / ENGINES / MOTORI

4.3GLM, GLP, GS, GI  
5.0 Ford FI, FL, FS  
5.7GI, GL  
5.8 Ford FI, FL, FS  
7.4GL, GI  
8.2GL

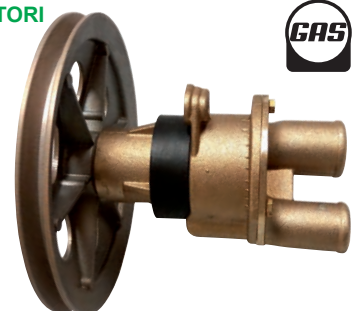

Ref.	R.O. OEM	BUJE DE GOMA RUBBER HUB BOCCOLA IN GOMMA	IMPULSOR IMPELLER GIRANTE
REC3860703	3860703 856513	RM826422	CEF500104

**MOTORES / ENGINES / MOTORI**  
V6 & V8



Ref.	R.O. OEM	IMPULSOR IMPELLER GIRANTE
REC21212800	21212800 3812518	CEF500178G

**MOTORES / ENGINES / MOTORI**  
8.1 GIE-P, FXIE-P, CICE-P/Q, G, H  
8.1 IPS  
8.1 OSI-C/CF, D, DF  
8.1 GI-G, H



Ref.	R.O. OEM	TOPE BOMBA RUBBER STOP TAPO DI GOMMA	IMPULSOR IMPELLER GIRANTE
RM21214596	21214596 3812697 3862487 3858229	REC3857954	REC21213660

**MOTORES / ENGINES / MOTORI**  
4.3GL-A, GL-B, GL-C, GL-D, GLP  
5.0GL-A, GL-B, GL-C, GL-D, GL-E, GLP  
5.7GL-A, GL-B, GL-C, GL-D, GL-E



Ref.	R.O. OEM	TOPE BOMBA RUBBER STOP TAPO DI GOMMA	IMPULSOR IMPELLER GIRANTE
REC21214601	21214601 3812695 3862484 3860795	REC3857954	JOH09-1027B

**MOTORES / ENGINES / MOTORI**  
8.1



Ref.	R.O. OEM	CONSOLA CONSOLE TIRANTE	IMPULSOR IMPELLER GIRANTE
RM21255090	21255090 3812520	REC3812240	REC21213664

**MOTORES / ENGINES / MOTORI**  
4.3GL-E, GL-EF  
5.0GL-F, GL-FF



Ref.	R.O. OEM	TÓRICA BLOQUE O-RING BLOCK O-RING BLOCCO	IMPULSOR IMPELLER GIRANTE
JOH10-35098-3	829895	REC975672	REC3586496

**MOTORES / ENGINES / MOTORI**  
AQ60, 90, 95, 100, 105, 110, 115, 120A, 130  
MB18, 20  
MD3B, 17C, D  
Sin rosca / without thread / senza filetto



Ref.	R.O. OEM	CONSOLA CONSOLE TIRANTE	IMPULSOR IMPELLER GIRANTE
REC21212799	21212799 3812519	REC3817688	REC21213664

**MOTORES / ENGINES / MOTORI**  
4.3GL-G, GL-GF, GXI-F, OSI-F, GXIE-M, GL-P,  
GXI-P, GXI-Q, GXI-GF, OSI-GF, GXI-G, OSI-G  
5.0GL-M, GL-HI, GXI-F, GXI-FF, OSI-FF, GXI-G, GXI-GF,  
OSI-G, OSI-GF, GIF-FF, GXI-G,  
GXI-GLI, OSI-E, OSI-EF,  
OSI-GF, SXI-G, SXI-GF, GI-F,  
GXIL-G, GIL-G, GXIL-H

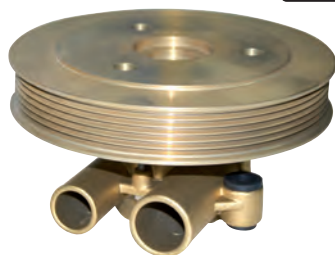

Ref.	R.O. OEM	GOMA TUBO RUBBER TUBE GOMMA TUBO	TÓRICA BLOQUE O-RING BLOCK O-RING BLOCCO	IMPULSOR IMPELLER GIRANTE
JOH10-24707-01	840557 861009	REC829714	REC925093	REC3586496

**MOTORES / ENGINES / MOTORI**  
2001, B, AG, BG  
2002, B, D, AG, BG  
2003, B, D, AG, BG



Ref.	R.O. OEM	IMPULSOR IMPELLER GIRANTE
JOH10-35157-1	858065	REC3586496
	840076	
	833415	
	833883	
	807368	

**MOTORES / ENGINES / MOTORI**

MD11D, C  
MD6A, B  
MD7A, B  
MD1B, 2B  
AQD2B  
MD5A, B, C  
MB10A  
Sin rosca  
without thread  
senza filetto



Ref.	R.O. OEM	IMPULSOR IMPELLER GIRANTE
JOH10-35157-3	807368	REC3586496
	833415	
	833522	
	833883	

**MOTORES / ENGINES / MOTORI**

MD11D, C  
MD6A, B  
MD7A, B  
MD1B, 2B  
AQD2B  
MD5A, B, C  
MB10A  
Con rosca  
with thread  
con filetto



Ref.	R.O. OEM	GOMA TUBO RUBBER TUBE GOMMA TUBO	TÓRICA BLOQUE O-RING BLOCK O-RING BLOCCO	IMPULSOR IMPELLER GIRANTE
JOH10-24268-4	858150	REC418411	REC925093	JOH09-1027B

**MOTORES / ENGINES / MOTORI**

2003T, TB

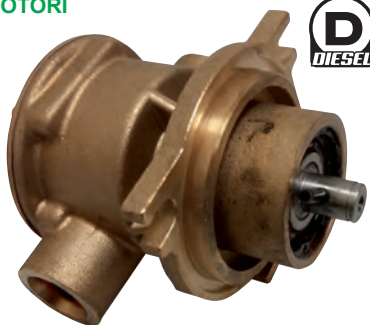

Ref.	R.O. OEM	CENTRADOR CENTER CENTRATORE	TÓRICA BLOQUE O-RING BLOCK O-RING BLOCCO	IMPULSOR IMPELLER GIRANTE
JOH10-24061-3	842843	REC829433	RM968971	REC3841697

**MOTORES / ENGINES / MOTORI**

TMD30A  
TAMD30A  
AQAD30A  
AQD40A  
MD40A  
TMD40A, B, C,  
(Modelos antiguos  
old style  
modello vecchio)



Ref.	R.O. OEM	TÓRICA BLOQUE O-RING BLOCK O-RING BLOCCO	IMPULSOR IMPELLER GIRANTE
JOH10-24130-3	838522 844971	RM968971	JOH09-1028B

**MOTORES / ENGINES / MOTORI**

TAMD40A, B  
AQAD40A, B  
(Modelos antiguos / old style /  
vecchio)



Ref.	R.O. OEM	CENTRADOR CENTER CENTRATORE	TÓRICA BLOQUE O-RING BLOCK O-RING BLOCCO	IMPULSOR IMPELLER GIRANTE
JOH10-24277-3	858469	REC858467	RM968971	REC3841697

**MOTORES / ENGINES / MOTORI**

TMD31A, B  
TMD41A, B  
TAMD31A, B  
AQAD41A, B  
AQAD31A  
D41A, B  
AD31A, B  
(Modelos antiguos  
old style  
modello vecchio)



Ref.	R.O. OEM	CENTRADOR CENTER CENTRATORE	TÓRICA BLOQUE O-RING BLOCK O-RING BLOCCO	IMPULSOR IMPELLER GIRANTE
REC3583115	3583115	REC858467	RM968971	REC3841697
	860629			
	3581558			
	860827			

**MOTORES / ENGINES / MOTORI**

31, 32, 40, 41, 42, 43, 44, 300  
Para manguitos fijados con abrazaderas.  
For hose connectors with clamps.  
Modello pompa de montare con manicotti  
bloccati con fascette



Ref.	R.O. OEM
REC3829311	3829311
	846354

**MOTORES / ENGINES / MOTORI**

TAMD61A, B  
SN (-1101014435 / XXXXX:A)  
TMD100C, 102A, 122A, 121C, 120B  
TAMD102A, 102C, 121C, 121D

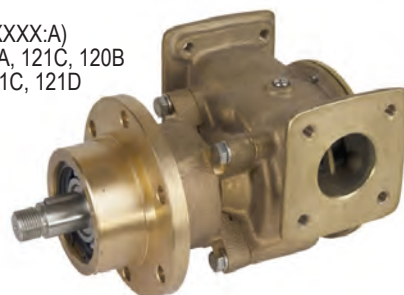

Ref.	R.O. OEM
REC3837935	3837935
	3825493
	876809
	863437

**MOTORES / ENGINES / MOTORI**  
TAMD162A, B, C, C-B, C-C  
TAMD163A-A, P-A  
TAMD165A-A, C-A, P-A



Ref.	R.O. OEM
REC3829313	3829313
	3829312
	866396
	845189

**MOTORES / ENGINES / MOTORI**  
TAMD102A, 102D, 103A, 120B, 122A, 122C,  
122D, 122P-A, 122P-B, 122P-C



Ref.	R.O. OEM	TÓRICA BLOQUE O-RING BLOCK O-RING BLOCCO	IMPULSOR IMPELLER GIRANTE
JOH10-22335-3	842275	REC967344	REC3841697

**MOTORES / ENGINES / MOTORI**  
TAMD60A, B, C

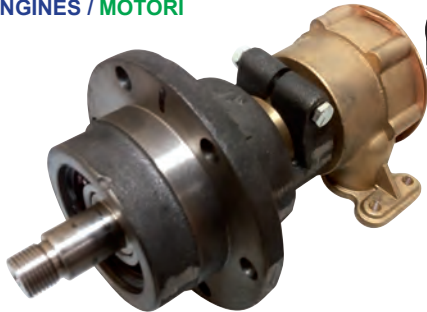

Ref.	R.O. OEM	IMPULSOR IMPELLER GIRANTE
REC3593655	3593655	REC3593659
	3580945	
	3580222	
	3580223	
	3580910	
	3580920	

**MOTORES / ENGINES / MOTORI**  
D1-30, B, F  
D2-40, B, F  
MD2030A, B, C, D  
MD2040A, B, C, D



Ref.	R.O. OEM	IMPULSOR IMPELLER GIRANTE
REC3593654	3593654	REC3593659
	3580064	
	3580944	
	3580900	

**MOTORES / ENGINES / MOTORI**  
D1-13, B, F  
D1-20, B, F  
MD2010A, B, C, D  
MD2020A, B, C, D



Ref.	R.O. OEM	IMPULSOR IMPELLER GIRANTE
REC3583089	3583089	JOH09-1027B

**MOTORES / ENGINES / MOTORI**  
D2-50F  
D2-55B, C, D, E, F  
D2-60F  
D2-75B, C, F



Ref.	R.O. OEM	IMPULSOR IMPELLER GIRANTE
REC21141637	21141637	JOH09-812B
	3593656	
	3884694	

**MOTORES / ENGINES / MOTORI**  
D3-110I-A, I-B, I-C  
D3-130A-A, I-A, I-B, A-B, A-C  
D3-160A-A, I-A, I-B, I-C, A-B, A-C  
D3-190I-B, I-C, A-B, A-C



Ref.	R.O. OEM	IMPULSOR IMPELLER GIRANTE
REC21379102	21379102	JOH09-812B
	21106041	

**MOTORES / ENGINES / MOTORI**  
D3-110 --> D3-220



Ref.	R.O. OEM	IMPULSOR IMPELLER GIRANTE
REC3584062	3584062	JAB17937-0001-P

**MOTORES / ENGINES / MOTORI**  
 D4-180I-B, I-C, I-D, I-E, I-F  
 D4-210A-A, I-A, I-B  
 D4-225A-C, A-D, I-B, I-C, I-D, I-E, I-F  
 D4-260A-A, A-B, A-C, A-D, D-B, D-C, D-D, I-A, I-B, I-C, I-D  
 D4-300A-A, A-C, A-D, D-A, D-C, D-D, I-A, I-C, I-D



**NEW** 

Ref.	R.O. OEM	IMPULSOR IMPELLER GIRANTE
REC21419374	21419374	REC3841697

**MOTORES / ENGINES / MOTORI**  
 D4-225A-E, A-F  
 D4-260A-E, A-F, D-E, D-F  
 D4-300A-E, A-F, D-E, D-F



**NEW** 

Ref.	R.O. OEM	IMPULSOR IMPELLER GIRANTE
REC3838288	3838288	REC3841697

**MOTORES / ENGINES / MOTORI**  
 D5A-T, A-TA, A-BTA  
 D7A-T, A-TA, A-BTA  
 D7C-TA, C-BTA



**NEW** 

Ref.	R.O. OEM	IMPULSOR IMPELLER GIRANTE
REC21419376	21419376	REC3887761

**MOTORES / ENGINES / MOTORI**  
 D6



**NEW** 

Ref.	R.O. OEM	IMPULSOR IMPELLER GIRANTE
REC21380890	21380890 3589907 3584063	REC3593573

**MOTORES / ENGINES / MOTORI**  
 D6

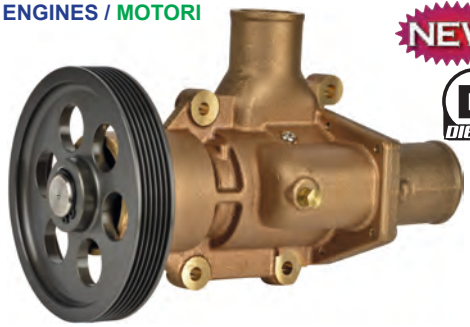



**NEW** 

**MOTORES CON SISTEMA IPS  
 IPS SYSTEM ENGINES  
 MOTORI CON SISTEMA IPS**

Ref.	R.O. OEM	IMPULSOR IMPELLER GIRANTE
REC21380886	21380886 3819485 3836314	JAB17018-0001

**MOTORES / ENGINES / MOTORI**  
 D9A  
 D11A



**NEW** 

Ref.	R.O. OEM	IMPULSOR IMPELLER GIRANTE
REC22063494	22063494	JAB17018-0001

**MOTORES / ENGINES / MOTORI**  
 D11B1-AMP  
 D11B2-AMP (IPS)



**NEW** 

Ref.	R.O. OEM	IMPULSOR IMPELLER GIRANTE
REC21219723	21219723	REC21730344

**MOTORES / ENGINES / MOTORI**  
 D11A-D (IPS)  
 D11A-C MP  
 D11B2-A MP



**NEW** 

Ref.	R.O. OEM	IMPULSOR IMPELLER GIRANTE
REC3838207	3838207 865295	JAB17938-0001-P

**MOTORES / ENGINES / MOTORI**  
D12D-A, D-B, D-C, C-A, D-F, D-E, D-G



Ref.	R.O. OEM	IMPULSOR IMPELLER GIRANTE
REC22905150	22905150 3886848	JAB17938-0001-P

**MOTORES / ENGINES / MOTORI**  
D13B, C



Ref.	R.O. OEM	IMPULSOR IMPELLER GIRANTE
REC22905155	22905155 3589104	JAB17938-0001-P

**MOTORES / ENGINES / MOTORI**  
D16C-DMH, AMH, BMH, CMH, AMG



**TOPE BOMBAS  
PUMP STOP  
ALETTA ARRESTO POMPE**

Ref.	R.O. OEM	BOMBAS PUMPS POMPE
REC3857954	3857954	REC21214599 REC21214601 RM21214596 RM21214595



**CONSOLAS PARA BOMBAS  
PUMPS CONSOLE  
TIRANTE PER POMPE**

Ref.	R.O. OEM	BOMBAS PUMPS POMPE
REC3812240	3812240	REC21212799



Ref.	R.O. OEM	BOMBAS PUMPS POMPE
REC3817687	3817687	RM21212798 RM21212801



**PARA BOMBAS E INTERCAMBIADORES DE CALOR  
FOR PUMPS AND HEAT EXCHANGERS  
PER POMPA E SCAMBIATORE DI CALORE**

Ref.	R.O. OEM	BOMBAS PUMPS POMPE
REC3817688	3817688	REC21212799 RM21255090



**COJINETE BOMBA  
WATER PUMP BEARING  
CUSCINETTO POMPA**

Cojinete (2 Piezas) para bomba en cigüeñal tapa de 4 tornillos  
Bearing (2 pcs) 4 bolt crankshaft cover  
Cuscinetto (2pz) per pompa albero motore, 4 vite nel coperchio

Ref.	R.O. OEM	<b>GAS</b>
REC183861	183861	

**MOTORES / ENGINES / MOTORI**

175A	271A, C	571A
200C, D, F	290A	572A
211A	311A, B	BB225A, AV, B, C
225C, D, F	430A, B	231B
231A, B	431A, B	255AV
255A, B	500A, B	260A, AV, B
260A	570A	



Ref.	R.O. OEM
RECV11010	861812 3578536 3884972 11010 6600756

**MOTORES / ENGINES / MOTORI**

2003T, B, TB  
D31, 32, 40, 41, 42 43, 44, 300



**TORNILLOS  
SCREWS  
VITI**

**6 TORNILLOS EN LA TAPA  
6 BOLT ON CAP  
6 VITI IN COPERCHIO**

Ref.	R.O. OEM
REC855728	855728

**MOTORES / ENGINES / MOTORI  
V6 & V8**

Ref.	R.O. OEM
REC840785	804693 803723 840785

**MOTORES / ENGINES / MOTORI  
AQ200D, 225D, 225B, 260A, 280A, 290  
MD1A, B, MD2D, B, MD3B, MD17C, A**



**4 TORNILLOS EN LA TAPA  
4 BOLT ON CAP  
4 VITI IN COPERCHIO**

Ref.	R.O. OEM
REC841693	841693

**MOTORES / ENGINES / MOTORI  
AQ175A, 200D, 211A, 225D, F  
V6 & V8**

Ref.	R.O. OEM
REC840384	833997 840384

**MOTORES / ENGINES / MOTORI  
MD11C**



**PESTAÑA DE SUJECCIÓN PARA BOMBAS CON COJINETE DE BOLA  
MOUNTING CLAMP FOR BALL BEARING PUMPS  
PIASTRA DI SUPPORTO PER POMPA CON CUSCNETTO A SFERE**

Ref.	R.O. OEM
REC833878	833878

**MOTORES / ENGINES / MOTORI  
AQ60, 90, 95, 100, 105, 110, 115, 120A, 130  
MD6A, B  
MD7A, B  
MD1B, 2B, 3B  
AQD2B  
MD11C, D  
MD17C, D  
MD20A, B, C**



**TAPA DEPÓSITO EXPANSIÓN  
EXPANSION DEPOSIT COVER  
COPERCHIO DEPOSITO ESPANSIONE**

Ref.	R.O. OEM
REC1674083	1674083
	1357775
	463828
	1674084
	3850064



**KIT RETENES Y JUNTAS BOMBA  
ASPIRACIÓN  
GASKET KITS FOR RAW  
WATER PUMPS  
KIT PARA OLIO E GUARNIZIONI  
POMPA ASPIRAZIONE**

Ref.	R.O. OEM	IMPULSOR IMPELLER GIRANTE
REC22042		REC3593659

**MOTORES / ENGINES / MOTORI  
AQ60, 90, 95, 100, 105A, 110, 115, 120A  
AQ130A, B, C, D  
MB18  
MB20A, B, C  
MD3B, 17C, D  
BB30, 100  
BB115, B, C**

Para bombas sin cojinete  
de bola  
For pumps without ball bearing  
Per pompe senza cuscinetto



Ref.	R.O. OEM	IMPULSOR IMPELLER GIRANTE
REC22009		REC3593659

**MOTORES / ENGINES / MOTORI  
AQ60F, 90, 95, 100, 105A, 110, 115, 120, 130  
MB18, 20  
MD3B, 17C, D  
BB30, 100,  
BB115B, C  
D1-13A, B, F  
D1-20A, B, F  
D2-40A, B**

Para bombas con cojinete de bola  
For pumps with ball bearing  
Per pompe con cuscinetto



Ref.	R.O. OEM	IMPULSOR IMPELLER GIRANTE
REC22047		REC875575

**MOTORES / ENGINES / MOTORI  
AQ165A  
AQ170A, B, C  
BB165A  
BB170A, B, C  
AQD21A, B  
MD21A MO (103387+)  
MD21B**



Ref.	R.O. OEM	IMPULSOR IMPELLER GIRANTE
REC22072		REC875575

**MOTORES / ENGINES / MOTORI  
AQ120B, 125, 131, 140, 145, 151, 171,  
230A, 250A, 251A**



Ref.	R.O. OEM	IMPULSOR IMPELLER GIRANTE
REC22053		REC3586494

**MOTORES / ENGINES / MOTORI  
MB10A  
D1A  
D2A  
MD1A, B  
AQD2A, B  
MD2, 2A, 2B, 6A**

Versiones nuevas con cojinete plano  
Early version with plain bearing  
Nuova versione con cuscinetto piano





Ref.	R.O. OEM	IMPULSOR IMPELLER GIRANTE
REC22054		REC3586494

**MOTORES / ENGINES / MOTORI**  
MD5A, B, C  
MD6B  
MD7A, B  
MD11C, D  
2001, 2002, 2003AG, B, BG



Ref.	R.O. OEM	IMPULSOR IMPELLER GIRANTE
REC22040		REC21213660

**MOTORES / ENGINES / MOTORI**  
2003T, TB



Ref.	R.O. OEM	IMPULSOR IMPELLER GIRANTE
REC22167		

**MOTORES / ENGINES / MOTORI**  
MD2010C, D  
MD2020C, D  
MD2030C, D  
MD2040C, D

**NEW**



**TAPA 6 TORNILLOS  
6 BOLT COVER  
COPERCHIO 6 VITI**

Ref.	R.O. OEM	IMPULSOR IMPELLER GIRANTE
REC22016		REC3841697 Ø 65 mm

**MOTORES / ENGINES / MOTORI**  
D30, 31, 32, 40, 41, 42, 43, 44



**TAPA 5 TORNILLOS  
5 BOLT COVER  
COPERCHIO 5 VITI**

Ref.	R.O. OEM	IMPULSOR IMPELLER GIRANTE
REC22089		REC21730344 Ø 95 mm

**MOTORES / ENGINES / MOTORI**  
AQAD40A, B  
TAMD40A, B



**CENTRADORES BOMBA ASPIRACIÓN  
WATER PUMPS CROSS PIECES  
CENTRATORI  
POMPA ASPIRAZIONE**

Ref.	R.O. OEM
REC831009	831009 806256

**MOTORES / ENGINES / MOTORI**  
AQ120, 120B, 125, 130, 131, 140A, 145, 151,  
165, 170, 171, 230A, 250A, 251A  
MD3B  
MD17C, D  
MD21A, B



Ref.	R.O. OEM
REC858467	858467

**MOTORES / ENGINES / MOTORI**  
MD31, 41  
KAD32, 42, 43, 44, 300  
KAMD42



**TAPA 6 TORNILLOS  
6 BOLT COVER  
COPERCHIO 6 VITI**

Ref.	R.O. OEM
REC829433	829433

**MOTORES / ENGINES / MOTORI**  
TMD, TAMD, AQAD, MD30A  
TMD, AQD, MD40A



**IMPULSORES  
IMPELLERS  
GIRANTI**



Ref.	R.O. OEM
REC3586494	3586494
JOH09-806B	875807
CEF500100GX	876689

**MOTORES / ENGINES / MOTORI**  
MB10A



Ref.	R.O. OEM
REC3593659	35993659
JOH09-1026B	
CEF500116GX	

**MOTORES / ENGINES / MOTORI**  
AQ95, 100, 110  
AQ115, A, B  
AQ120  
AQ130A, B, C, D  
BB115A, B, C



Ref.	R.O. OEM
REC875575	875575
JOH09-801B	
CEF500170CG	

**MOTORES / ENGINES / MOTORI**  
AQD21A, B  
MD21A, B  
230A, B  
250A, B  
251A  
AQ115A, B  
AQ120B  
AQ125A, B  
AQ130A, B, C, D

AQ131A, B, C, D  
AQ140A  
AQ145A, B  
AQ151A, B, C  
AQ165A  
AQ170A, B, C  
AQ171A, C  
AQD21A  
BB115A, B, C



BB140A  
BB145A  
BB165A  
BB170A, B, C  
MB20A, B, C, D

Ref.	R.O. OEM
REC13554-0001 JOH09-812B CEF500124	13554-0001

Para bomba / For pump / Per pompa: REC3860703

**PARA BOMBA CON POLEA  
FOR PUMP WITH BELT DRIVE  
PER POMPA CON PULEGGIA**

Ref.	R.O. OEM
REC3854286 SHE0959K CEF500103T	3854286

**MOTORES / ENGINES / MOTORI**

3.0GL, GS 5.8FL, Fi, FSi  
4.3GL, GS, GLM MDA, 7.4GL (MD)  
GLP MDA, GSP MDA 8.2GLP MDA, GLP MDM  
5.0FL, Fi AQ200B, C  
5.7GL, Gi, GIP MDA, GIP AQ225B, C  
MDACE, GLP MDA AQ255A

Ref.	R.O. OEM
REC10615K SHE10615K CEF500120T	835874

**MOTORES / ENGINES / MOTORI**

AQ190A  
AQ240A  
64 mm H=41mm

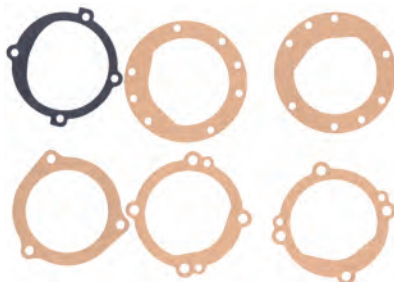

Ref.	R.O. OEM
REC21213664 CEF500178G	21213664

**MOTORES / ENGINES / MOTORI**

3.0GLP-J  
4.3GL-J, GL-JF, GXi-B, GXi-BF,  
GXi-C, GXi-CF, GXi-D, GXi-DF,  
GXi-E, GXi-EF, GXi-J, GXi-JF,  
OSi-B, OSi-BF, OSi-C, OSi-CF,  
OSi-D, OSi-DF, OSi-E, OSi-EF  
5.0GXi-J, GXi-JF  
5.7 Gi-300-J, Gi-300-JF, GXi-J,  
GXi-JF  
8.1Gi-J, Gi-JF, GXi-J, GXi-JF  
8.2GSIPWTR  
AQ60F, 90, 95, 95A, 100, 110, 120  
AQ115A, B

AQ130A, B, C, D  
BB100  
BB115A, B, C  
BB30  
DPX415XWTR  
MB18, F  
MB20A, B, C  
Nuevos modelos / New models / Modeli nuovi

**TAPA 6 TORNILLOS  
6 BOLT COVER  
6 VITE IN COPERCHIO**

Ref.	R.O. OEM
REC22120-0001 CEF500104	876120

**MOTORES / ENGINES / MOTORI**

431A (Earlier produc-  
tion) AQ205A, D  
570A AQ225E, F  
571A AQ255B  
572A AQ260A, B  
AQ200D (w = 50 mm) AQ271A, B, C, D  
AQ280A



AQ290A  
AQ311A, B  
BB225A, B, C  
BB231A  
BB260A, B, C

**TAPA 4 TORNILLOS  
4 BOLT COVER  
COPERCHIO 4 VITI**

Ref.	R.O. OEM
REC21213660 JOH09-1027B CEF500107	21213660

**MOTORES / ENGINES / MOTORI**

430A, B 3.0GL, GS (HU, NC, LK, BY, WT, EF)  
431A, B 4.3GIPBYCCE, GIPLKDCE, GIPNCBCE, GIPNCMCE,  
432A GLPBYC, GLPHUB, GLPLKD, GLPNCA, GLPNCB,  
434A GLPNCS, GSPBYC, GSPLKD, GSPNCB, GSPNCM,  
500A, B GL, GS (MD, HU, NC, LK, BY), Gi  
501A, B 5.0GL, Gi (BY), FL, Fi (HU, NC), FLPNCA, FLPNCS,  
570A GIPBYCCE, GLPBYC  
571A 5.7GL, Gi, GS, GSi, GIPLKECE, GLIPLKDCE, GLPLKA,  
572A GLPLKD, GLPLKE, GSICPLKD, GSIPLKE, GSPBYC,  
AQ175A GSPLKD, GSIPLKE  
AQ200D, F 5.8FL, Fi, FSi (HU, NC), FLPNCA  
AQ205A 7.4Gi, GSi, GL (HU, NC, LK), GIPBYCCE, GIPHUSCE,  
AQ211A GIPLKDCE, GIPLKECE, GIPNCACE, GIPNCBCE,  
AQ231A, B GIPNCMCE, GIPNCSCCE, GLPHUS, GLPLKD, GLPNCA,  
AQ255B GLPNCS, GSIPBYCCE, GSIPLKD, GSIXHUS  
AQ260A, B 8.2GSi (HU, NC, LK, BY), GL (HU), GSIPBYCCE,  
AQ271A, B, C, D GSIPLKD, GSIXNCB  
AQ280A  
AQ290A  
AQ311A, B  
BB225A, B, C  
BB231A,  
BB260A, B, C  
BB261A



**IMPULSORES  
IMPELLERS  
GIRANTI**



Ref.	R.O. OEM
REC21730344 CEF500105T JOH09-1029B	2170344

**MOTORES / ENGINES / MOTORI**

TAMD40 TAMD61A  
AD40 TAMD62A  
D11B2 D11A, B, C (IPS)  
TAMD71B

Ref.	R.O. OEM
REC875575 JOH09-801B CEF500170CG	875575

**MOTORES / ENGINES / MOTORI**

AQD21A, B  
MD21A, B

Ref.	R.O. OEM
CEF500380	3555413

**MOTORES / ENGINES / MOTORI**

MB2, 505



Ref.	R.O. OEM
REC3593659 CEF500116GX JOH09-1026B	3593656 22222936

**MOTORES / ENGINES / MOTORI**  
 D1-13 A, B, F MD2030A, B, C, D  
 D1-20 A, B, F MD2040A, B, C, D  
 D1-30 A, B, F MD3B  
 D2-40 A, B, F MD2020 (101309052+)  
 MD17D MD2010 (5101203008+)



Ref.	R.O. OEM
REC17937-0001 JAB17937-0001-P CEF500114T	3588475

**MOTORES / ENGINES / MOTORI**  
 D4-180i-B, I-C AQ21A  
 D4-210A-A, A-B, i-A, i-B MD21A  
 D4-225A-B, A-C, i-B, I-C AQD21B  
 D4-260A-A, A-B, A-C, MD21B (xxxx103387+)  
 D-B, D-C, i-A, i-B, I-C  
 D4-300A-A, A-C, D-A,  
 D-C, I-A, I-C



Ref.	R.O. OEM
REC3593573 JAB17018-0001 CEF500177GT	3593573 21730348

**MOTORES / ENGINES / MOTORI**  
 D6-280A-A, A-B, i-A, i-B  
 D6-310A-A, A-B, D-A, D-B, i-A, i-B  
 D6-330A-B, A-C, D-B, D-C, I-B, I-C  
 D6-350A-A, A-B  
 D6-370A-B, A-C, D-A, D-B, D-C, i-A, i-B, I-C  
 D6-435D-A, D-C, i-A, I-C  
 D11A-A  
 D9A2A, B, D, F



Ref.	R.O. OEM
REC21213664 CEF500178G	21213664

**MOTORES / ENGINES / MOTORI**  
 D3-110I-A, I-B, I-C  
 D3-130A-A, A-B, A-C, I-A, I-B, I-C  
 D3-160A-A, A-B, A-C, I-A, I-B, I-C  
 D3-190A-B, A-C, I-B, I-C



Ref.	R.O. OEM
JAB17938-0001-P CEF500163G	3830459

**MOTORES / ENGINES / MOTORI**  
 D12C-A, D-A, D-B, D-C, D-D, D-F MP  
 D13B-E, B-N MH  
 D13C1-A, C2-A, C3-A, C4-A MP  
 D12D-A, B, C, E, G MH  
 D12  
 D16C-A, B, C MH, MG



Ref.	R.O. OEM
REC21213660 CEF500207 JOH09-1027B	21213660

**MOTORES / ENGINES / MOTORI**  
 D2-55 A, B, C, D, E  
 D2-75 A, B, C, F  
 MD22A, L-A  
 TMD22A  
 Impulsor con  
 casquillo estriado  
 Grooved socket  
 impeller  
 Girante con mozzo  
 scanalato



Ref.	R.O. OEM
REC3586496 CEF500121GX JOH09-808B	21951342

**MOTORES / ENGINES / MOTORI**  
 2001, B MD11D MD7A, B  
 2002, B MD5A, B, C  
 2003, B MD6B



Ref.	R.O. OEM
REC3586494 CEF500100GX JOH09-806B	3586494

**MOTORES / ENGINES / MOTORI**  
 2003T, TB MD2 (4211+)  
 2010 (-5101203008) MD2010A, B, C, D  
 2020 (-5101309052) MD2020A, B, C, D  
 AQD2B MD22A, L-A, L-B, P-B  
 MD1, 1B, 2, 2B, 6 TAMD22P-B  
 MD1 (14016+) TMD22A, B



AQD21A, B  
 MD21A  
 MD21B (-103386)

Ref.	R.O. OEM
REC3887761 JOH09-821B CEF500162G	21951358 3887761

**MOTORES / ENGINES / MOTORI**  
 TAMD63L-A, P-A D6330A-F, D-F  
 D6-280A-E D6-370A-F, D-F, I-F, A-E, D-E  
 D6-310A-E, D-E D6-400A-F, DF, A-E  
 D6-300A-F, D-F, A-E, D-E D6-435D-F, I-SC-F, I-WJ-F



Ref.	R.O. OEM
REC875697 JOH09-814B CEF500145T	875697 21951364 875814

**MOTORES / ENGINES / MOTORI**  
 TAMD162A, B, C TAMD120B  
 TAMD163A, P-A TAMD121C, D  
 TAMD102A TAMD122A, C, D, P-A, P-B  
 TAMD103A-A



**TAPA 5 TORNILLOS  
5 BOLT COVER  
COPERCHIO 5 VITI**

Ref.	R.O. OEM	
REC21730344 JOH09-819B CEF500135	21951362 8777066	Ø 95 mm

**MOTORES / ENGINES / MOTORI**  
 AQAD40A, B TAMD62A  
 MD100A, B TAMD71A, B  
 MD120A TAMD72A, P-A  
 TAMD120A TMD100A, C  
 TAMD40B TMD102A  
 TAMD61A TMD120A, B



TMD121C  
 TMD122A  
 TAMD73P-A, WJ-A  
 TAMD74A-A, A-B, C-A,  
 L-A, L-B7, P-A, P-B  
 TAMD75P-A

**TAPA 6 TORNILLOS  
6 BOLT COVER  
COPERCHIO 6 VITI**

Ref.	R.O. OEM	
REC3841697 JOH09-1028B CEF500106GT	3841697 21951356	Ø 65 mm

**MOTORES / ENGINES / MOTORI**  
 AD31A, B, D, L-A, P-A, X KAMD300-A  
 AD41A, B, D, L-A, P-A KAMD42A, B, P-A  
 AQAD30A, 31A, 41A KAMD43P  
 AQD32A, 40A, 41A KAMD44P-A, P-B, P-C  
 AQD70B, C, D MD30A, 31A, 32A,  
 D4 70B, 70C  
 D41A, B, D TAMD30A  
 KAD300-A TAMD31A, B, D, L-A,  
 KAD32P M-A, P-A, S  
 KAD42A, B, P-A TAMD41A, B, D, H-A,  
 KAD43P, P-A M-A, P-A  
 KAD44P, P-B, P-C TAMD42WJ-A



TAMD60A, B  
 TAMD70B, C, D, E  
 TMD30A  
 TMD31A, B, D, L-A  
 TMD40A, B, C  
 TMD41A, B, D, L-A  
 THAMD70B-C

GUÍA IMPULSORES (MÁS COMUNES)  
 IMPELLER APPLICATION (MORE COMMON)  
 GUIDA GIRANTI (PIÙ COMUNI)



MOTORES ENGINES MOTORI	REC	CEF	JABSCO	JOHNSON	SHERWOOD
3.0GLP-C	REC21213660	CEF500107T		JOH09-1027B	
3.0GLP-D, E, J      3.0GXJ-J      3.0GXIC-J	REC21213664	CEF500178G			
4.3GL-J/JF, GXI-J/JF, G/GF, OSI-J/JF, G/GF	REC21213664	CEF500178G			
5.0GL-J/JF, GXI-J/JF, G/G-F, OSI-J/JF, G/G-F	REC21213664	CEF500178G			
5.7Gi300-J/JF/F/FF, OSI-J/JF, GXI-J/JF/G/GF, OSXi-J/JF/E/EF	REC21213664	CEF500178G			
7.4GL (MD)	REC3854286	CEF500103T			SHE09959K
7.4GL (HU,NC,LK), Gi, Gsi, DPX385	REC21213660	CEF500107T		JOH09-1027B	
8.1Gi-J/JF,H/HF, Gxi-J/JF,G/GF, Osi-J/JF, D/DF	REC21213664	CEF500178G			
8.2GL	REC3854286	CEF500103T			SHE09959K
8.2GSi, DPX415 (HU-BY-WT)	REC21213660	CEF500107T		JOH09-1027B	
500A, B      501A, B	REC21213660	CEF500107T		JOH09-1027B	
570A (IMPELLER Large=31)      571A      572A      AQ225B	REC21213660	CEF500107T		JOH09-1027B	
570A (IMPELLER Large=50)      571A      572A      740A,B	REC18777-0001	CEF500104	JAB18777-0001-P		
AQ95, 100, 110      AQ115, A, B      BB115A, B, C      AQ120	REC3593659	CEF500116GX		JOH09-1026B	
AQ130A, B, C, D      AQ120B      AQ125A,B      AQ131A, B, C, D      AQ140, A      BB140A      BB145A      AQ145A,B      AQ151A, B, C      AQ165      AQ170A, B, C      AQ171      230A, B	REC875575	CEF500170CG		JOH09-801B	
250B					
AQ225A, B,C	REC3854286	CEF500103T			SHE09959K
AQ225B, D, E, F      BB225A, B, C      BB231A      AQ260A, B      BB260A, B, C      BB261A      AQ271A, B, C, D      AQ280A	REC18777-0001	CEF500104	JAB18777-0001-P		
AQ290A (IMPELLER Large=50)      AQ231A, B      AQ260A      BB225A, B, C      BB260A, B, C      BB261A      AQ271A, B, C, D      AQ280A      AQ290A	REC21213660	CEF500107T		JOH09-1027B	
AQ311A, B (IMPELLER Large=31)					

GUÍA IMPULSORES (MÁS COMUNES)  
 IMPELLER APPLICATION (MORE COMMON)  
 GUIDA GIRANTI (PIÙ COMUNI)



MOTORES ENGINES MOTORI	REC	CEF	JABSCO	JOHNSON
MD1A, B      MD2A, B      MD5A, B, C      MD6A, B	REC3586496	CEF500121GX		JOH09-808B
MD7A, B      MD11C, D (Lid 4 screws)      MD5A, B, C      MD6A, B	REC3586494	CEF500100GX		JOH09-806B
MD1A, B      MD2A, B      MD5A, B, C      MD6A, B	REC3586494	CEF500100GX		JOH09-806B
MD11C, D (Lid 6 screws)      MD17C, D      2001      2002	REC3586496	CEF500121GX		JOH09-808B
MD3B      MD17C, D      2001      2002	REC3586496	CEF500121GX		JOH09-808B
2003				
MD21A, B      AQAD21A, B	REC875575	CEF500170CG		JOH09-801B
MD22A, B      TMD22A, B      TAMD22A      2003T		CEF500107T		JOH09-1027B
D2-50, -55, -60, -75      TMD22A, B      TAMD22A      2003T	REC3586494	CEF500100GX		JOH09-806B
MD2010 SN -5101309052      TAMD22A, B      TAMD22A      2003T	REC3586494	CEF500100GX		JOH09-806B
MD2020 SN -5101309052      TAMD22A, B      TAMD22A      2003T	REC3586494	CEF500100GX		JOH09-806B
MD2010 SN +5101203009      TAMD22A, B      TAMD22A      2003T	REC3593659	CEF500116GX		JOH09-1026B
MD2020 SN +5101309053      TAMD22A, B      TAMD22A      2003T	REC3593659	CEF500116GX		JOH09-1026B
MD2030      TAMD22A, B      TAMD22A      2003T				
MD2040      TAMD22A, B      TAMD22A      2003T				
MD30A, B, D, AQ      TAMD30A, B, D, AQ      TMD30A, B, D, AQ      AQAD30A, 31A      AD31, A, B, D, XC, P, -A      MD31, A      TMD31A, B, D, L-A      TAMD31A, B, D, P, L, M, S-A      KAD32A      MD40A      TMD40A, B, C      TAMD40B      AQD40A      AQAD40A, B      TMD41A, B, D, L-A      TAMD41A, B, D      D41A, B, D, L-A      AD41A, B, D      AQD41A      AQAD41A      TAMD41P, L, M, H-A, H-B      AD41P, L-A      KAD42A, B, P-A      KAMD42A, B, P-A	REC3841697	CEF500106GT		JOH09-1028B
TAMD40      TAMD40A, B, D, L-A      AD41A, B, D      AQD41A      AQAD41A      TAMD41P, L, M, H-A, H-B      AD41P, L-A      KAD42A, B, P-A      KAMD42A, B, P-A	REC21730344	CEF500105T		JOH09-1029B
AD40      KAMD43P-A      KAMD43P-A      KAD44P-A, P-B, P-C      KAMD44P-A, P-B, P-C	REC3841697	CEF500106GT		JOH09-1028B
KAD300A      KAMD300A	REC3593659	CEF500116GX		JOH09-1026B
D1-13, -20, -30, -40	REC21213664	CEF500178G		
D3	REC21213664	CEF500178G		
D4 E-F AQ & IPS	REC3841697	CEF500106GT		JOH09-1028B
D4 A-D AQ & IPS, ALL INBOARD MODELS		CEF500114T	JAB17937-0001-P	
D6 E-F AQ & IPS	REC3887761	CEF500162G		JOH09-821B
D6 A-D AQ & AQ & IPS, ALL INBOARD MODELS	REC3593573	CEF500177GT	JAB17018-0001	

**KITS REPARACIÓN BOMBA ASPIRACIÓN  
RUBBER IMPELLER WATER PUMPS SERVICES KIT  
KITS RIPARAZIONE POMPA ASPIRAZIONE**

Ref.	R.O. OEM	IMPULSOR IMPELLER GIRANTE
REC22073		REC3593659

**MOTORES / ENGINES / MOTORI**

AQ60, 90, 95, 100, 105, 110, 115, 120, 130  
MD18, 20, 3B, 17C, 17D



Ref.	R.O. OEM	IMPULSOR IMPELLER GIRANTE
REC875383	875383	REC875575

**MOTORES / ENGINES / MOTORI**

AQ165A, 170A, 170B, 170C  
BB165A, 170A, 170B, 170C  
MD21A (103387+), 21B  
AQD21A (103387+), 21B

Viene sin leva  
Cam not included  
Camma non inclusa



Ref.	R.O. OEM	IMPULSOR IMPELLER GIRANTE
REC875698	875698 21951420	REC875698

**MOTORES / ENGINES / MOTORI**

AQ60, 90, 95, 100, 105, 110, 115, 120, 130  
MD3B, 17C, 17D  
MB18  
M20A, B, C



Ref.	R.O. OEM	IMPULSOR IMPELLER GIRANTE
REC875574	875574 876081	REC875575

**MOTORES / ENGINES / MOTORI**

AQ120B  
AQ125A, B  
AQ131A, B, C, D  
AQ140A  
AQ145A, B  
AQ151A, B, C

Viene sin leva  
Cam not included  
Camma non inclusa



Ref.	R.O. OEM	NEW
REC23035		

**MOTORES / ENGINES / MOTORI**

MD2010C, D  
MD2020C, D  
MD2030A, B, C, D  
MD2040A, B, C, D  
D1-13A, B, F  
D1-20A, B, F  
D1-30A, B, F  
D2-40A, B, F



Ref.	R.O. OEM	IMPULSOR IMPELLER GIRANTE
REC875584	875584	REC3586496

**MOTORES / ENGINES / MOTORI**

MD5A, B, C  
MD6B  
MD7A, B  
MD11C

Viene sin leva y sin tapa  
Cam & cover not included  
Camma e coperchio non inclusi



Ref.	R.O. OEM	NEW
REC23038		

**MOTORES / ENGINES / MOTORI**

D2-55A, B, C, D, E, F  
D2-75A, B, C, F



Ref.	R.O. OEM	IMPULSOR IMPELLER GIRANTE
REC875756	875756	REC3586496

**MOTORES / ENGINES / MOTORI**

2001, 2003 AG, B, BG  
2002AG, B, BG, D  
MD1A, B  
MD2A, B  
MD5A, B, C  
MD6A, B  
MD7A, B  
MD11C, D  
AQD2B

Viene sin leva y sin tapa. No para turbo.  
Cam & cover not included. Not for turbo.  
Camma e coperchio non inclusi. Non per turbo.



Ref.	R.O. OEM	NEW
REC23040		

**MOTORES / ENGINES / MOTORI**

D12D-A MH, D-B MH,  
D-A MP, D-B MP, D-C MP,  
D-D MP, D-E MP, D-F MP,  
D-G MP, D-H MP, D-C MH,  
C-A MP  
D16C-A MH, C-B MH,  
C-C MH, C-A MG



Ref.	R.O. OEM	IMPULSOR IMPELLER GIRANTE
REC877373	877373 876088 876529 875759	REC3841697 Ø 65 mm

**MOTORES / ENGINES / MOTORI**

31, 32, 40, 41, 42, 43, 44, 300



Ref.	R.O. OEM	IMPULSOR IMPELLER GIRANTE
------	----------	---------------------------------

REC875769 875769 21951410 REC21730344 Ø 95 mm

**MOTORES / ENGINES / MOTORI**  
AD40B  
AQAD40A, B  
TAMD40A, B



Ref.	R.O. OEM	PARA BOMBA FOR PUMP PER POMPA
------	----------	-------------------------------------

REC062MINORKIT REC3584062

**NEW**



Ref.	R.O. OEM	PARA BOMBA FOR PUMP PER POMPA
------	----------	-------------------------------------

REC890MINORKIT REC21380890

**NEW**



Ref.	R.O. OEM	PARA BOMBA FOR PUMP PER POMPA
------	----------	-------------------------------------

REC376MINORKIT REC21419376

**NEW**



Ref.	R.O. OEM	PARA BOMBA FOR PUMP PER POMPA
------	----------	-------------------------------------

REC374MINORKIT REC21419374

**NEW**



Ref.	R.O. OEM	PARA BOMBA FOR PUMP PER POMPA
------	----------	-------------------------------------

REC288MINORKIT REC3838288

PAG 341

**NEW**



Ref.	R.O. OEM	PARA BOMBA FOR PUMP PER POMPA
------	----------	-------------------------------------

REC886MINORKIT REC21380886

PAG 341

**NEW**



Ref.	R.O. OEM	PARA BOMBA FOR PUMP PER POMPA
------	----------	-------------------------------------

REC494MINORKIT REC22063494

PAG 341

**NEW**



Ref.	R.O. OEM	PARA BOMBA FOR PUMP PER POMPA
------	----------	-------------------------------------

REC723MINORKIT REC21219723

PAG 341

**NEW**



Ref.	R.O. OEM	PARA BOMBA FOR PUMP PER POMPA
------	----------	-------------------------------------

REC207MINORKIT REC3838207

PAG 342

**NEW**



Ref.	R.O. OEM	PARA BOMBA FOR PUMP PER POMPA
REC150MINORKIT	REC22905150	

**NEW**

Ref.	R.O. OEM	PARA BOMBA FOR PUMP PER POMPA
REC155MINORKIT	REC22905155	

**NEW**

**RETENES BOMBA AGUA  
WATER PUMPS SEALS  
PARAOLIO POMPA ACQUA**

Ref.	R.O. OEM
REC804695	804695

**MOTORES / ENGINES / MOTORI**  
AQ60, 90, 95, 100, 105, 110, 115, 120A, 130  
MB10A, 18, 20

Ref.	R.O. OEM
REC833996	833996

**MOTORES / ENGINES / MOTORI**  
AQ60, 90, 95, 100, 105, 110, 115, 120A, 130  
MB18, 20

Ref.	R.O. OEM
REC827247	827247

**MOTORES / ENGINES / MOTORI**  
AQ120B, 125, 131, 140, 145, 151, 165, 170, 171, 230A, 250A, 251A  
AQ430A, B  
AQ431A, B  
500A, B  
501A, B  
570A, 571A, 572A  
Para bomba con tapa de 4 tornillos. Todas las bombas V6/V8 modernas instaladas en cigüeñal.  
4 bolt cover. All modern V6 / V8 pumps installed on crankshaft.  
Per pompa con 4 viti nel coperchio. Tutte le moderne pompe V6 / V8 installate sull'albero motore.

**RETENES BOMBA AGUA  
WATER PUMPS SEALS  
PARAOLIO POMPA ACQUA**



Ref.	R.O. OEM
REC804695	804695

**MOTORES / ENGINES / MOTORI**  
MD1B, 2B, 3B, 6A  
MD17C, D

Ref.	R.O. OEM
REC833996	833996

**MOTORES / ENGINES / MOTORI**  
MD3B  
MD5A, B, C, D1, D2  
MD6B  
MD7A, B  
MD11C, D, 2001, 2002, 2003  
MD17C, D  
2010, 2020, 2030, 2040  
Para bombas con rodamiento en eje bomba  
For pumps with bearing in shaft  
Per pompa con cuscinetto nell'asse della pompa

Ref.	R.O. OEM
REC827247	827247

**MOTORES / ENGINES / MOTORI**  
2003T  
MD21A (103387+), B  
MD30, 31, 40, 41  
KAD42A  
KAMD42A, D3, 300  
Para bomba con tapa de 6 tornillos  
6 bolt cover  
Per pompa con 6 viti in coperchio

**RETENES TUBOS  
REFRIGERACIÓN MOTORES  
ENGINE HOSES SEALS  
GOMMINI TUBI DI REFRIGERAZIONE**

Ref.	R.O. OEM	Ø EXT
REC831622	831622	29 mm

**MOTORES / ENGINES / MOTORI**  
AQ120B AQ145A, B  
AQ125A, B AQ151A, B, C  
AQ131A, B, C, D AQ171A, C  
AQ140A  
Aro en forma de U  
U shape ring  
O-ring a forma di U

Ref.	R.O. OEM	Ø EXT
REC831617	831617	29 mm

**MOTORES / ENGINES / MOTORI**  
AQ165A  
AQ170A, B, C,  
MD21 (103387+), B  
Aro en forma de U  
U shape ring  
O-ring a forma di U

Ref.	R.O. OEM	Ø EXT
REC829714	829714	17 mm

**MOTORES / ENGINES / MOTORI**  
AQ90, 95, 100, 105, 110, 115, 120, 130  
MB10A  
MD5A, B, C  
MD7A, B  
MD11D

Ref.	R.O. OEM	Ø EXT
------	----------	-------

REC418411 418411 20 mm

**MOTORES / ENGINES / MOTORI**  
 AQ90, 95, 100, 105, 110, 115, 120, 130  
 MB18, 20  
 MD11C, D  
 MD17C, D  
 2001, 2002, 2003



Ref.	R.O. OEM	Ø EXT
------	----------	-------

REC418412 418412 27 mm

**MOTORES / ENGINES / MOTORI**  
 AQ120B AQ165A  
 AQ125A, B AQ170A, B, C  
 AQ131A, B, C, D AQ171A, C  
 AQ140A 230A, 250A, 251A  
 AQ145A, B MD21A, B  
 AQ151A, B, C, D



Ref.	R.O. OEM	Ø EXT
------	----------	-------

RM831960 831960 21 mm

**MOTORES / ENGINES / MOTORI**  
 2001, 2002, 2003



Ref.	R.O. OEM	Ø EXT
------	----------	-------

REC418445 418445 23 mm

**MOTORES / ENGINES / MOTORI**  
 AQ90, 95, 100, 105, 110, 115, 120, 130  
 MD11C, D  
 MD17C, D  
 2001, 2002, 2003



Ref.	R.O. OEM	Ø EXT
------	----------	-------

REC430020 430020 34 mm

**MOTORES / ENGINES / MOTORI**  
 AQ120B AQ145A, B  
 AQ125A, B AQ151A, B, C  
 AQ131A, B, C, D AQ171A, C  
 AQ140A 230A, 250A, 251A



**KITS RETENES TUBOS REFRIGERACIÓN MOTORES**  
**ENGINE HOSES SEALS KIT**  
**KIT GOMMINI TUBI DI REFRIGERAZIONE**

Ref.	R.O. OEM
------	----------

REC22061

**MOTORES / ENGINES / MOTORI**  
 AQ115, 130  
 BB115



Ref.	R.O. OEM
------	----------

REC22051

**MOTORES / ENGINES / MOTORI**  
 AQ120B, 125, 140, 145  
 BB140A, 145A



Ref.	R.O. OEM
------	----------

REC22037

**MOTORES / ENGINES / MOTORI**  
 AQ131, 151, 171, 230, 250, 251



Ref.	R.O. OEM
------	----------

REC22012

**MOTORES / ENGINES / MOTORI**  
 AQ165, 170  
 BB165, 170



**KITS RETENES TUBOS REFRIGERACIÓN MOTORES**  
**ENGINE HOSES SEALS KIT**  
**KIT GOMMINI TUBI DI REFRIGERAZIONE**

Ref.	R.O. OEM
------	----------

REC22011 876224

**MOTORES / ENGINES / MOTORI**  
 2001, 2002, 2003, AG, B, BG



Ref.	R.O. OEM
------	----------

REC22017

**MOTORES / ENGINES / MOTORI**  
 2002, 2003, AG, B, BG  
 Con circuito agua dulce.  
 Fresh water cooling system  
 Circuito acqua dolce



Ref.	R.O. OEM
------	----------

REC22008

**MOTORES / ENGINES / MOTORI**  
 2003T, TB  
 Con circuito agua dulce.  
 Fresh water cooling system  
 Circuito acqua dolce



Ref.	R.O. OEM
------	----------

REC22019

**MOTORES / ENGINES / MOTORI**  
 MD5A, B, C



Ref.	R.O. OEM
------	----------

REC22024

**MOTORES / ENGINES / MOTORI**  
 MD6A, B  
 MD7A, B





Ref.	R.O. OEM
REC22021	

**MOTORES / ENGINES / MOTORI**  
MD11C, D



Ref.	R.O. OEM
REC22025	

**MOTORES / ENGINES / MOTORI**  
MD17C, D



Ref.	R.O. OEM
REC22114	

**MOTORES / ENGINES / MOTORI**  
MD30A  
TMD30A



Ref.	R.O. OEM
REC22115	

**MOTORES / ENGINES / MOTORI**  
AQAD30A  
TAMD30A  
AD30A



Ref.	R.O. OEM
REC22116	

**MOTORES / ENGINES / MOTORI**  
MD40A  
TMD40A, B, C  
TAMD40A, B  
AQD40A  
AQAD40A  
AD40B



Ref.	R.O. OEM
REC22113	

**MOTORES / ENGINES / MOTOR**  
D31, 32, 41, 42, 43, 44



**TAPONES DRENAJE  
DRAIN TAPS  
RUBINETTI**

Ref.	R.O. OEM	Ø
REC82744	82744	1/8"

**MOTORES / ENGINES / MOTORI**  
AQ60, 90, 95, 100, 105, 110, 115, 120,  
130, 140, 145, 151, 165, 170, 171, 230A,  
250A, 251A  
MB10A, 18, 20  
MD19, 21, 27, 29, 32



Ref.	R.O. OEM	Ø
REC966871	966871	1/8"

**MOTORES / ENGINES / MOTORI**  
AQ60, 90, 95, 100, 105, 110, 115, 120,  
130, 140, 145, 151, 165, 170, 171,  
230A, 250A, 251A  
MB10A, 18, 20  
MD19, 21, 27, 29, 32



Ref.	R.O. OEM	Ø
REC82745	82745	1/4"

**MOTORES / ENGINES / MOTORI**  
AQ90, 95, 100, 105, 110, 115, 120, 130, 140,  
145, 151, 165, 170, 171, 230A, 250A, 251A  
MB18, 20  
AQD40  
AQAD40  
TMD40



Ref.	R.O. OEM	Ø
REC807036	807036	10 x 1

**MOTORES / ENGINES / MOTORI**  
MD1A, B  
MD2A, B  
MD3B  
MD5A, B  
MD6A  
MD6B (Versión antigua / Old version / Versione  
vecchia)



Ref.	R.O. OEM	Ø
REC829592	829592	

**MOTORES / ENGINES / MOTORI**  
MD5C  
MD11C, D  
MD17C, D



Ref.	R.O. OEM	Ø
REC997641	949918	1/4"

**MOTORES / ENGINES / MOTORI**  
230A, 250A, 251A, 430, 431  
500B, 501B, 570, 572  
MD30, 31, 40, 41



Ref.	R.O. OEM	Ø
REC947893	947893	1/4"

**MOTORES / ENGINES / MOTORI**  
MD31A, B  
MD40, 41B  
2001, 2002, 2003



Ref.	R.O. OEM	Ø
REC947894	947894	1/4"

**MOTORES / ENGINES / MOTORI**  
AQ151, 171  
230A, 250A, 251A



# TERMOSTATO THERMOSTAT TERMOSTATO

## KITS TERMOSTATO THERMOSTAT KITS KIT TERMOSTATI



Ref.	R.O. OEM	
REC876080	876080	60 °C
	876797	
	875781	
	875790	
	824912 82812	



**MOTORES / ENGINES / MOTORI**  
AQ60, 90, 95, 110, 105, 115, 120A, 130  
MB18  
MB20A, B, C

Ref.	R.O. OEM	
REC875791	875791	55 °C
	831040	



**MOTORES / ENGINES / MOTORI**  
AQ165A  
AQ170A, B, C  
BB165, 170

Ref.	R.O. OEM	
REC875580	875580	82 °C



**MOTORES / ENGINES / MOTORI**  
AQ120B  
AQ125A, B  
AQ131A, B, C, D  
AQ140A  
AQ145A, B  
AQ151A, B, C  
AQ171A, C  
230A  
250A  
251A, B  
BB140

Ref.	R.O. OEM	
REC875796	875796	60 °C



**MOTORES / ENGINES / MOTORI**  
MB10A

Ref.	R.O. OEM	
REC876305	876305	62 °C
	875794	
	424299	
	835177	



**MOTORES / ENGINES / MOTORI**  
Todos los V6 y V8 antiguos  
V6 & V8 all old style  
Tutti i V6 e V8 vecchi



Ref.	R.O. OEM	
REC3853799	3853799	71 °C



**MOTORES / ENGINES / MOTORI**  
3.0GS, GSM-A, GLM-A, GLP-A,  
GSM-B, GSM-C, GSP-A, GSP-B, GSP-C

Ref.	R.O. OEM	
REC3853983	3853983	60 °C

**MOTORES / ENGINES / MOTORI**  
7.4 GL, Gi, GSi,  
8.2 GL, GSi



Ref.	R.O. OEM	
REC3587597	3587597	66 °C

**MOTORES / ENGINES / MOTORI**  
4.3GL-B, C, E  
4.3GXi-F, Si-F  
5.0GL-F, C, D  
5.0GXi-F, OSi-F  
5.7GL-C, D  
5.7Gi-F, OSi-E, GXi-G,  
OSXi-E



Ref.	R.O. OEM	
REC3856961	3856961	70 °C

**MOTORES / ENGINES / MOTORI**  
4.3 GL, GS, Gi, GXi-B, GXi-BF  
5.0 FL, Fi, Gi, GL  
5.7 GL, Gi, GS, GSi, GSX  
5.8 FL, Fi, FSi  
8.1 Gi, GSi, GXi, OSi



Ref.	R.O. OEM	
REC3831426	3831426	70 °C
	875788	
	824200	

**MOTORES / ENGINES / MOTORI**  
V8, D40  
5.0GXi-EF, 00Si-EF  
8.1GXi A, B, C  
8.1GXi AF, BF, CF  
8.1GXil-A, B, C  
8.1GiA, B, C, D  
8.1Gi-BF, CF, DF  
8.1GiL-A, B, C, D



## CUERPO TERMOSTATO THERMOSTAT HOUSING CORPO TERMOSTATO

Ref.	R.O. OEM	
REC3850360	3850360	

**MOTORES / ENGINES / MOTORI**  
V6 & V8 (1993-11)



**KITS TERMOSTATO  
THERMOSTAT KITS  
KIT TERMOSTATI**



Ref.	R.O. OEM	
REC876080	876080 876097	60 °C

**MOTORES / ENGINES / MOTORI**  
MD2A, B  
MD3B  
MD11C, D  
MD17C, D



Ref.	R.O. OEM	
REC875783	875783	60 °C

**MOTORES / ENGINES / MOTORI**  
MD5A, B, C



Ref.	R.O. OEM	
REC875796	875796	60 °C

**MOTORES / ENGINES / MOTORI**  
MD6A, B  
MD7A, B



Ref.	R.O. OEM		CIRCUITO CERRADO FRESH WATER CIRCUIT CIRCUITO APERTO
REC877355	877355	62 °C	X
RM875795	875795	74 °C	✓

**MOTORES / ENGINES / MOTORI**  
2001AG, B, BG  
2002AG, B, BG, D  
2003AG, B, BG, D, T, TB



Ref.	R.O. OEM	
RM861911	861911	75°C

**MOTORES / ENGINES / MOTORI**  
2010A, B, C, D  
2020A, B, C, D



Ref.	R.O. OEM	
RM3580365	3580365	82°C

**MOTORES / ENGINES / MOTORI**  
D2-55A, B  
MD2030A, B, C, D  
MD2040A, B, C, D



Ref.	R.O. OEM	
REC877349	877349	74 °C

**MOTORES / ENGINES / MOTORI**  
Para motores con circuito cerrado de refrigeración  
Raw water cooling system engines  
Per motori con circuito di raffreddamento chiuso  
MD11C, D  
MD17C, D



Ref.	R.O. OEM	
REC875785	875785	71 °C

**MOTORES / ENGINES / MOTORI**  
MD19, 27, 29A, 32A  
MD21A, B  
AQD19, 27, 29A, 32A  
AQD21A, B



Ref.	R.O. OEM	
RM6210419	6210419	

**MOTORES / ENGINES / MOTORI**  
MD22A, L-A, L-B, P-B  
TMD22A, B, P-C  
TAMD22P-B



Ref.	R.O. OEM	
REC3831426	3831426	70°C

**MOTORES / ENGINES / MOTORI**  
MD31A (versión antigua / old style / versione vecchia)  
MD40A  
MD41A (versión antigua / old style / versione vecchia)  
(Se necesita1 pieza / 1 piece needed / Ne serve 1 pz)



Ref.	R.O. OEM	
REC3831424	3831424	81°C

**MOTORES / ENGINES / MOTORI**  
MD31 (Versión moderna / New style / versione moderna)  
MD41 (Versión moderna / New style / versione moderna)  
KAD32, 42, 43, 44, 300



Ref.	R.O. OEM	
REC3831425	3831425	76°C

**MOTORES / ENGINES / MOTORI**  
MD30A (Se necesitan 2 piezas / 2 pcs. needed / Ne servono 2 pz)  
MD40A (Se necesita1 pieza / 1 piece needed / Ne serve 1 pz)



Ref.	R.O. OEM	
REC3839110	3839110	75°C

**MOTORES / ENGINES / MOTORI**  
TAMD61, 62, 63, 71, 72, 73, 74-P  
162C, 163A-A, 163P-A



Ref.	R.O. OEM	
RM3842015	3842015	90°C

**MOTORES / ENGINES / MOTORI**  
D1-13A, B, F  
D1-20A, B, F  
D1-30A, B, F  
D2-40A, B, F



Ref.	R.O. OEM	
RM888624	888624	83°C

**MOTORES / ENGINES / MOTORI**  
D1-20A, B, F  
D2-50F  
D2-55C, D, F  
D2-75A, B, C, F  
D2-60F



Ref.	R.O. OEM	
REC3840816	3840816	79°C

**MOTORES / ENGINES / MOTORI**  
D3 110 -> D3 220HP



Ref.	R.O. OEM	
REC8149182	8149182	82°C

**MOTORES / ENGINES / MOTORI**  
D4, 6,  
TAMD63L-A, P-A  
TAMD122A, P-A, P-C  
TMD122A, P-B



Ref.	R.O. OEM	
RM3588437	3588437	82°C

**MOTORES / ENGINES / MOTORI**  
D4, 6  
En intercooler / In intercooler / In intercooler

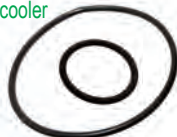

Ref.	R.O. OEM	
REC20450736	20450736	82°C

**MOTORES / ENGINES / MOTORI**  
D5A-A TA, A-B TA  
D7A-B TA, C-B TA, C-A TA  
TD420VE  
TAD420VE, 620VE, 650VE, 660VE, 750VE,  
760VE



Ref.	R.O. OEM	
RM21412646	21412646	86°C

**MOTORES / ENGINES / MOTORI**  
D9A2



Ref.	R.O. OEM	
RM21412647	21412647	76°C

**MOTORES / ENGINES / MOTORI**  
D11A, B



Ref.	R.O. OEM	
REC21412639	21412639	82°C

**MOTORES / ENGINES / MOTORI**  
D9A2, A-MG  
D12C-A, D-A, D-B, D-G, D-H (MP)  
D13B-A, B-B, B-C, B-D, B-E, B-G, G-H (MP)



Ref.	R.O. OEM	
REC876080		60°C

**MOTORES / ENGINES / MOTORI**  
AQD2B  
MD2B, 3B  
MD11C, D  
MD17C, D



## JUNTAS TERMOSTATO ENGINE THERMOSTAT GASKET GUARNIZIONE TERMOSTATI

Ref.	R.O. OEM	
REC27-33918	835417 3852111	



Ref.	R.O. OEM	
REC835581	835581	



Ref.	R.O. OEM	
REC856004	856004	



Ref.	R.O. OEM	
REC1542187	1542187	

**MOTORES / ENGINES / MOTORI**  
30, 31, 32, 40, 41, 42, 43, 44, 300



Ref.	R.O. OEM	
REC27-8146801	3852096	

**MOTORES / ENGINES / MOTORI**  
3.0L



Ref.	R.O. OEM	
REC0307239	3852071	



Ref.	R.O. OEM	
REC3583780	3583780	

**MOTORES / ENGINES / MOTORI**  
MD2040A, B, C, D  
D2-55, B, C, D, E, F



Ref.	R.O. OEM	
REC3580514	3580514	

**MOTORES / ENGINES / MOTORI**  
MD2040A, B, C, D  
D2-50F  
D2-55, B, C, D, E, F



# INTERCAMBIADOR DE CALOR HEAT EXCHANGER SCAMBIATORI DI CALORE

## KIT RETENES Y JUNTAS SEALS & GASKET KIT KIT TENUTE E GUARNIZIONE

Ref. R.O. OEM  
REC23011

MOTORES / ENGINES / MOTORI  
D2-55A, B

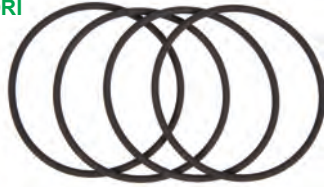

Ref. R.O. OEM  
REC23012

MOTORES / ENGINES / MOTORI  
D2-55C, D, F  
D2-75A, B, C, F

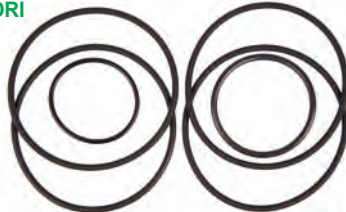

Ref. R.O. OEM  
REC23013

MOTORES / ENGINES / MOTORI  
D3-110I-A, I-B, I-C  
D3-130A-A, A-B, A-C, I-A, I-B, I-C  
D3-160A-A, A-B, A-C, I-A, I-B, I-C  
D3-190A-B, A-C, I-B, I-C

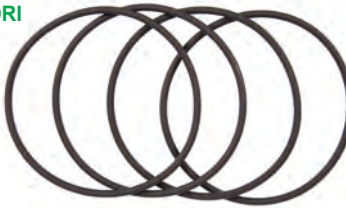

Ref. R.O. OEM  
REC23014

MOTORES / ENGINES / MOTORI  
D4-180I-F, I-B, I-C, I-D, I-E  
D4-210A-A, I-A, I-B  
D4-225A-F, I-F, A-B, I-B, A-C, A-D, I-C, I-D, A-E, I-E  
D4-260A-F, D-F, I-F, A-A, A-B, A-C, A-D, D-B, D-C, D-D, I-A, I-B, I-C, I-D, D-E, I-E, A-E  
D4-300A-F, D-F, I-F, A-A, A-C, A-D, D-A, D-C, I-A, I-C, I-D, A-E, D-E, D-D, I-E  
D6-280A-A, A-B, A-C, A-D, A-E, I-A, I-B, I-C, I-D, I-E  
D6-310I-A, A-A, A-B, A-C, A-D, D-B, D-C, D-D, I-B, I-C, I-D, A-E, D-E, I-E  
D6-330A-B, A-C, A-D, D-B, D-C, D-D, I-B, I-C, I-D, A-E, D-E, I-E  
D6-350A-A, A-B  
D6-370A-B, A-C, A-D, D-B, D-C, D-D, I-A, I-B, I-C, I-D, A-E, D-E, I-E  
D6-400A-E,  
D6-435D-A, D-D, D-C, D-E, I-A, I-C, I-D, I-E

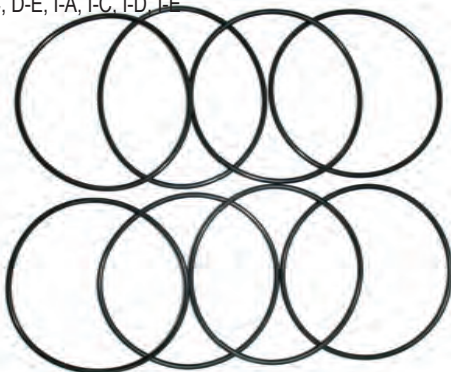

Ref. R.O. OEM  
REC23015

MOTORES / ENGINES / MOTORI  
D1-13A, B, F  
D1-20A, B, F  
D1-30A, B, F

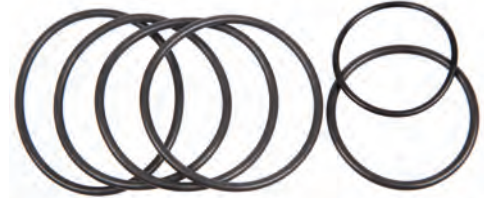

Ref. R.O. OEM  
REC22155

MOTORES / ENGINES / MOTORI  
D22  
MD22A, L-A



Ref. R.O. OEM  
REC22077

MOTORES / ENGINES / MOTORI  
D22  
MD22L-B, P-B



Ref. R.O. OEM  
REC22156

MOTORES / ENGINES / MOTORI  
D22  
TMD22A



Ref. R.O.  
OEM

REC22148

MOTORES / ENGINES / MOTORI

D22  
TMD22B  
TAMD22P-B

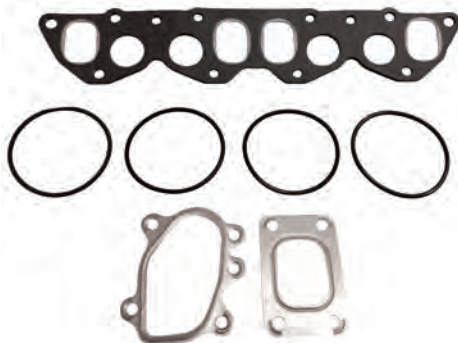

Ref. R.O.  
OEM

REC22032

MOTORES / ENGINES / MOTORI

Para circuito de agua dulce  
Fresh water cooling system  
Per circuito acqua dolce  
2002, 2003 AG, B, BG

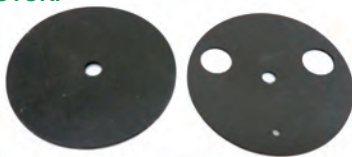

Ref. R.O.  
OEM

REC22033

MOTORES / ENGINES / MOTORI

Para circuito de agua dulce  
Fresh water cooling system  
Per circuito acqua dolce  
2003T, TB

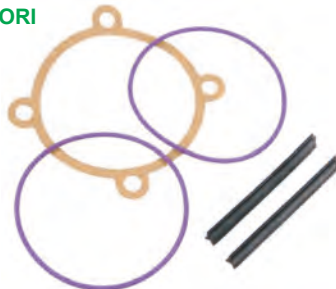

Ref. R.O.  
OEM

REC22122

MOTORES / ENGINES / MOTORI

MD21A

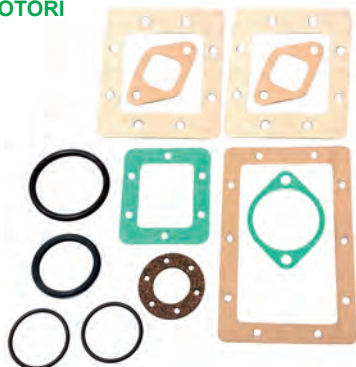

Ref. R.O.  
OEM

REC22123

MOTORES / ENGINES / MOTORI

AQD21A  
MD21B



Ref. R.O.  
OEM

REC22124

MOTORES / ENGINES / MOTORI

AQD29, A  
AQD32A  
MD29, A  
MD32A

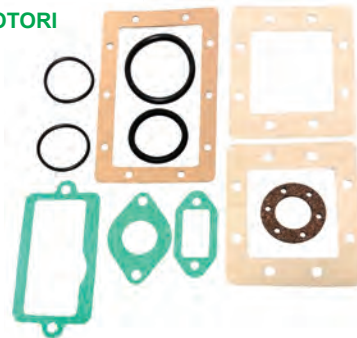

Ref. R.O.  
OEM

REC22105

MOTORES / ENGINES / MOTORI

MD30  
TMD30A  
TAMD30A  
AD30A  
AQAD30A

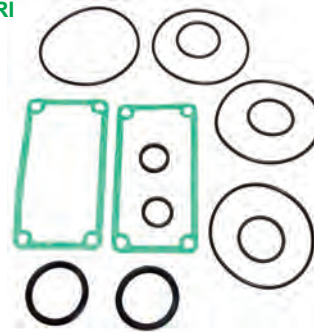

Ref. R.O.  
OEM

REC22106

MOTORES / ENGINES / MOTORI

MD40A  
TMD40A  
AQD40A



Ref. R.O.  
OEM

REC22107

MOTORES / ENGINES / MOTORI

AQD40B  
TMD40B, C  
AQAD40A, B  
TAMD40A, B

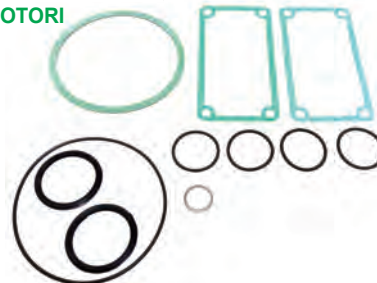

Ref. R.O.  
OEM

REC22108

MOTORES / ENGINES / MOTORI

TMD31A, 31B, 41B  
TAMD31A, 31B, 41B  
AD31A, 31B, 41B  
D41B, A



Ref. R.O. OEM

REC22109

**MOTORES / ENGINES / MOTORI**  
 TMD31L-A, 41L-A  
 TAMD31P-A, L-A, M-A  
 TAMD41P-A, L-A, M-A, H-A  
 AD31P-A, L-A  
 AD41P-A, L-A  
 D41L-A  
 KAD32P, P-A  
 KAD43P, P-A  
 KAD44P, P-A, P-B, P-C  
 KAD300A  
 KAMD300A



**INTERCOOLER**

Ref. R.O. OEM

REC22103

**MOTORES / ENGINES / MOTORI**  
 AQ120B, 125, 140, 145  
 BB140A, 145A



Ref. R.O. OEM

REC22015

**MOTORES / ENGINES / MOTORI**  
 AQ131, 151, 171  
 230, 250, 251

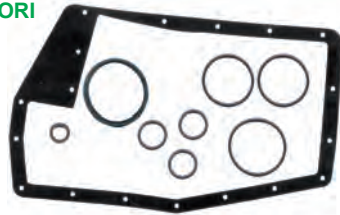

**AFTERCOOLER**

Ref. R.O. OEM

REC22111

**MOTORES / ENGINES / MOTORI**  
 AQAD40A, B  
 TAMD40A, B

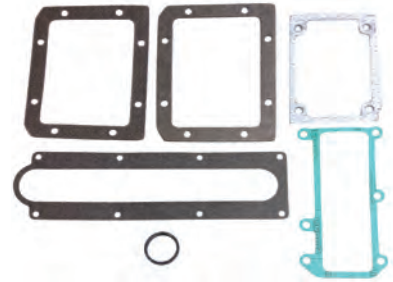

Ref. R.O. OEM

REC22154

**MOTORES / ENGINES / MOTORI**  
 D22  
 TAMD22P-B

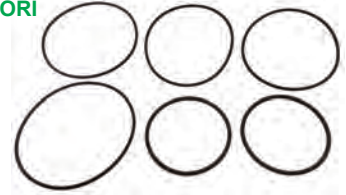

Ref. R.O. OEM

REC22110

**MOTORES / ENGINES / MOTORI**  
 AQAD30A  
 TAMD30A

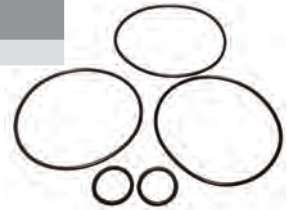

**ENFRIADOR DE AIRE  
 AFTERCOOLER  
 REFRIGERATORE ARIA**

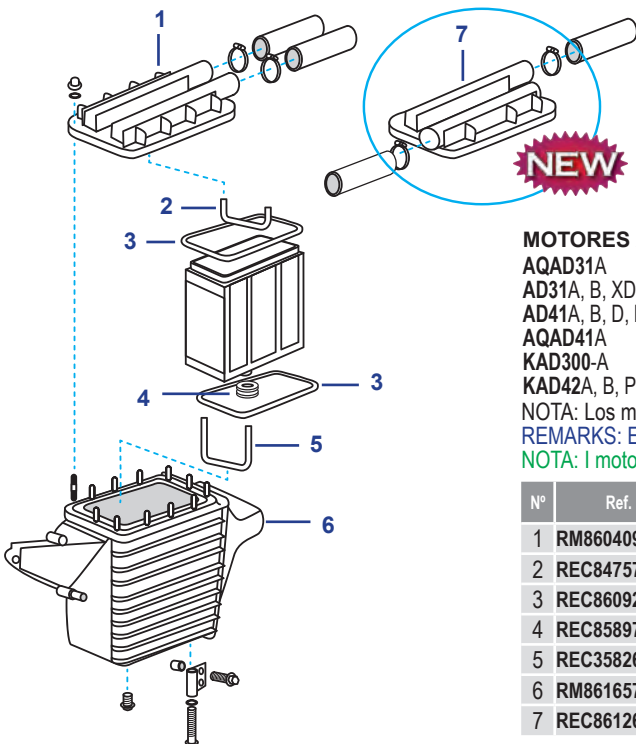

**MOTORES / ENGINES / MOTORI**

AQAD31A	KAD43P	S-A
AD31A, B, XD, D-A, L-A, P-A	KAD44P	TAMD41A, B, D, H-A, H-B, P-A,
AD41A, B, D, L-A, P-A	KAMD300-A	L-A, M-A
AQAD41A	KAMD42A, B, P-2	TAMD42B
KAD300-A	KAMD44P-A, P-C	TAMD42WJ-A
KAD42A, B, P-A	TAMD31A, B, D, L-A, P-A, M-A,	

NOTA: Los motores 44 y 300 utilizan la misma carcasa pero diferente elemento y tapa.

REMARKS: Engines 44 & 300 uses same housing but different insert and cover.

NOTA: I motori 44 e 300 montano la stessa carcassa, ma differente elemento e coperchio.

Nº	Ref.	R.O. OEM	Descripción	Description	Descrizione
1	RM860409	860409	TAPA	COVER	COPERCHIO
2	REC847573	847573	JUNTA	GASKET	GUARNIZIONE
3	REC860920	860920	JUNTA	GASKET	GUARNIZIONE
4	REC858979	858979	JUNTA	GASKET	GUARNIZIONE
5	REC3582639	3582639	JUNTA	GASKET	GUARNIZIONE
6	RM861657	861657	CARCASA	HOUSING	CARCASSA
7	REC861263	861263	TAPA 44/300	COVER 44/300	COPERCHIO 44/300

**AIRCOOLER**



Ref.	R.O. OEM
REC23048	

**MOTORES / ENGINES / MOTORI**

D4-180I-F, I-B, I-C, I-D, I-E  
 D4-210A-A, I-A, I-B  
 D4-225A-F, I-F, A-B, I-B, A-C, A-D, I-C, I-D, A-E, I-E  
 D4-260A-F, D-F, I-F, A-A, A-B, A-C, A-D, D-B, D-C, D-D, I-A, I-B, I-C, I-D, D-E, I-E, A-E  
 D4-300A-F, D-F, I-F, A-A, A-C, A-D, D-A, D-C, I-A, I-C, I-D, A-E, D-E, D-D, I-E  
 D6-280A-A, A-B, A-C, A-D, A-E, I-A, I-B, I-C, I-D, I-E  
 D6-310I-A, A-A, A-B, A-C, A-D, D-B, D-C, D-D, I-B, I-C, I-D, A-E, D-E, I-E

D6-330A-B, A-C, A-D, D-B, D-C, D-D, I-B, I-C, I-D, A-E, D-E, I-E  
 D6-350A-A, A-B  
 D6-370A-B, A-C, A-D, D-B, D-C, D-D, I-A, I-B, I-C, I-D, A-E, D-E, I-E  
 D6-400A-E  
 D6-435D-A, D-D, D-C, D-E, I-A, I-C, I-D, I-E

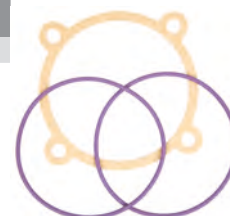

**KIT RETENES ENFRIADOR ACEITE  
OIL COOLER SEAL KIT  
KIT TENUTE REFRIGERATORE OLIO**

Ref.	R.O. OEM
REC22070	

**MOTORES / ENGINES / MOTORI**  
 AQ105, 115, 120, 130, 145, 151, 165A, 170, 171  
 BB115, 140, 145, 165, 170  
 MB20A, B, C  
 230A, B  
 250A, B  
 251A



Ref.	R.O. OEM
REC22128	

**MOTORES / ENGINES / MOTORI**  
 MD29, 29A 32A  
 AQD29A, 32A

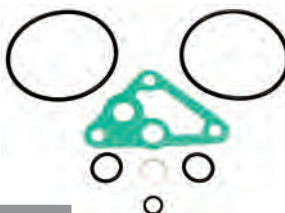

Ref.	R.O. OEM
REC22127	

**MOTORES / ENGINES / MOTORI**  
 MD21A, B  
 AQD21A, B



Ref.	R.O. OEM
REC22153	

**MOTORES / ENGINES / MOTORI**  
 D22  
 MD22L-B, P-B  
 TAMD22P-B  
 TMD22B

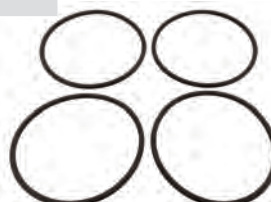

Ref.	R.O. OEM
REC22152	

**MOTORES / ENGINES / MOTORI**  
 D22, 30, 31, 32, 40, 41, 42, 43

Ref.	R.O. OEM
REC22104	

**MOTORES / ENGINES / MOTORI**  
 Para tapa de enfriador con 4 tornillos  
 4 bolt oil cooler cap  
 Per modello con 4 viti  
 MD30, 31, 40, 41, 42, 43, 44, 300



Ref.	R.O. OEM
REC22143	

**MOTORES / ENGINES / MOTORI**  
 Para tapa de enfriador con 3 tornillos  
 3 bolt oil cooler cap  
 Per modello con 3 viti  
 KAD32P-A, 42P-A, 43P-A, 44P-A, 300A  
 KAMD42P-A, 43P-A, 44P-A, 300A  
 TAMD42WJ-A  
 D31, 32, 41, 42, 43, 44, 300

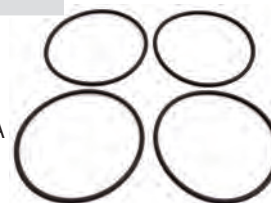

Ref.	R.O. OEM
REC22022	

**MOTORES / ENGINES / MOTORI**  
 Con circuito de agua dulce  
 With fresh water cooling system  
 Con circuito ad acqua dolce  
 2003T, TB



Ref.	R.O. OEM
REC22149	

**MOTORES / ENGINES / MOTORI**

D30, 31, 32, 40, 42, 43  
 D41, A, B, D, L-A  
 AD30A, 40B  
 AD31A, B, D, L-A, P-A, XD  
 AD41AM, L-A, P-A  
 AQAD30A, 31A, 40A, 41A  
 AQD40AM  
 MD30AM, 31, 40A  
 TAMD30A, 40A, 42B, 42WJ-A  
 TAMD31A, L-A

TAMD41A, B, D, H-A, L-A, M-A, P-A  
 TMD30A, 31A, 40A  
 TMD41A, B, D, L-A  
 KAD32P-A, 43P-A, 300A  
 KAD42A, B, P-A  
 KAD44P-A, P-B, P-C  
 KAMD42A, B, P-A  
 KAMD43P-A, 300A  
 KAMD44P-A, P-B, P-C  
 KAD44P-A, P-B, P-C





# FILTROS COMBUSTIBLE Y ELEMENTOS FUEL FILTERS AND ELEMENTS FILTRI COMBUSTIBILE E RACCORDI

## FILTRO CON BRACKET FILTER WITH BRACKET FILTRO CON SUPPORTO

Ref.	R.O. OEM	MICRAS MICRON	TOMAS NPTF PORTS FILETTO	FLUJO FLOW FLUSSO
REC24950		28	1/4"	50 GPH
REC24952		10	1/4"	50 GPH

Bracket de Aluminio.  
Con 2 tapones de bronce y 1 tubo de extensión.  
Cast Aluminium Bracket.  
With 2 brass plugs & 1 extension tube.  
Supporto in alluminio.  
Con 2 tappi di bronzo e 1 tubo di estensione.



## BRACKET BRACKET SUPPORTO

Ref.	BRACKET BRACKET SUPPORTO	TOMAS NPTF PORTS FILETTO
REC25000	AL	1/4"
REC25010	INOX / SS AISI316	1/4"
REC25020	AL	3/8"
REC25030	INOX / SS AISI316	3/8"

Con 2 tapones de bronce y 2 tubos de extensión. (2 entradas y 2 salidas).  
With 2 brass plugs and 2 extension tubes. (2 inputs & 2 outputs).  
Con 2 tappi di bronzo e 2 tubi di estensione. (2 ingressi entrata carburante e 2 uscite carburante).



REC25000  
REC25020

REC25010  
REC25030

Ref.	R.O. OEM	MICRAS MICRON	PARA FILTRO FOR FILTER PER FILTRO
REC3850861	3850861 3858736 3857927 3857325	10	REC3862228

Bracket de Aluminio.  
Cast Aluminium Bracket.  
Supporto in alluminio.



**NEW**

## FILTRO COMBUSTIBLE SEPARADOR DE AGUA WATER SEPARATING FUEL FILTER FILTRO SEPARATORE ACQUA-BENZINA

Ref.	R.O. OEM	MICRAS MICRON	ALTURA HEIGHT ALTEZZA
REC24942		10	4 <sup>7</sup> / <sub>16</sub> "
REC35-802893Q01		10	3 <sup>3</sup> / <sub>4</sub> "
REC855686	855686	28	4 <sup>7</sup> / <sub>16</sub> "
REC35-802893Q		25	3 <sup>3</sup> / <sub>4</sub> "
RACPFF5510	855686	10	4 <sup>7</sup> / <sub>16</sub> "

**Recmar®**



REC24942



REC855686



REC35-802893Q01



REC35-802893Q



RACPFF5510

## RÁCORES RACORS RACCORDO

Ref.	ROSCA THREAD PASSO	MANGUERA HOSE TUBO	X BLISTER X SKINPACK X BLISTER
GS31065	1/4" NPT	3/8" = 9.5 mm	2
GS31166	1/4" NPT	5/16" = 7.9 mm	2
GS31155	3/8" NPT	3/8" = 9.5 mm	2
GS31156	3/8" NPT	5/16" = 7.9 mm	2
GS31157	3/8" NPT	1/4" = 6.4 mm	2

Racor 90° fabricado en latón.  
Made in machined brass.  
Raccordo 90° prodotto in ottone

**GOLDENSHIP**



Ref.	ROSCA THREAD PASSO	MANGUERA HOSE TUBO	X BLISTER X SKINPACK X BLISTER
GS31066	1/4" NPT	5/16" = 7.9 mm	2
GS31067	1/4" NPT	3/8" = 9.5 mm	2

Fabricado en latón.  
Made in machined brass.  
Prodotto in ottone

**GOLDENSHIP**



## FILTROS DECANTADORES COMPLETE FUEL FILTERS FILTRI DECANTATORE



	RAC120R-RAC-01	RAC320R-RAC-01	RAC320R-INOX-01	RAC320R-RAC-02
FLUJO MÁXIMO MAX. FLOW FLUSSO MASSIMO	114 l/h 30 gph	340 l/h 60 gph	340 l/h 60 gph	340 l/h 60 gph
ELEMENTO / ELEMENT / ELEMENTO	<b>RACS3240</b>	<b>RACS3213</b>	<b>RACS3213</b>	<b>RACS3220UL</b>
CAZOLETA TRANSPARENTE (sólo se recomienda para fueraborda.) CLEAR BOWL (Just for outboards) VASCHETTA TRASPARENTE (Solo nei fuoribordo.)	✓	✓	✓	✗
ROSCAS CENTRALES CENTRAL THREADS FILETTO CENTRALE	M18 x 1.5	1 1/4"	1 1/4"	1 1/4"
TAMAÑO ROSCA CABEZA HEAD PORT SIZE DIMENSIONE VITE TESTA	1/4-18 NPTF	1/4-18 NPTF	1/4-18 NPTF	1/4-18 NPTF
ALTURA X ANCHO X PROF. HEIGHT X WIDTH X DEPTH ALTEZZA X LARGH X PROF.	16 x 81 x 81 mm	238 x 102 x 102 mm	238 x 102 x 102 mm	238 x 102 x 102 mm
PESO / WEIGHT / PESO	0,5 kg	0,9 kg	0,9 kg	0,9 kg
CAIDA DE PRESIÓN PRESSURE DROP CADUTA DI PRESSIONE	0.15 PSI 0.01 bar	0.61 PSI 0.04 bar	0.61 PSI 0.04 bar	0.61 PSI 0.04 bar
PRESIÓN MÁXIMA MAX. PRESSURE PRESSIONE MASSIMA	7 PSI 0.05 bar	7 PSI 0.05 bar	7 PSI 0.05 bar	7 PSI 0.05 bar
DESAMONTAJE CARTUCHO-CAZOLETA ELEMENT REMOVAL UNDERBOWL RIMOZIONE DELLA CARTUCCIA	25,4 mm 1"	25,4 mm 1"	25,4 mm 1"	25,4 mm 1"
TEMPERATURA DE TRABAJO OPERATING TEMPERATURE TEMPERATURA DI LAVORO			-40°C +124°C -40°F +255°F	

### ELEMENTOS DE RECAMBIO ELEMENT ELEMENTI DI RICAMBIO

Ref.	MICRAS MICRON	FILTRO FILTER FILTRO
RACS3240	10	RAC120R-RAC-01
LENS3240		
RACS3227	10	
LENS3227		
RACS3213	10	RAC320R-RAC-01 RAC320R-RAC-01 INOX
LENS3213		
RACS3214		
RACS3228UL		RAC320R-RAC-02, con/with/con bracket RACOR
RACS3220UL		RAC320R-RAC-02



LENS3240  
LENS3227  
LENS3213



RACS3240  
RACS3227  
RACS3214



RACS3228UL  
RACS3220UL

## FILTRO GASOLINA FUEL FILTER FILTRO BENZINA



Ref.	R.O. OEM
REC982230	877765 855952 841054

### MOTORES / ENGINES / MOTORI

AQ120B, 125, 131, 151, 171, 175A  
AQ200C, D  
AQ225B, C, D, E, F  
230, 250, 251, 280A, 290A  
255A, B  
260A, B, C, AV



Ref.	R.O. OEM
RACS3228UL	857633



Ref.	R.O. OEM	MICRAS MICRON	
REC3862228	3862228	10	Original Original Originale
RM3862228	3852413 3851218		

**MOTORES / ENGINES / MOTORI**  
4.3, 5.0, 5.7, 5.8, 7.4, 8.1, 8.2L



Ref.	R.O. OEM	MICRAS MICRON	
REC855686	855686	28	Original Original Originale
RM855686-2			

**MOTORES / ENGINES / MOTORI**  
3.0, 4.3, 5.0, 5.7, 8.1, GXI  
430, 431, 432, 434, 500, 501, 570, 571, 572, 740  
AQ205, 200, 211, 225, 231, 271, 311  
BB225, 231, 260, 261



Ref.	R.O. OEM	MICRAS MICRON	PARA BOMBA FOR PUMP PER POMPA
REC3847644	3847644	10	Original Original Originale
RM3847644			

**MOTORES / ENGINES / MOTORI**  
3.0, 4.3, 5.0, 5.7, 8.1, GXI



**FILTROS CARBURADOR  
CARBURATED FILTER  
FILTRO CARBURATORE**



Ref.	R.O. OEM
REC40155	3852224

**MOTORES / ENGINES / MOTORI**  
Ford 5.0 / 5.8 Fi, FS



Ref.	R.O. OEM
REC35-53336	835576

**MOTORES / ENGINES / MOTORI**  
AQ175, 200, 226, 266, 290  
B200, 225, 260



Ref.	R.O. OEM
REC984491	3854019

Rochester



Ref.	R.O. OEM
REC93568	

Carburador Holley 4 cuerpos.  
Holley 4 bbl  
Carburatore Holley 4 corpi



**FILTROS ACEITE  
OIL FILTERS  
FILTRI OLIO**



Ref.	R.O. OEM
REC8692305	8692305

**MOTORES / ENGINES / MOTORI**  
4.3L GL-J, GL-JF, GXI-J, GXI-JF  
5.0L GXI-J, GXI-JF  
5.7L Gi300-J, Gi-300-JF, GXI-J, GXI-JF  
8.1L Gi-J, Gi-JF, GXI-J, GXI-JF (2007+)



Ref.	R.O. OEM	ROSCA THREAD PASSO	
REC3517857	3517857	3/4" x 16 NPT	Original Original Originale
RM3517857	1266286 418432 430143		

**MOTORES / ENGINES / MOTORI**  
AQ60, 90, 95, 100, 105, 110, 120, 125, 130,  
131, 140, 145, 165, 170, 171  
MB20  
BB115, 140, 145, 165, 170  
230A, B  
250A, B  
251A



Ref.	R.O. OEM	ROSCA THREAD PASSO	
REC35-06004	841750	18mm x 1.5	Original Original Originale
RM841750			

**MOTORES / ENGINES / MOTORI**  
AQ175, 205  
430A, B  
431A, B  
432A  
434A  
4.3 GL, GS, GI



Ref.	R.O. OEM	ROSCA THREAD PASSO	
REC35-06003	835440	13/16" x 16 NPT	Original Original Originale
RM835440-9	3852030 3852412		

**MOTORES / ENGINES / MOTORI**  
3.0GL, GS  
AQ200A, B, C, D  
211, 231, 260A, 271, 280A,  
290A, 311  
225A, B, C, D  
500A, B  
501A, B  
570A, 571A, 572A  
740A, B  
4.3, 5.0, 5.7, 8.1 Gi, GL, GXI  
7.4GL, GI, GSI  
8.2GSI



Ref.	R.O. OEM	ROSCA THREAD PASSO
REC35-06007	835779	3/4" x 16 NPT

**MOTORES / ENGINES / MOTORI**  
Con base Ford V8 Bloque pequeño  
V8 Ford small block  
Con base Ford V8 blocco piccolo  
AQ190A, 240A  
5.0FL, FI  
5.8FL, FI, FSI



Ref.	R.O. OEM	ROSCA THREAD PASSO
REC3850559		
RM3850559	3850559	13/16" x 16 NPT

Original  
Original  
Originale



**MOTORES / ENGINES / MOTORI**

- 4.3 GXI, OSI, GL
- 5.0 Gi, GL, OSI, GXI
- 5.7 GS, GSi, GXi, OSI, GL
- 7.4 Gi, GL, GSi
- 8.1 Gi, GSi
- 8.2GL, GSi

**FILTROS MOTOR  
FILTERS ENGINE  
FILTRI MOTORI**



**FILTROS CON CAZOLETA Y ELEMENTOS  
BOWL FILTERS & ELEMENTS  
FILTRI CON VASCHETTA E ELEMENTI**



	RAC500MA30	RAC900MA30	RAC1000MA30	RAC75/500MAX	RAC75/1000MA30
FLUJO MÁXIMO MAX. FLOW FLUSSO MASSIMO	227 l/h 60 gph	341 l/h 90 gph	681 l/h 180 gph	454 l/h 120 gph	681 / 1363 l/h 180 / 360 gph
ELEMENTO ELEMENT ELEMENTO	<b>2010</b>	<b>2040</b>	<b>2020</b>	<b>2010</b>	<b>2020</b>
ALTURA X ANCHO X PROF. HEIGHT X WIDTH X DEPTH ALTEZZA X LARGH X PROF.	292 x 147 x 122 mm	432 x 152 x 178 mm	559 x 152 x 178 mm	292 x 368 x 241 mm	559 x 476 x 279 mm
TAMAÑO ROSCA CABEZA HEAD PORT SIZE DIMENSIONE VITE TESTA	1/4-18 NPTF	1/4-18 NPTF	1/4-18 NPTF	1/4-18 NPTF	
PESO WEIGHT PESO	2 kg	3 kg	5 kg	7,7 kg	13,6 kg
CAIDA DE PRESIÓN PRESSURE DROP CADUTA DI PRESSIONE	0.61 PSI 0.04 bar	0.34 PSI 0.02 bar	0.49 PSI 0.03 bar	0.70 PSI 0.05 bar	3.70 PSI 0.25 bar
PRESIÓN MÁXIMA MAX. PRESSURE PRESSIONE MASSIMA	15 PSI 1 bar	15 PSI 1 bar	15 PSI 1 bar	15 PSI 1 bar	15 PSI 1 bar
ALTURA CLEARN. ALTEZZA	102 mm	127 mm	254 mm	102 mm	254 mm

**ELEMENTOS DE RECAMBIO  
ELEMENT  
ELEMENTI DI RICAMBIO**

REF	R.O. OEM	REF	R.O. OEM	REF	R.O. OEM	MICRAS MICRON
RAC2010SM-OR	1147147	RAC2040SM-OR	889421	RAC2020SM-OR	889425	2
RAC2010TM-OR	861014	RAC2040TM-OR	3838852	RAC2020TM-OR	3838854	10
RAC2010PM-OR	3581760	RAC2040PM-OR	889419	RAC2020PM-OR	889419	30

S: secundario  
T: primario o secundario/final  
P: primario

S: secondary final  
T: primary or secondary final  
P: primary

S: secundario  
T: primario o secundario  
P: primario

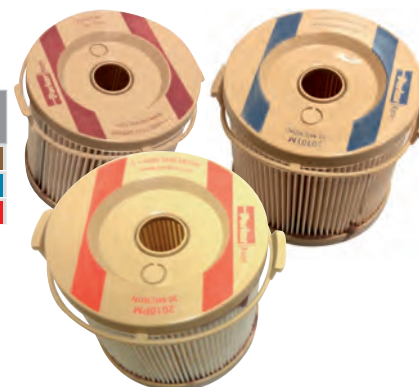

FILTROS DECANTADOR  
COMPLETE FILTER  
FILTRI DECANTATORE



	RAC110A	RAC120AS	RAC230R2	RAC245R2	RAC460R2	RAC490R2
FLUJO MÁXIMO MAX. FLOW FLUSSO MASSIMO	57 l/h 15 gph	57 l/h 15 gph	114 l/h 30 gph	170 l/h 45 gph	227 l/h 60 gph	341 l/h 90 gph
ELEMENTO ELEMENT ELEMENTO	RACR11T	RACR12	RACR20	RACR25	RACR60	RACR90
DIESEL	✓	✓	✓	✓	✓	✓
GASOLINA GAS BENZINA	✓	✓				
CAZOLETA TRANSPARENTE CLEAR BOWL VASCHETTA TRASPARENTE	✗	✓	✓	✓	✓	✓
INSTALACIÓN VACUÓMETRO VACUUM INSTALLATION INSTALLAZIONE VACUOMETRO	✓	✓	✓	✓	✓	✓
INSTALACIÓN PRESIÓN PRESSURE INSTALLATION INSTALLAZIONE PRESSIONE	✓	✓	✓	✓	✓	✓
ALTURA X ANCHO X PROF. (mm) HEIGHT X WIDTH X DEPTH (mm) ALTEZZA X LARGH X PROF. (mm)	152 x 81 x 81	165 x 81 x 81	229 x 102 x 102	267 x 102 x 102	279 x 114 x 121	300 x 114 x 121
PESO WEIGHT PESO	0,59 kg	0,59 kg	0,90 kg	1 kg	1,3 kg	1,4 kg
CAIDA DE PRESIÓN PRESSURE DROP CADUTA DI PRESSIONE	0.15 PSI 0.01 bar	0.15 PSI 0.01 bar	0.31 PSI 0.02 bar	0.61 PSI 0.04 bar	0.39 PSI 0.03 bar	0.95 PSI 0.06 bar
PRESIÓN MÁXIMA MAX. PRESSURE PRESSIONE MASSIMA	100 PSI	7 PSI	30 PSI	30 PSI	30 PSI	30 PSI
TAMAÑO ENTRADA INLET SIZE DIMENSIONI ENTRATA	1/4" NPT	1/4" NPT	1/4" NPT	1/4" NPT	3/8" NPT	3/8" NPT
BOMBA CEBADO (SÓLO PARA DIESEL) PRIMER PUMP (ONLY DIESEL) POMPA (SOLO PER DIESEL)	✗	✗	✓	✓	✓	✓
Nº TOMAS NUM. OF PORTS Nº FORI	4	4	3	3	4	4
TIPO DRENAJE DRAIN TYPE TIPO DRENAGGIO	Sello positivo Positive seal Tenuta positiva	Sello positivo Positive seal Tenuta positiva	Sello positivo Positive seal Tenuta positiva	Sello positivo Positive seal Tenuta positiva	Sello positivo Positive seal Tenuta positiva	Sello positivo Positive seal Tenuta positiva
OPCIÓN SENSOR AGUA WATER SENSOR OPTION OPZIONE SENSORE ACQUA	✗	✓	✓	✓	✓	✓

ELEMENTOS DE RECAMBIO  
ELEMENT  
ELEMENTI DI RICAMBIO

REF.	MICRAS MICROM MICROM
RACR11T	10
RACR12S	2
RACR12T	10
RACR12P	30
RACR20S	2
RACR20T	10
RACR20P	30
RACR24S	2
RACR24T	10
RACR24P	30



REF.	MICRAS MICROM MICROM
RACR25S	2
RACR25T	10
RACR25P	30
RACR26S	2
RACR26T	10
RACR26P	30
RACR60S	2
RACR60T	10
RACR60P	30
RACR90S	2
RACR90T	10
RACR90P	30



S: secundario  
T: primario o secundario/final  
P: primario

S: secondary final  
T: primary or secondary final  
P: primary

S: secondario  
T: primario o secundario  
P: primario

**FILTROS TIPO SEPAR 2000**  
**FILTER TYPE SEPAR 2000**  
**FILTRI DI TIPO SEPAR 2000**

Ref.	MICRAS MICROM	FLUJO FLOW FLUSSO	MEDIDAS MEASURE MISURE	PARA FOR PER
RECGS00530	10	300 l/h	75 x 75 x 24 3 <sup>1</sup> / <sub>16</sub> x 3 <sup>1</sup> / <sub>8</sub> x 1 <sup>3</sup> / <sub>16</sub>	SWK-2000/5/50
RECGS01030	30	600 l/h	88 x 88 x 55 3 <sup>9</sup> / <sub>16</sub> x 3 <sup>5</sup> / <sub>8</sub> x 2 <sup>1</sup> / <sub>8</sub>	SWK-2000/10
RECGS01830	30	1080 l/h	136 x 138 x 55 5 <sup>13</sup> / <sub>16</sub> x 5 <sup>7</sup> / <sub>8</sub> x 2 <sup>1</sup> / <sub>8</sub>	SWK-2000/18/130 (4 units)

**NEW**



**RECMAR®**

**FILTRO COMBUSTIBLE**  
**DIESEL FILTER**  
**FILTRO COMBUSTIBILE**



Ref.	R.O. OEM
REC829913	829913

**MOTORES / ENGINES / MOTORI**

MD5B, C  
 MD1B, 2B  
 MD3B (1995+, 20838+, 22578+)  
 MD7B (3080+)  
 MD11C, D (50884+)  
 MD7C, D (16372+)  
 2001, 2002  
 2003, T, TB



Ref.	R.O. OEM	
REC21139810		
RM21139810	21139810	Original Original Originale

**MOTORES / ENGINES / MOTORI**

D3-110I-D, I-E, I-F  
 D3-140I-E, I-F, A-D, A-E, A-F  
 D3-150I-D, I-E, I-F  
 D3-170I-D, I-E, I-F, A-D, A-E, A-F  
 D3-200I-D, I-E, I-F, A-D, A-E, A-F  
 D3-220I-D, I-E, I-F, A-D, A-E, A-F



Ref.	R.O. OEM	
REC3840335	21624740	
RM3840335	3840335 3588378	Original Original Originale

**MOTORES / ENGINES / MOTORI**

AD41A, B, D  
 AD41P, L-A  
 AMD44P-A, P-B, P-C  
 AQAD40A, B  
 AQAD41A  
 AQD40A, 41A  
 D41A, B, D, L-A  
 KAD300A  
 KAD32P-A  
 KAD42A, 42B, P-A  
 KAD44P-A, P-B, P-C  
 KAMD300A

KAMD42A, B, P-A  
 KAMD43P-A  
 MD22A, B, L-B, P-B  
 MD40A  
 TAMD22A, P-B  
 TAMD40A, B  
 TAMD41A, B, D, P, L,  
 M, H-A, H-B  
 TMD22A, B, P-C  
 TMD40A, B, C  
 TMD41A, B, D, L-A



Ref.	R.O. OEM	
REC861477	861477	
RM861477	21190113 3580096 3841080	Original Original Originale

**MOTORES / ENGINES / MOTORI**

2010A, B, C, D  
 2020A, B, C, D  
 2030A, B, C, D  
 2040A, B, D, D  
 D2-40, 50, 55, 60, 75  
 D1-13, 20



Ref.	R.O. OEM	
RM31261191	31261191 8683212	Original Original Originale

**MOTORES / ENGINES / MOTORI**

D3-110I-A  
 D3-130A-A, I-A  
 D3-160A-A, I-A  
 D3-190A-B



**PRE-FILTRO**  
**PRE-FILTER**  
**PRE-FILTRO**



FILTRO COMPLETO COMPLET FILTER FILTRO COMPLETO	CARTUCHO RECAMBIO REPLACEMENT ELEMENT CARTUCCIA DI RICAMBIO	FLUJO FLOW FLUSSO
REC1140639	REC3581078	50 l/h



**RECMAR®**

FILTRO FILTER FILTRO	CARTUCHO RECAMBIO REPLACEMENT ELEMENT CARTUCCIA DI RICAMBIO	FLUJO FLOW FLUSSO
REC120	RACR12	15 gph



**NEW**

Filtro para gasolina o gasoil.  
 Filter for petrol and diesel.  
 Filtro per benzina o gasolio.

Ref.	R.O. OEM	
REC21492771	21492771 3825133	Original
RM21492771	466987 829993	Original Originale

**MOTORES / ENGINES / MOTORI**

AD31A, B, D, AD, P, L-A  
AQAD30A, 31A  
AQD70C  
D5A-T, A-TA, A-BTA  
D7A-T, A-TA, A-BTA  
KAD32A  
MD30A, B, D, AQ  
MD31A  
MD6A, B  
MD70B  
MD7A, B  
TAMD102A, D  
TAMD122C, D  
TAMD30A, B, D, AQ  
TAMD31A, B, D, P, L,  
M, S-A

TAMD60A, B, C  
TAMD61A  
TAMD62A  
TAMD63L-A, P-A  
TAMD70C  
TAMD71B  
TAMD72P-A, WJ-A  
TAMD73P-A, WJ-A  
TAMD74A-A, A-B, C-A,  
C-B, L-A, L-B, P-A, P-B  
TMD100C  
TMD102KB, KD  
TMD121C, D TMD30A,  
B, D, AQ TMD31A, B,  
D, L-A TMD70C  
TMD75P-A



Ref.	R.O. OEM		SENSOR SENDER SENSORE
REC3583443			
RM3583443	3583443 21718912	Original Original Originale	REC3808616

**MOTORES / ENGINES / MOTORI**

D-4, 6



Ref.	R.O. OEM	
RM3817517	3817517 3839469 3828838	Original Original Originale

**MOTORES / ENGINES / MOTORI**

D9

D11A-A, A-B, A-D  
D12D-A MG, D-A MH, D-B MH, C-A MP,  
D-A MP



Ref.	R.O. OEM
REC876554	876554

**MOTORES / ENGINES / MOTORI**

MD1A, 1B, 2A, 2B, 3B  
MD5A, B (19950+, -20837, -22578)  
MD11C, D (-50883)  
MD17C, D (-16371)



Ref.	R.O. OEM
REC3809721	3809721 21140344

**MOTORES / ENGINES / MOTORI**

D8, 9, 11, 12, 13



Ref.	R.O. OEM
REC22377272	22377272 3888460

**MOTORES / ENGINES / MOTORI**

D8, 9, 11, 12, 13, 16



Ref.	R.O. OEM
REC864315	864315 863750

**MOTORES / ENGINES / MOTORI**

D5

TAMD71, 74, 102, 103, 122, 162, 165



**FILTROS ACEITE  
OIL FILTERS  
FILTRI OLIO**



Ref.	R.O. OEM	
REC834337	834337	
RM834337	22057107 897321	Original Original Originale

**MOTORES / ENGINES / MOTORI**

MD 1B, 2A, 2B, 3B,  
MD 5A, B, C  
MD 6A, 6B, 7A, 7B  
MD 11C, 11D, 17C, 17D  
2001, 2002, 2003

Inversores HS1, IPS-A, B, C, D, E, F



Ref.	R.O. OEM	
REC3581621	3581621 21549544	Original
RM3581621	861474 861475	Original Original Originale

**MOTORES / ENGINES / MOTORI**

MD21B  
AQD21B



Ref.	R.O. OEM	
REC3827069	21549542	
RM3827069	3827069 829161	Original Original Originale



**MOTORES / ENGINES / MOTORI**  
 MD21A Versión antigua / Old style / Modello vecchio  
 MD21B  
 AQD21B, 32  
 TAMD61, 63, 71, 72, 73, 74

Ref.	R.O. OEM	
REC3517857	3517857	
RM3517857	1266286 418432 430143	Original Original Originale



**MOTORES / ENGINES / MOTORI**  
 MD21A, 22L-B, 30, 31  
 TMD22, 22B, 31, 36  
 TAMD22P-B  
 AQD21A  
 KAD32

Ref.	R.O. OEM	
REC3840525		
RM3840525	3840525 3589316	Original Original Originale



**MOTORES / ENGINES / MOTORI**  
 D1-30  
 D2-40, 50, 55, 60, 75  
 MD2030A, B, C, D  
 MD2040A, B, C, D

Ref.	R.O. OEM	
REC861473	861473	
RM861473	3808605 861826	Original Original Originale



**MOTORES / ENGINES / MOTORI**  
 D1-13, 20  
 MD2010A, B, C, D  
 MD2020A, B, C, D



Ref.	R.O. OEM	
REC21913334	21913334 21687472	

**MOTORES / ENGINES / MOTORI**  
 D8A1  
 D8A2

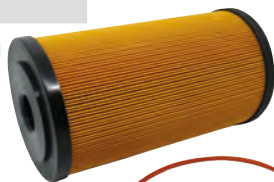

**NEW**

Ref.	R.O. OEM	
REC3831236	3831236 20821230 21640514	

**MOTORES / ENGINES / MOTORI**  
 D5  
 D7



**NEW**



Ref.	R.O. OEM	
REC471034		
RM471034	471034	Original Original Originale



**MOTORES / ENGINES / MOTORI**  
 MD40, 41  
 D70  
 TD30A  
 KAD43P-A  
 KAMD43P-A

Ref.	R.O. OEM	
REC127695-35150		
RM4785974	423135 4785974	Original Original Originale

**MOTORES / ENGINES / MOTORI**  
 KAD42A, 42B, 43, 44  
 KADM42A, 42B, 43, 44  
 TAMD60A, B, C  
 TAMD70B, C, D, E  
 TAMD120A, B  
 MD70A, B, C  
 TMD70A, AB, B, C  
 AQD70B, C, D, BL, CL  
 THAMD70B, C  
 TMD100A, C  
 TMD120A, B, C  
 TMD121C



Ref.	R.O. OEM	
REC21707134		
RM466634	466634 21707134	Original Original Originale

**MOTORES / ENGINES / MOTORI**  
 TAMD61A, 100, 103A, 120B, 122, 122A  
 TMD102, 120B, 121, 122, 122A, 162



Ref.	R.O. OEM	
REC847741		
RM847741	847741	Original Original Originale

**MOTORES / ENGINES / MOTORI**  
 MD61, 62, 63, 71, 72, 73, 74, 75, 102,  
 103, 122  
 D5, 7



Ref.	R.O. OEM	
REC861476		
RM861476	861476 859746	Original Original Originale

**MOTORES / ENGINES / MOTORI**  
 MD22A, L-A,  
 TMD22



Ref.	R.O. OEM	BY-PASS
REC3827069	21549542	✓
RM3827069	3827069	Original
RM3827069	829161	Original
RM3827069	829390	Originale

**MOTORES / ENGINES / MOTORI**  
 61, 63, 71, 72, 73, 74, 75  
 BY-PASS





Ref.	R.O. OEM	BY-PASS
REC3582732		
RM3582732	3582732 22030848	Original Original Originale
REC21632901		✓
RM21632901	21632901 22030852	Original Original Originale

**MOTORES / ENGINES / MOTORI**  
D4, 6



Ref.	R.O. OEM	BY-PASS
REC478736		✓
RM478736	21707133 478736	Original Original Originale

**MOTORES / ENGINES / MOTORI**  
D9, 11, 12, 13, 16,  
TMD102  
TAMD103, 162, 165



Ref.	R.O. OEM	BY-PASS
REC21707132		✓
RM477556	21707132 477556 471392	Original Original Originale

**MOTORES / ENGINES / MOTORI**  
D9, 11, 12, 13, 16  
TAMD103, 162, 165, 193



Ref.	R.O. OEM
REC30788490	30788490

**MOTORES / ENGINES / MOTORI**  
D3-110I-D, I-E, I-F  
D3-140I-E, I-F, A-D, A-E, A-F  
D3-150I-D, I-E, I-F  
D3-170I-D, I-E, I-F, A-D, A-E, A-F  
D3-200I-D, I-E, I-F, A-D, A-E, A-F  
D3-220I-D, I-E, I-F, A-D, A-E, A-F



Ref.	R.O. OEM
REC8692305	8692305

**MOTORES / ENGINES / MOTORI**  
D3-110I-A, B, C  
D3-130I-A, B, C,  
D3-160A-A, B, C,  
D3-160I-A, B, C, (2004 +)  
D3-130A-A, B, C  
D3-190A, B, C,  
D3-190IB, C, (2005 +)



**FILTROS REFRIGERANTE  
COOLANT FILTERS  
FILTRI RAFFREDDAMENTO**



Ref.	R.O. OEM
REC21192875	21192875 20532237 1665251

**MOTORES / ENGINES / MOTORI**  
D9  
D12  
TAMD162, 163, 165



**FILTROS AIRE  
AIR FILTERS  
FILTRI ARIA**



Ref.	R.O. OEM
REC21379288	21379288 21141341

**MOTORES / ENGINES / MOTORI**  
D3



Ref.	R.O. OEM
REC842280	842280

**MOTORES / ENGINES / MOTORI**  
AQAD70C, D  
TMD70C, 100A, 120A, 120B  
TAMD60A, B, C  
TAMD70C, D, E  
TAMD120, 121, 122, 162  
MD70C, 71, 74, 165



Ref.	R.O. OEM	
RM3838952	3838952 3827167	Original Original Originale

**MOTORES / ENGINES / MOTORI**  
TAMD74A-A, A-B, C-A, C-B, L-A, L-B, P-A, P-B,  
TAMD75P-A



Ref.	R.O. OEM
REC21196919	21196919 3885441

**MOTORES / ENGINES / MOTORI**  
D12C-A MP, D-A MH, D-A MP, D-B MH, D-B MP, D-C MH, D-C MP, D-D MP, D-E MH, D-E MP, D-F MP, D-G MH, D-G MP, D-H MP  
D13B-A MP, B-B MP, B-C MP, B-D MP, B-E MH, B-G MP, B-H MP  
D16C-A MH, C-B MH, C-C MH, C-A MG



Ref.	R.O. OEM	Ø
REC21646645	21646645	
RM3582357	21782391 3582358	KIT 165 mm

**MOTORES / ENGINES / MOTORI**  
31, 41  
D3-110I-A  
D3-130I-A  
D3-160I-A  
TAMD42WJ-A



REC21646645

RM3582357



Ref.	R.O. OEM	Ø
REC858488	858488	200 mm

**MOTORES / ENGINES / MOTORI**  
MD31, 41  
TAMD42B, WJ-A



Ref.	R.O. OEM
REC3825038	3825038

**MOTORES / ENGINES / MOTORI**  
TAMD63L-A, L-B, P-A



Ref.	R.O. OEM
REC3580509	3580509

**MOTORES / ENGINES / MOTORI**

D2-50F, 60F  
D2-55A, B, C, D, E, F  
D2-75A, B, C, F  
MD2020B, C, D  
MD2020B (SN 5101311300+)  
MD2030B, C, D  
MD2040A, B, C, D



Ref.	R.O. OEM
REC876185	876185 463505 863344

**MOTORES / ENGINES / MOTORI**

MD30, 40  
KAMD42A, B, PA  
KAD32P-A, 42A, 43P, 300  
KAD44P, A, B, C  
TAMD61A, 62A, 71, 72

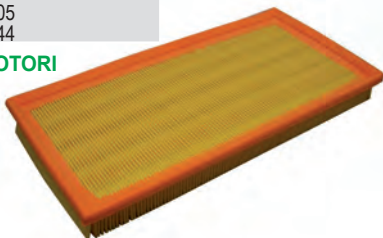

Ref.	R.O. OEM
REC21702999	21702999 3818541 3583654

**MOTORES / ENGINES / MOTORI**  
D-4, 6, 9, 11



Ref.	R.O. OEM
REC21171277	21171277 3889484 3886591 3881586

**MOTORES / ENGINES / MOTORI**

Cuadrado / Square / Quadrato  
D3-110, 130, 160, 190



**FILTROS DESVAPORIZADORES  
DEALERS FILTERS  
FILTRI SFIATO BENZINA**



Ref.	R.O. OEM
REC876069	876069 3830004 876070 849270

**MOTORES / ENGINES / MOTORI**

D12D, 30,31,40,41  
KAD32P  
TAMD61A, 62A, 63, 70, 71A, 72A, 73,  
74, 120, 122, 161, 162, 163,165



Ref.	R.O. OEM	
REC3584145		
RM3584145	3584145	Original Original Originale

**MOTORES / ENGINES / MOTORI**  
D4, 6, 9



Ref.	R.O. OEM
REC21368879	21368879

**MOTORES / ENGINES / MOTORI**

D3-110I-G, I-D, I-E, I-F  
D3-140A-D, A-E, A-F, A-G, I-G, I-E, I-F  
D3-150I-D, I-E, I-F, I-G  
D3-170A-D, A-E, A-F, A-G, I-D, I-E, I-F, I-G  
D3-200A-D, A-E, A-F, A-G, I-D, I-E, I-F, I-G  
D3-220A-D, A-E, A-F, A-G, I-D, I-E, I-F, I-G



**NEW**

**RÁCORES PARA FILTROS  
RACORS FOR FILTER  
RACCORDI PER FILTRO**



Ref.	ROSCA THREAD FILETTO	MANGUERA TUBE TUBO	PARA FILTROS FOR FILTERS PER FILTRI
RAC913-O10-H10	7/8" - 14	5/8" = 16 mm	900 & 1000MA30
RAC913-O10-H8	7/8" - 14	1/2" = 13 mm	900 & 1000MA30
RAC913-O8-H6	3/4" - 16	3/8" = 10 mm	500MA30
RAC913-O8-H8	3/4" - 16	1/2" = 13 mm	500MA30

Fabricado en latón. Para filtros RACOR.  
Made in machined brass. For RACOR filters.  
In ottone. Per filtri RACOR



Ref.	ROSCA THREAD FILETTO	MANGUERA TUBE TUBO	
GS31166	1/4"	5/16" = 7,9 mm	2
GS31155	3/8"	3/8" = 95 mm	2
GS31156	3/8"	5/16" = 7,9 mm	2



**GOLDENSHIP**

Ref.	ROSCA THREAD FILETTO	MANGUERA TUBE TUBO
BRA125-3/16x1/4	1/4"	3/16"
BRA125-1/4x1/2	1/2"	1/4"
BRA125-5/16x3/8	3/8"	5/16"
BRA125-3/8x3/8	3/8"	3/8"
BRA125-3/8x1/2	1/2"	3/8"
BRA125-1/2x3/8	3/8"	1/2"
BRA125-1/2x1/2	1/2"	1/2"
BRA125-1/2x3/4	3/4"	1/2"
BRA125-5/8x3/8	3/8"	5/8"
BRA125-5/8x1/2	1/2"	5/8"
BRA125-5/8x3/4	3/4"	5/8"
BRA125-3/4x1/2	1/2"	3/4"
BRA125-3/4x3/4	3/4"	3/4"
BRA125-1x3/4	3/4"	1"



Ref.	ROSCA THREAD FILETTO	MANGUERA TUBE TUBO
RAC1/2x16	1/2"	16 mm
RAC1/2X18	1/2"	18 mm
RAC1/2X20	1/2"	20 mm
RAC3/8X10	3/8"	10 mm
RAC3/8X12	3/8"	12 mm
RAC3/8X14	3/8"	14 mm

Latón. Para filtros RACOR 500, 900, 1000.  
Brass. For RACOR filters 500, 900, 1000.  
In ottone. Per filtri RACOR 500, 900, 1000.



**RECMAR**

Ref.	ROSCA EXT THREAD EXT FILETTO EST	ROSCA INT THREAD INT FILETTO INT	PARA FILTROS FOR FILTERS PER FILTRI
RAC1/2F-1/2M	7/8"	1/2"	900 & 1000
RAC3/8F-3/8M	3/4"	3/8"	500

Fabricado en latón.  
Made in machined brass.  
In ottone.

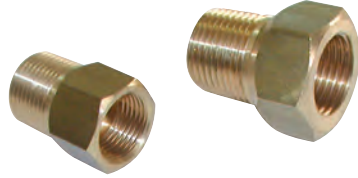

**KITS**

**RECTOS  
STRAIGHT  
DRITTO**

Ref.	MANGUERA TUBE TUBO
GS30430	8 mm
GS30431	10 mm



**ORIENTABLES  
GUIDEBLE  
REGOLABILE**

Ref.	MANGUERA TUBE TUBO	FILTRO FILTER FILTRO
GS30432	8 mm	REC1140639
GS30433	10 mm	



**ACCESORIOS PARA FILTROS  
FILTERS ACCESSORIES  
ACCESSORI PER FILTRI**

**EXTRACTOR DE FILTROS  
OIL FILTER WRENCH  
ESTRATTORE DI FILTRI**

Ref.	PARA FILTROS FOR FILTERS PER FILTRI
REC70720	65 - 110 mm

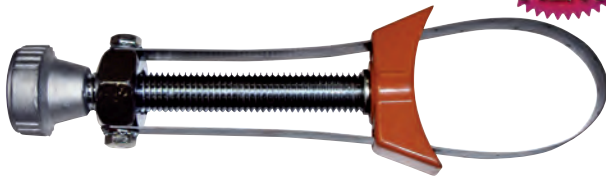

**RELOJ SENSOR DE AGUA  
WATER ALARM  
ALLARME SENSORE ACQUA**

Ref.
RACRK20726



**VALVULA DRENAJE AGUA  
DRAIN VALVE  
VALVOLA DRENAGGIO ACQUA**

Ref.
RACRK19492UL



**SENSOR DE AGUA  
WATER SENSOR  
SENSORE ACQUA**



Ref.
RECRK21069

Sólo para filtros Diesel.  
No utilizar con gasolina.  
Only for diesel applications.  
Do not use with gasoline.  
Solo per filtri Diesel.  
NON benzina



**MANÓMETRO  
VACUUM GAUGE  
MANOMETRO**

Ref.
RAC1606B



# BOMBAS COMBUSTIBLE FUEL PUMP POMPI BENZINA

## BOMBAS MECÁNICAS MECHANICAL PUMP POMPE MECCANICHE

Ref.	R.O. OEM
REC855297	855297 841600



**MOTORES / ENGINES / MOTORI**  
430A  
431A  
AQ205A  
AQ175A



Ref.	R.O. OEM
REC3854053	3854053



**MOTORES / ENGINES / MOTORI**  
Ford 302, 351  
5.0 & 5.8 FLP



Ref.	R.O. OEM	FILTRO FILTER FILTRO
REC8M0073435	3854858	REC35-8M0046752



**MOTORES / ENGINES / MOTORI**  
3.0 GL / GS



Ref.	R.O. OEM
REC3855276	981650 3855276



**MOTORES / ENGINES / MOTORI**  
5.7 GLPMDA, GLIMDA, GLPNCS, GLPLKE,  
GLPLKR, GSPLKD, GSPLKE



Ref.	R.O. OEM
REC826493	826493



**MOTORES / ENGINES / MOTORI**

500, 501, 570, 572  
AQ200, 225, 255, 211, 231, 271, 311, 260, 290



Ref.	R.O. OEM
REC841161	841161



**MOTORES / ENGINES / MOTORI**

AQ120B, AQ140A, BB140A (últimas versiones  
/ early versions / ultime versione)

230A, B  
AQ125B  
AQ131A, B, C, D  
AQ145A, B  
BB145A,  
250A, B  
AQ151A, B, C, D  
AQ171A, C



Ref.	R.O. OEM
REC21134777	21134777 833323



**MOTORES / ENGINES / MOTORI**

MD1B, 2A, 2B, 3B, 5A, 5B, 5C, 6A, 6B, 7A,  
7B, 11C, 11D, 17C, 17D  
2001, 2002, 2003 (-2301)



Ref.	R.O. OEM
REC859428	859428



**MOTORES / ENGINES / MOTORI**

2001, 2002, 2003 (2301+)

AQD2B  
D2A  
MD1B  
MD2A, B  
MD3B  
MD5A, B, C  
MD6A, B  
MD7A, B  
MD11C, D  
MD17C, D



Ref.	R.O. OEM
REC3582500	3582500 3582458 859844



**MOTORES / ENGINES / MOTORI**  
MD22, A, L-A, P-B, L-B  
TMD22A, B, P-C  
TAMD22P-B



Ref.	R.O. OEM
REC21132189	21132189 3584126



**MOTORES / ENGINES / MOTORI**  
D1-13, B, F  
D1-20, B, F  
D1-30, B, F  
D2-40, B, F  
D2-50F  
D2-55, B, C, D, E, F  
D2-60F  
D2-75, B, C



Ref.	R.O. OEM
REC3582310	3582310 860320 1542170



**MOTORES / ENGINES / MOTORI**  
30, 31, 40, 41, 42,  
KAD32D, T  
KAMD44P-A,  
KAD44P-A,  
KAMD300A



Ref.	R.O. OEM
REC3580100	3580100



**MOTORES / ENGINES / MOTORI**  
2010, 2020, 2030, 2040, A, B, C, D  
D2-55A, B, C, D, E, F



**BOMBAS ELÉCTRICAS ALTA PRESIÓN  
HIGH PRESSURE ELECTRIC PUMP  
POMPE ELETTRICHE ALTA  
PRESSIONE**

Ref.	R.O. OEM	PARA BOMBA FOR PUMP PER POMPE
RM3588865	3588865	RM21608511



**MOTORES / ENGINES / MOTORI**  
GX1, GI Moderno 4.3, 5.0, 5.7, 8.1  
4.3GIPEFS  
5.0GIPEFS  
5.7GSIPEFS  
7.4GIPEFS, GSIPEFS  
8.2GSIPEFS



Ref.	R.O. OEM	PARA BOMBA FOR PUMP PER POMPE
REC8865		RM21608511



**MOTORES / ENGINES / MOTORI**  
Kit bomba con tóricas y conector  
Pump kit with o-ring and conector  
Kit pompa con anelli e connettore



Ref.	R.O. OEM
REC3857650	3857650

**MOTORES / ENGINES / MOTORI**

4.3, 5.0, 5.7,  
7.4 GI (sobre bracket / on bracket / su bracket: REC3850861)  
5.0, 5.8 FI, FS (Ford)  
120 PSI (Ford sobre enfriador / on cooler / dispositivo di raffreddamento)



Ref.	R.O. OEM
REC3817328	3817328



8.1GI, GX1 (modernos / Moderns / Moderno)  
8.1 IPS  
3.0 GXIC-J, CXI-J



**BOMBAS ELÉCTRICAS BAJA PRESIÓN**  
**LOW PRESSURE ELECTRIC PUMP**  
**POMPE ELETTRICHE BASSA**  
**PRESSIONE**

Ref.	R.O. OEM	
REC3858261	3858261 3857986 3850809	8 PSI 25 gpm

**MOTORES / ENGINES / MOTORI**

4.3, 5.0, 5.7, 7.4 GI, GL  
 5.0, 5.8FI, FL (Ford)  
 (sobre bracket / on bracket / su bracket:  
 REC3850861)



Ref.	R.O. OEM	
REC3858714	3858714	8 PSI 45 gpm

**MOTORES / ENGINES / MOTORI**

4.3, 5.0, 5.7, 7.4 GI, GL  
 5.0, 5.8FI, FL (Ford)  
 (sobre bracket / on bracket / su bracket: REC3850861)  
 GM Bloque grande / GM Big block / GM Blocco grande



Ref.	R.O. OEM	PARA BOMBA FOR PUMP PER POMPE
REC8845		RM21608511



**KIT BOMBA DE COMBUSTIBLE**  
**ALTA PRESIÓN**  
**HIGH PRESSURE FUEL PUMP KIT**  
**KIT POMPA BENZINA ALTA**  
**PRESSIONE**

Ref.	R.O. OEM
RECEFP-KT	



Ref.	R.O. OEM	FILTRO FILTER FILTRO
RM21608511	21608511 21545138 3594444 3860210 3861355	REC3847644

**MOTORES / ENGINES / MOTORI**

GXI, GI Moderno 4.3, 5.0, 5.7, 8.1  
 4.3GIPEFS  
 5.0GIPEFS  
 5.7GSIPEFS  
 7.4GIPEFS, GSIPEFS  
 8.2GSIPEFS



Ref.	R.O. OEM		
CARP74021		12 V	4-6PSI 20-30 GPH

**MOTORES / ENGINES / MOTORI**

Poseen todas las medidas de seguridad exigidas. De gran capacidad. Sirve para la mayoría de motores marinos a gasolina. Puede usarse para trasvase de gasoil.

Listed by Marine Division UL. High capacity, solid state. Fits most marine gasoline engines. Used for diesel fuel transfer.

Possiede tutte le misure di sicurezza necessarie. Alta capacità. Si può utilizzare per la maggior parte dei motori a benzina. Si può usare per travasi di gasolio.



# INYECTORES INJECTORS INIETTORI



Ref.	R.O. OEM
REC885176	3858969



**MOTORES / ENGINES / MOTORI**  
4.3, 5.0, 5.7 GI, GXI



Ref.	R.O. OEM
REC3855182	3855182

**MOTORES / ENGINES / MOTORI**  
5.7GLPMDA, GIPMDA, GIPMDACE, GLIMDA, GIIMDA, GIPHUS, GLPNCS, GIPNCACE, GIPNCSCE, GIPNCMCE, GIPNCBCE, GIINCCCE, GIINCSCCE, GLPLKA, GLPLKD, GLPLKE, GLPLKR, GSPLKE, GSPLKE, GLIPLKDCE, GIPLKDCE, GIPLKECE, GSICPLKD, GSIPLK  
4.3GLPHUB, GSPHUB, GSPHUS, GIPHUSCE, GLPNCA, GLPNCB, GLPNCS, GSJNCC, GSJNCS, GSPNCA, GSPNCB, GSPNCM, GSPNCS, GIPNCACE, GIPNCBCE, GLPLKD, GLPLKE, GSPLKD, GSPLKE, GIPLKDCE, GIPLKECE, GSJLKD, GLPBYC, GSPBYC, GIPBYCCE, GSJBYA, GIJBYA (1994-07)



Ref.	R.O. OEM
REC3858941	3858941

**MOTORES / ENGINES / MOTORI**  
4.3GX1-A, GLPWTC, GLPWTR, GSPWTC, GSPWTR, GIPWTC, GIPWTR, GIJWTR, GSJWTR, GLPEFS, GIPEFS  
TBI

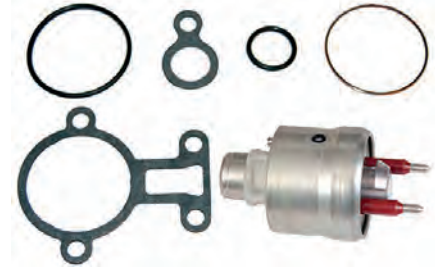

**KIT RETENES INYECTOR  
FUEL INJECTORS SEAL KIT  
KIT TENUTE INIETTORI**

Ref.	R.O. OEM
REC853998A1	

**MOTORES / ENGINES / MOTORI**  
GM V6 & V8



# INYECTORES INJECTORS INIETTORI



Ref.	R.O. OEM
REC859494	859494

**MOTORES / ENGINES / MOTORI**  
AD31B, D, XD  
D31L-A  
AD41B, D,  
D41B  
TAMD31B, D, L-A, M-A, P-A, S-A  
TAMD41B, D, H-A, H-B, L-A, M-A, P-A  
TMD31B, D, L-A  
TMD41B  
AD41L-A, P-A (Indicar nº producto / Indicate product number / Indicare il numero del prodotto )



Ref.	R.O. OEM
REC861103	861103

**MOTORES / ENGINES / MOTORI**  
AD31P-A  
AD41D  
D41D, L-A  
KAD42A, B, P-A  
KAD43P-A  
KAMD42A, B, P-A  
KAMD43P-A  
TAMD31P-A  
TAMD41D, H-A, H-B, L-A, M-A, P-A  
TAMD42B, WJ-A  
TMD41D, L-A  
AD41L-A, P-A (Indicar nº producto / Indicate product number / Indicare il numero del prodotto )



Ref.	R.O. OEM
REC861725	861725

**MOTORES / ENGINES / MOTORI**

KAD44P-A, P-B, P-C  
KAMD44P-A, P, P-C



Ref.	R.O. OEM
REC3581696	3581696

**MOTORES / ENGINES / MOTORI**

KAD32P



Ref.	R.O. OEM
REC3583073	3583073

**MOTORES / ENGINES / MOTORI**

KAD300A,  
KAMD300-A



**KIT CAMISA INYECTOR  
INJECTOR SLEEVE KIT  
KIT CAMICIA INIETTORE**

Ref.	R.O. OEM
REC861255	861255

**MOTORES / ENGINES / MOTORI**

AD31A, B, D, L-A, XD  
AD41A, B, D, L-A, P-A  
AQAD31A  
AQAD41A  
D41A, B, D, L-A  
KAD42A, B, P-A  
KAD43P-A  
KAMD42A, B, P-A  
KAMD43P-A  
MD31A  
TAMD31A, 31B, D, L-A, M-A  
TAMD41A, B, D, H-A, H-B, L-A, M-A, P-A  
TAMD42B, WJ-A  
TAMDS31B TD31ACE,  
TMD31A, B, D, L-A  
TMD41A, B, D, L-A



Ref.	R.O. OEM
REC889970	889970

**MOTORES / ENGINES / MOTORI**

D4-180I-B, I-C, I-D, I-F  
D4-210A-A, I-A, I-B  
D4-225A-B, I-B, A-C, A-D, I, A-F, I-F  
D4-260A-F, D-F, I-F  
D4-300A-F, D-F, I-F  
D6-280A-A, A-B, A-C, A-D, A-E, I-A, I-B, I-C, I-D, I-E  
D6-310I-A, A  
D6-300A-F, D-F, I-F, A-F  
D6-330A-F, D-F, I-F  
D6-370A-F, D-F, I-F  
D6-400A-F  
D6-435D-F



Ref.	R.O. OEM
REC3581536	3581536

**MOTORES / ENGINES / MOTORI**

AD31L-A, P-A  
AD41L-A, P-A  
D41L-A  
KAD32P-A  
KAD43P-A  
KAMD43P-A  
TAMD31L-A, M-A, P-A, S-A  
TAMD41H-A, H-B, P-A, L-A, M-A  
TAMD42WJ-A  
TMD31L-A  
TMD41L-A



Ref.	R.O. OEM
REC861688	861688

**MOTORES / ENGINES / MOTORI**

KAD44P-A, P-B, P-C  
KAMD44P-A, P-C  
KAD300-A  
KAMD300-A



**KIT JUNTAS SISTEMA COMBUSTIBLE  
GASKET KIT, FUEL SYSTEM  
KIT GUARNIZIONE, SISTEMA  
COMBUSTIBILE**

Ref.	R.O. OEM
REC1302	

**MOTORES / ENGINES / MOTORI**

AQAD41A  
AQD41A  
MD41B, L-A  
KAD42A  
KAD43P  
KAMD42A  
KAMD43P-A  
TAMD41A, B, P-A, L-A, M-A, H-A  
TMD41A, B, L-A



**ESTABILIZADOR GASOLINA - DIESEL  
FUEL - DIESEL STABILIZER  
STABILIZZATORE BENZINA - DIESEL**

GE22207  
GE22254



**LIMPIADOR DE INYECTORES  
FUEL INJECTOR CLEANER  
PULITORE INIETTORE**

GE21204  
GE15210





# CARBURADORES CARBURETORS CARBURATORI

Ref.	R.O. OEM	KIT REPARACIÓN REPAIR KIT KIT RIPARAZIONE	CUERPOS BBL CORPI
RM21610333	21610333 21132437 3857982 3854086	REC21533394	

**MOTORES / ENGINES / MOTORI**  
3.0L,  
GSP, GSM, GLM, GLP



Ref.	R.O. OEM	KIT REPARACIÓN REPAIR KIT KIT RIPARAZIONE	CUERPOS BBL CORPI
MP426422	3858331 3859066 3854346 21610334	REC3854020	2

**MOTORES / ENGINES / MOTORI**  
500 CFM



Ref.	R.O. OEM	KIT REPARACIÓN REPAIR KIT KIT RIPARAZIONE	CUERPOS BBL CORPI
MP426434	3850288 3858333	REC1396-5238	4

**MOTORES / ENGINES / MOTORI**  
4.3L GS  
600 CFM



Ref.	R.O. OEM	KIT REPARACIÓN REPAIR KIT KIT RIPARAZIONE	CUERPOS BBL CORPI
RM3850245	3850245	REC3854020	2

**MOTORES / ENGINES / MOTORI**  
5.7, GLP, GLI



Ref.	R.O. OEM	KIT REPARACIÓN REPAIR KIT KIT RIPARAZIONE	CUERPOS BBL CORPI
MP426574	3855279		4

**MOTORES / ENGINES / MOTORI**  
5.7 GSP  
600 CFM



Ref.	R.O. OEM	KIT REPARACIÓN REPAIR KIT KIT RIPARAZIONE	CUERPOS BBL CORPI
MP426766	3855957	REC3854105	4

**MOTORES / ENGINES / MOTORI**  
7.4L & 8.2L  
750 CFM



**ADAPTADOR HOLLEY  
HOLLEY ADAPTOR  
ADATTATORE HOLLEY**

Ref.	R.O. OEM
REC2696	



**KIT ADAPTADOR HOLLEY  
ADAPTER KIT HOLLEY  
KIT ADATTATORE DA ROCHESTER A HOLLEY**

Ref.	R.O. OEM
RECHOL17-6	

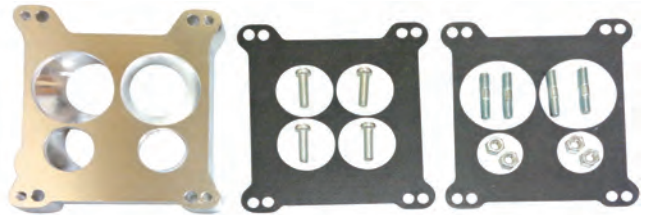

**HOLLEY**

Ref.	R.O. OEM	CUERPOS BBL CORPI
REC27-65577	27-65577	4
REC27-41609	27-41609	4
REC27-70142	27-70142	2
REC27-60715	27-60715	2

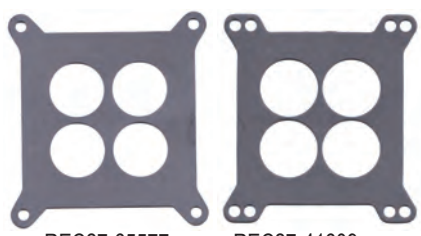

REC27-65577

REC27-41609



REC27-70142

REC27-60715

**KIT TORNILLOS CARBURADOR  
CARBURETOR STUD KIT STD  
KIT VITERIA CARBURATORE**

Ref.	R.O. OEM	ROSCA THREAD PASSO	LONGITUD LONG LUNGHEZZA
REC9-35176		5/16"	1 3/8"



**JUNTAS  
GASKET  
GUARNIZIONE**

Ref.	R.O. OEM
REC27-8079821	841031

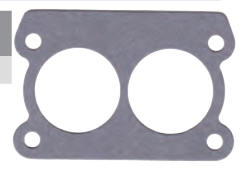

Ref.	R.O. OEM
REC824677	824677

SOLEX Carburetor



Ref.	R.O. OEM
REC3853283	3853283

**MOTORES / ENGINES / MOTORI**  
3.0 GS, GL  
4.3 GL-P, J, JF

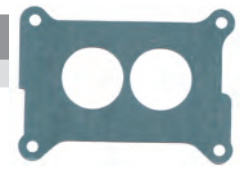

**BOYAS  
FLOATS  
GALLEGGIANTI**

Ref.	R.O. OEM
REC1397-3327	

**MOTORES / ENGINES / MOTORI**  
305" (5.0L) AQ260A, B  
307" (5.0L) 290A  
350" (5.7L) 501A  
454" (7.4L) 501A/MS4A  
AQ225B, C, D, E, F 570/S4A  
AQ255A, B



Ref.	R.O. OEM
REC3302-9031	

**MOTORES / ENGINES / MOTORI**  
AQ175A  
AQ200D, F  
AQ500A



Ref.	R.O. OEM
REC3854018	3854018



**TUBO COMBUSTIBLE BOMBA  
A CARBURADOR  
FUEL TUBE FROM PUMP  
TO CARBURETOR  
TUBO CARBURANTE DA POMPA A  
CARBURATORE**

Ref.	R.O. OEM	
REC18-8115		3/8"x25" - 5/8"
REC18-8114		3/8"x31" - 5/8"



**GUÍA KITS CARBURADOR Y BOYAS  
CARBURETOR & FLOATS APPLICATION  
GUIDA KIT CARBURATORE E GALLEGGIANTI**

Modelo Model Modello	Cyl	CÓDIGO CODE CORPI	CARBURADOR CARBURETOR CARBURATORE	KIT REPARACIÓN SERVICE KIT KIT RIPARAZIONE	BOYAS FLOAT GALLEGGIANTI
AQ115A, B AQ125A, B AQ130C, D	4		SOLEX44 PA-1	REC856472	
AQ131A, B, C, D AQ145A, B			SOLEX44 PA-1	REC856472	
AQ120B AQ140A	4		SOLEX44 PHN-3	REC841294	REC3854018
AQ120A AQ130B	4			REC875407	
3.0L GL, GS, GLP	4	H-2	R-80316A, 1A	REC21533394	
AQ170A, B, C	6		SOLEX44 PA-1	REC856472	
AQ175A	6	R-2	17059059	REC841994	REC3302-9031
4.3L GI, GL, GS	6	H-2	R-80312A -A1	REC3854020	
4.3L GI, GL, GS	6	H-4	R-80403A -A1	REC1396-5238	
AQ200D, F AQ500A	8	R-2	17057133	REC841994	
501A, 501A/MS4A, 570/MS4A	8	R-4	17059283,296,298	REC823426A1	REC1397-3327
5.0L, 5.7L GM	8	R-4		REC823426A1	REC1397-3327
5.0L, 5.8L, FORD	8	H-2	R-80382A-1A	REC1396-4656	
5.0L, 5.8L FORD	8	H-4	R-80383A-1A	REC1396-5238	
740 A/MS5A	8	H-4	R-84026AA	REC76104	
7.4 GM ROCHESTER	8	R-4		REC841994	REC1397-3327
7.4L GL	8	H-4	R-80378A-1A	REC3854105	
8.2L GI	8	H-4	R-80378A-1A	REC3855017	
7.5L FORD	8	H-4		REC985052	

**KITS CARBURADOR  
CARBURETOR KITS  
KIT CARBURATORE**

Ref.	R.O. OEM
REC875407	875407

**MOTORES / ENGINES / MOTORI**  
AQ100, 105A, 110, 115, 120  
AQ130A, B  
AQ165A



Ref.	R.O. OEM
REC841994	841994

**MOTORES / ENGINES / MOTORI**  
AQ175A, 200, 225, 260, 290

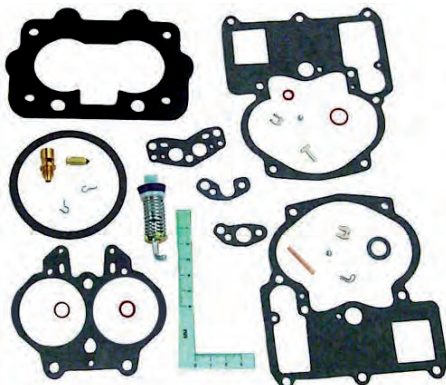

Ref.	R.O. OEM
REC841294	841293

**MOTORES / ENGINES / MOTORI**  
AQ120B, 140A

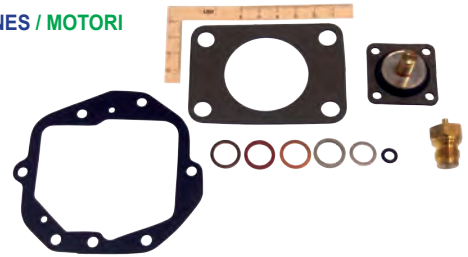

Ref.	R.O. OEM
REC856472	856472

**MOTORES / ENGINES / MOTORI**  
AQ115A, B  
AQ125A, B  
AQ130C, D  
AQ131A, B, C, D  
AQ145A, B  
AQ151A, B, C  
AQ170A, B, C  
AQ171A, C



Ref.	R.O. OEM
REC823426A1	855889

**MOTORES / ENGINES / MOTORI**  
AQ225B, C, D, E, F  
AQ255A, B  
AQ260A, B, AV, C  
AQ290A  
1A501A  
MS4A, 570  
MS4A  
305"(5.0L)  
307"(5.0L)  
350"(5.7L)  
454"(7.4L)

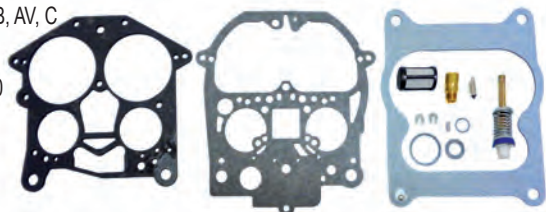

Ref.	R.O. OEM
REC21533394	854256 21533394

**MOTORES / ENGINES / MOTORI**  
3.0 GL, GS



Ref.	R.O. OEM
REC1396-4656	3854106

**MOTORES / ENGINES / MOTORI**  
HOLLEY (2 Cuerpos / 2 bbl / 2 corpi)  
5.0L, 5.8L FORD FI, FL, SX FORD  
HO, MD, NC

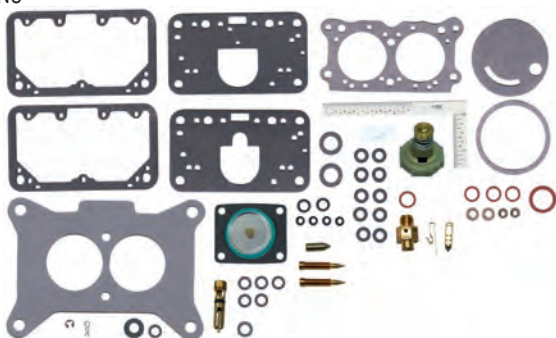

Ref.	R.O. OEM
REC3855017	3855017

**MOTORES / ENGINES / MOTORI**  
8.2L GL HU, MI



Ref.	R.O. OEM
REC3854020	3854020

**MOTORES / ENGINES / MOTORI**  
4.3GL WT, GS WT, GI  
5.0L, GL  
5.7GL



Ref.	R.O. OEM
REC1396-5238	3854107

**MOTORES / ENGINES / MOTORI**  
HOLLEY (4 Cuerpos / 4 bbl / 4 corpi)  
4.3L, GL, GS  
5.0L, 5.8L FORD  
HU, MD, NC



Ref.	R.O. OEM
REC3854105	3854105

**MOTORES / ENGINES / MOTORI**  
7.4L Gi, GL, GSi  
8.2L GSi  
HU, NC, LK, MD

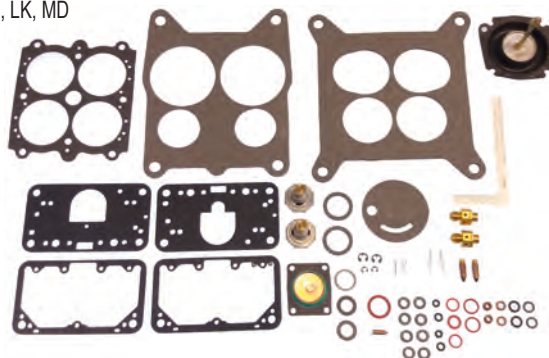

Ref.	R.O. OEM
REC76104	

**MOTORES / ENGINES / MOTORI**  
740A  
MS5A

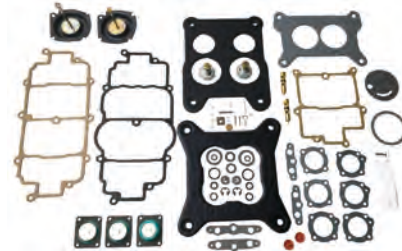

Ref.	R.O. OEM
REC985052	

**MOTORES / ENGINES / MOTORI**  
7.5 FORD  
HOLLEY (4 Cuerpos / 4 bbl / 4 corpi)



# TURBOS TURBO TURBINE

	TURBO TURBO TURBINE	R.O. OEM	JUNTA GASKET GUARNIZIONE
TAMD41A, B, D, L-A, H-A, H-B, P-A, M-A TAMD42WJ-A TMD41A, B, D D41A, B, D AQAD41A AD41A, D, B, L-A, P-A KAD42A, B, P-A KAD43P-A KAMD42B, P-A KAMD43P-A	REC861260	861260 3802070 838697 860918 3802061	REC3582563
MD40A TMD40A, B, C TAMD40A, B AD40B AQD40A AQAD40A, B	REC845294	3802033 845294	REC3582595
AD30A AQAD30A MD30, A TAMD30, A TMD30, A	REC846037	3802020 846037	REC3582595
AQAD31A AD31A, B, L-A, P-A AD41D D41D TMD31A, B TAMD31A, B, L-A, M-A TAMD41B, D KAD32P-A	REC3581528	3581528 860916 3802082 838695	REC3582563
KAD300-A KAMD300-A	REC3802125	3802125 3583006	REC3582563



	TURBO TURBO TURBINE	R.O. OEM	JUNTA GASKET GUARNIZIONE
KAMD44P-A, P-C KAD44P, P-B, P-C	REC3802105	3802105 3802112	REC3582563
TAMD22P-B TMD22A, B, P-C	REC3802092	3802092 3581150 861407	RM859834
TAMD71A, B TAMD61A	REC865428	865428 865334 848276 848275 864878 848276	
D3-110I-D, I-E, I-F, I-G, I-H D3-140, 150, 170, 200, 220	REC3801387	3801387	RM3883844
D3-110I-A, I-B, I-C D3-130, 160	REC3801270	3801270 3802145	RM3883844
D3-190	REC3801271	3801271 3802167	RM3883844

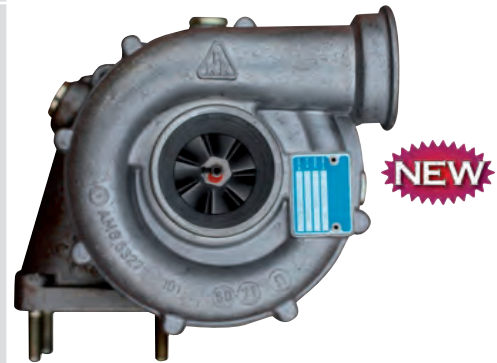

	TURBO TURBO TURBINE	R.O. OEM	JUNTA GASKET GUARNIZIONE
D4-180, 210, 225	REC3802150	3802150	RM3588435
D4-260	REC3802149	3802149	RM3588435
D4-300	REC3801173	3801173	RM3588435
D6-280, 300, 310	REC3802152	3802152	RM3588435
D6-330, 350, 370	REC3802151	3802151	RM3588435
D6-400, 435	REC3801138	3801138	RM3588435



**NEW**



**NEW**



**NEW**



**NEW**



**NEW**



**NEW**

# SENSORES MOTOR INYECCIÓN INJECTION ENGINES SENSORS SENSORI MOTORI INIEZIONE

## TEMPERATURA AIRE AIR TEMPERATURE TEMPERATURA ARIA

Ref.	R.O. OEM	
REC3854158	3854158	

**MOTORES / ENGINES / MOTORI**  
5.0FL, FI  
5.8FL, FSi (1995-96), FI (1994-96)



IAT / MAT

Ref.	R.O. OEM	
REC805223T	3854527	

**MOTORES / ENGINES / MOTORI**  
4.3L EFI  
5.0L Gxi-A (2001-02)  
5.7L GiL-A (2001)  
5.7L Gi-A (2000-01)  
5.7L GSiL-A (2000-01)  
5.7L Gxi-A (2000-01)  
5.7L XiL-A (2000-01)  
5.7L Gxi-B (2001-02)  
7.4L (1994-00) Varios / Many / Varie  
8.1L (2005+) Varios / Many / Varie



## VÁLVULA DE RALENTÍ. IAC IDLE VALVE. IAC VALVOLA DI IDLE. IAC

Ref.	R.O. OEM	
REC3855194	3855194 3855185	

**MOTORES / ENGINES / MOTORI**  
4.3, 5.0, 5.7,  
7.4 GIHUBCE, GIINCCE, GIINCSCCE,  
GIPHUSCE, GIPLKDCCE, GIPLKECE,  
GIPNACE, GIPNCBCE, GIPNCMCE,  
GIPNCSCCE, GSIINCC, GSIXHUS, GSIXNCB  
8.2 GSIXNCB  
DPX385XLKE, 415XLKE



Ref.	R.O. OEM	
REC3843751	3843751 3857696	

**MOTORES / ENGINES / MOTORI**  
4.3GXIE-M, P, Q, 225-R  
7.4 GI  
8.1 GI, GXI  
V6-225-E-A  
Se instala en el cuerpo de mariposa  
Installs on the butterfly body  
Si nstalla sul corpo farfalla



## SENSOR AVISADOR DE TEMPERATURA DEL AGUA WATER TEMPERATURE WARNING SENSOR SENSORE DI AVVERTIMENTO DELLA TEMPERATURA DE L'ACQUA

Ref.	R.O. OEM		
REC873066	873066	97°	

**MOTORES / ENGINES / MOTORI**  
D31, 32, 41, 42, 43



## TEMPERATURA AGUA WATER TEMPERATURE TEMPERATURA ACQUA

Ref.	R.O. OEM		
REC3850397	3850397		

**MOTORES / ENGINES / MOTORI**  
D3  
4.3  
5.0  
5.7  
7.4  
8.1



Ref.	R.O. OEM	
REC3854159	3854159	

**MOTORES / ENGINES / MOTORI**  
5.0FI, FSi, FLi  
5.8FI, FSi, FLi

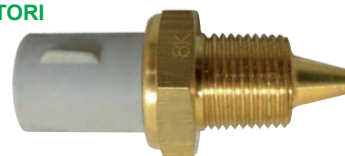

Ref.	R.O. OEM	
REC3862500	3862500	

**MOTORES / ENGINES / MOTORI**  
3.0, 4.3, 5.0, 5.7, 8.1

En codo de escape  
For exhaust elbow  
Per il gomito di scarico



Ref.	R.O. OEM	
REC3853787	3853787	

**MOTORES / ENGINES / MOTORI**  
5.0L FL, FI,  
5.8 FL, FI, FSi



Ref.	R.O. OEM	
REC872066	872066	

**MOTORES / ENGINES / MOTORI**  
3.0, 4.3, 5.0, 5.7L  
(1998-07)

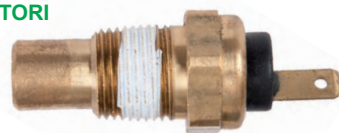

Ref.	R.O. OEM	ESTACIONES STATIONS STAZIONI	
REC827151	827151	40-120°C	1

**MOTORES / ENGINES / MOTORI**  
KAMD42P-A, 43P-A,  
KAD32P, 42P-A, 43P-A  
MD2010C, D  
MD2020C, D  
MD2030C, D  
MD2040C, D  
MD21, 11, 17, 31, 41 30, 40, D2  
AQD21





Ref.	R.O. OEM	ESTACIONES STATIONS STAZIONI	
REC840074	840074	40-120°C	2

**MOTORES / ENGINES / MOTORI**  
D31, 32, 41, 42, 43  
MD1, 2, 3, 7, 11, 17  
AQD2B



**NEW**

Ref.	R.O. OEM		
REC8653103	8653103		

**MOTORES / ENGINES / MOTORI**  
D3-110 --> D3-190



**NEW**

**AGUA EN COMBUSTIBLE  
WATER IN FUEL  
ACQUA NEL COMBUSTIBILE**

Ref.	R.O. OEM		
REC3808616	3808616		

**MOTORES / ENGINES / MOTORI**  
D3, 4, 6



**NEW**

Ref.	R.O. OEM		
REC3588916	3588916 874109		



**MOTORES / ENGINES / MOTORI**  
D1, 2, 3, 4, 6, 9, 12  
31, 30, 41, 42, 43, 44, 300  
MD2010, 2020, 2030, 2040  
MD22



**NEW**

**KIT TEMPERATURA Y PRESIÓN  
DE ACEITE CON ALARMA  
COMPLETE TEMPERATURE & OIL  
PRESSURE WARNING KIT  
KIT TEMPERATURA PRESSIONE  
DELL'OLIO CON ALLARME**

Ref.	R.O. OEM		
REC41400			

**PRESIÓN DE ACEITE  
OIL PRESSURE  
PRESSIONE DELL'OLIO**

Ref.	R.O. OEM		
REC8M0068784	3857532	80 PSI	

**MOTORES / ENGINES / MOTORI**  
3.0, 4.3, 5.0, 5.7, 7.4, 8.1,  
230A, B  
250A, B



**GAS**

Ref.	R.O. OEM		
REC3887328	3887328 3842442		

**MOTORES / ENGINES / MOTORI**  
V6 GI, GXI  
V8 GI, GXI



**GAS** **NEW**

Ref.	R.O. OEM		
REC3852215	3852215		

**MOTORES / ENGINES / MOTORI**  
4 cyl  
V6, V8  
3.0, 4.3, 5.0, 5.7, 7.4, 8.2



**GAS** **NEW**

Ref.	R.O. OEM		
REC1324750	1324750		

**MOTORES / ENGINES / MOTORI**  
MB10, B 18, 20, 30  
AQ120B, 125A, 140A, 145A, 200B,  
210A, 225A, 225B  
MD21A, 21B, 29, 32  
2001, 2002, 2003



**D** **GAS**

Ref.	R.O. OEM		
REC3545696	3545696		

**MOTORES / ENGINES / MOTORI**  
D3-110 --> D3-190



**D** **NEW**

Ref.	R.O. OEM		
REC3808797	3808797		

**MOTORES / ENGINES / MOTORI**  
D1-13, 20, 30  
D2-40, 55C, 60F, 75



**D** **NEW**

Ref.	R.O. OEM		
REC21250645	21250645 3808796		

**MOTORES / ENGINES / MOTORI**  
D1-13, B, F  
D1-30, B, F  
D1-20, B, F  
D2-40, B, F  
D2-55D, E, F  
D2-60F  
D2-75, B, C, F



**D** **NEW**

Ref.	R.O. OEM
REC807078	807078

**MOTORES / ENGINES / MOTORI**  
MD1A, 1B, 2A, 2B, 3B, 5A, 5B, 6A, 6B



Ref.	R.O. OEM	ESTACIONES STATIONS STAZIONI
REC866835	866835	1
REC866836	866836	2

**MOTORES / ENGINES / MOTORI**  
D31, 32, 41, 42, 43, 44, 63, 72, 74, 75, 103, 122, 162, 165  
D12D  
MD2010A. 2020A. 2030A. 2040A



REC866836

REC866835

Ref.	R.O. OEM
REC829587	829587

**MOTORES / ENGINES / MOTORI**  
MD5C, 7A, 7B, 11C, 11D, 17C, 17D

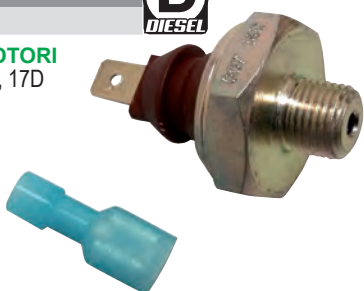

### RAIL DE PRESIÓN PRESSION RAIL PRESSIONE PRESSIONE

Ref.	R.O. OEM
REC3843100	3843100 3884352 3587927

**MOTORES / ENGINES / MOTORI**  
D3, D4, D6



### POTENCIÓMETRO MANDO CONTROL POTENTIOMETER POTENZIOMETRO DI CONTROLLO

Ref.	R.O. OEM
REC1336385	1336385

**MOTORES / ENGINES / MOTORI**  
EDC / EVC



### SENSOR AVISADOR DE PRESIÓN DE ACEITE OIL PRESSURE WARNING SENSOR SENSORE DI AVVERTIMENTO DELLA PRESIONE DELL'OLIO

Ref.	R.O. OEM	0.7 bar
REC863169	863169	0.7 bar



**MOTORES / ENGINES / MOTORI**  
2001, 2002, 2003  
D12D, 31, 32, 40, 41, 42, 43, 44, 60, 61, 71, 72, 73, 74, 75, 100, 102, 103, 120, 121, 122, 162, 300



### SENSOR DE POSICIÓN CIGÜEÑAL CRANKSHAFT POSITION SENSOR SENSORE POSIZIONE ALBERO MOTORE

Ref.	R.O. OEM
REC892617	3808516



**MOTORES / ENGINES / MOTORI**  
8.1L



Ref.	R.O. OEM
REC864297T01	3858979



**MOTORES / ENGINES / MOTORI**  
4.3, 5.0, 5.7L  
Para tapas de distribución de plástico  
For plastic distribution caps  
Per tappi di distribuzione in plastica



Ref.	R.O. OEM
REC21124849	21124849



**MOTORES / ENGINES / MOTORI**  
V6 (modernos / new / nuovi)  
Para tapas de distribución metálicas  
For metallic distribution caps  
Per tappi di distribuzione in metallo



### REGULADOR VOLTAJE SEV MARCHAL VOLTAGE REGULATOR REGOLATORI DI VOLTAGGIO

Ref.	R.O. OEM
REC847605	847605

**MOTORES / ENGINES / MOTORI**  
AQ170C  
MD11A, B, 2B, 3B, 6A, 60, 70, 100, 120  
MB10A



**SENSOR DE CIGÜEÑAL Y R.P.M.  
CRANKSHAFT SENSOR & R.P.M.  
SENSORE ALBERO MOTORE E R.P.M.**

Ref.	R.O. OEM
REC21426987	21426987 20513343



**MOTORES / ENGINES / MOTORI**

D1-13B, 20B, 30B,  
D2-40F, 55B, 55C, 55D, 55E, 55F,  
75B, 75C, 75F  
D4-180I-B, I-C, I-D, I-E, I-F,  
D4-210A-A, I-A, I-B  
D4-225A-B, I-B, A-C, A-D, I-C, I-D,  
A-E, I-E, A-F, I-F  
D4-260A-A, A-B, A-C, A-D, D-B, D-C,  
D-D, I-A, I-B, I-C, I-D, A-E, D-E, I-E,  
A-F, D-F, DI-F  
D6-280A-A, A-B, A-C, A-D, A-E, I-A,  
I-B, I-C, I-D, I-E  
D4-300A-A, A-C, A-D, D-A, D-C,  
I-A, I-C, I-D, A-E, D-E, D-D, I-E, A-F,  
D-F, I-F  
D6-300A-F, D-F (MC), I-F  
D6-310I-A, A-A, A-B, A-C, A-D, D-B,  
D-C, D-D, I-B, I-C, I-D, A-E, D-E, I-E  
D6-330A-B, A-C, A-D, D-B, D-C,  
D-D, I-B, I-C, I-D, A-E, D-E, I-E, A-F,  
D-F, I-F  
D6-350A-A, A-B  
D6-370A-B, A-C, A-D, D-B, D-C, D-D,  
I-A, I-B, I-C, I-D, A-E, D-E, I-E, A-F,  
D-F, I-F  
D6-400A-E, A-F  
D6-435D-A, D-D, D-C, D-E, I-A, I-C,  
I-D, I-E, D-F, I-SC-F, I-TC-F, I-WJ-F  
D9A2A D9-425, D9-500, D9-500  
(R4), D9-500 (R5), D9-575



**SENSOR ÁRBOL DE LEVAS  
CAMSHAFT SENSOR  
SENSORE ALBERO A CAMME**

Ref.	R.O. OEM
REC3863130	3863130



**MOTORES / ENGINES / MOTORI**

3.0, 4.3, 5.0, 5.7L  
G1, GXI  
V6 & V8  
Para distribuidor de tapa plana  
For flat cap distributor  
Per distributore a copercchio piatto

Ref.	R.O. OEM
REC3859082	3859082 3861323



**MOTORES / ENGINES / MOTORI**

8.1Gi-A, B, BF, C, CF, D, DF,  
8.1LGSi-A,  
8.1GXi-A, AF, B, BF, C,  
8.1Gi-E, EF,  
8.1GXi-D, DF,  
8.1OSi-A, AF,  
8.1Gi-E,  
8.1GXil-D (2001-07)

Ref.	R.O. OEM
REC8631533	8631533



**MOTORES / ENGINES / MOTORI**

D3-110 --> D3-190 (I-A, A-A)



Ref.	R.O. OEM
REC8658726	8658726



**MOTORES / ENGINES / MOTORI**  
D3-110 --> D3-220



**SENSOR TPS  
TPS SENSOR  
SENSORE TPS**

Ref.	R.O. OEM
REC805226A1	3855184



**MOTORES / ENGINES / MOTORI**  
V6, 305, 350, 454, 502, EFC



Ref.	R.O. OEM
REC803148	3855296



**MOTORES / ENGINES / MOTORI**

7.4 GSI  
8.2 GSI  
DPX 385, 415  
BY/EF  
WT/HU  
LK/NC



Ref.	R.O. OEM
REC853678T	3857487



**MOTORES / ENGINES / MOTORI**

4.3, 5.0, 5.7, 8.1, 8.2L



**SENSOR DE PICADO  
KNOCK SENSOR  
SENSORE DI ANTICIPO**

Ref.	R.O. OEM
REC8M0077616	3854512

**MOTORES / ENGINES / MOTORI**

7.4 GL, GI, GS  
8.2 (1989-01) GS, GS



Ref.	R.O. OEM
------	----------

REC3854905 3854905

**MOTORES / ENGINES / MOTORI**

4.3L (1994-02),  
5.0L Gxi-A (2001-02),  
5.7L GiL-A (2001), Gi-A, GXI-A, GXI-B, GiL-A,  
GSil-A, GXil-A, GXil-B (2000-03),  
5.7GLPNCs, GIPNCACE, GIPNCsCE,  
GIPNCMCE, GIPNCBCE, GIINCCCE,  
GIINCSCE (1995-96)



Ref.	R.O. OEM
------	----------

REC22024631 3850357  
22024631

**MOTORES / ENGINES / MOTORI**

4.3, 5.0, 5.7L  
Gi / GXI (Modelos modernos / new  
models / modelli nuovi)



**VACUÓMETRO. MAP  
MAP SENSOR. MAP  
VACUOMETRO. MAP**



Ref.	R.O. OEM
------	----------

REC3850396 3850396

**MOTORES / ENGINES / MOTORI**

4.3, 5.0, 5.7, 7.4L (1994-07)  
Gi, GXI



**MAT / MAP**

Ref.	R.O. OEM
------	----------

REC8M0087834 3859020  
3858987

**MOTORES / ENGINES / MOTORI**

V6 Gi, GXI  
V8 Gi, GXI



Ref.	R.O. OEM
------	----------

REC31216308 31216308

**MOTORES / ENGINES / MOTORI**

D3-110, 220



**BOMBILLA RELOJ INSTRUMENTOS  
BULB WATCH INSTRUMENTS  
LAMPADINA OROLOGIO STRUMENTI**

Ref.	R.O. OEM
------	----------

REC863946 863946

12V 1.2W

Rojo. Compatible con casi todos los instrumentos.  
Red. Compatible with almost all instruments.  
Rosso. Compatibile con quasi tutti gli strumenti.



**COMPRESOR  
COMPRESSOR  
COMPRESSORE**

COMPRESSOR OIL  
RM85108974



**MÓDULO ELECTRÓNICO  
ELECTRONIC MODULE  
MODULO ELETTRONICO**

MOTOR ENGINE MOTORE	REF	R.O. OEM
KAD42A - KAMD42A (-2204202416)	RM860993	860993
		860433
		860434
		860435
KAD42A - KAMD42A (2204202417+)	RM881797	881797
		872616
KAD32, PA		

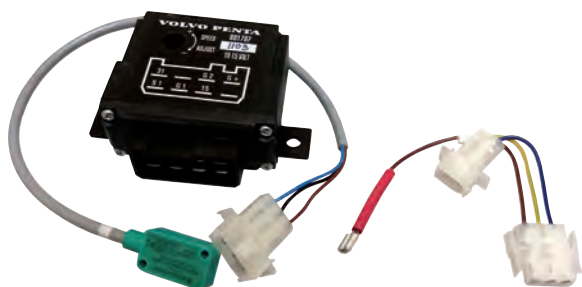

**EMBRAGUE  
CLUTCH  
FRIZIONE**

MOTOR ENGINE MOTORE	REF	R.O. OEM
D4-260		
KAD32P-A		3581724
KAD43P-A		3581062
KAD42	RM3581724	860786
KAD44		
KAD300		



# COMPONENTES DEL DISTRIBUIDOR DISTRIBUTOR COMPONENTS COMPONENTI DI SPINTEROGENO

## 4 CYL

### TAPA CAP CALOTTA

Ref.	R.O. OEM
REC243797	243797
REC841263	841263
REC870690	870690



REC243797



REC841263



REC870690

### PLATINO POINT PUNTINE

Ref.	R.O. OEM
REC243799	243799
REC1306169	1306169



REC243799



REC1306169

### ROTOR ROTOR ROTORE

Ref.	R.O. OEM
REC243903	243903



### CONDENSADOR CONDENSER CONDENSATORE

Ref.	R.O. OEM
REC841262	841262 241710
REC243653	243653



REC841262



REC243653

### KIT

Ref.	R.O. OEM
REC9-29307	



REC243903



+ REC243799



+ REC841262

MOTOR ENGINE MOTORE	TAPA CAP CALOTTA	ROTOR ROTOR ROTORE	PLATINO POINT PUNTINE	CONDENSADOR CONDENSER CONDENSATORE
AQ115, 120B, 130, 140A	REC243797	REC243903	REC243799	REC841262
AQ120B AQ125A, B AQ131A, B, C, D AQ140A AQ145A, B AQ151A, B, C AQ230A AQ250A	REC841263	REC243903	REC243799	REC243653
AQ115A, B AQ120 AQ130A, B, C, D	REC870690	REC243903	REC1306169	REC841262

## 6 CYL AQ170

### TAPA CAP CALOTTA

Ref.	R.O. OEM
REC241669	241669



### MOTORES / ENGINES / MOTORI

AQ165, 170  
Delco Bosch Ø 73mm

Ref.	R.O. OEM
REC243658	243658



### MOTORES / ENGINES / MOTORI

AQ170B, C  
Delco Bosch Ø 90mm

### ROTOR ROTOR ROTORE

Ref.	R.O. OEM
REC238258	238258



### MOTORES / ENGINES / MOTORI

AQ170 Bosch 6 cil.

### PLATINO POINT PUNTINE

Ref.	R.O. OEM
RM243801	243801



### MOTORES / ENGINES / MOTORI

AQ170  
(Versión moderna / Late models / Versione moderna)

Ref.	R.O. OEM
REC241652	241652



### MOTORES / ENGINES / MOTORI

AQ170  
(Versión antigua / Old models / Versione vecchia)

**PRESTOLITE**

**TAPA  
CAP  
CALOTTA**

Ref.	R.O. OEM
REC392-9086T	841926
REC392-9766	3853815
REC835702	835702



REC392-9086T



REC392-9766



REC835702

**ROTOR  
ROTOR  
ROTORE**

Ref.	R.O. OEM
REC3853801	3853801
REC834975	834975



REC3853801



REC834975

**PLATINO  
POINT  
PUNTINE**

Ref.	R.O. OEM
REC8M6001219	835705



**CONDENSADOR  
CONDENSER  
CONDENSATORE**

Ref.	R.O. OEM
REC8M6001249	835704



**KITS**

Ref.	R.O. OEM
REC392-6324Q1	



REC3853801



REC8M6001219



REC8M6001249

Ref.	R.O. OEM
REC392-6325Q1	



REC834975



REC8M6001219



REC8M6001249

MOTOR ENGINE MOTORE	TAPA CAP CALOTTA	ROTOR ROTOR ROTORE	PLATINO POINT PUNTINA	CONDENSADOR CONDENSER CONDENSATORE
V6 PRESTOLITE AQ175A AQ205A AQ430A, B AQ431A, B	REC392-9086T	REC3853801	REC8M6001219	REC8M6001249
V8 PRESTOLITE Atornillado screw-down Avvitato AQ211A AQ231A, B AQ271A, B AQ311A AQ500A, B AQ501A, B	REC392-9766	REC3853801	REC8M6001219	REC8M6001249
V8 PRESTOLITE Clip Clip-on Clip 190A, 200D, 225D, 240A, 255B, 260A, 280A, 290A	REC835702	REC834975	REC8M6001219	REC8M6001249

**MALLORY**

**TAPA PLANA / FLAT CAP / CALOTTA PIANA  
AQ210A, 200B, 225A, B, C, 255A, B**

**TAPA  
CAP  
CALOTTA**

Ref.	R.O. OEM
REC12532	841244



**ROTOR  
ROTOR  
ROTORE**

Ref.	R.O. OEM
REC841243	841243



**PLATINO  
POINT  
PUNTINE**

Ref.	R.O. OEM
REC391-5090	835304



**CONDENSADOR  
CONDENSER  
CONDENSATORE**

Ref.	R.O. OEM
REC8M6001217	835308



**MALLORY**  
TAPA ESTANDAR / STANDARD CAP /  
CALOTTA STANDARD

**TAPA  
CAP  
CALOTTA**

Ref.	R.O. OEM
REC982209	508932



**ROTOR  
ROTOR  
ROTORE**

Ref.	R.O. OEM
REC89825302	508935



**PLATINO  
POINT  
PUNTINE**

Ref.	R.O. OEM
REC391-5090	835304



**CONDENSADOR  
CONDENSER  
CONDENSATORE**

Ref.	R.O. OEM
REC8M6001217	835308



**KIT**

Ref.	R.O. OEM
REC391-5090Q1	



REC89825302 + REC391-5090 + REC8M6001217

**4-CYL DELCO EST  
GM 3.0L / 181CI / 4-CYL**

**TAPA  
CAP  
CALOTTA**

Ref.	R.O. OEM
REC3854260	3854260



**ROTOR  
ROTOR  
ROTORE**

Ref.	R.O. OEM
REC3854261	3854261



**V6 DELCO EST  
GM 4.3L / 262CI / V6**

**TAPA  
CAP  
CALOTTA**

Ref.	R.O. OEM
REC3854331	3854331



**ROTOR  
ROTOR  
ROTORE**

Ref.	R.O. OEM
REC3854311	3854311



**V6 GXI**

**TAPA  
CAP  
CALOTTA**

Ref.	R.O. OEM
REC898253T23	3859019



**ROTOR  
ROTOR  
ROTORE**

Ref.	R.O. OEM
REC898253013	898253013 3858977

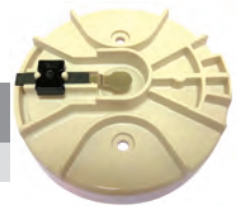

**V8 DELCO EST  
VOLVO GM V8**

**TAPA  
CAP  
CALOTTA**

Ref.	R.O. OEM
REC3854548	3854548



**ROTOR  
ROTOR  
ROTORE**

Ref.	R.O. OEM
REC3854549	3862014



**V8 GXI**

**TAPA  
CAP  
CALOTTA**



Ref.	R.O. OEM
REC898253T22	3858975

**ROTOR  
ROTOR  
ROTORE**

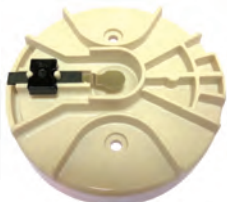

Ref.	R.O. OEM
REC898253013	898253013 3858977

**V8 FORD  
FORD 5.0L / 302CI EFI & 5.8L /  
351CI EFI  
(1993-96)**

**TAPA  
CAP  
CALOTTA**



Ref.	R.O. OEM
REC3854217	3854217

**ROTOR  
ROTOR  
ROTORE**



Ref.	R.O. OEM
REC3854218	3854218

**DISTRIBUIDORES  
DISTRIBUTORS  
SPINTEROGENI**

Ref.	R.O. OEM
REC807964A1	

**MOTORES / ENGINES / MOTORI**  
V6 (modelo antiguo HEI / late model HEI /  
modello vecchio HEI)  
4.3 GL, GXI-A



Ref.	R.O. OEM
REC805222A1	3857449

**MOTORES / ENGINES / MOTORI**  
V8 (modelo antiguo HEI / late model HEI /  
modello vecchio HEI)  
5.0, 5.7 GL, GS, GXI-A  
7.4GII, GS

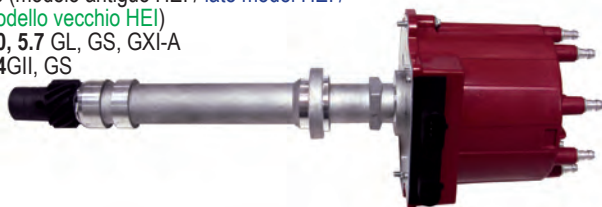

Ref.	R.O. OEM
REC40005334	40005334

**MOTORES / ENGINES / MOTORI**  
V6 GXI

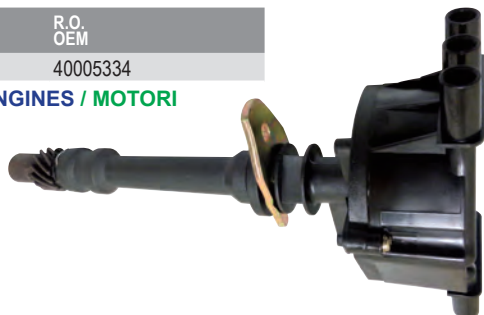

Ref.	R.O. OEM
REC21622232	21622232

**MOTORES / ENGINES / MOTORI**  
V8 GXI, GI

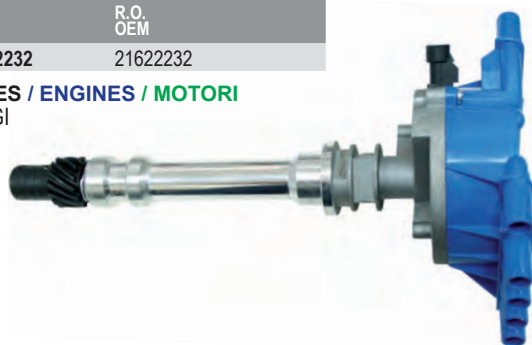

Ref.	R.O. OEM
REC817377	

**MOTORES / ENGINES / MOTORI**  
3.0 GL, GS Delco





**DISTRIBUIDOR DELCO VOYAGER®**  
**DISTRIBUTOR DELCO VOYAGER®**  
**SPINTEROGENO DELCO VOYAGER®**  
 (4, 6, 8 CYL GM)

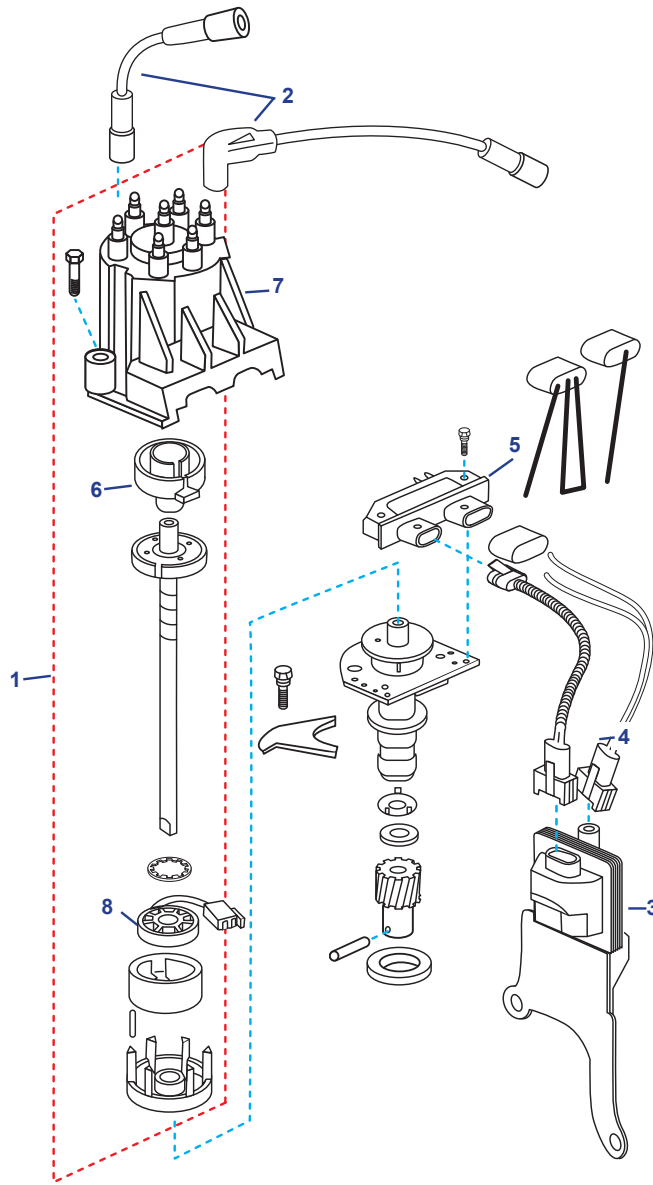

Nº	Ref.	R.O. OEM	Descripción	Description	Descrizione
1	REC817377		DISTRIBUIDOR 4 CYL	DISTRIBUTOR 4 CYL	DISTRIBUTORE 4 CYL
1	REC807964A1		DISTRIBUIDOR 6 CYL	DISTRIBUTOR 6 CYL	DISTRIBUTORE 6 CYL
1	REC805222A1		DISTRIBUIDOR 8 CYL	DISTRIBUTOR 8 CYL	DISTRIBUTORE 8 CYL
2	REC15-405	3888324	KIT CABLE ARRANQUE: 3.0L (4 CYL)	IGNITION WIRE SET: 3.0L	KIT CAVI INIEZIONE: 3.0L
2	REC15-601	3888325	KIT CABLE ARRANQUE: V6	IGNITION WIRE SET: V6	KIT CAVI INIEZIONE: V6
2	REC15-804	3888326	KIT CABLE ARRANQUE: V8	IGNITION WIRE SET: V8	KIT CAVI INIEZIONE: V8
3	REC3854002	3854002	BOBINA ARRANQUE	COIL: IGNITION	BOBINA INIEZIONE
4	REC84-817376T01	3854084	CABLE: DISTRIBUIDOR - BOBINA	WIRE LEAD: DIST - COIL	CAVO: DISTRIBUZIONE - BOBINA
5	REC3854003	3854003	MÓDULO DISTRIBUIDOR	MODULE: DISTRIBUTOR	MODULO DISTRIBUZIONE
6	REC3854261	3854261	ROTOR 4 CYL	ROTOR 4 CYL	ROTORE 4 CYL
6	REC3854311	3854311	ROTOR V6	ROTOR V6	ROTORE V6
6	REC3854549	3854549	ROTOR V8	ROTOR: V8	ROTORE: V8
7	REC3854260	3854260	TAPA 4 CYL	CAP 4 CYL	COPERCHIO 4 CYL
7	REC3854311	3854331	TAPA 6 CYL	CAP 6 CYL	COPERCHIO 6 CYL
7	REC3854548	3854548	TAPA 8 CYL	CAP 8 CYL	COPERCHIO 8 CYL
8	REC3854001	3854001	MÓDULO IMPULSOS	MODULE	MODULO

**DISTRIBUIDOR MPI V6 & V8**  
**DISTRIBUTOR MPI V6 & V8**  
**SPINTEROGENO MPI V6 & V8**  
**(GM)**

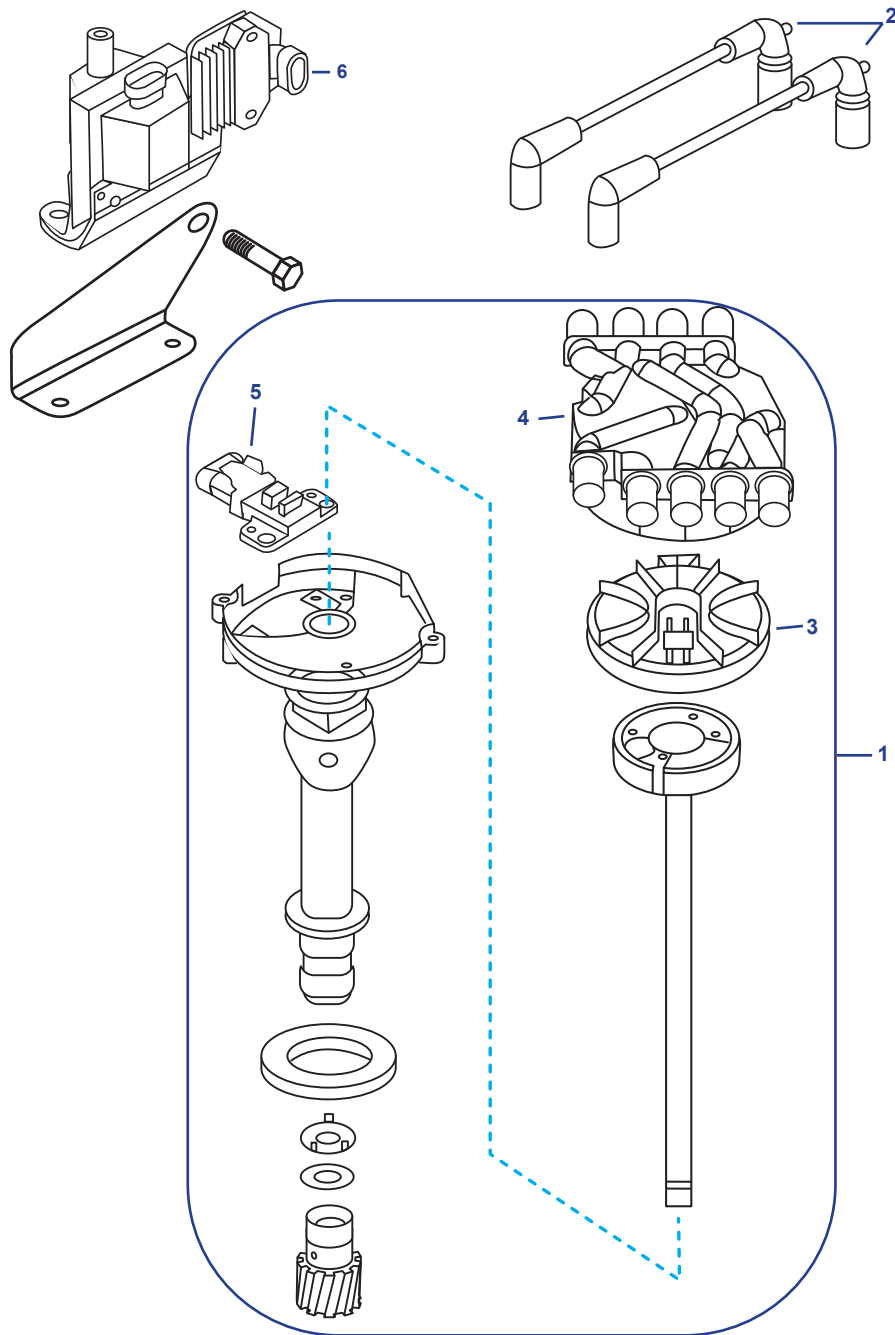

Nº	Ref.	R.O. OEM	Descripción	Description	Descrizione
1	REC40005334	40005334	DISTRIBUIDOR V6	DISTRIBUTOR V6	DISTRIBUTORE V6
1	REC21622232	21622232	DISTRIBUIDOR V8	DISTRIBUTOR V8	DISTRIBUTORE V8
2	REC15-606	3888327	KIT CABLES V6	WIRES KIT V6	KIT CAVI V6
2	REC15-815	3888328	KIT CABLES V8 (5.0L, 5.7L)	WIRES KIT V8 (5.0L, 5.7L)	KIT CAVI V8 (5.0L, 5.7L)
3	REC898253013	3858977	ROTOR	ROTOR	ROTORE
4	REC898253T23	3859019	TAPA V6	CAP V6	COPERCHIO V6
4	REC898253T22	3858975	TAPA V8	CAP V8	COPERCHIO V8
5	REC3863130	3863130	SENSOR POSICIÓN ÁRBOL DE LEVAS	POSITION SENDER CRANKSHAFT	SENSORE POSIZIONE ALBERO A CAMME
6	REC3861985	3861985	BOBINA ENCENDIDO	IGNITION COIL	BOBINA INIEZIONE

# KITS DE CONVERSIÓN ELECTRÓNICO ELECTRONIC CONVERSION KITS KIT CONVERSIONE ELTTRONICO

- Sostituyen condensadores y contactos por componentes electrónicos.
- Usa bobina, tapa y rotor estandard.
- De fácil instalación, una pieza y dos cables.
- Precisión entre 1/4" calibrado de 0 a 8000 rpm.
- To substitute condensers for electronic devices
- Uses standard.coil, cap & rotor
- Easy installation; one piece, two cables.
- Precisely calibrated between 1/4" from 0 to 8000
- Sostituiscce condensatori e contatti per componenti elettronici.
- Utilizza bobina, calotta e rotore standard.
- Facile installazione, un pz e due cavi.
- Precisione 1/4" calibrato da 0 a 8000.

Ref. R.O. OEM  
REC26900

**MOTORES / ENGINES / MOTORI**  
GM 4 cil.



Ref. R.O. OEM  
REC26901

Para la mayoría de distribuidores de 6 cilindros Delco.  
For most Delco 6 cyl. distributors.  
Per la maggior parte degli spinterogeni da 6 cil Delco.



Ref. R.O. OEM  
REC26902

Para la mayoría de distribuidores Prestolite V8 con tornillo en la tapa.  
For most Prestolite V8 distributors with screw on cap  
Per la maggior parte degli spinterogeni Prestolite V8 (con vite nella calotta).



Ref. R.O. OEM  
REC26903

Para distribuidores Prestolite V8 con clip en la tapa.  
For most Prestolite V8 distributors with clip on cap  
Per spinterogeni Prestolite V8 con clip nella calotta



Ref. R.O. OEM  
REC26904

Para la mayoría de distribuidores de 8 cilindros Mallory YL o YD con rotación reloj y contrareloj.  
For most Mallory V8 distributors.  
Per la maggior parte degli spinterogeni da 8 cil Mallory YL o YD con rotazione std e controrotante.



Ref. R.O. OEM  
REC18-5295

Para la mayoría de distribuidores de 4 cilindros Prestolite.  
For most Prestolite 4 cil.  
Per al maggior parte degli spinterogeni Prestolite V (con vite nella calotta).



Ref. R.O. OEM  
REC3854077 3854077

**MOTORES / ENGINES / MOTORI**  
V8 GM



# MÓDULO ENCENDIDO IGNITION MODULE MODULO ACCENSIONE

Ref. R.O. OEM  
REC3854001 3854001

**MOTORES / ENGINES / MOTORI**  
4L, V6 & V8 DELCO

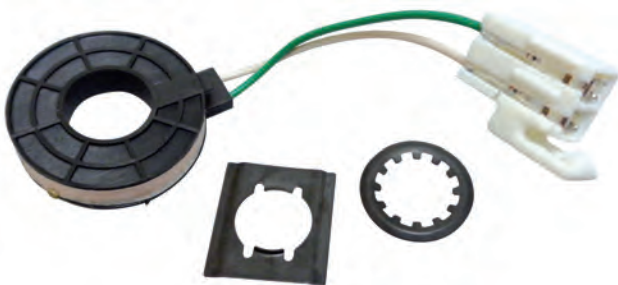

Ref. R.O. OEM  
REC3854003 3854003

**MOTORES / ENGINES / MOTORI**  
4L, V6 & V8 DELCO



Ref. R.O. OEM  
REC3858984 3858984

**MOTORES / ENGINES / MOTORI**  
V6 & V8 Vortec



# BOBINAS ENCENDIDO IGNITION COILS BOBINE ACCENSIONE

Ref.	R.O. OEM
REC300-00879	3852217

No usa resistencia externa.  
Utilizar con encendido Prestolite.  
Use without external resistor & Prestolite  
ignition  
Non utilizza resistenza esterna. Utilizzare con  
spinterogeno Prestolite



Ref.	R.O. OEM
REC1463-9382	835998

Resistencia externa.  
Utilizar con encendido convencional.  
External resistor. Use with conventional  
ignition  
Resistenza esterna. Utilizzare con accensione  
convvenzionale



Ref.	R.O. OEM
REC3287677	3287677

**MOTORES / ENGINES / MOTORI**  
AQ171A, C  
AQ251A, (1988-92)



Ref.	R.O. OEM
REC3861267	3861267

**MOTORES / ENGINES / MOTORI**  
8.1Gi-A, B, BF, C, CF, D, DF  
8.1GSi-A  
8.1GXi-A, AF, B, BF, C  
DPX375, 420



Ref.	R.O. OEM
REC3854002	3854002

**MOTORES / ENGINES / MOTORI**  
4L, V6 & V8 DELCO



Ref.	R.O. OEM
REC3854161	3854161

**MOTORES / ENGINES / MOTORI**  
FORD 5.0L / 302Ci EFI  
5.8L / 351Ci EFI (1993-96)



Ref.	R.O. OEM
REC3859078	3859078

**MOTORES / ENGINES / MOTORI**  
8.1L



Ref.	R.O. OEM
REC3861985	3861985

**MOTORES / ENGINES / MOTORI**  
4.3L GXI  
5.0L GXI  
5.7L GXI



Ref.	R.O. OEM
REC21436799	21436799

**MOTORES / ENGINES / MOTORI**  
Delco HVS  
V6, V8 (Versión moderna / Late models / Versione  
moderna)  
GX1

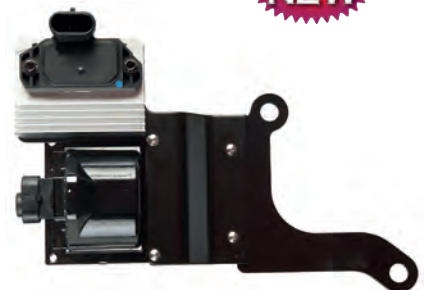

**NEW**

# BUJÍAS SPARK CANDELE



Modelo Model Modello	Ref. CHAMPION	Modelo Model Modello	Ref. CHAMPION	Modelo Model Modello	Ref. CHAMPION
<b>SERIES AQ</b>		115A, B 165A	CHARL82YC	5.0L Fi, 5.0L GL Gen 1+	CHARS12YC
120 (B21)	CHARN7YC	140	CHARN9YC	5.0L Gi GEN 1+	CHARS12YC
125A, B 145	CHARN7YC	145, A	CHARN7YC	5.7L Gi, GL, GLi, GS	CHARV15YC4
130, A, B, C, D	CHARL82YC	225, A, B, C 231A	CHARV15YC4	5.7L GS Gen 1+, GSi Gen 1+	CHARS12YC
131, A, B, C, D	CHARN7YC	260, A, B, C 261	CHARV15YC4	5.8L FL	CHARV15YC4
140, A 145A, B	CHARN7YC	<b>SERIES OCEAN</b>		5.8L FSi	CHARS9YC
151A, B, C	CHARN7YC	GM V-6, 2002 4.3L OSi-XDP	CHARS12YC	7.4L Gi, GL	CHARV15YC4
165A	CHARL82YC	GM V-8, 2002 5.0L OSi-XDP	CHARS12YC	7.4L Gi L29	CHARS12YC
170, A, B, C	CHARL82YC	GM V-8, 2002 5.7L OSi-XDP	CHARS12YC	7.4L GSi, 8.2L GSi	CHARV15YC4
171A, C	CHARN9YC	GM V-8, 2002 5.7L OSXi-XDP	CHARS12YC	<b>SERIES ALTA CILINDRADA HIGH HORSEPOWER SERIES SERIE ALTO CILINDRO</b>	
175, A	CHARV15YC4	<b>PJX Water Jet</b>		8.2L DPX 500, DPX 525	CHAV63C
180	CHARJ12YC	4.3L Gi, GS	CHARS12YC	8.2L DPX 600	CHAV63C
190, A FORD	CHARV15YC4	<b>SERIES SX Cobra</b>		<b>SERIES M</b>	
200, A, B, C, D, F 205A	CHARV15YC4	3.0L GS	CHARS12YC	MB36A, B	CHARJ12YC
210A (177315+)	CHARV9YC	4.3L GIPNCA	CHARV15YC4	MB250S	CHAP8Y
211A, DP, 231D, P 271D, P	CHARV15YC4	4.3L GIPNCS	CHARS12YC	PZ-200	CHARV15YC4
255, A, C	CHARV15YC4	5.0L FL	CHARV15YC4	AQ60F	
255D 305 CID 225E, F	CHARV15YC4	5.0L Fi, Gi Gen 1+, GL Gen 1+	CHARS12YC	BB30F	CHAL90C
230A, B 250A, B	CHARN7YC	5.7L Gi, GL, GLi, GS	CHARV15YC4	MB18F	
231A, B 240A FORD 255B 280A	CHARV15YC4	5.7L GS Gen 1+, GSi Gen 1+	CHARS12YC	<b>SERIES INTRABORDA INBOARD SERIES SERIE ENTROBORDO</b>	
260A, B 271A, B, C, D 290, A, B	CHARV15YC4	5.8L FL	CHARV15YC4	2002, 5.7L Gi	CHARV15YC4
311, A, B 430, 531, 500A, 501A	CHARV15YC4	5.8L Fi, FSi	CHARS9YC	2002, 5, 5.7L GSi, GXi	CHARS12YC
570A, 571A, 572, 740A	CHARV15YC4	7.4L GL, Gi	CHARV15YC4	5.8L FL/HS1	CHARV15YC4
<b>SERIES B/BB</b>		7.4L Gi L29	CHARS12YC	5.8L FSi, HS1	CHARS9YC
18A, C 30B	CHARL82C	<b>SERIES C</b>		7.4L GL, Gi/HS1	CHARV15YC4
100, A	CHARL86C	C5, 10, 23	CHARD16	7.4L Gi L29 STANDARD	CHARS12YC
		<b>SERIES DPX</b>		7.4L Gi L29 PLATINUM	CHARS12PYP
		7.4L DPX 385	CHARV15YC4	2002, 8.1L Gi/GSi	CHARS15LYC
		8.2L DPX 415	CHARV15YC4	2002, 8.2L GL/HS1	CHARV15YC4
		<b>SERIES DUOPROP</b>			
		4.3L GIPNCA	CHARV15YC4		
		4.3L, GIPNCS	CHARS12YC		
		5.0L FL	CHARV15YC4		

# BUJÍAS SPARK CANDELE



Modelo Model Modello	Ref. STANDARD	Ref. IRIDIUM	Modelo Model Modello	Ref. STANDARD	Ref. IRIDIUM	Modelo Model Modello	Ref. STANDARD	Ref. IRIDIUM
<b>SERIES AQ</b>			211/DP 211A	NGKYR5	NGKYR5IX	430, 500A, 501A, 531, 570A	NGKBR6FS	NGKBR6FIX
145A, B	NGKBP7ES	NGKBPR7EIX	225B, A, B, C, D	NGKUR6	NGKUR6IX	571A, 572, 740A	NGKBR6FS	NGKBR6FIX
130, A, B, C, D	NGKBP7HS	NGKBPR7EIX	225E, F	NGKYR5	NGKYR5IX	<b>SERIES DPX</b>		
131, A, B, C, D, 140A	NGKBP7ES	NGKBPR7EIX	230A, B 250A, B	NGKBP6ES	NGKBP6EIX	5.7L DPX 375	NGKTR55	NGKTR55IX
150, A, B	NGKXR5		231/DP 231A, B	NGKYR5	NGKYR5IX	7.4L DPX 385 GSi EFI	NGKBR6FS	NGKBR6FIX
151A, B, C	NGKBP7ES	NGKBPR7EIX	240A 255B	NGKUR6	NGKUR6IX	8.1L DPX 420	NGKTR55	NGKTR55IX
165A 170, A, B, C	NGKBP7HS	NGKBPR7EIX	260, A, B	NGKBR6FS	NGKBR6FIX	8.2L DPX 415 GSi EFI	NGKBR6FS	NGKBR6FIX
171A, C	NGKBP6ES	NGKBPR7EIX	271/DP	NGKYR5	NGKYR5IX	<b>SERIES DUOPROP</b>		
175, A	NGKYR5	NGKYR5IX	271A, B, C, D	NGKBR6FS	NGKBR6FIX	4.3L Gi EFI (.460 Rch.)	NGKBP6FS	NGKUR6IX
180	NGKXR5	NGKYR5IX	280A	NGKUR6	NGKUR6IX	4.3L Gi EFI (.708 Rch.)	NGKBP6EFS	NGKTR6IX
190	NGKYR5	NGKYR5IX	290A, B 311A, B	NGKBR6FS	NGKBR6FIX			
200, A, B, C, D, F	NGKUR5	NGKUR6IX						
210A (177315+)	NGKUR6	NGKUR6IX						

Modelo Model Modello	Ref. STANDARD	Ref. IRIDIUM
4.3L GL 2 bbl, GS 4 bbl	NGKBPR6EFS	NGKTR6IX
5.0L Fi EFI	NGKTR5	NGKTR5IX
5.0L FL 2bbl	NGKUR4	NGKUR4IX
5.0L Gi, GL Gen 1+	NGKBPR6EFS	NGKTR6IX
5.7L Gi EFI	NGKBPR6FS	NGKUR6IX
5.7L GL 2 bbl	NGKBR6FS	NGKBR6FIX
5.7L GLi EFI	NGKBPR6FS	NGKTR6IX
5.7L GS 4 bbl	NGKBR6FS	NGKBR6FIX
5.7L GS, GSi Gen 1+	NGKBPR6EFS	NGKTR6IX
5.7L GXi	NGKTR55	NGKTR55IX
5.8L FL 4 bbl	NGKUR4	NGKUR4IX
5.7L FSi EFI HO	NGKBPR6EFS	NGKTR6IX
7.4L Gi EFI, Gi L29	NGKBPR6EFS	NGKTR6IX
7.4L GL 4 bbl	NGKBR6FS	NGKBR6FIX
7.4L GSi EFI	NGKBR6FS	NGKBR6FIX
8.1L GXi	NGKTR55	NGKTR55IX
8.2L GSi EFI	NGKBR6FS	NGKBR6FIX
PJX Water Jet		
4.3L Gi EFI	NGKBPR6EFS	NGKTR6IX
4.3L GS 4 bbl	NGKBPR6EFS	NGKTR6IX

Modelo Model Modello	Ref. STANDARD	Ref. IRIDIUM
SX Cobra Grande		
3.0L GS 2 bbl	NGKBPR6EFS	NGKTR6IX
4.3L Gi EFI (.460 Rch.)	NGKBPR6FS	NGKUR6IX
4.3L Gi EFI (.708 Rch.)	NGKBPR6EFS	NGKTR6IX
4.3L GL 2 bbl	NGKBPR6EFS	NGKTR6IX
4.3L GS 4 bbl	NGKBPR6EFS	NGKTR6IX
5.0L Fi EFI	NGKTR5	NGKTR5IX
5.0L FL 2 bbl	NGKUR4	NGKUR4IX
5.0L Gi Gen 1+	NGKBPR6EFS	NGKTR6IX
5.0L GL Gen 1+	NGKBPR6EFS	NGKTR6IX
5.7L Gi EFI	NGKBR6FS	NGKUR6IX
5.7L GL 2 bbl	NGKBR6FS	NGKBR6FIX
5.7L GLi EFI	NGKBPR6FS	NGKUR6IX
5.7L GS 4 bbl	NGKBR6FS	NGKBR6FIX
5.7L GS Gen 1+	NGKBPR6EFS	NGKTR6IX
5.7L GSi Gen 1+	NGKBPR6EFS	NGKTR6IX
5.7L GXi	NGKTR55	NGKTR55IX
5.8L FL 4 bbl	NGKUR4	NGKUR4IX
5.8L FSi EFI HO	NGKBPR6EFS	NGKTR6IX
7.4L Gi EFI	NGKBPR6FS	NGKUR6IX

Modelo Model Modello	Ref. STANDARD	Ref. IRIDIUM
7.4L Gi L29	NGKBPR6EFS	NGKTR6IX
7.4L GL 4 bbl	NGKBR6FS	NGKBR6FIX
SERIES OCEAN		
4.3L OSi-XPD	NGKTR5	NGKTR5IX
5.0L OSi-XPD	NGKTR5	NGKTR5IX
5.7L OSi-XPD	NGKTR5	NGKTR5IX
5.7L OOXi-XPD	NGKTR5	NGKTR5IX

## JUEGOS DE CABLE PARA BUJÍAS DE ALTO RENDIMIENTO HD SPARK PLUG WIRE SET KIT CAVI CANDELE ALTE PRESTAZIONI

- Núcleo del cable de Kevlar de 8 mm antimagnético
- Funda de silicona amarilla
- Terminales bujías con muelle de acero inox
- Terminal del Distribuidor de Cobre
- Terminales Bobina
- Silicona resistente a altas temperaturas
- Garantía de 5 años

- Antimagnetic Kevlar core
- Yellow silicone boot & jacket
- SS snaplock
- Brass distributor terminal
- Coil terminals
- High resistant silicone
- 5 year warranty

- Nucleo dei cavi in Kevlar da 8 mm antimagnetico
- Fodera in silicone gialla
- Terminali candele con molle di acciaio inox.
- Terminale lato spinteorgeno in rame
- Terminali Bobina
- Silicone resistente alle alte temperature
- Garanzia 5 anni

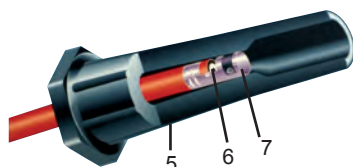
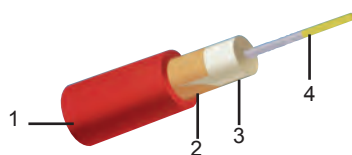

Nº	Descripción	Description	Descrizione
1	Camisa de silicona de 8 mm.	8 mm silicone jacket	Guaina in silicone da 8 mm
2	Latex resistente altas temperaturas	heat resistant latex	Latex resistente alle alte emperature
3	Acero inox	Stainless Steel	Acciaio inox
4	Núcleo de Kevlar	Kevlar core	Nucleo de Kvlar
5	Capuchón de silicona	silicone jacket	Cappucio in silicone
6	Trenzado fibra	Fiberglass braiding	Fibra di vetro
7	Terminal de acero inox	Stainless Steel terminal	Terminale in acciaio inox

Ref	R.O. OEM	MODELO MODEL MOELLO	ARRANQUE CONVENCIONAL IGNITION CONVENTIONAL AVVIAMENTO CONVENZIONALE	ARRANQUE ELECTRONICO IGNITION ELECTRONIC AVVIAMENTO ELETTRONICO	CYL
REC15-404	875571	4L. Base Volvo	✓		4
REC15-604	3857166	V6 Base GM	✓		6
REC15-801	3857166	V8 Base GM	✓		8
REC15-806	3857166	V8 Base GM (Tapa delco plana / Flat Cap / Calotta Delco piatta)	✓		8
REC15-405	3888324	4L. Base GM		✓	4
REC15-601	3888325	V6 Base GM		✓	6
REC15-606	3888327	V6 Base GM-MPI		✓	6
REC15-804	3888326	V8 Base GM		✓	8
REC15-815	3888328	V8 5.0/5.7 GM-MPI		✓	8
REC15-808	3861295	V8 8.1L		✓	8

# MOTORES DE ARRANQUE STARTERS MOTORINO D'AVVIAMENTO

Ref.	R.O. OEM	kw	V	DIENTES TOOTH DENTI
REC21302969	21302969	1.4	12	9

**MOTORES / ENGINES / MOTORI**  
2030  
D1-30  
D2-40



Ref.	R.O. OEM	kw	V	DIENTES TOOTH DENTI
REC21323043	21323043	1.4	12	9
	3583555			
	3801351			
	3803929			

**MOTORES / ENGINES / MOTORI**  
D2-50, 55, 60, 75



Ref.	R.O. OEM	kw	V	DIENTES TOOTH DENTI
REC3827444	874385	6	24	12
	3827444			

**MOTORES / ENGINES / MOTORI**  
TAD1240, 1241, 1242, 1250, 1251, 1252  
D12



Ref.	R.O. OEM	kw	V	DIENTES TOOTH DENTI	
PH140-0023	872241	1.1	12	9	HITACHI
	859593				

**MOTORES / ENGINES / MOTORI**  
AQ120, 125, 145, 131, 151, 171, 251A,  
2001, 2002, 2003



Ref.	R.O. OEM	kw	V	DIENTES TOOTH DENTI	
PH150-0007-OE	3581774	3.1	12	11	VALEO
	188486				
PH150-0007	8599252				

**MOTORES / ENGINES / MOTORI**

AQ30, 31, 40, 41  
AD30, 31, 40, 41  
TAMD30, 31, 40, 41, 42, 43, 44, 300



CABLE DE MASA MASS CABLE CAVO DI MASSA	R.O. OEM
REC968048	968048

**NEW**



Ref.	R.O. OEM	kw	V	DIENTES TOOTH DENTI	SOLENOIDE SOLENOID SOLENOIDE
PH140-0004	3854190	1.4	12	10	PH375-0009
	841066				

**MOTORES / ENGINES / MOTORI**

FORD 5.0 & 5.8L  
Con 2 Tornillos de anclaje.  
With 2 bolt  
Con 2 viti di supporto

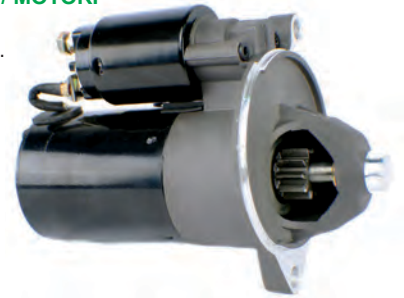

Ref.	R.O. OEM	kw	V	DIENTES TOOTH DENTI
REC3840888	3840888	0.95	12	8
	3803904			

**MOTORES / ENGINES / MOTORI**

MD2010A, B, C, D  
MD2020A, B, C, D  
D1-13, B, F  
D1-20, B, F

**NEW**



Ref.	R.O. OEM	kw	V	DIENTES TOOTH DENTI
REC3848965	3848965			
	3801204		12	9
	30782228			

**MOTORES / ENGINES / MOTORI**

D3-110 --> D3-190



Ref.	R.O. OEM	kw	V	DIENTES TOOTH DENTI
REC21423488	21423488			
	3801296			
	3803938			
	3803648			
	3588491		12	11
	874501			
	3803855			
	3804296			

**MOTORES / ENGINES / MOTORI**

D4, 6



Ref.	R.O. OEM	KW	V	DIENTES TOOTH DENTI	VOLANTE FLYWHEEL VOLANTE	SOLENOIDE SOLENOID SOLENOIDE
PH140-0017-D	3885317					
	3857747	1.4	12	11	14"	PH375-0008
	3660566					

**MOTORES / ENGINES / MOTORI**

4 cyl  
V6 & V8  
3.0L

Motor de arranque para substituir a todos los motores de tamaño pequeño con tornillos fijación en diagonal excepto los 7.4L  
Starter to replace all the little engines with diagonally fixation screws excepting 7.4L.  
Motorino d'avviamento per sostituire tutti i motori V6 e V8 con motorini con viti di supporto trasversali eccetto i motori 7.4L



TORNILLO BOLT VITE	R.O. OEM
REC10-861788	10-861788

Ref.	R.O. OEM	KW	V	DIENTES TOOTH DENTI	VOLANTE FLYWHEEL VOLANTE	SOLENOIDE SOLENOID SOLENOIDE
PH140-0017-HT	3860764	1.7	12	11	14"	PH375-0005

**MOTORES / ENGINES / MOTORI**

Motor de arranque Heavy Duty. Tornillos de fijación en diagonal. Para todos los motores V-6 y V-8, y especialmente los 7.4 L.

Starter with diagonally fixation screws. For all engines V6 & V8, specially 7.4L.  
Motorino d'avviamento Heavy Duty con viti di supporto trasversali. Per tutti i motori V-6 e V-8, consigliato per i 7.4L.



TORNILLO BOLT VITE	R.O. OEM
REC10-861788	10-861788

Ref.	R.O. OEM	V	DIENTES TOOTH DENTI	SOLENOIDE SOLENOID SOLENOIDE
PH140-0013	835121			
	834893	12	9	PH375-0004
	855326			

**MOTORES / ENGINES / MOTORI**

Modelo antiguo. Motor de arranque 4 en línea, V6 & V8 (Tornillos sujeción misma altura).

Old style. Starter heavy duty standard rotation 4 inline, V6 & V8. In line mounting holes.

Modello vecchio. Motorino d'avviamento 4 in linea, V6 & V8 (Viti di supporto parallele)



TORNILLO BOLT VITE	R.O. OEM
MP0180-000	10-812509184
REC10-861788	10-861788

Ref.	R.O. OEM	V	DIENTES TOOTH DENTI	VOLANTE FLYWHEEL VOLANTE	SOLENOIDE SOLENOID SOLENOIDE
PH140-0015	3850525				
	3853982	12	9	14 1/4"	PH375-0004

**MOTORES / ENGINES / MOTORI**

Motor de arranque para V6 y V8 con tornillos sujeción en diagonal.  
Starter to V6 & V8 heavy duty standard rotation. Offset mounting holes  
Motorino d'avviamento per V6 e V8 con viti di supporto trasversali.



TORNILLO BOLT VITE	R.O. OEM
REC10-861788	10-861788



Ref.	R.O. OEM	KW	V	DIENTES TOOTH DENTI	VOLANTE FLYWHEEL VOLANTE	SOLENOIDE SOLENOID SOLENOIDE
PH140-0020	3854750 3856003	1.4	12	9	12 <sup>3/4"</sup>	PH375-0008

**MOTORES / ENGINES / MOTORI**

V6 & V8

Motor de arranque pequeño 4 en línea.

Starter Clockwise for 4L.

Motorino d'avviamento  
(viti di supporto trasversali).



TORNILLO BOLT VITE	R.O. OEM
MP0180-001	
REC10-861788	10-861788



Ref.	R.O. OEM	KW	V	DIENTES TOOTH DENTI	SOLENOIDE SOLENOID SOLENOIDE
PH140-0020-D	3862308	1.4	12	11	PH375-0008

**MOTORES / ENGINES / MOTORI**

3.0L V6, V8



TORNILLO BOLT VITE	R.O. OEM
MP0180-001	
REC10-861788	10-861788



Ref.	R.O. OEM	KW	V	DIENTES TOOTH DENTI
PH140-0022	841377	1.4	12	9

**MOTORES / ENGINES / MOTORI**

4, 6 & 8 cyl

Motor de arranque 4 en línea modelo 470.

Starter clockwise 4 in line 470 mod. and engines with transmission.

Motorino d'avviamento 4 in linea modello 470.



Ref.	R.O. OEM	KW	V	DIENTES TOOTH DENTI
PH140-0022-CCW	21129980 3862985	1.4	12	9

**MOTORES / ENGINES / MOTORI**

4, 6 & 8 cyl

5.7 MIE / 6.2 MIE.

Contrarrotación o montaje en campana.

Starter counter clockwise.

Controrrotante, posizionato nella campana.



**EXTENSOR DE SOLENOIDE PARA TERMINALES  
SOLENOID EXTENSOR FOR TERMINALS  
PROLUNGA TERMINALE PER SOLENOIDE**

Ref.	R.O. OEM
PH365-0006	



**LLAVES DE ARRANQUE  
START KEYS  
CHIAVE DI AVVIAMENTO**

Ref.	R.O. OEM	PANELES PANELS PANNELLI	TERMINALES TERMINALS TERMINALI	POSICIONES POSITIONS POSIZIONE
REC3587071	3587071			
RM3587072	3587072			
MP39200	856659	28 mm	3	3



MP39200

**NEW**



RM3587071

**NEW**



RM3587072

**ALTERNADORES  
ALTERNATORS  
ALTERNATORI**

Ref.	R.O. OEM	
REC3884858	3884858 3803577 3803940	14 V 130A

**NEW**

**MOTORES / ENGINES / MOTORI**  
D12, 31, 41, 61, 62, 63, 71, 72, 74



Ref.	R.O. OEM	GROOVE
REC874502	874502 3803650 3840181 3803911 3587216 3803846	14V 115A 6

**MOTORES / ENGINES / MOTORI**

D1-30, B, F  
D2-40, B, F  
D2-55, C, D, E, F  
D2-60F  
D2-75, B, C, F  
D4  
D6

**NEW**



Ref.	R.O. OEM	GROOVE
REC8676498	8676498 3803645	12V 140A 6

**MOTORES / ENGINES / MOTORI**  
D3-110 --> D3-190

**NEW**



Ref.	R.O. OEM	V
PH300-0008-D	873770	12V 63A

Alternador tipo Delco. Con terminal cuentavueltas y polea simple.  
Regulador autoexcitante  
Delco Type Alternator. With tachometer terminal & simple pulley  
Self-exciting regulator.  
Alternatore tipo Delco.  
Con terminale per contagiri e puleggia singola.  
Regolatore interno  
RED +  
BLACK exc  
WHITE tach



Ref.	R.O. OEM		GROOVE
REC31419556	31419556 30667118 30659131	12V 150A	5

**MOTORES / ENGINES / MOTORI**

D3-110 --> D3-220



Ref.	R.O. OEM	V
PH300-0014	83857561 3860171	12V 65A

**MOTORES / ENGINES / MOTORI**

3.0, 4.3, 5.0, 5.7, 5.8, 7.4, 8.2

Con regulador interior y polea simple.

Mando Original

With internal regulator and single pulley. Original Mando

Con regolatore interno e puleggia normale. Mando Originale.



Ref.	R.O. OEM		GROOVE
REC3819662	3819662 3803903	12V 115 A	5

**MOTORES / ENGINES / MOTORI**

D1-13, B, F

D1-20, B, F



Ref.	R.O. OEM	V
PH300-0015	3857813	12V 65A

**MOTORES / ENGINES / MOTORI**

3.0, 4.3, 5.0, 5.7, 5.8, 7.4, 8.2

Con regulador interior y polea serpentín.

Mando Original

With internal regulator and serpentine pulley. Original Mando

Con regolatore interno e puleggia serpentina. Originale Mando



Ref.	R.O. OEM	V
PH300-0017	3862612 3860798	12V 65A

**MOTORES / ENGINES / MOTORI**

8.1GiA, B, BF, C, CF, D, DF

8.1GXi-A, AF, B, BF, C, CF

8.1GXii-A, B, C

8.1GSi-A,

8.1Giil-A, B, C, D.

Con regulador interior y polea

serpentin. Mando original

With internal regulator and serpentine pulley. Original Mando

Con regolatore interno e puleggia serpentina. Originale Mando



Ref.	R.O. OEM	V
PH300-0036	3862612	12V 65A

**MOTORES / ENGINES / MOTORI**

4.3 GLM - E, EF

5.0GL - F, FF

Con regulador interior y polea simple. Delco original

With internal regulator and single pulley. Original Delco

Con regolatore interno e puleggia normale. Delco Originale.



Ref.	R.O. OEM	V
PH300-0010	3860769 3854809	12V 55A

**MOTORES / ENGINES / MOTORI**

GM 3.0, 4.3, 5.7, 7.4, 8.2

Ford 5.0, 5.8

Con regulador interior y polea simple.

With internal regulator and single pulley.

Con regolatore interno e puleggia normale.



Ref.	R.O. OEM		GROOVE
PH300-0037	3862665 3884950 3862613	12V 65A	6

**MOTORES / ENGINES / MOTORI**

3.0GLP-A, B

3.0GLM-A, B

4.3 & 5.7 EFI

Con regulador interior y polea serpentín. Delco original

With internal regulator and serpentine pulley. Original Delco

Con regolatore interno e puleggia serpentina. Originale Delco



Ref.	R.O. OEM	
PH300-0027-OE	873770	12V 60A

Alternador original VALEO con regulador interior.  
Prácticamente para todos los motores diesel y gasolina con alternador.  
No incluye polea **RM841812**

VALEO Original Alternator with internal regulator.  
For almost all diesel and gas engines with alternators  
PULLEY **RM841812** not included.

Alternatore originale VALEO con regolatore interno.  
Utilizzabile per la maggior parte dei motori diesel e benzina con  
alternatore.

Non incluso puleggia **RM841812**



POLEA PARA ALTERNADOR VALEO PH300-0027-OE  
PULLEY FOR VALEO ALTERNATOR PH300-0027-OE  
PULEGGIA PER ALTERNATORE VALEO PH300-0027-OE

Ref.	R.O. OEM	
RM841812	841812	



## RELÉS RELAYS RELE

Ref.	R.O. OEM	
REC3861375	3861375	12V

**MOTORES / ENGINES / MOTORI**

3.0L, V6, V8  
Modelos nuevos  
New models  
Modelli nuovi



Ref.	R.O. OEM	
REC1324492	1324492	12V 30A

**MOTORES / ENGINES / MOTORI**

115, 130, 165  
MD1, 21, 71



Ref.	R.O. OEM	
REC3858081	3858809	

**MOTORES / ENGINES / MOTORI**

(1998 SX-M-MAC, MDA, MLT) DPH-A, H-B, R-A  
3.0GLP-D EF drives  
4.3GL-E, GL-EF, GXi-F, GXi-FF, OSi-F, SX-M TSKs 1998-05,  
OSi-FF SX-M  
5.0GL-F, GL-FF, GXi-F, GXi-FF, Si-F, DP-SM, (WT drives, PJX-C, PJX-S SX-  
Si-FF, Gi-F/FF, GXi-G/GF, OSi-E/EF, M, MACLT, -MDA, -MDB, -MPH, -MTD,  
OXi-E/EF, GXi-F, GXi-G DP-E, DP-S, -S1, -S2, DP-SM, -SM)  
8.1Gi-G/GF, GXi-F/FF, OSi-C/CF, XDP-B  
GiL-G, GXiL-F TRIM



**STARTER TRIM/TILT**

Ref.	R.O. OEM	
RM3841366	3841366	

**MOTORES / ENGINES / MOTORI**

4 cyl, V6, V8  
Modelos nuevos  
New models  
Modelli nuovi



Ref.	R.O. OEM	
REC1504952	1504952	12V 30A

**MOTORES / ENGINES / MOTORI**

MD22, 63, 71, 73, 74  
30, 40, 61, 70  
V8



Ref.	R.O. OEM	
REC876040	876040	12V 30A

**MOTORES / ENGINES / MOTORI**

131, 145, 175, 250  
V8  
TMD30, 40

Para / for / per: TRI MEST-1089



Ref.	R.O. OEM	
PH360-0003	876037	12V 30A

**MOTORES / ENGINES / MOTORI**  
2010, 2020, 2030, 2040  
30, 31, 40, 41, 42, 102, V8



Ref.	R.O. OEM	
REC841177	841177	12V 30A

**MOTORES / ENGINES / MOTORI**  
V6, V8, 2001, 2002, 2003  
AQ125B  
AQ131A, B, C, D  
AQ145B  
AQ151A, B, C



Ref.	R.O. OEM	
REC22637542	22637542 846762 873740 860339	12V 70A

**MOTORES / ENGINES / MOTORI**  
2003  
MD22  
D3  
TMAD22  
D30, 31, 32, 40, 41,  
42, 43, 44



**RELÉ STARTER  
FUZE STARTER  
RELÈ STARTER**

Ref.	R.O. OEM	
REC3854138	3854138	12V

**MOTORES / ENGINES / MOTORI**  
3.0, 4.3, 5.0, 5.7, 5.8, 7.4



**RELÉ CAJA FUSIBLES  
FUSES BOX RELAY  
RELÈ DELLA SCATOLA FUSIBILE**

Ref.	R.O. OEM	
REC3861376	3861376	12V

**MOTORES / ENGINES / MOTORI**  
V6, V8  
Modelos nuevos  
New models  
Modelli nuovi

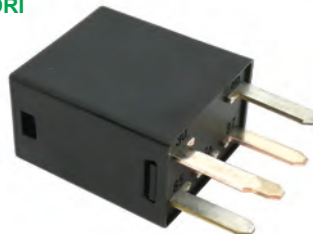

**PARADA DE EMERGENCIA  
EMERGENCY STOP  
ARRESTO DI EMERGENZA**

Ref.	R.O. OEM	
REC21400091	21400091 873765 11305263	12V

**MOTORES / ENGINES / MOTORI**  
KAD  
D(EVC)



**RELÉ BOMBA GASOLINA ELÉCTRICA  
RELAY FOR FUEL ELECTRIC PUMP  
RELE POMPA BENZINA ELETTRICA**

Ref.	R.O. OEM	
REC3857533	3857533	

**MOTORES / ENGINES / MOTORI**  
4.3, 5.0, 5.7, 7.4, 8.2



**FUSIBLE  
FUZE  
FUSIBILE**

Ref.	R.O. OEM	AMP
REC3819905	3819905 856355 853502 852939	55A

**MOTORES / ENGINES / MOTORI**  
D22, 30, 31, 32, 40, 41, 42, 43, 44, 300  
230, 250, 500, 501, 430, 431, 432  
AQ131 --> AQ311



**FUSIBLE MOTOR  
FUZE ASSEMBLY  
FUSIBILE MOTORE**

Ref.	R.O. OEM	V
PH365-0003		110A
RM88-79023A91		90A

**FUSIBLE ATM  
ATM FUZE  
FUSIBILE ATM**

Ref.	AMP	
AM603905	5 A	2
AM603910	10 A	2
AM603915	15 A	2
AM603920	20 A	2
AM603930	30 A	2



**FUSIBLE ATC  
ATC FUZE  
FUSIBILE ATC**

Ref.	AMP	
BS5291	3 A	2
BS5299	4 A	2
BS5292	5 A	2
BS5293	7,5 A	2
BS5294	10 A	2
BS5295	15 A	2
BS5296	20 A	2
BS5297	25 A	2
BS5298	30 A	2



**FUSIBLE MAXI  
MAXI FUSE  
FUSIBILE MAXI**

Ref.	AMP	
BS5138	30 A	2
BS5139	40 A	2
BS5140	50 A	2
BS5141	60 A	2
BS5142	70 A	2
BS5143	80 A	2



**NEW**

**FUSIBLE TÉRMICO MOTOR  
IGNITION CIRCUIT BREAKER  
FUSIBILE TERMICO MOTORE**

Ref.	R.O. OEM	
BS2141	841178	40A
BS2142	3854164	50A
BS2143	3854186	60A



**NEW**

**SOLENOIDES  
SOLENOID  
SOLENOIDE**

Ref.	R.O. OEM	STARTER
PH375-0013	859618	12V PH150-0007 PH150-0007-OE



Ref.	R.O. OEM	
PH375-0028	852565	



**MOTORES / ENGINES / MOTORI**  
AQD30, 31, 40, 41  
AQ131A, B, C, D  
AQ145A, B  
AQ151A, B, C  
AQ171A, C  
175A, 205, 231, 260

Ref.	R.O. OEM	STARTER
PH375-0009	3854194	12V PH140-0004 PH140-0004-CCW



Ref.	R.O. OEM	
PH375-0027	3853839	12V



**MOTORES / ENGINES / MOTORI**  
5.0 & 5.8 Ford FI/FL

**NEW**

Ref.	R.O. OEM	STARTER
PH375-0004		7,5 cm PH140-0013
PH375-0001		9,5 cm

DELCO REMY



**SOLENOIDES PARADA INYECTORA  
STOP SOLENOID  
SOLENOIDI D'ARRESTO INNIETORE**

Ref.	R.O. OEM	
REC876614	876614	50A

**NEW**

**MOTORES / ENGINES / MOTORI**  
KAD32P-A, 42A, 42B, 42P-A, 43P-A, 44P-A, 44P-B, 44P-C, 300-A  
KAMD42B, 42P-A, 43P, 43P-A, 43P-B, 300-A  
TAMD22A, 22P-B, 31B, 31D, 31M-A, 31P-A, 31S-A, 41B, 41D, 42B, 42WJ-A, 41H-A, 41H-B, 41P-A, 41L-A, 41M-A, 42A  
AD31B, 31D-A, 31L-A, 31P-A, 31XD, 41B, 41D, 41L-A, 41P-A  
D41B, 41D, 41L-A  
TMD22-A, 22-B, 22P-C, 31D, 31L-A, 31B, 41D, 41L-A  
MD22A, 22A-A, 22L-A, 22L-B, 22P-B, 31A  
MS2A-E, 2B-A, 2B-R, 2A-E, 2B-L, 2L-E, 120S-E  
TM41B  
120S-E

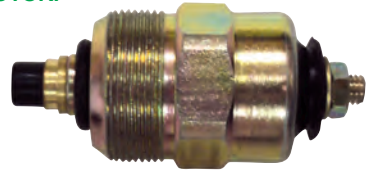

Ref.	R.O. OEM	STARTER
PH375-0008		PH140-0017-D PH140-0020-D



Ref.	R.O. OEM	
REC3584127	3584127	

**NEW**

**MOTORES / ENGINES / MOTORI**  
D1-13, B, F  
D1-20, B, F  
D1-30, B, F  
D2-40, B, F  
D2-55F, B, D, D, E  
D2-60F  
D2-75F, B, C



# TRIM

## MOTOR TRIM COMPLETO COMPLETE TRIM MOTOR MOTORE TRIM COMPLETO

Ref.	R.O. OEM		MOTOR ENGINE MOTORE	CABLES WIRES CAVI
PH200-T017	3586765	12V	PH200-T007	2
	854346			
	3857265			
	3861027			

### MOTORES / ENGINES / MOTORI

Para colas 280-290 y versiones antiguas SX.  
For 280-290 drives and SX early versions.  
Fine thread.  
Per piedi 280-290 e versione vecchia SX.



Ref.	R.O. OEM		MOTOR ENGINE MOTORE	CABLES WIRES CAVI
REC3587079	3587079	12V	PH200-T012	2
	3857079			
	3857489			
	3858069			
	3860879			

### MOTORES / ENGINES / MOTORI

Para colas SX última versión con rosca gruesa.  
Complete trim motor for SX drive late model with coarse thread.  
Per piedi SX ultima versione.



Ref.	R.O. OEM		MOTOR ENGINE MOTORE	CABLES WIRES CAVI
PH200-T027	3586765	12V		3
	852928			

### MOTORES / ENGINES / MOTORI

Modelo antiguo  
Old Style Complete Trim Motor  
Modello vecchio



## MOTOR TRIM HIDRÁULICO HYDRAULIC TRIM MOTOR MOTORE TRIM IDRAULICO

Ref.	R.O. OEM		KIT	CABLES WIRES CAVI
PH200-T007	3858071	12V	PH200-T017	2

### MOTORES / ENGINES / MOTORI

Para colas 280-290 y versiones antiguas SX.  
For 280-290 drives and SX early versions.  
Fine thread.  
Per piedi 280-290 e versione vecchia SX.



## MOTOR TRIM MECÁNICO MECHANIC TRIM MOTOR MOTORE TRIM MECCANICO

Ref.	R.O. OEM		CABLES WIRES CAVI
PH200-T028	850834	12V	2



## MOTOR TRIM SX SX TRIM MOTOR MOTORE TRIM SX

Ref.	R.O. OEM		TORNILLOS SCREWS VITI	CABLES WIRES CAVI
PH200-T023	3853945	12V	3	2

### MOTORES / ENGINES / MOTORI

1994 +



## MOTOR TRIM / TILT TRIM / TILT MOTOR MOTORE TRIM / TILT

Ref.	R.O. OEM		KIT	CABLES WIRES CAVI
PH200-T012	3861575	12V	REC3587079	2

### MOTORES / ENGINES / MOTORI

Para colas SX última versión con centros de tornillos a 58,4 mm.  
Later version 2.3" bolt centers w/coarse thread  
Per piedi SX ultima versione con misura interna delle viti da 58,4 mm.



### CONVERTIDOR DE 3 A 2 CABLES 3 TO 2 WIRE WIRED CONVERTER CONVERTITORE CAVI DA 3 A 2 FILI

Ref.
PH200-WH01



### ACEITE TRIM / TILT POWER TRIM & TILT FLUID OLIO TRIM / TILT

LUB11578U12



## DEPÓSITO TRIM TRIM TANK SERBATOIO TRIM

Ref.	R.O. OEM	TORNILLOS SCREWS VITI
PH200-T064-1B	854531	1



Ref.	R.O. OEM	TORNILLOS SCREWS VITI	Ø
REC883166A2	3861570	4	97 mm
REC3858077	3858077	4	99 mm



**NEW**

## PISTÓN TRIM TRIM PISTON PISTONE TRIM

Ref.	R.O. OEM
RM3857471	3857471

MOTORES / ENGINES / MOTORI  
SX-MLT, MACLT



Ref.	R.O. OEM
RM3860881	3860881 872837

Con terminal ojal.  
With eye terminal.  
Terminale ad occhio



Ref.	R.O. OEM
REC22187386	22187386 3779955

MOTORES / ENGINES / MOTORI  
SX-A, DPS-A  
TILT total Estribor  
Full TILT STD  
Tutto TILT Destra



**NEW**

Ref.	R.O. OEM
REC22187385	22187385 3889954

MOTORES / ENGINES / MOTORI  
SX-A, DPS-A  
TILT total Babor  
Full TILT Port  
Tutto TILT Sinistra



**NEW**

Ref.	R.O. OEM
REC21840806	21840806 3888301 3857470

MOTORES / ENGINES / MOTORI  
DPH, DPR  
Estribor / Stb / Destra



**NEW**

Ref.	R.O. OEM
REC22121309	22121309 21840807 3887960

MOTORES / ENGINES / MOTORI  
DPH, DPR  
Babor / Port / Sinistra



**NEW**

## KIT PISTÓN TRIM TRIM PISTON KIT KIT PISTONE TRIM

Ref.	R.O. OEM
RM3885196	3885196 3850683

Para substituir los pistones (R.O. 3852414) de colas SX  
To replace the original piston (OEM 3852414)  
Per sostituire i pistoni del piedi SX (R.O. 3852414)



Ref.	R.O. OEM
RM872612-7	872612 854610 853439

Con terminal de horquilla.  
With terminal.  
Terminale a forcella

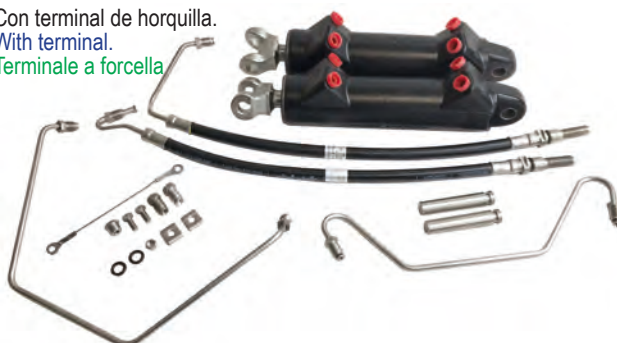



**TUBO CILINDRO TRIM  
TRIM CYLINDER TUBE  
TUBO CILINDRO TRIM**

Ref. R.O. OEM

RMTUBOVOLVO

Pistones antiguos:  
Oil piston:

Pistone vecchio:

852755, 854610, 853308, 853309, 854550



Ref. PARA FOR PER  
REC19088 REC21840806  
REC22121309



**NEW**



Ref. PARA FOR PER  
REC22169 REC21840806  
REC22121309

MOTORES / ENGINES / MOTORI  
DPH, DPR



**NEW**



**KIT REPARACIÓN PISTÓN TRIM  
REPAIR KIT TRIM PISTON  
KIT RIPARAZIONE PISTONE TRIM**

Ref. PARA FOR PER  
RECKITDP RM3860881



Ref. PARA FOR PER  
RECKITDP2 RM872612



Ref. PARA FOR PER  
REC22172 REC22187386  
REC22187385

MOTORES / ENGINES / MOTORI  
DPS-A  
SX-A



**NEW**

Ref. R.O. OEM  
REC3854247 3854247

MOTORES / ENGINES / MOTORI  
SX  
DP-SM  
SX-M, S, C



**NEW**

**DESPIECE TRIM  
TRIM COMPONENTS  
ESPLOSO TRIM**

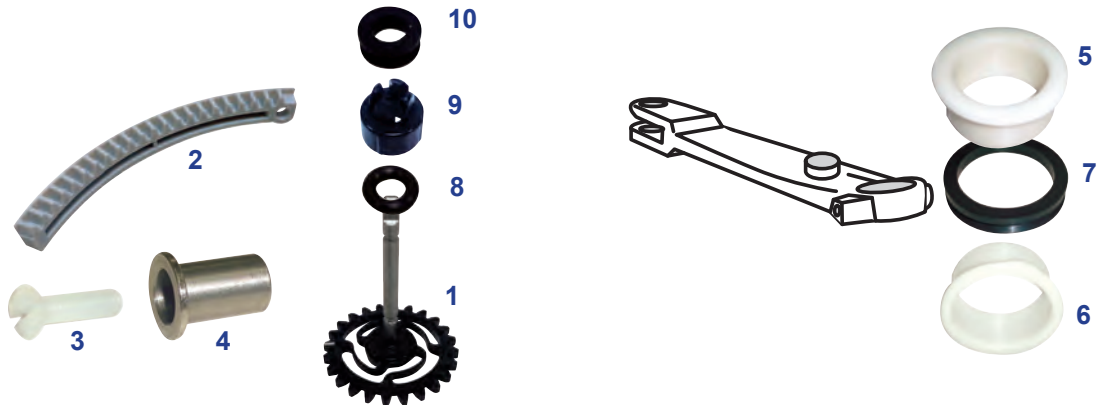

Nº	Ref.	R.O. OEM	Descripción	Description	Descrizione
1	RM852984-4	852984	PIÑÓN INDICADOR	DRIVE GEAR	PIGNONE INDICATORE TRIM
2	REC872812	872812	CREMALLERA TRIM	GEAR SEGMENT	CREMAGLIERA
3	REC853759	853759	TORNILLO CREMALLERA	SEGMENT SCREW	VITE CREMAGLIERA
4	REC853760	853760	CASQUILLO TORNILLO CREMALLERA	RIVET NUT	BOCCOLA
5	RM872363	872363	CASQUILLO BIELA DIRECCIÓN SUPERIOR (ESTRIADA)	UPPER BUSHING (SPLINE)	BOCCOLA BIELLA SUPERIORE (SCANALATA)
5	RM854705	854705	CASQUILLO BIELA DIRECCIÓN SUPERIOR (CUADRADA)	UPPER BUSHING (SQUARE)	BOCCOLA BIELLA SUPERIORE (QUADRATA)
6	REC872362	872362	CASQUILLO BIELA DIRECCIÓN INFERIOR (ESTRIADA)	LOWER BUSHING (SPLINE)	BOCCOLA BIELLA INFERIORE (SCANALATA)
6	RM854704	854704	CASQUILLO BIELA DIRECCIÓN INFERIOR (CUADRADA)	LOWER BUSHING (SQUARE)	BOCCOLA BIELLA INFERIORE (QUADRATA)
7	REC839195	839195	RETÉN BIELA DIRECCIÓN (HORQUILLA ESTRIADA)	RING (SPLINE)	PARAOLIO BIELLA (FORCELLA SCANALATA)
7	RM977313	977313	RETÉN BIELA DIRECCIÓN (HORQUILLA CUADRADA)	RING (SQUARE)	PARAOLIO BIELLA (FORCELLA QUADRATA)
8	REC925050	925050	ARANDELA	O-RING	RONDELLA
9	REC851430	851430	CASQUILLO	BUSHING	BOCCOLA
10	REC966207	966207	RETÉN	SEAL	PARAOLIO

## LATIGUILLOS TRIM TRIM HOSES TUBI TRIM

DE BOMBA A TRANSOM  
FROM PUMP TO TRANSOM  
DALLA POMPA AL TRANSOM

Ref.	R.O. OEM
REC852839	852839



DE TRANSOM A PISTÓN  
FROM TRANSOM TO PISTON  
DEL TRANSOM AL PISTONE

Ref.	R.O. OEM
RM857624	857624



DE BOMBA A PISTÓN  
FROM PUMP TO PISTON  
DALLA POMPA AL PISTONE

Ref.	R.O. OEM
REC873228	873228
REC873229	873229

MOTORES / ENGINES / MOTORI  
DP, DPX



REC873228

REC873229

KIT LATIGUILLOS DE BOMBA A PISTÓN  
KIT HOSES FROM PUMP TO PISTON  
KIT TUBI DALLA POMPA AL PISTONE

Ref.	R.O. OEM
REC21945911	21945911 3884410

MOTORES / ENGINES / MOTORI  
SX-A



DE BOMBA A COLECTOR  
PUMP TO MANIFOLD  
DALLA POMPA AL DISTRIBUTORE

Ref.	R.O. OEM
RM3853825	3853825

MOTORES / ENGINES / MOTORI  
SX



DE COLECTOR A CILINDRO BABOR (SUBIDA)  
DRIVES MANIFOLD TO CYLINDER PORT (UP)  
TUBO CILINDRO DI SINISTRA (SALITA)

Ref.	R.O. OEM
REC3853857	3853857

MOTORES / ENGINES / MOTORI  
SX



DE COLECTOR A CILINDRO BABOR (BAJADA)  
DRIVES MANIFOLD TO CYLINDER PORT (DOWN)  
TUBO CILINDRO DI SINISTRA (DISCESA)

Ref.	R.O. OEM
REC3853856	3853856

MOTORES / ENGINES / MOTORI  
SX

Excluidas / except / eccetto: SXM, MAC, MDA, MDB, MLT



Ref.	R.O. OEM
REC3857523	3857523

MOTORES / ENGINES / MOTORI  
SX SXM, MAC, MDA, MDB, MLT  
DPS SXM, MAC, MDA, MDB, MLT

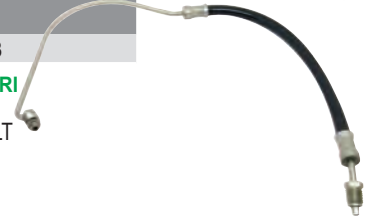

DE COLECTOR A CILINDRO ESTRIBOR (SUBIDA)  
DRIVES MANIFOLD TO CYLINDER STD (UP)  
TUBO CILINDRO DI DESTRA (SALITA)

Ref.	R.O. OEM
REC3853855	3853855

MOTORES / ENGINES / MOTORI  
SX



DE COLECTOR A CILINDRO ESTRIBOR (BAJADA)  
DRIVES MANIFOLD TO CYLINDER STD (DOWN)  
TUBO CILINDRO DI DESTRA (DISCESA)

Ref.	R.O. OEM
REC3853854	3853854

MOTORES / ENGINES / MOTORI  
SX

Excluidas / except / eccetto:  
SXM, MAC, MDA, MDB, MLT SX/DPS



Ref.	R.O. OEM
REC3857524	3857524

MOTORES / ENGINES / MOTORI  
SX SXM, MAC, MDA, MDB, MLT



DE CILINDRO TRIM A BOMBA TRIM  
CYLINDER TO TRIM PUMP  
DA CILINDRO TRIM A POMPA TRIM

Ref.	R.O. OEM
REC21721548	21721548, 3809559
REC21721550	21721550, 3809560

MOTORES / ENGINES / MOTORI  
DPH-A, -B  
DPR-A, -B



REC21721550

REC21721548

**LATIGUILLOS TRIM Y COMPONENTES SX-C, SX-R, SX-S**  
**TRIM HOSES & COMPONENTS SX-C, SX-R, SX-S**  
**ESPLOS COPENENTI TRIM SX-C, SX-R, SX-S**

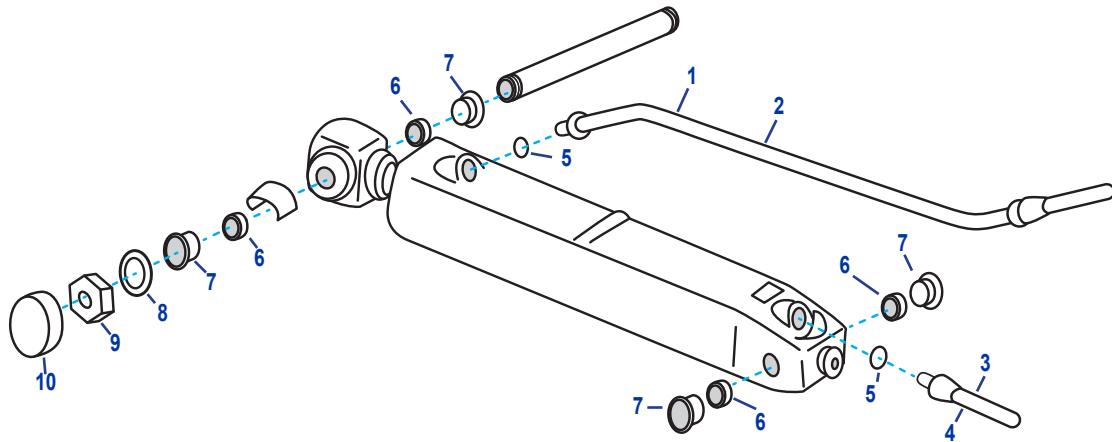

Nº	Ref.	R.O. OEM	Descripción	Description	Descrizione
1	REC3853854	3853854	LATIGUILLO TRIM ESTRIBOR BAJADA	TRIM HOSE STARBOARD DOWN	TUBO IDRAULICO DESTRA DISCESA
2	REC3853856	3853856	LATIGUILLO TRIM BABOR BAJADA	TRIM HOSE PORT DOWN	TUBO IDRAULICO SINISTRA DISCESA
3	REC3853855	3853855	LATIGUILLO TRIM ESTRIBOR SUBIDA	TRIM HOSE STARBOARD UP	TUBO IDRAULICO DESTRA SALITA
4	REC3853857	3853857	LATIGUILLO TRIM BABOR SUBIDA	TRIM HOSE PORT UP	TUBO IDRAULICO SINISTRA SALITA
5	REC3852165	3852165	ARO TÓRICO	O-RING	O-RING
6	RM3853424	3853424	ARO	RING	O-RING
7	REC3853423	3853423	CASQUILLO HORQUILLA	BUSHING	BOCCOLA
8	RM3852573	3852573	ARANDELA	WASHER	RONDELLA
9	RM3852648	3852648	TUERCA	NUT	DADO
10	RM3852958	3852958	TAPA	CAP	COPERCHIO

**LATIGUILLOS TRIM Y COMPONENTES SX-M**  
**TRIM HOSES & COMPONENTS SX-M**  
**ESPLOS COPENENTI TRIM SX-M**

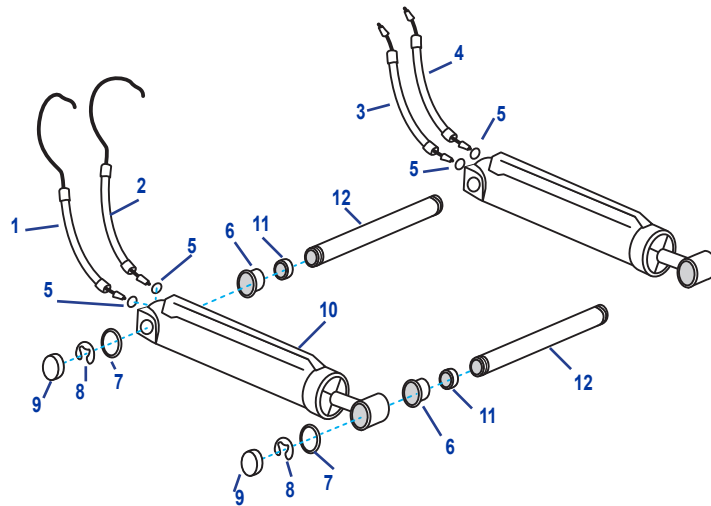

Nº	Ref.	R.O. OEM	Descripción	Description	Descrizione
1	REC3857523	3857523	LATIGUILLO TRIM	TRIM HOSE	TUBO IDRAULICO
2	REC3853857	3853857	LATIGUILLO TRIM	TRIM HOSE	TUBO IDRAULICO
3	REC3857524	3857524	LATIGUILLO TRIM	TRIM HOSE	TUBO IDRAULICO
4	REC3853855	3853855	LATIGUILLO TRIM	TRIM HOSE	TUBO IDRAULICO
5	REC3852165	3852165	ARO TÓRICO	O-RING	O-RING
6	REC3853423	3853423	CASQUILLO HORQUILLA	BUSHING	BOCCOLA
7	RM3857588	3857588	ARANDELA	WASHER	RONDELLA
8	REC3857521	3857521	CLIP	CLIP	CLIP
9	REC3857522	3857522	TAPA	CAP	COPERCHIO
10	RM3857470	3857470	PISTÓN TRIM	TRIM PISTON	PISTONE TRIM
11	RM3853424	3853424	ARO	RING	O-RING
12	RM3857431	3857431	PASADOR	COTTER PIN	CHIAVISTELLO

**HERRAMIENTA PARA TUERCA  
TOOL FOR END NUT  
STRUMENTO PER DADO**

Ref.	R.O. OEM	PARA PISTONES FOR PISTONS PER PISTONI
REC19876		RM3860881 RM872612-7



**INTERRUPTOR TRIM  
TRIM SWITCH  
INTERRUTTORE TRIM**

Ref.	R.O. OEM
REC3855650	3855650 876317 853846



**MOTORES / ENGINES / MOTORI**  
DP-D1, C, E, G  
DPX  
SP-C1, E  
SX

**PULSADOR TRIM MANDO  
TRIM CONTROL SWITCH  
INTERRUTTORE DI CONTROLLO DEL TRIM**

Ref.	R.O. OEM
REC3856844	3856844 3856839



**SOPORTE SENSOR TRIM  
TRIM SENSOR SUPPORT  
SUPPORTO SENSORE TRIM**

Ref.	R.O. OEM
REC3852555	3852555



**SENSOR INDICADOR TRIM  
TRIM POSITION SENDER  
SENSORE INDICATORE TRIM**

Ref.	R.O. OEM
REC22314183	873531 22314183 828726

**MOTORES / ENGINES / MOTORI**  
290, SP, DP

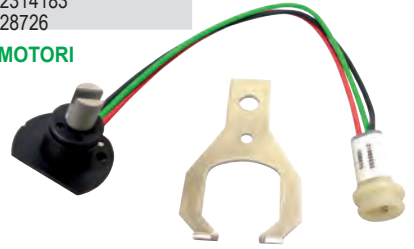

Ref.	R.O. OEM
REC21484383	21484383 3841840

**MOTORES / ENGINES / MOTORI**  
SX-A



Ref.	R.O. OEM
REC3858212	21652399 3858212

**MOTORES / ENGINES / MOTORI**  
SX  
(reloj digital europeo)  
(digital european gauge)  
(strumento digitale europeo)



Ref.	R.O. OEM	CABLES WIRES CAVI
REC3863007	3849411 3863007 3849413 3855535	3

**MOTORES / ENGINES / MOTORI**  
SX  
(reloj analógico europeo)  
(digital analogic gauge)  
(strumento analogico europeo)



**EXTRACTOR TAPONES DE TRIM  
TRIM PLUGS EXTRACTOR  
ESTRATTORE PER TAPPI DI TRIM**

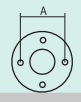

REF	Wrench	Size	A
RECTOOLTRIM1	1/2"	+RECPIN4+RECPIN4.5	38 mm
RECTOOLTRIM2	1/2"	+RECPIN4+RECPIN4.5	32 mm
RECTOOLTRIM3	1/2"	+RECPIN6	35 mm
RECTOOLTRIMKIT		RECTOOLTRIM1 + RECTOOLTRIM2 + RECTOOLTRIM 3	



new

**KITS DE RECAMBIO**  
Los pines de repuesto no tienen garantía.

**SPARE KITS**  
Replacement pins are not guaranteed.

**KIT DI RICAMBIO**  
I pini di ricambio non sono garantiti.

REF	Size
RECPIN4	3 PIN x 4 mm
RECPIN4.5	3 PIN x 4.5 mm
RECPIN6	3 PIN x 6 mm



Ref.	R.O. OEM	CABLES WIRES CAVI
REC3594989	3594989 3861837 3854842 3863129	2

**MOTORES / ENGINES / MOTORI**  
SX-M, LT, MDB, MHP, MACLT, MAC, MDC, MBAC



# PISTONES Y COMPONENTES DE DIRECCIÓN STEERING PISTONS & PARTS PISTONI IDRAULICI E COMPONENTI

## PISTÓN DIRECCIÓN STEERING PISTON PISTONE STERZO

Ref.	R.O. OEM
RM872215	872215

COLAS / STERDRIVES / PIEDI  
SP & DP

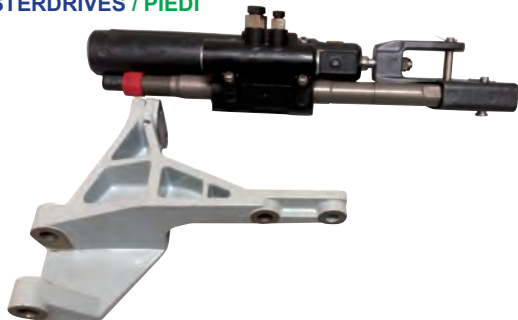

Ref.	R.O. OEM
RM3858128	3812269
	21910902
	3862513
	3862210
	3860883
	3860726

COLAS / STERDRIVES / PIEDI  
SX & DPS



Ref.	R.O. OEM
RM21745117	21745117
	22256625
	22452003

COLAS / STERDRIVES / PIEDI  
DPH-A, B, C, D, D1  
DPR-A, B, C

Instalación de gobierno electrónico  
Installation of electronic government  
Installazione del governo elettronico

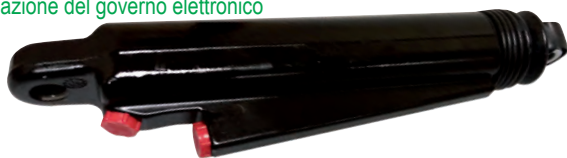

Ref.	R.O. OEM
REC22452005	22452005
	21745119

MOTORES / ENGINES / MOTORI

DPH-A, B, C, D, D1  
DPR-A, B, C, D  
Instalación de gobierno simple  
Simple government installation  
Installazione semplice



**NEW**

## ACTUADOR DE PISTÓN D4/D6 PISTON ACTUATOR D4/D6 ATTUATORE PISTONE D4/D6

Ref.	R.O. OEM
REC22663814	22663814
	21146097
	21505553

**NEW**

COLAS / STERDRIVES / PIEDI  
DPH  
DPR



## KIT LATIGUILLOS DIRECCIÓN HYDRAULIC HOSES KIT KIT TUBI STERZO

Ref.	R.O. OEM
RM21548739	21548739
	3863347
	3863405
	3863406
	3863407

MOTORES / ENGINES / MOTORI  
DPH, DPR

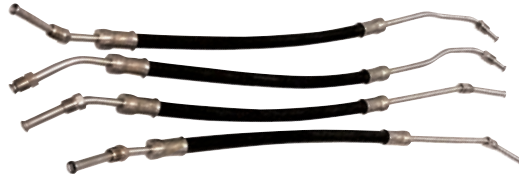

## KIT REPARACIÓN PISTÓN PISTON REPAIR KIT KIT RIPARAZIONE PISTONE

Ref.	R.O. OEM	CILINDRO CYLINDER CILINDRO
REC22170		REC22452005

**NEW**



Ref.	R.O. OEM	CILINDRO CYLINDER CILINDRO
REC22171		3861556

**NEW**



**KIT FUELLES PISTONES DIRECCIÓN**  
**KIT BELLOWS STEERING PISTON**  
**KIT CUFFIE PISTONE STERZO**

Ref.	R.O. OEM
RM21132674	21132674

**MOTORES / ENGINES / MOTORI**  
 DPH-A, B, C  
 DPR-A, B, C



**SERVO BOMBA**  
**SERVO PUMP**  
**SERVO POMPA**

Ref.	R.O. OEM
REC3887373	3887373

**MOTORES / ENGINES / MOTORI**  
 3.0 V6, V8  
 Nueva versión  
 New version  
 Nuova versione



**NEW**

Ref.	R.O. OEM
REC3884974	3884974 3860871

**MOTORES / ENGINES / MOTORI**  
 V6 GI, GL, GXI  
 V8 GI, GL, GXI



**NEW**

**CABLE RUDDER**  
**RUDDER CABLE**  
**CAVO RUDDER**

Ref.	R.O. OEM
REC3593951	3593951

**MOTORES / ENGINES / MOTORI**  
 DPH  
 DPR



**NEW**

**BOMBA HIDRÁULICA DIRECCIÓN**  
**HYDRAULIC STEERING PUMP**  
**POMPA IDRAULICA STERZO**

Ref.	R.O. OEM
RM3888323	3888323 3850491 3850492

**MOTORES / ENGINES / MOTORI**  
 3.0 GLP-E



**POLEA PARA SERVO BOMBA**  
**PULLEY FOR SERVO PUMP**  
**PULEGGIA PER SERVO POMPA**

Ref.	R.O. OEM	SERVO BOMBA SERVO PUMP SERVO POMPA
REC3853804	3853804	RM3888323

Correa dentada  
 Toothed belt  
 Cinghia dentata



**NEW**

# DESPIECE COLA GEARCASE COMPONENTS ESPLOSO PIEDE



IPS-A, B, C, D, E, F



Ref.	R.O. / OEM
CM40005875	Zn 40005875
CM40005875A	Al 23172849



Anodo  
Anode  
Anodo

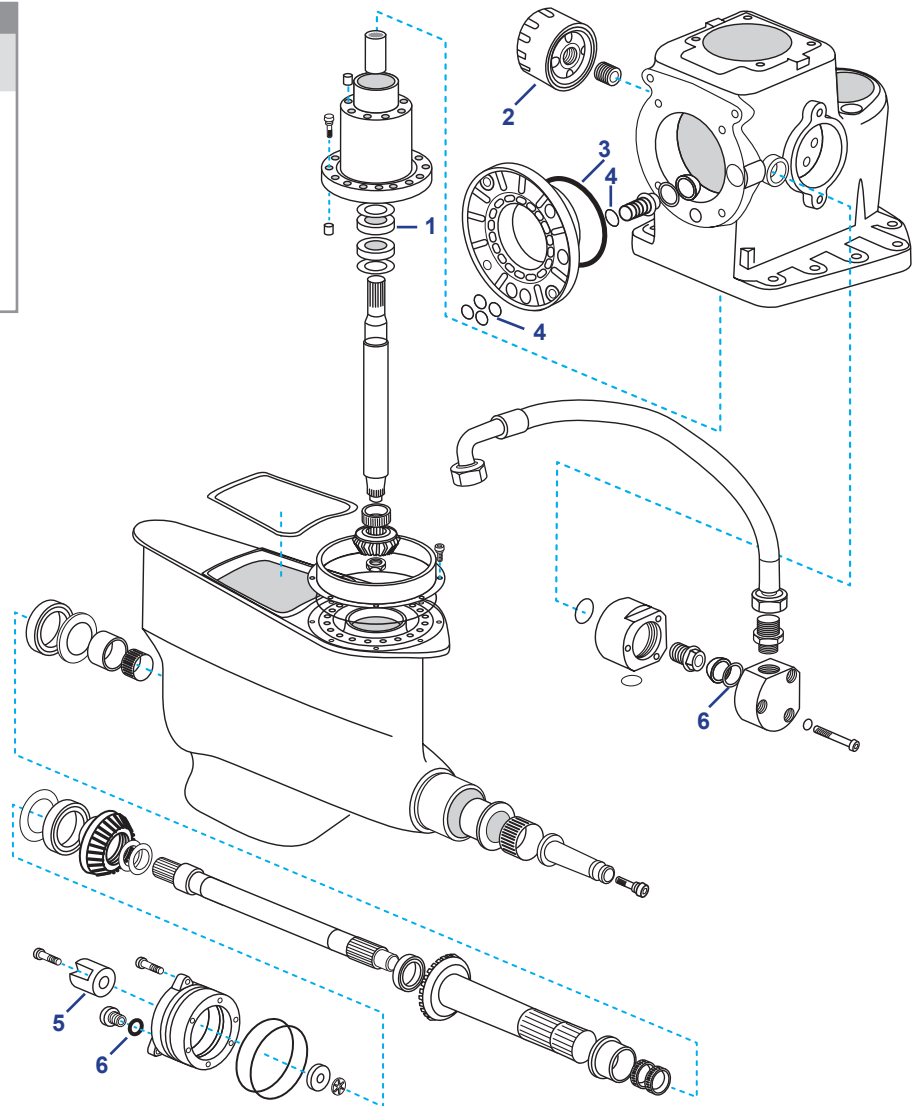

Ref.	R.O. / OEM
REC3812357	3812357



Kit Juntas  
Gasket kit  
Kit Guarnizione

Ref.	R.O. / OEM
REC22256171	22256171



Aro de goma  
Ring in rubber  
O-ring in gomma

Ref.	R.O. / OEM
REC22479648	22479648



PAG 480

Nº	Ref.	R.O. / OEM	Descripción	Description	Descrizione
1	REC3850852	3850852	COJINETE	BEARING	CUSCINETTO
2	REC834337	834337	FILTRO DE ACEITE	OIL FILTER	FILTRO OLIO
3	REC925260	925260	ARO TÓRICO	O-RING	O-RING
4	REC955989	955989	ARO TÓRICO	O-RING	O-RING
5	CM3593881	3593981	ÁNODO	ANODE	ANODO
6	REC949656	949656	ARO TÓRICO	O-RING	O-RING

DESPIECE COLA DE VELEROS  
SAILBOAT GEARCASE COMPONENTS  
ESPLOSO PIEDE VELA  
120, 130, 150, M525

NEW

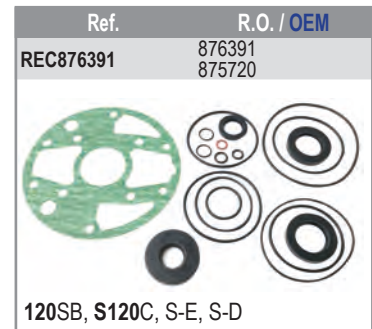
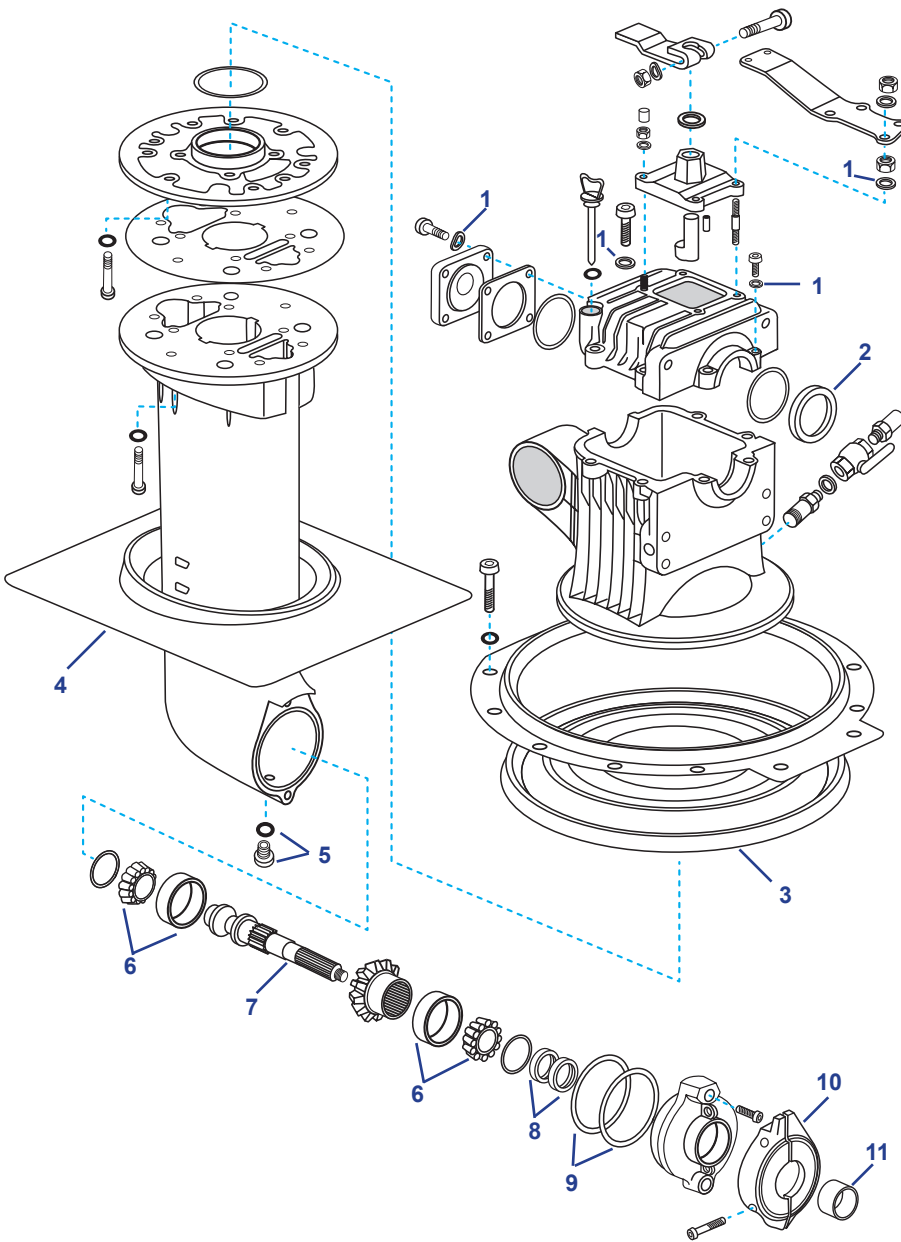

Nº	Ref.	R.O. OEM	Descripción	Description	Descrizione
1	REC941907	941907	ARANDELA	WASHER	RONDELLA
2	REC3583322	3583322	RETÉN	SEAL	TENUTA
3	REC21389074	21389074	KIT REPARACION GOMA	GOMMA REPAIR KIT	KIT RIPARAZIONE GOMMA
4	CEF501001	22303438	GOMA PASACASCOS COLA 120S	BELLOW KIT	GOMMA PASSASCAFO PIEDE 120S
5	REC22-67892A05	3854539	TAPÓN	CAP	TAPPO
6	REC31-66668A1	3854249	COJINETE RODILLO (no válido para 150)	BEARING (not valid for 150)	CUSCINETTO (non valido per 150)
7	REC3582888	3582888	ÁRBOL TRANSMISIÓN (no válido para 150)	SHAFT SAILBOAT (not valid for 150)	ALBERO (non valido per 150)
8	REC3593663	3593663	RETÉN	O-RING	TENUTA
9	REC889672	889672	ARO TÓRICO (120 y 130)	O-RING (120 & 130)	TENUTA (120 E 130)
9	REC925256	925256	ARO TÓRICO (M525)	O-RING (M525)	TENUTA (M525)
10	CM851983	876286	KIT ÁNODO DE ZINC (110, 120)	KIT ZINC ANODE (110, 120)	KIT ANODO ZINCO (110, 120)
10	CM851983A	876286	KIT ÁNODO ALUMINIO (110, 120)	KIT ALUMINIUM ANODE (110, 120)	KIT ANODO ALLUMINIO (110, 120)
10	CM3888305	3888305	KIT ÁNODO DE ZINC (130, 150)	KIT ZINC ANODE (130, 150)	KIT ANODO ZINCO (130, 150)
10	CM3888305A	3888305	KIT ÁNODO ALUMINIO (130, 150)	KIT ALUMINIUM ANODE (130, 150)	KIT ANODO ALLUMINIO (130, 150)
11	REC3582887	3582887	DISTANCIADOR EJE COLAS	SPACER SHAFT	DISTANZIATORE DELL'ASSE



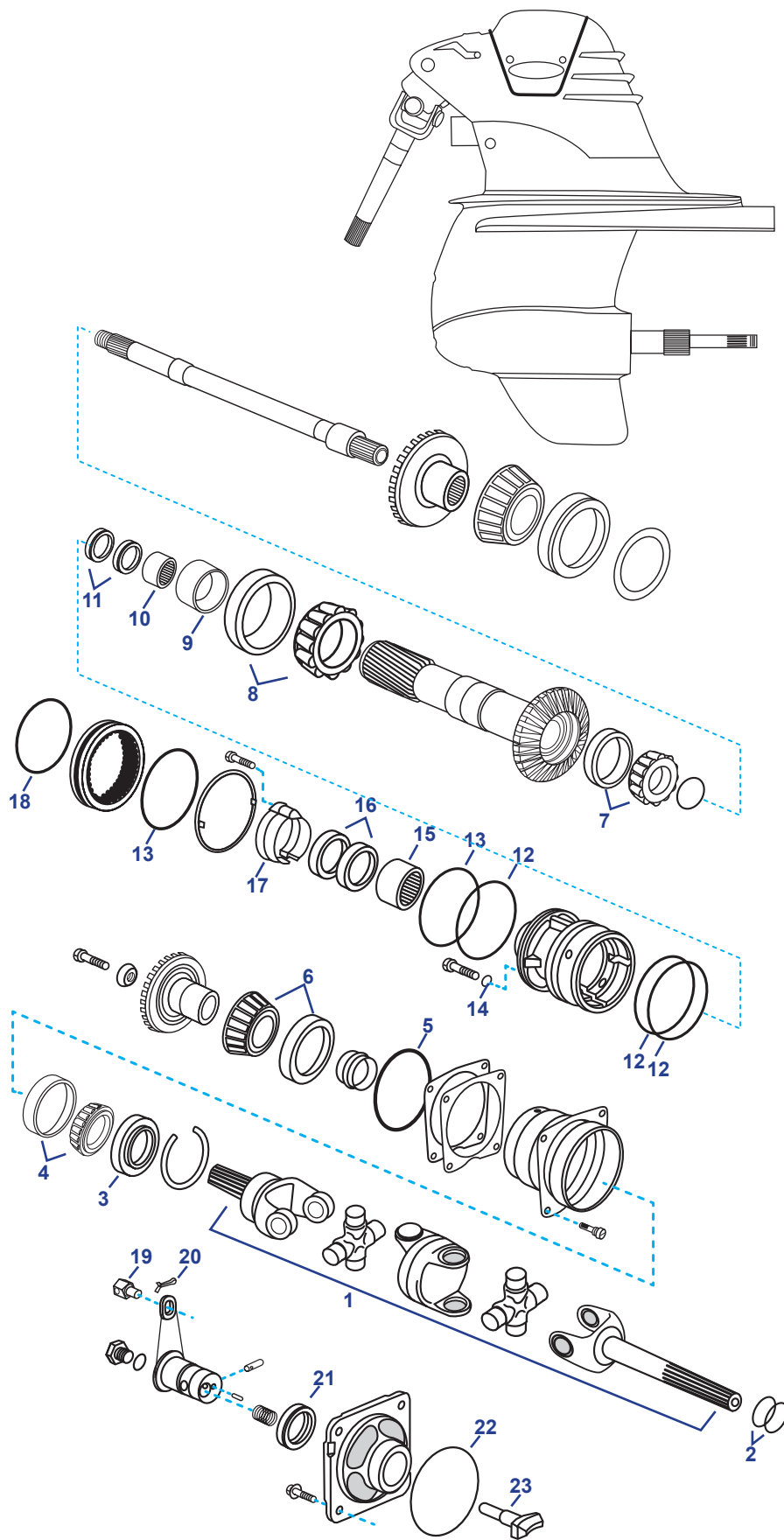
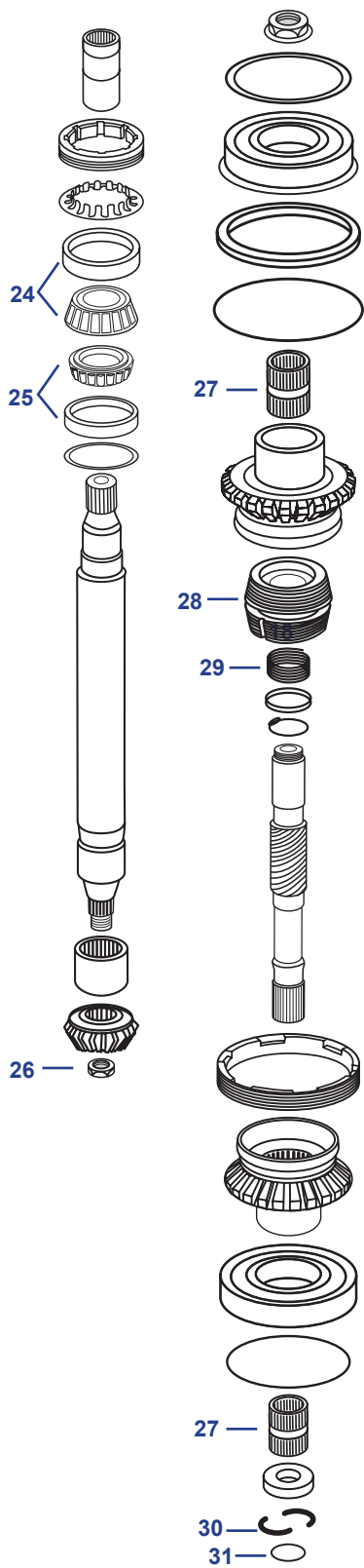

Nº	Ref.	R.O. OEM	Descripción	Description	Descrizione
1	RM3860842	3860842	TRANSMISIÓN COMPLETA	U-JOINT ASSEMBLY	KIT CARDANO
2	REC25-30613	3852565	KIT 2 ANILLOS TÓRICOS	2 O-RINGS	KIT 2 O-RING
3	REC3852272	3852272	RETÉN	SEAL	PARAOLIO
4	REC183247	3850853	COJINETE	BEARING	CUSCINETTO
5	REC967344	967344	ARO TÓRICO	O-RING	O-RING
6	REC3850852	3850852	COJINETE	BEARING	CUSCINETTO
7	RM184691	184691	COJINETE	BEARING	CUSCINETTO
8	REC184765	184765	COJINETE	BEARING	CUSCINETTO
9	REC184683	184683	ANILLO INTERIOR	RING	ANELLO INTERIORE
10	REC183272	183272	COJINETE	BEARING	CUSCINETTO
11	REC853808	853808	RETÉN	SEAL	PARAOLIO
12	REC942791	942791	ARO TÓRICO	O-RING	O-RING
13	REC946438	946438	ARO TÓRICO	O-RING	O-RING
14	REC955981	955981	ARO TÓRICO	O-RING	O-RING
15	REC183859	183859	COJINETE DE RODILLO	BEARING	CUSCINETTO
16	REC851407	851407	RETÉN	O-RING	O-RING
17	CM3861634	3861634	ÁNODO DE CINC	ZINC ANODE	ANODO IN ZINCO
17	CM3861634A	3861634	ÁNODO DE ALUMINIO	ALUMINIUM ANODE	ANODO IN ALLUMINIO
18	REC3852865	3852865	ARO TÓRICO	O-RING	O-RING
19	REC22336734	3852329	CUBO	HUB	CUBE
20	REC3854480	3854480	PASADOR HENDIDO	PIN	SPINOTTO
21	REC853868	853868	RETÉN	SEALING RING	O-RING TENUTA
22	REC925093	925093	ARO TÓRICO	O-RING	O-RING
23	RM3856502	3856502	PUNTERA SELECTOR	GEAR DOG	PERNO
24	REC31-86748A1	6854250	COJINETE RODILLO	BEARING	CUSCINETTO
25	REC31-66668A1	3854249	COJINETE RODILLO	BEARING	CUSCINETTO
26	REC852212	852212	TUERCA	NUT	DADO
27	RM3852390	3852390	COJINETE	BEARING	CUSCINETTO
28	RM3807613	3807613	MANGUITO DESLIZANTE	SLIDING SLEEVE	CONO SELETTORE
29	REC3852296	3852296	RESORTE	SPRING	MOLLA
30	REC3852295	3852295	CLIP	CLIP	CLIP
31	REC949656	949656	ARO TÓRICO	O-RING	O-RING



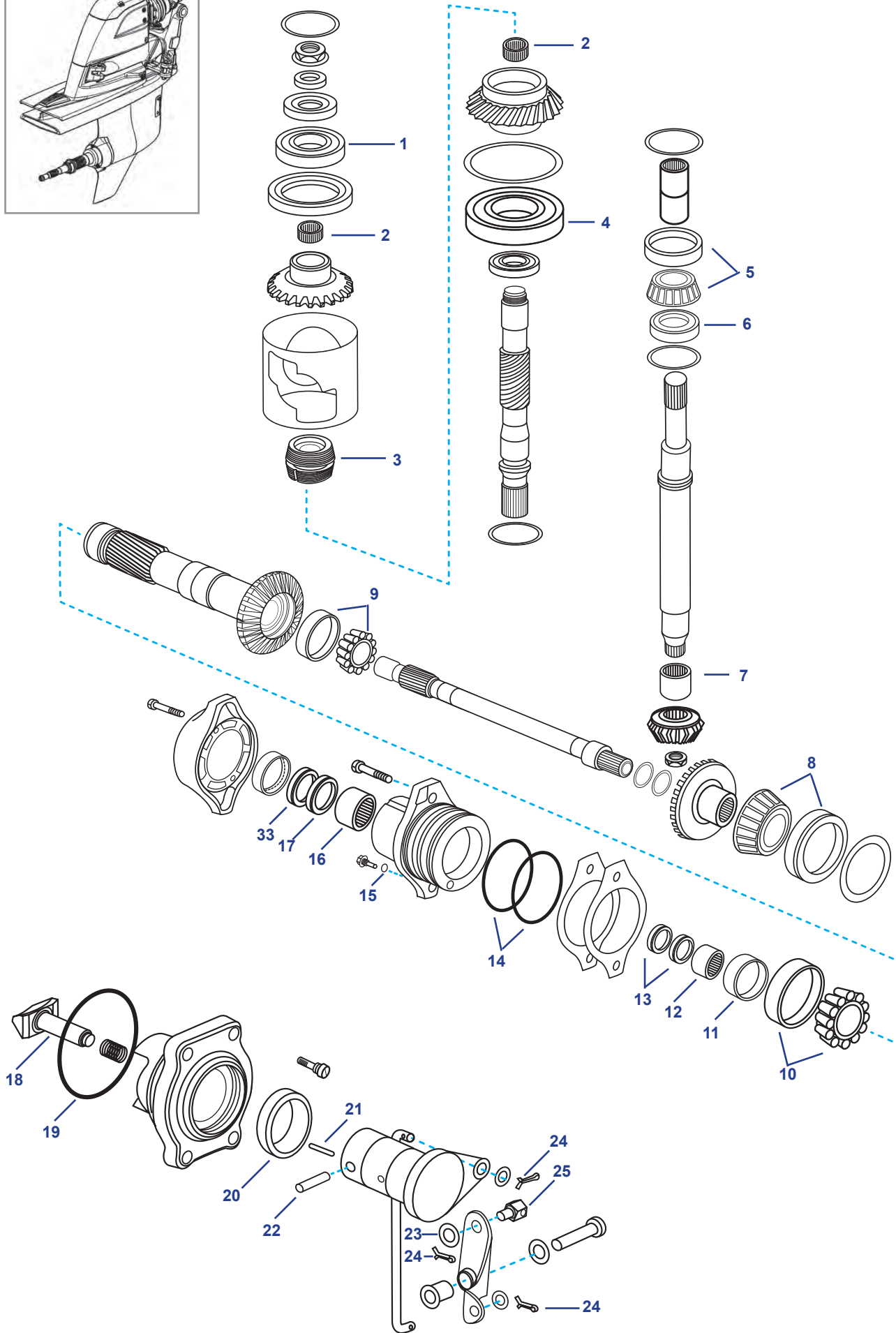
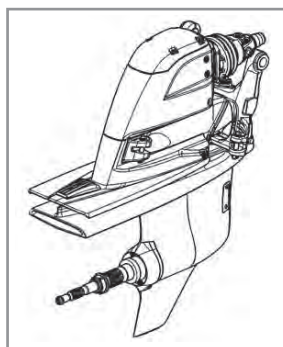

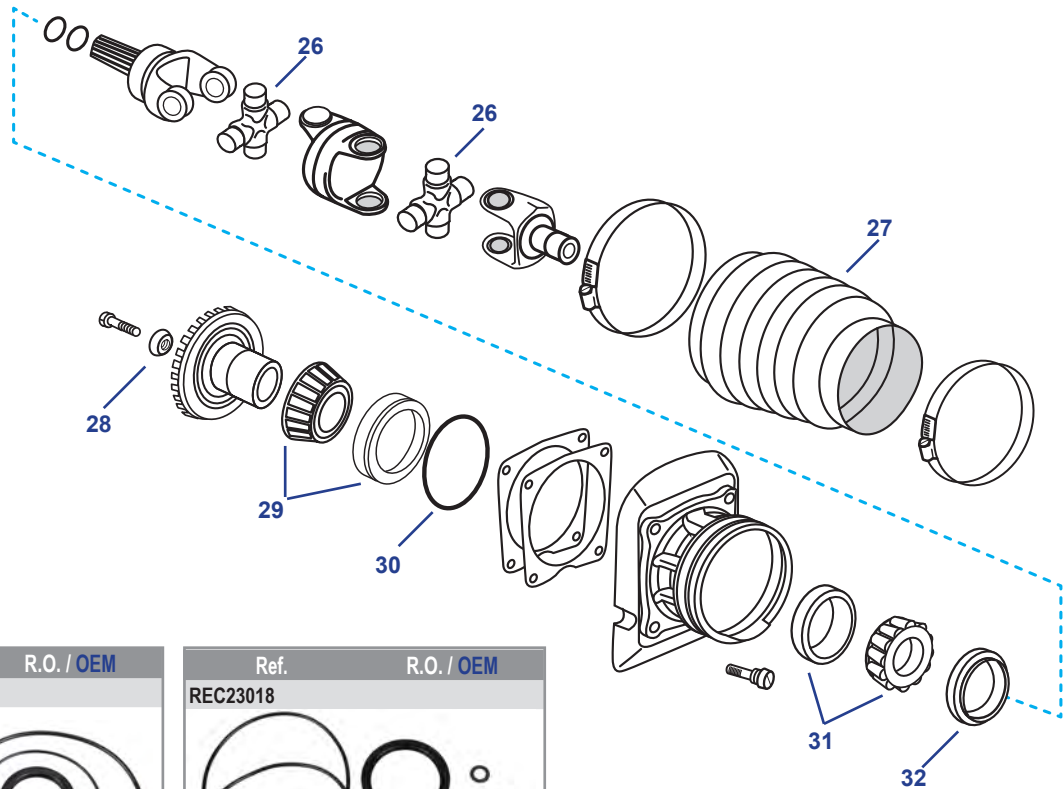

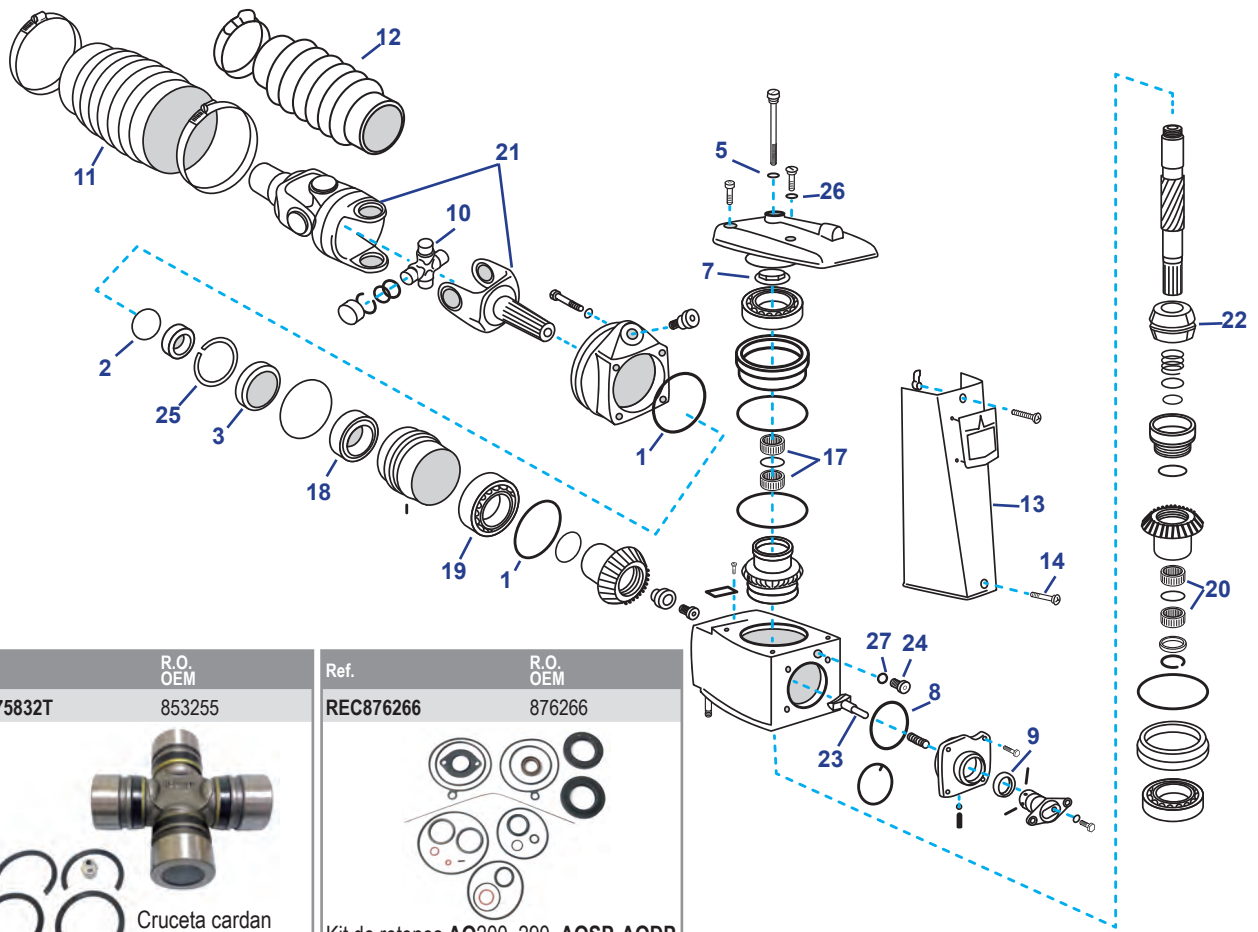

Nº	Ref.	R.O. OEM	Descripción	Description	Descrizione
1	REC181804	181804	COJINETE BOLAS	BEARING	CUSCINETTO
2	REC184778	184778	COJINETE DE RODILLO	BEARING	CUSCINETTO
3	REC3849006	3849006	MANGUITO DESLIZANTE	SLIDING SLEEVE	CONO SELETTORE
4	REC993430	993430	COJINETE DE BOLAS	BEARING	CUSCINETTO
5	REC11065	11065	COJINETE DE RODILLO	BEARING	CUSCINETTO
6	REC984223	984223	COJINETE DE BOLAS	BEARING	CUSCINETTO
7	REC184654	184654	COJINETE	BEARING	CUSCINETTO
8	REC183765	183765	COJINETE DE RODILLO	BEARING	CUSCINETTO
9	REC425784	425784	COJINETE DE RODILLO	BEARING	CUSCINETTO
10	REC984222	984222	COJINETE DE RODILLO	BEARING	CUSCINETTO
11	REC984225	984225	CASQUILLO	BUSHING	BOCCOLA
12	REC183390	184642	COJINETE	BEARING	CUSCINETTO
13	REC3863080	3863080+3863081	KIT RETENES	SEALS KIT	KIT TENUTE
14	REC925260	925260	ARO TÓRICO	O-RING	O-RING
15	REC889455	889455	JUNTA TAPÓN ACEITE	GASKET OF OIL CAP	GUARNIZIONE TAPPO OLIO
16	REC984224	984224	COJINETE AGUJAS	BEARING	CUSCINETTO
17	REC3863083	3863083	RETÉN	SEAL RING	PARAOLIO
18	REC3862387	3862387	PUNTERA SELECTOR	DOG	TERMINALE
19	REC945624	945624	ARO TÓRICO	O-RING	O-RING
20	REC3863085	3863085	RETÉN	SEAL RING	TENUTA
21	REC951936	951936	PASADOR TUBULAR	PIN	SPINOTTO
22	REC3862867	3862867	PASADOR	PIN	SPINOTTO
23	REC940191	940191	ARANDELA	WASHER	RONDELLA
24	REC17276	17276	PASADOR HENDIDO	PIN	SPINOTTO
25	REC22336734	22336734	CUBO	HUB	CUBO
26	REC3843136	3843136	CRUCETA	U-JOINT	CROCETTA
27	REC3808898	3808898	FUELLE	BELLOW	CUFFIA
28	REC3862387	3862387	ARANDELA	WASHER	RONDELLA
29	REC11096	11096	COJINETE RODILLO	BEARING	CUSCINETTO
30	REC925259	925259	ARO TÓRICO	O-RING	O-RING
31	REC11043	11043	COJINETE	BEARING	CUSCINETTO
32	REC3863084	3863084	RETÉN ACEITE	SEAL OIL	PARAOLIO
33	REC3863082	3863082	RETÉN	SEAL	TENUTA

PARTE SUPERIOR AQUAMATIC (ANTIGUA)  
UPPER HOUSING (OLD TYPE)  
PARTE SUPERIORE AQUAMATIC (MODELLO VECCHIO)



Ref.	R.O. OEM	Ref.	R.O. OEM
REC75832T	853255	REC876266	876266
 <p>Cruceta cardan Universal Joint Crocetta cardano</p>		 <p>Kit de retenes AQ200, 290, AQSP, AQDP Seal kit Kit riparazione</p>	

Nº	Ref.	R.O. OEM	Descripción	Description	Descrizione
1	REC925256	925256	ARO TÓRICO	O-RING FOR SEALING RING	O-RING
2	REC832675	832675	ARO TÓRICO (280, 290, SP, DP)	SEALING RING FOR (280, 290, SP, DP)	O-RING (280, 290, SP, DP)
3	REC839253	839253	RETÉN ACEITE (280, 290, SP, DP)	OIL SEAL FOR (280, 290, SP, DP)	PARAOLIO (280, 290, SP, DP)
3	REC942615	942615	RETÉN ACEITE (200, 250, 270)	OIL SEAL FOR (200, 250, 270)	PARAOLIO (200, 250, 270)
5	REC955974	955974	ARO VARILLA ACEITE	O-RING FOR DIPSTICK	O-RING ASTICELLA OLIO
7	REC832669	832669	JUNTA RETÉN TAPA	GASKET/SEAL FOR TOP COVER	GUARNIZIONE COPERCHIO
8	REC925093	925093	ARO	O-RING FOR SHIFT FORK HOUSING	O-RING
9	REC853868	853868	RETÉN ACEITE	OIL SEAL FOR SHIFT SHAFT	PARAOLIO
10	REC75832T	853255	CRUCETA CARDAN	U-JOINT	CROCETTA CARDANO
11	REC876294	876294	FUELLE CRUCETA	U-JOINT BELLOWS	CUFFIA CROCETTA
12	REC876633	876633	FUELLE ESCAPE CON FLAP	EXHAUST BELLOWS WITH FLAPPERS	CUFFIA SCARICO CON VALVOLA
12	REC876631	876631	FUELLE ESCAPE SIN FLAP	EXHAUST BELLOWS WITHOUT FLAPPERS	CUFFIA SCARICO SENZA VALVOLA
13	REC832570	832570	TAPA TRASERA	REAR COVER	COPERCHIO POSTERIORE
14	REC941816	941816	TORNILLO INFERIOR TAPA TRASERA	REAR COVER LOWER SCREW	VITE INFERIORE, COPERCHIO
17	REC853542	853542	COJINETE (70, 275, 280, 290, DP-A, DP-B)	BEARING (70, 275, 280, 290, DP-A, DP-B)	CUSCINETTO (70, 275, 280, 290, DP-A, DP-B)
17	REC3857176	3857176	COJINETE (SP-A1, A2, C, C1, DPA1, A2, B1, C, D, D1, E, G, DPX, S, S1, SX)	BEARING (SP-A1, A2, C, C1, DPA1, A2, B1, C, D, D1, E, G, DPX, S, S1, SX)	CUSCINETTO (SP-A1, A2, C, C1, DPA1, A2, B1, C, D, D1, E, G, DPX, S, S1, SX)
18	REC183247	183247	COJINETE	BEARING	CUSCINETTO
19	REC3850852	3850852	COJINETE	BEARING	CUSCINETTO
20	RM3852390	3852390	COJINETE	BEARING	CUSCINETTO
21	RM3860230	3860230	EJE CARDAN 27 ESTRÍAS	YOKE 27 Splines	ASSE CARDANO 27 DENTI
22	RM3807613	3807613	CONO SELECTOR	SLIDING SLEEVE	CONO SELETTORE
23	RM3856502	3856502	PUNTERA CONO SELECTOR	SLEEVE SHOE	PERNO
24	RM981965	981965	TORNILLO TAPÓN	OIL PLUG	BULLONE TAPPO
25	REC956000	956000	ARO TÓRICO	O-RING	O-RING
26	REC955989	955989	ARO TÓRICO	O-RING	O-RING
27	REC897682	897682	JUNTA	GASKET	GUARNIZIONE

PARTE SUPERIOR AQUAMATIC (MODERNA)  
UPPER HOUSING (NEW TYPE)  
PARTE SUPERIORE AQUAMATIC (MODELLO MODERNO)

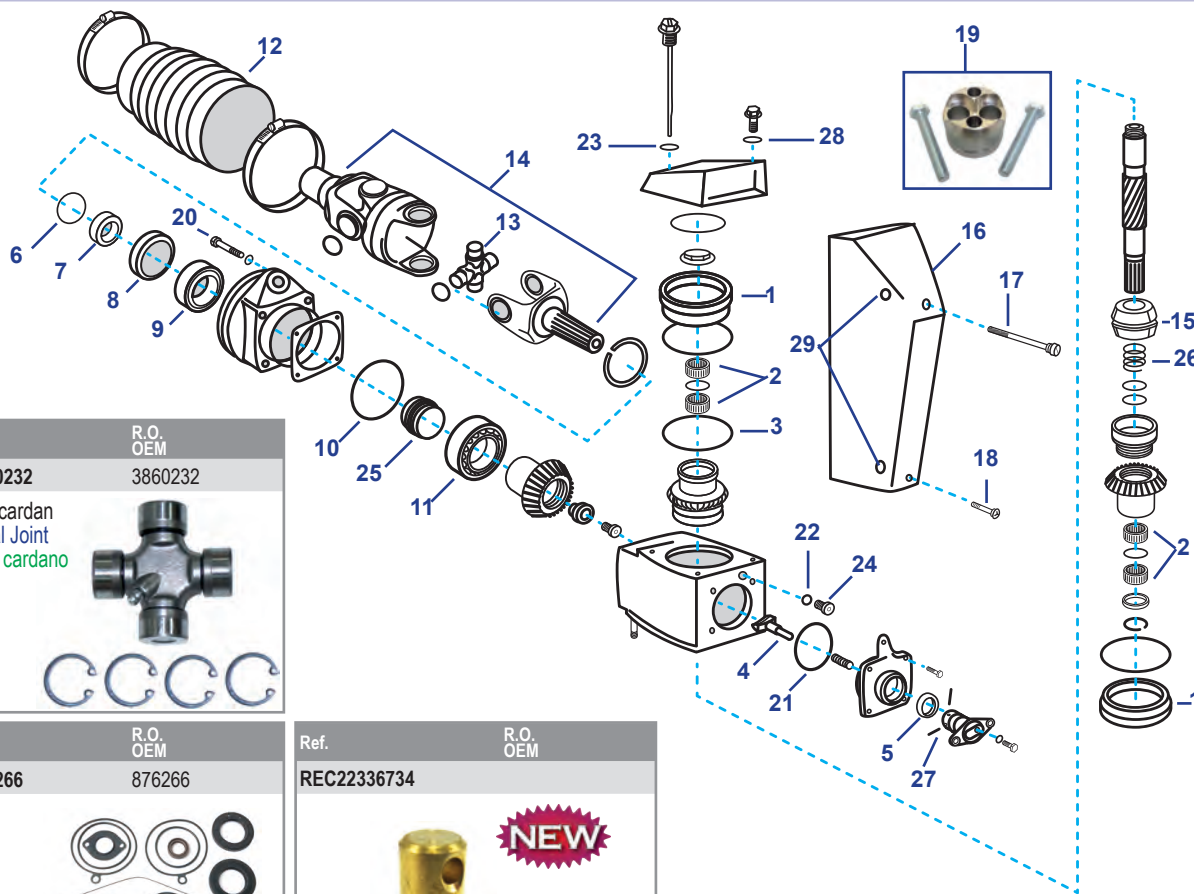

Nº	Ref.	R.O. OEM	Descripción	Description	Descrizione
1	REC3857176	3857176	COJINETE	BEARING	CUSCINETTO
2	RM3852390	3852390	COJINETE	BEARING	CUSCINETTO
3	REC832669	832669	JUN TA	GASKET	GUARNIZIONE
4	RM3856502	3856502	PUNTERA CONO SELECTOR	GEAR DOG	PERNO CONO SELETTORE
5	REC853868	853868	RETÉN	SEALING RING	PARAOLIO
6	REC956000	956000	ARO TÓRICO	O-RING	O-RING
7	REC832675	832675	ARANDELA	WASHER	RONDELLA
8	REC839253	839253	RETÉN	SEALING RING	PARAOLIO
9	REC183247	183247	COJINETE	ROLLER BEARING	CUSCINETTO
10	REC967344	967344	ARO TÓRICO	O-RING	O-RING
11	REC3850852	3850852	COJINETE	BEARING	CUSCINETTO
12	REC876294	876294	FUELLE TRANSOM	TRANSOM KIT	CUFFIA CARDANO
13	REC3860232	3860232	CRUCETA CARDAN (290)	GEAR SPIDER (290)	CROCETTA CARDANO (290)
14	RM3860230	3860230	KIT TRANSMISION (290SP, DP)	GEAR UNIVERSAL JOINT (290SP, DP)	KIT TRASMISSIONE (290SP, DP)
15	RM3807613	3807613	CONO SELECTOR	GEAR SLIDING SLEEVE	CONO SELETTORE
16	RM3857148	3857148	TAPA	COVER	COPERCHIO
17	RM872027	872027	TORNILLO	SCREW	VITE
18	RM854661	854661	TORNILLO	SCREW	VITE
19	REC852705	852705	DADO DIRECCION	PIVOT PIN	DADO
20	REC984068	984068	KIT 4 TORNILLOS (70 mm)	KIT 4 SCREWS (70 mm)	KIT 4 VITI (70 mm)
20	REC956590	956590	KIT 4 TORNILLOS (63 mm)	KIT 4 SCREWS (63 mm)	KIT 4 VITI (63 mm)
21	REC925093	925093	ARO TÓRICO	O-RING	O-RING
22	REC897682	897682	JUNTA	GASKET	GUARNIZIONE
23	REC955989	955989	ARO TÓRICO	O-RING	O-RING
24	RM981965	981965	TAPÓN	CAP	TAPPO
25	REC853484	853484	CASQUILLO	BUSHING	BOCCOLA
26	REC3852296	3852296	RESORTE	SPRING	MOLLA
27	REC951924	951924	PASADOR LEVA SELECTOR	PIN CAM SELECTOR	SPINOTTO CAMME SELETTORE
28	REC955974	955974	TÓRICA	O-RING	O-RING
29	REC925052	905052	TÓRICA	O-RING	O-RING

PARTE SUPERIOR SX  
UPPER HOUSING SX  
PARTE SUPERIORE SX

NEW

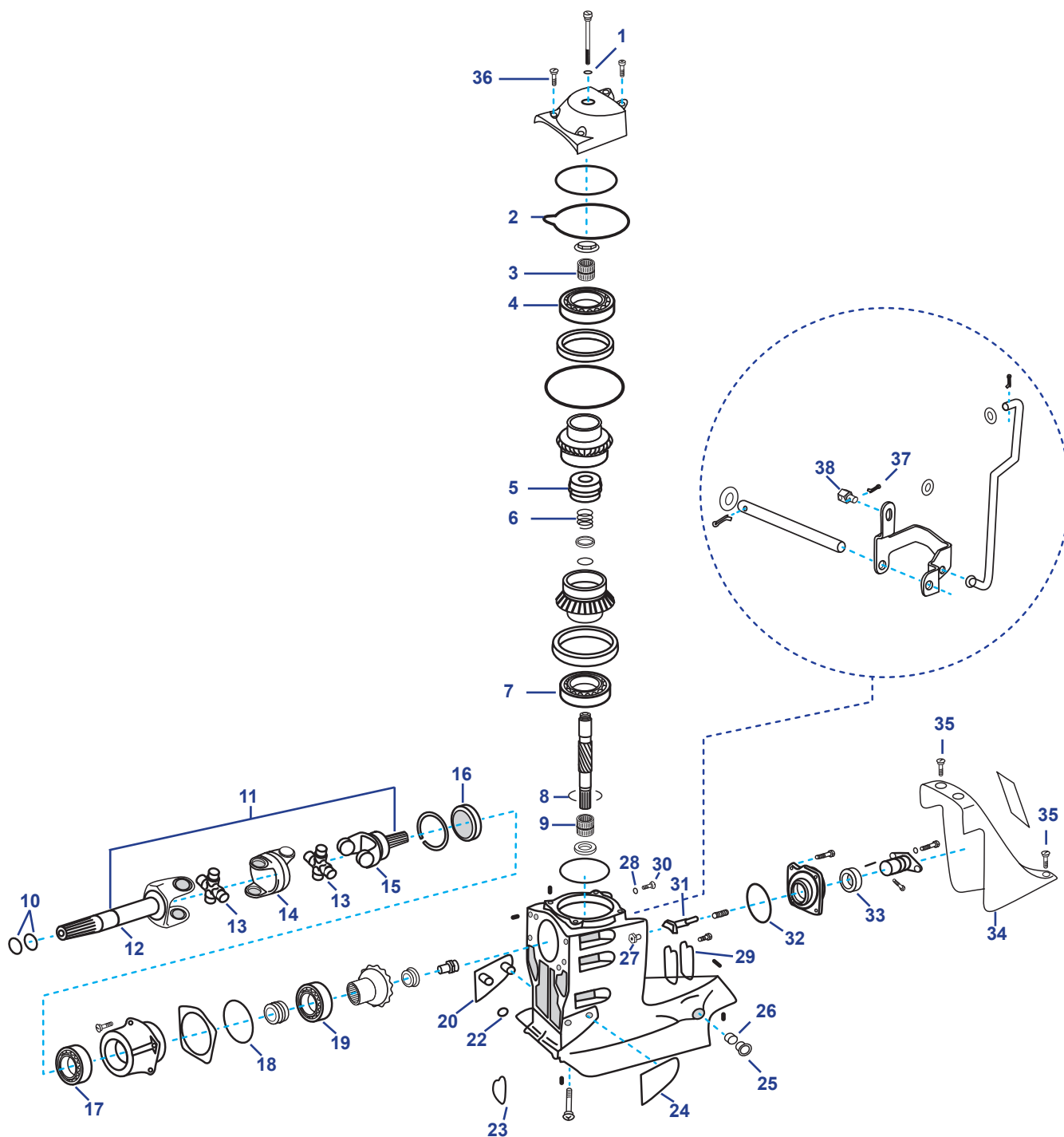

Ref.	R.O. OEM
REC3850594	3850594

Kit reparación  
Seal kit  
Kit riparazione

Ref.	R.O. OEM
REC39631	

Kit Aros Transon Sx  
Outdrive Seal Kit  
Kit Tenute Transon Sx

Nº	Ref.	R.O. OEM	Descripción	Description	Descrizione
1	REC3852045	3852045	ARO TÓRICO	O-RING	O-RING
2	REC3852317	3852317	JUNTA	GASKET	GUARNIZIONE
3	RM3852390	3852390	COJINETE	BEARING	CUSCINETTO
4	REC3857176	3857176	COJINETE	BEARING	CUSCINETTO
5	RM3807613	3807613	SELECTOR	SLIDING S	SELETTORE
6	REC3852296	3852296	RESORTE	SPRING	MOLLA
7	REC3857176	3856176	COJINETE	BEARING	CUSCINETTO
8	REC3852295	3852295	CIRCLIP	CIRCLIP	CLIP
9	RM3852390	3852390	COJINETE	BEARING	CUSCINETTO
10	REC25-30613	3852565	ARO TÓRICO	O-RING	O-RING
11	REC3860842	3860842	TRANSMISIÓN COMPLETA	U-JOINT ASSEMBLY	KIT CARDANO
11	RM3860842	3860842	TRANSMISIÓN COMPLETA (XDP-B, DP-SM, SMTD3, DPS-A, B, SX-A, M, M1, MTD)	U-JOINT ASSEMBLY (XDP-B, DP-SM, SMTD3, DPS-A, B, SX-A, M, M1, MTD)	KIT CARDANO (XDP-B, DP-SM, SMTD3, DPS-A, B, SX-A, M, M1, MTD)
12	REC59830A7	3850815	EJE LARGO CARDAN	YOKE DRIVE-SHAFT	ALBERINO CARDANO
13	REC3850812	3850812	CRUCETA CARDAN	UNIVERSAL JOINT	CROCETTA CARDANO
14	REC393831	3850813	CARDAN	SOCKET	CARDANO
15	REC3850814	3850814	EJE CORTO CARDAN	YOKE	ALBERINO CARDANO
16	REC3852272	3852272	RETÉN	OIL SEAL	PARAOLIO
17	REC183247	183247	COJINETE	BEARING	CUSCINETTO
18	REC967344	967344	ARO TÓRICO	O-RING	O-RING
19	REC3850852	3850852	COJINETE	BEARING	CUSCINETTO
20	REC3589524	3589524	TAPA ESTRIBOR	PLATE	COPERCHIO DESTRA
22	RM3852516	3852516	RETENEDOR	RETAINER	TENUTA
23	REC3852560	3852560	RETÉN	OIL SEAL	PARAOLIO
24	REC3589522	3589522	TAPA BABOR	PLATE	COPERCHIO SINISTRA
25	REC3853423	3853423	CASQUILLO	BUSHING	BOCCOLA
26	RM3853424	3853424	ARO	RING	O-RING
27	RM3852648	3852648	TUERCA	NUT	DADO
28	REC3855081	3855081	JUNTA	GASKET	GUARNIZIONE
29	REC3852279	3852279	JUNTA	GASKET	GUARNIZIONE
30	REC22-67892A05	3854539	TAPÓN	CAP	TAPPO
31	RM3856502	3856502	PUNTERA SELECTOR	DOG	TERMINALE
32	REC925093	925093	ARO TÓRICO	O-RING	O-RING
33	REC853868	853868	RETÉN	OIL SEAL	PARAOLIO
34	RM3852418	3852418	TAPA	COVER	COPERCHIO
35	REC3852568	3852568	TORNILLO	SCREW	VITE
36	REC3852454	3852454	TORNILLO	SCREW	VITE
37	REC3854480	3854480	PASADOR HENDIDO	PIN	SPINOTTO
38	REC22336734	22336734	CUBO	HUB	CUBO



PARTE SUPERIOR SX-A, FWD, DPS-A, DPS-B  
UPPER HOUSING SX-A, FWD, DPS-A, DPS-B  
PARTE SUPERIORE SX-A, FWD, DPS-A, DPS-B

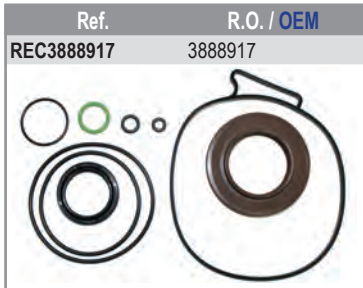
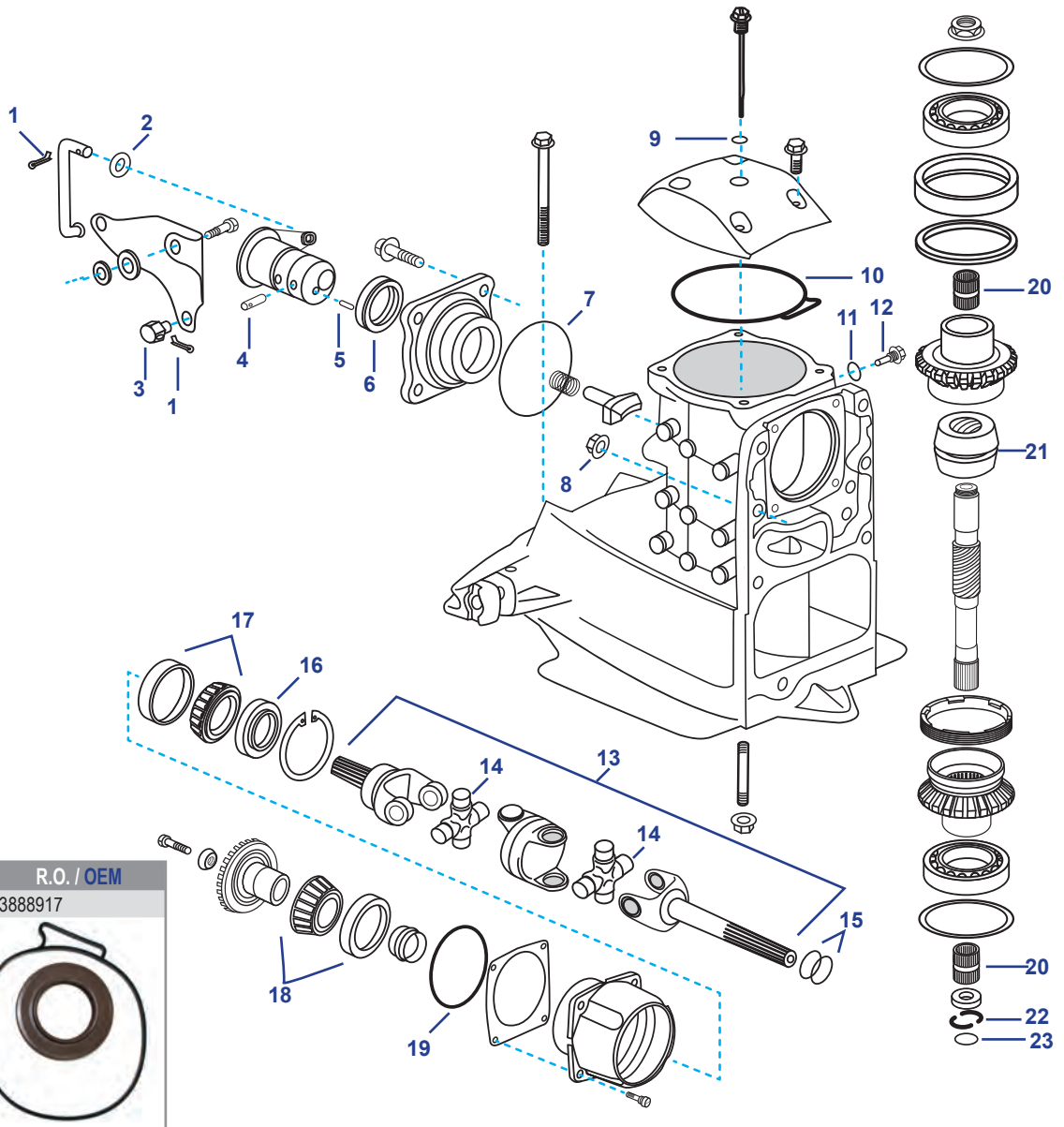

N°	Ref.	R.O. OEM	Descripción	Description	Descrizione
1	REC3854480	3854480	PASADOR HENDIDO	PIN	SPINOTTO
2	REC92995-08600	3852193	ARANDELA	WASHER	RONDELLA
3	REC22336734	22336734	CUBO	HUB	CUBO
4	REC3862867	3862867	PASADOR	PIN	SPINOTTO
5	REC951936	951936	PASADOR TUBULAR	PIN	SPINOTTO
6	REC3863085	3863085	RETÉN	SEAL RING	O-RING TENUTA
7	REC925093	925093	ARO TÓRICO	O-RING	O-RING
8	RM3852648	3852648	TUECA	NUT	DADO
9	REC3852045	3852045	ARO TÓRICO	O-RING	O-RING
10	REC3889782	3889782	JUNTA	GASKET	GUARNIZIONE
11	REC3855081	3855081	ARO TÓRICO	O-RING	O-RING
12	REC22-67892A05	3854539	TAPÓN	CAP	TAPPO
13	RM3860842	3860842	TRANSMISIÓN COMPLETA	U-JOINT ASSEMBLY	KIT CARDANO
14	REC3850812	3850812	CRUCETA	UNIVERSAL JOINT	CROCETTA CARDANO
15	REC25-30613	997368	AROS TÓRICOS	O-RINGS	O-RING
16	REC3852272	3852272	RETÉN	SEAL	TENUTA
17	REC183247	183247	COJINETE RODILLO	BEARING	CUSCINETTO
18	REC3850852	3850852	COJINETE	BEARING	CUSCINETTO
19	REC967344	967344	ARO TÓRICO	O-RING	O-RING
20	RM3852390	3852390	COJINETE	BEARING	CUSCINETTO
21	RM3807613	3807613	MANGUITO DESLIZANTE	SLIDING	SELETTORE
22	REC3852295	3852295	CLIP	CLIP	CLIP
23	REC949656	949656	ARO TÓRICO	O-RING	O-RING

**PARTE SUPERIOR DP-G, DPX-A**  
**UPPER HOUSING DP-G, DPX-A**  
**PARTE SUPERIORE DP-G, DPX-A**

**NEW**

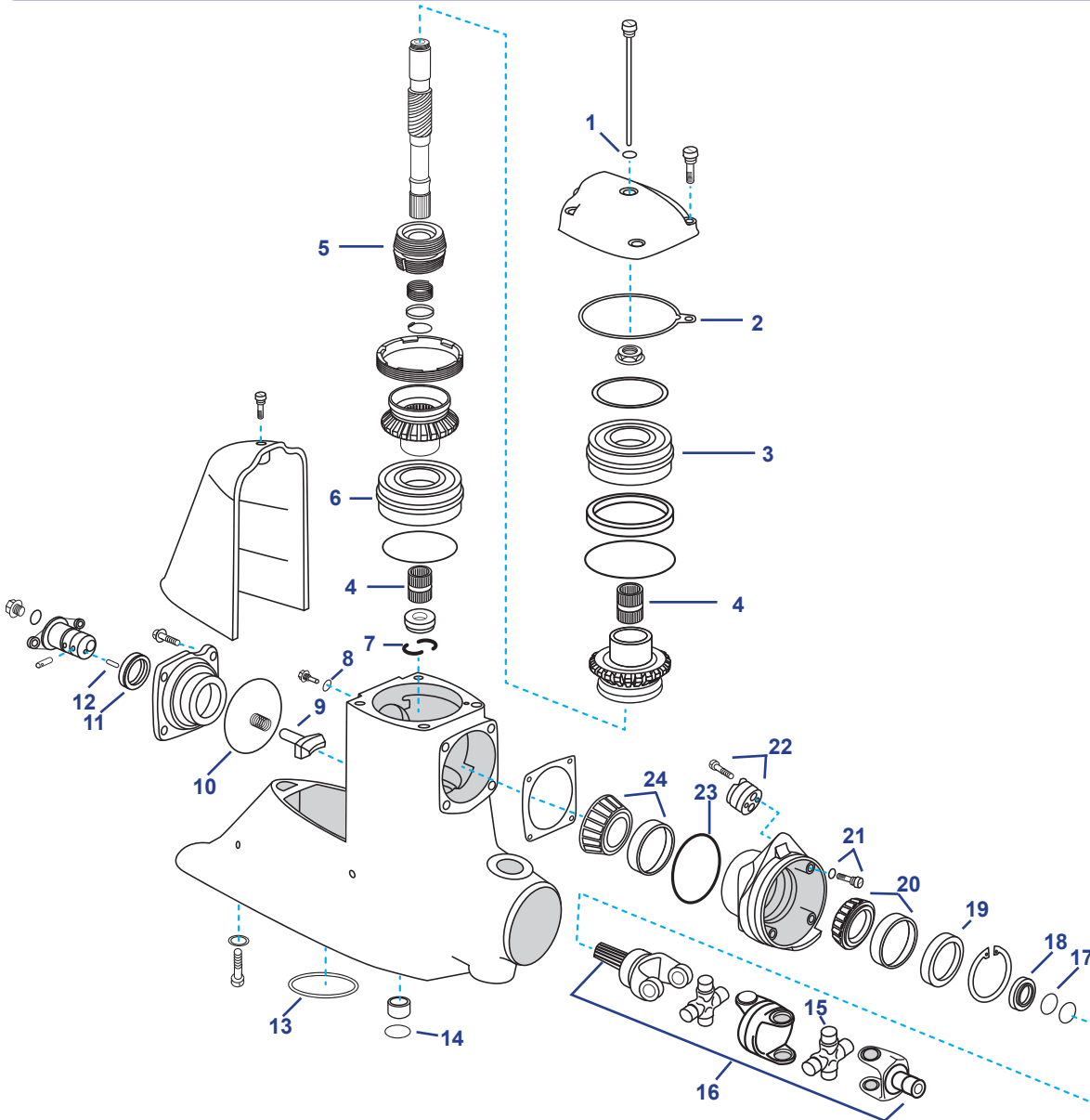

Nº	Ref.	R.O. OEM	Descripción	Description	Descrizione
1	REC3852045	3852045	ARO TÓRICO	O-RING	O-RING
2	REC3860183	3860183	JUNTA	GASKET	GUARNIZIONE
3	REC3857176	3857176	COJINETE	BEARING	CUSCINETTO
4	RM3852390	3852390	COJINETE	BEARING	CUSCINETTO
5	RM3807613	3807613	CONO SELECTOR	GEAR SLIDING SLEEVE	CONO SELETTORE
6	REC3857176	3857176	COJINETE	BEARING	CUSCINETTO
7	REC3852295	3852295	CLIP	CLIP	CLIP
8	REC3855081	3855081	JUNTA	GASKET	GUARNIZIONE
9	RM3856502	3856502	PUNTERA CONO SELECTOR	GEAR DOG	PERNO CONO SELETTORE
10	REC925093	925093	RETÉN	O-RING	O-RING
11	REC853868	853868	RETÉN	SEAL	TENUTA
12	REC973593	973593	PIN	PIN	PIN
13	REC925256	925256	ARO TÓRICO	O-RING	O-RING
14	REC125017	125017	ARO TÓRICO	O-RING	O-RING
15	REC3860232	3860232	CRUCETA CARDAN	UNIVERSAL JOINT	CROCETTA CARDANO
16	RM3860230	3860230	KIT TRANSMISION 290SP/DP	U-JOINT ASSEMBLY 290SP/DP	KIT CARDANO 290SP/DP
17	REC956000	956000	ARO TÓRICO	O-RING	O-RING
18	REC832675	832675	ARANDELA	WASHER	RONDELLA
19	REC839253	839253	RETÉN	SEAL	TENUTA
20	REC183247	183247	COJINETE	BEARING	CUSCINETTO
21	REC984068	984068	KIT TORNILLOS	SCREW KIT	KIT VITE
22	REC852705	852705	DADO DIRECCIÓN	PIVOT PIN	DADO
23	REC967344	967344	ARO TÓRICO	O-RING	O-RING
24	REC3850852	3850852	COJINETE	BEARING	CUSCINETTO

PARTE INFERIOR AQUAMATIC  
LOWER HOUSING  
PARTE INFERIORE AQUAMATIC

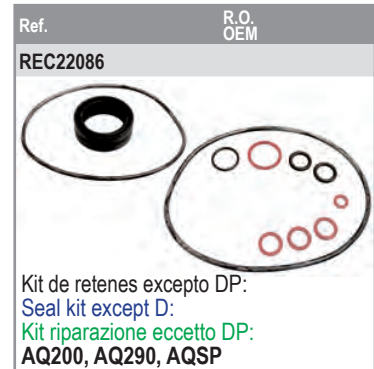
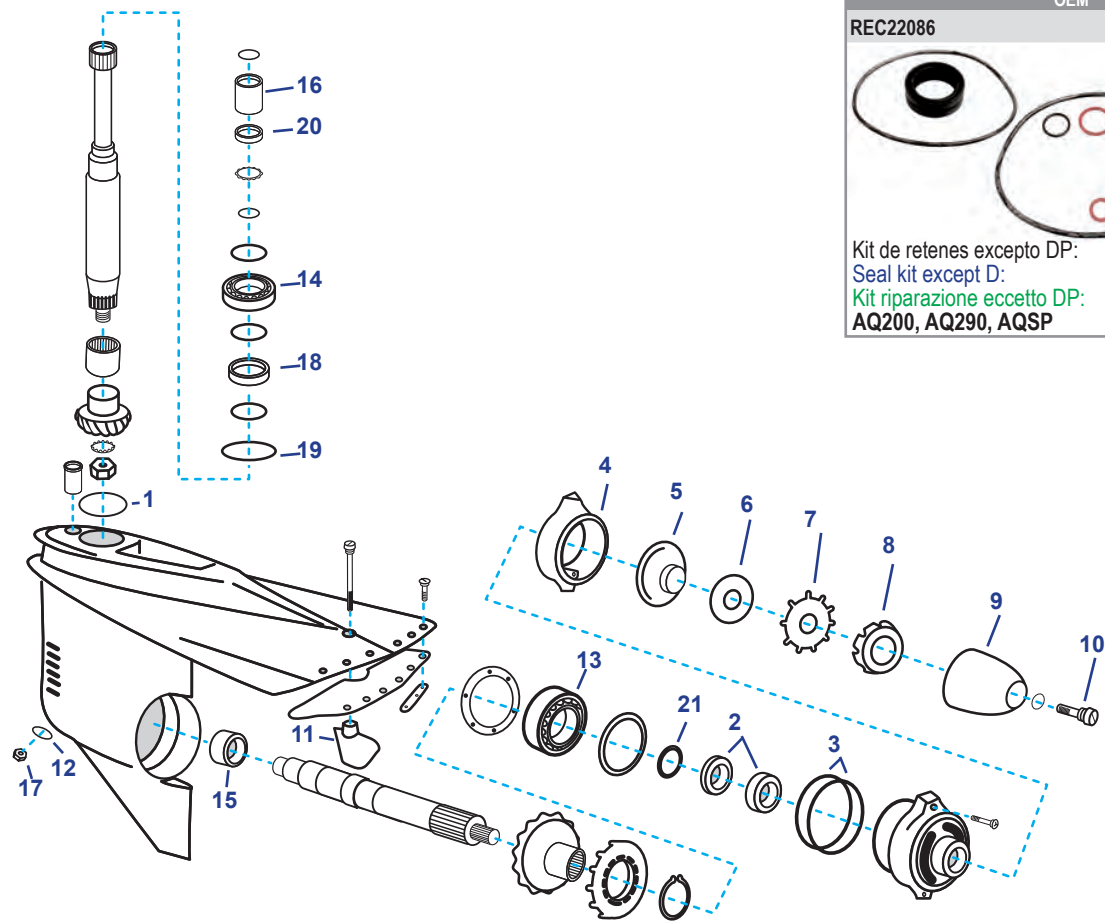

Nº	Ref.	R.O. OEM	Descripción	Description	Descrizione
1	REC925256	925256	ARO TÓRICO	O-RING	O-RING
2	REC897426	897426	RETENES EJE HELICE	PROP SHAFT SEALS	PARAOLIO ASSE ELICA
3	REC925261	925261	ARO TÓRICO	O-RING	O-RING
4	CMCMV-18	875815	ÁNODO ZINC (AQ280SP, 290SP)	ZINC ANODE (AQ280SP, 290SP)	ANODO ZINCO (AQ280SP, 290SP)
4	CMCMV-18A	875815	ÁNODO ALUMINIO (AQ280SP, 290SP)	ALUMINUM ANODE (AQ280SP, 290SP)	ANODO ALLUMINIO (AQ280SP, 290SP)
4	CMV-17	875805	ÁNODO ZINC (AQ250, 270, 275)	ZINC ANODE (AQ250, 270, 275)	ANODO ZINCO (AQ250, 270, 275)
4	CM875821	875821	ÁNODO ZINC (AQ280DP, 290DP)	ZINC ANODE (AQ280DP, 290DP)	ANODO ZINCO (AQ280DP, 290DP)
4	CM875821A	875821	ÁNODO ALUMINIO (AQ280DP, 290DP)	ALUMINUM ANODE (AQ280DP, 290DP)	ANODO ALLUMINIO (AQ280DP, 290DP)
4	CM851983	876286	ÁNODO ZINC (AQ120)	ZINC ANODE (AQ120)	ANODO ZINCO (AQ120)
5	REC839423	839423	CORTALINEAS (AQ280SP, 290SP)	LINE CUTTER (AQ280SP, 290SP)	REGGISPINTA (AQ280SP, 290SP)
5	REC872082	872082	CORTALINEAS (AQ280, 290SP)	LINE CUTTER (AQ280SP, 290SP)	REGGISPINTA (AQ280SP, 290SP)
5	REC839534	839534	CORTALINEAS (AQ250, 270, 275)	LINE CUTTER (AQ250, 270, 275)	REGGISPINTA (AQ250, 270, 275)
6	REC850888	850888	ARANDELA PLASTICO	PLASTIC WASHER	RONDELLA PLASTICA
7	REC897367	897367	ARANDELA CIERRE HELICE	PROP LOCK TAB WASHER	RONDELLA CIUSURA ELICA
8	REC854047	854047	ESPACIADOR HELICE	PROP SPACER WASHER	SPESSORE ELICA
9	REC854045	854045	CONO HÉLICE INCLUYE TORNILLO	PROP CONE NUT (INCLUDES SCREW)	CONO ELICA (VITE INCLUSA)
10	REC850889	850889	TORNILLO CONO	SCREW FOR PROP CONE NUT	VITE CONO
11	REC854040	854040	TIMÓN	TRIM FIN	TIMONE
12	REC955974	955974	ARO TÓRICO	FILL SCREW O-RING	O-RING
13	REC854541	854541	COJINETE	BEARING	CUSCINETTO
14	REC11072	11072	COJINETE	BEARING	CUSCINETTO
15	REC183390	183390	COJINETE AGUJAS	NEEDLE BEARING	CUSCINETTO A RULLI
16	RM3852268	3852268	CASQUILLO ESTRIADO	SPLINNED BUSHING	BOCCOLA
17	RM852904	852904	TAPON	PLUG	TAPPO
18	REC183374	183374	COJINETE	BEARING	CUSCINETTO
19	REC832191	832191	JUNTA	GASKET	GUARNIZIONE
20	REC969071	969071	TUERCA	NUT	DADO
21	REC969073	969073	TUERCA	NUT	DADO

**PARTE INFERIOR AQUAMATIC DP  
LOWER HOUSING  
PARTE INFERIORE AQUAMATIC DP**

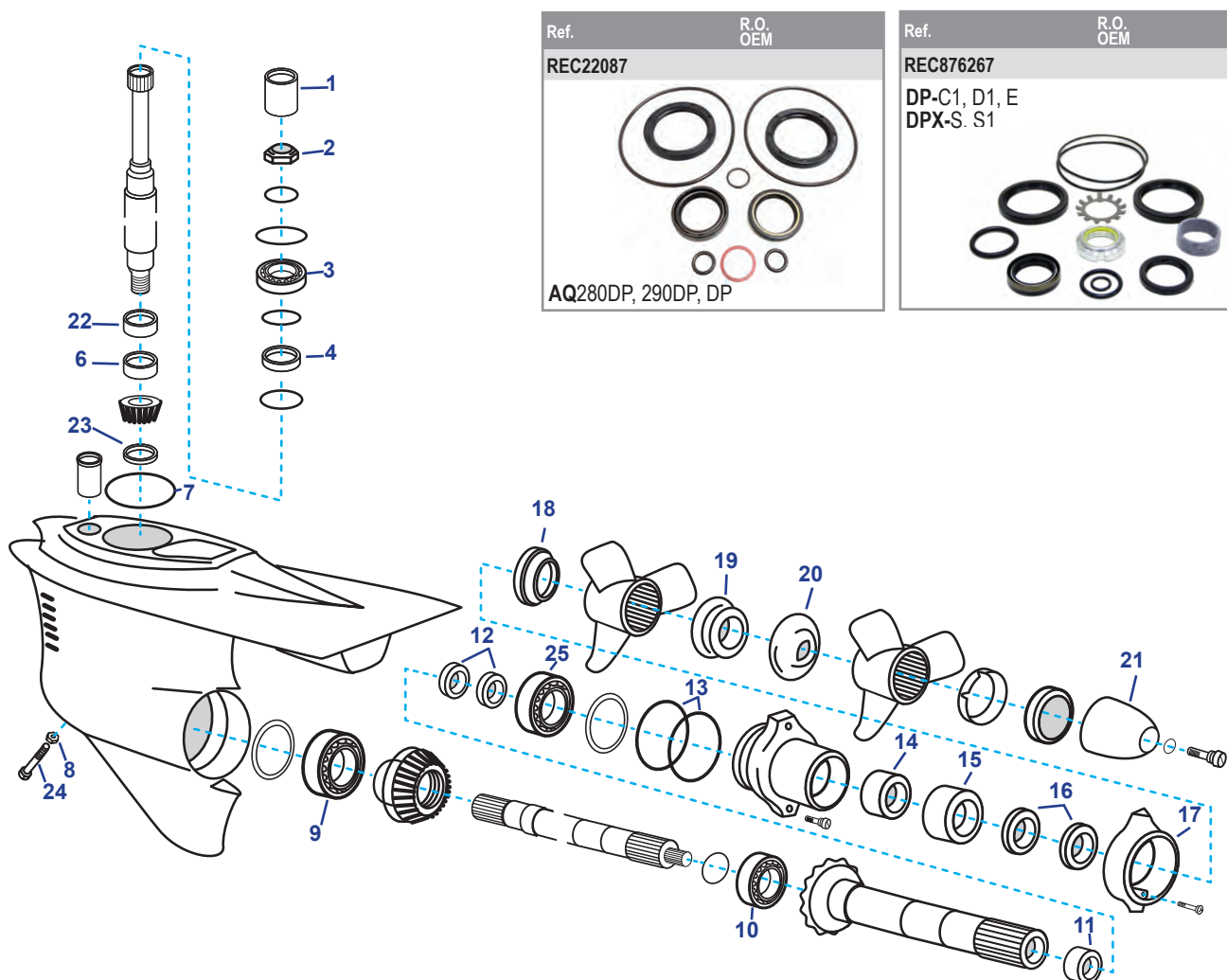

Nº	Ref.	R.O. OEM	Descripción	Description	Descrizione
1	RM3852268	3852268	MANGUITO ESTRIADO	SPLINED SLEEVE	MANICOTTO SCANALATO
2	REC969071	969071	TUERCA REDONDA	ROUND NUT	DADO
3	REC11072	11072	COJINETE	ROLLER BEARING	CUSCINETTO
4	REC183374	183374	COJINETE	BALL BEARING	CUSCINETTO
6	REC184654	184654	COJINETE AGUJAS	NEEDLE ROLLER BEARING	CUSCINETTO A RULLI
7	REC925256	925256	ARO TÓRICO	O-RING	O-RING
8	REC955974	955974	ARO TÓRICO	O-RING	O-RING
9	REC11044	11044	COJINETE	ROLLER BEARING	CUSCINETTO
10	RM184691	184691	COJINETE	ROLLER BEARING	CUSCINETTO
11	REC183272	183272	COJINETE AGUJAS	NEEDLE ROLLER BEARING	CUSCINETTO A RULLI
12	REC22087		KIT RETENES Y AROS EJE HELICE	SEALING RING KIT	KIT TENUTE & ANELLI ASSE ELICA
13	REC925258	925258	KIT RETENES EJE HELICE	O-RING	KIT PAROLIO
14	REC184683	184683	ARO INTERIOR	RING	O-RING INTERNO
15	REC183859	183859	COJINETE	NEEDLE ROLLER BUSHING	CUSCINETTO
16	REC851407	851407	RETEN EJE HELICE	SEALING RING	PARAOLIO ASSE ELICA
17	CM875821	875821	ÁNODO DE ZINC	ZINC ANODE	ANODO DI ZINCO
17	CM875821A	875821	ÁNODO DE ALUMINIO	ALUMINUM ANODE	ANODO DI ALLUMINIO
18	REC3858457	3858457	CORTALINEAS FRONTAL	THRUST RING, FRONT	O-RING REGGISPINTA FRONTALE
19	RM3851334	3851334	TUERCA HELICE	PROPELLER NUT	DADO ELICA
20	REC3858458	3858458	CORTALINEAS TRASERO	THRUST RING, REAR	O-RING REGGISPINTA POSTERIORE
21	RM872549	872549	KIT TUERCA HELICE Ø 20 mm.	PROPELLER CONE Ø 20 mm	KIT ELICA Ø 20 mm
21	RM872614	872614	KIT TUERCA HELICE Ø 16 mm.	PROPELLER CONE Ø 16 mm	KIT ELICA Ø 16 mm
22	REC184682	184682	ARO INTERIOR	RING	O-RING INTERNO
23	REC852212	852212	TUERCA	NUT	DADO
24	RM852904	852904	TAPÓN	CAP	TAPPO
25	REC184765	184765	COJINETE RODILLO	ROLLER BEARING	CUSCINETTO A RULLI

**PARTE INFERIOR SX  
LOWER HOUSING SX  
PARTE INFERIORE SX**

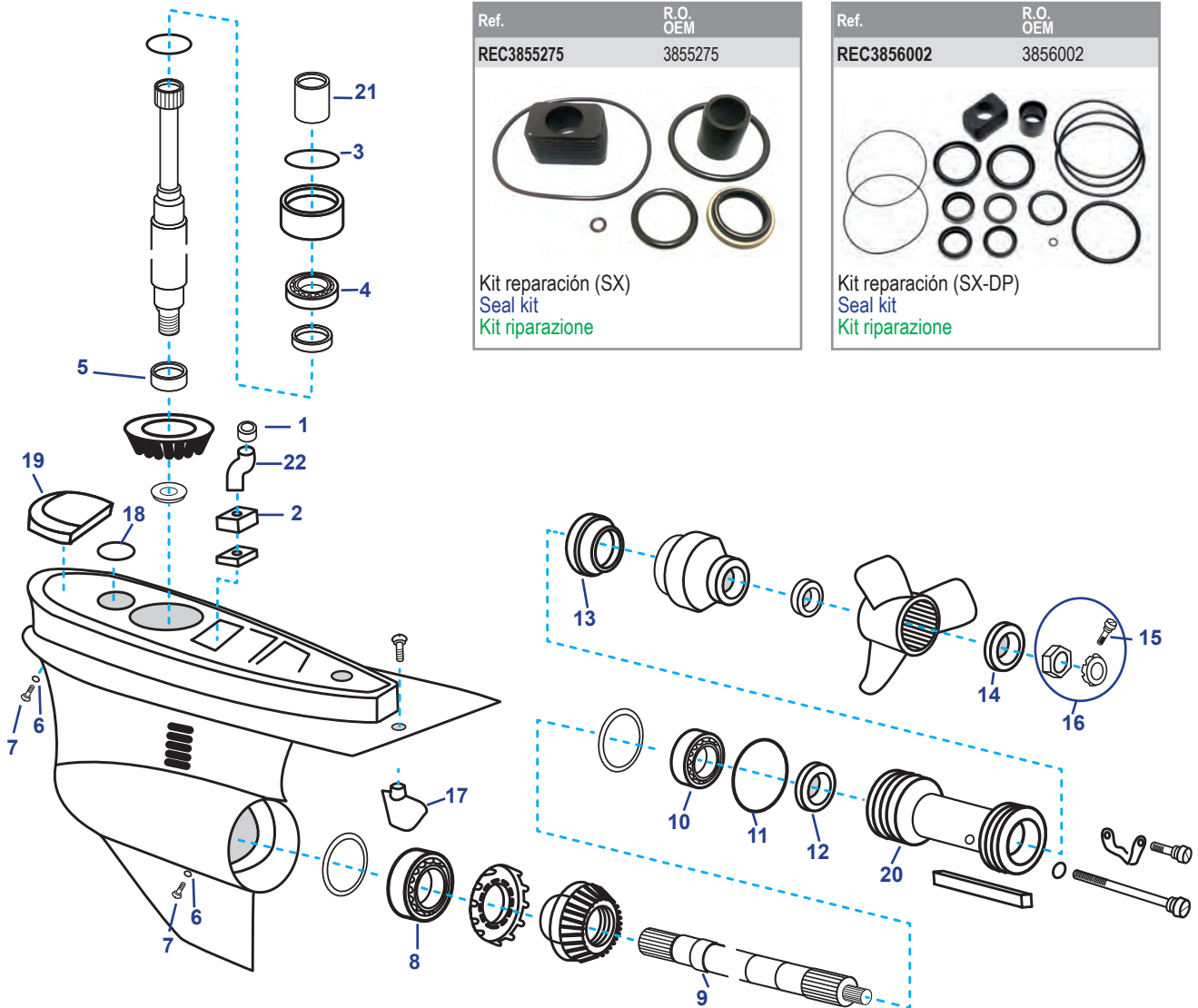

Ref.	R.O. OEM
REC3855275	3855275

Kit reparación (SX)  
Seal kit  
Kit riparazione

Ref.	R.O. OEM
REC3856002	3856002

Kit reparación (SX-DP)  
Seal kit  
Kit riparazione

Nº	Ref.	R.O. OEM	Descripción	Description	Descrizione
1	REC3852315	3852315	CASQUILLO GOMA	RUBBER INSERT	BOCCOLA IN GOMMA
2	REC3854595	3854595	RETÉN	SEAL	PARAOLIO
3	REC3852866	3852866	ARO TÓRICO	WASHER	O-RING
4	REC31-86748A1	3854250	COJINETE	BEARING	CUSCINETTO
5	REC3853934	3853934	COJINETE	BEARING	CUSCINETTO
6	REC3855081	3855081	ARANDELA	WASHER	RONDELLA
7	REC22-67892A05	3854539	TORNILLO	SCREW	VITE
8	REC3850942	3850942	COJINETE	BEARING	CUSCINETTO
9	REC3857675	3857675	EJE HÉLICE	PROP SHAFT	ASSE ELICA
10	REC31-66668A1	3854249	COJINETE	BEARING	CUSCINETTO
11	REC3852865	3852865	ARO TÓRICO	WASHER	RONDELLA
12	REC3863090	3863090	RETÉN	SEAL	TENUTA
13	REC126870	3852020	CIERRE HÉLICE	THRUST WASHER	CHIUSURA ELICA
14	REC3852350	3852350	TOPE HÉLICE	SPACER	SPESSORE
15	REC3852056	3852056	PASADOR	PIN	COPPIGLIA
16	REC398042	3850984	KIT TUERCA HÉLICE	PROP & NUT KEEPER	KIT DADO ELICA
17	REC854040	854040	TIMÓN	TRIM TAB	TIMONE
18	REC3852959	3852959	ARO TÓRICO	O-RING	O-RING
19	CM3855411	3855411	ANODO	ANODE	ANODO
19	CM3855411A	3855411	ÁNODO ALUMINIO	ANODE ALLUMINIUM	ANODO ALLUMINIO
20	RM3858051	3858051	DIÁBOLO	HOUSING BEARING	DIABOLO
21	RM3852268	3852268	CASQUILLO	BUSHING	BOCCOLA
22	RM3860252	3860252	TUBO DE AGUA	WATER TUBE	TUBO DELL'ACQUA

**PARTE INFERIOR DP-S**  
**LOWER HOUSING DP-S**  
**PARTE INFERIORE DP-S**

**NEW**

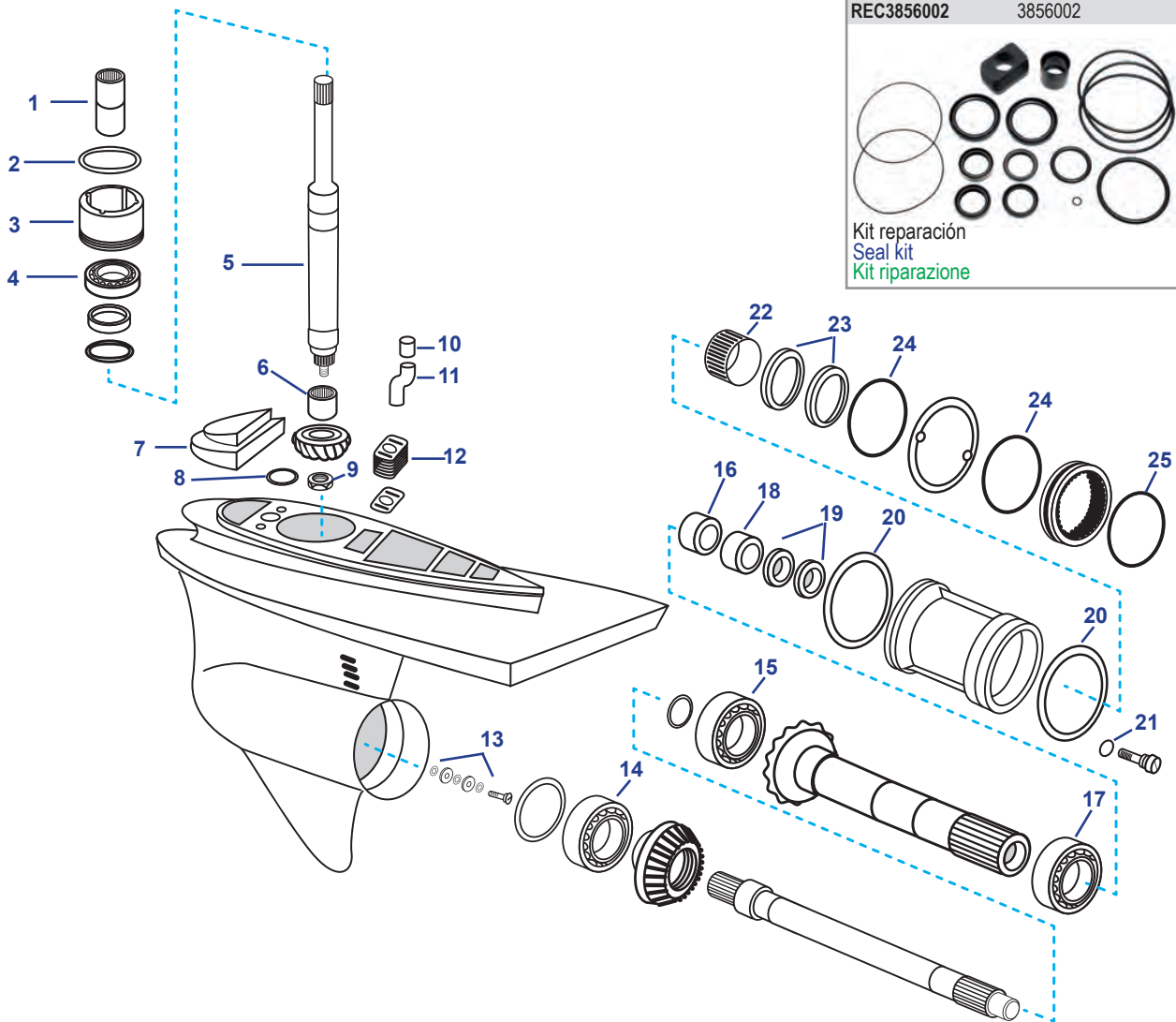

Ref.	R.O. / OEM
REC3856002	3856002

Kit reparación  
 Seal kit  
 Kit riparazione

Nº	Ref.	R.O. OEM	Descripción	Description	Descrizione
1	RM3852268	3852268	CASQUILLO ESTRIADO	SPLINED SLEEVE	CAPPUCCIO
2	REC3852866	3852866	ARO TÓRICO	O-RING	O-RING
3	REC31-86748A1	3854250	COJINETE RODILLO	BEARING	CUSCINETTO
4	REC31-66668A1	3854249	COJINETE	BEARING	CUSCINETTO
5	REC184682	184682	ANILLO INTERIOR	RING	O-RING
6	REC184654	184654	COJINETE DE RODILLO	BEARING	CUSCINETTO
7	CM3855411	3855411	ÁNODO DE CINC	ZINC ANODE	ANODO IN ZINCO
7	CM3855411A	3855411	ÁNODO DE ALUMINIO	ALUMINIUM ANODE	ANODO IN ALLUMINIO
8	REC3852959	3852959	ARO TÓRICO	O-RING	O-RING
9	REC852212	852212	TUERCA	NUT	DADO
10	REC3852315	3852315	CASQUILLO GOMA	RUBBER SEAL	PARAOLIO IN GOMMA
11	RM3860252	3860252	TUBO	PIPE	TUBO
12	REC3854595	3854595	RETÉN	SEAL	TENUTA
13	REC955893	955893	ARANDELAS	WASHERS	RONDELLE
14	REC11044	11044	COJINETE DE RODILLO	BEARING	CUSCINETTO
15	RM184691	194691	COJINETE DE RODILLO	BEARING	CUSCINETTO
16	REC184683	184683	ANILLO INTERIOR	RING	O-RING
17	REC184765	184765	COJINETE DE RODILLO	BEARING	CUSCINETTO
18	REC183272	183272	COJINETE DE RODILLO	BEARING	CUSCINETTO
19	REC853808	853808	RETÉN	SEALING RING	O-RING TENUTA
20	REC3854625	3854625	ARO TÓRICO	O-RING	O-RING
21	REC955981	955981	ARO TÓRICO	O-RING	O-RING
22	REC183859	183859	COJINETE DE RODILLO	BEARING	CUSCINETTO
23	REC851407	851407	RETÉN	SEALING RING	O-RING TENUTA
24	REC946438	946438	ARO TÓRICO	O-RING	O-RING
25	REC3854624	3854624	ARO TÓRICO	O-RING	O-RING

PARTE INFERIOR DP-SM  
LOWER HOUSING DP-SM  
PARTE INFERIORE DP-SM

NEW

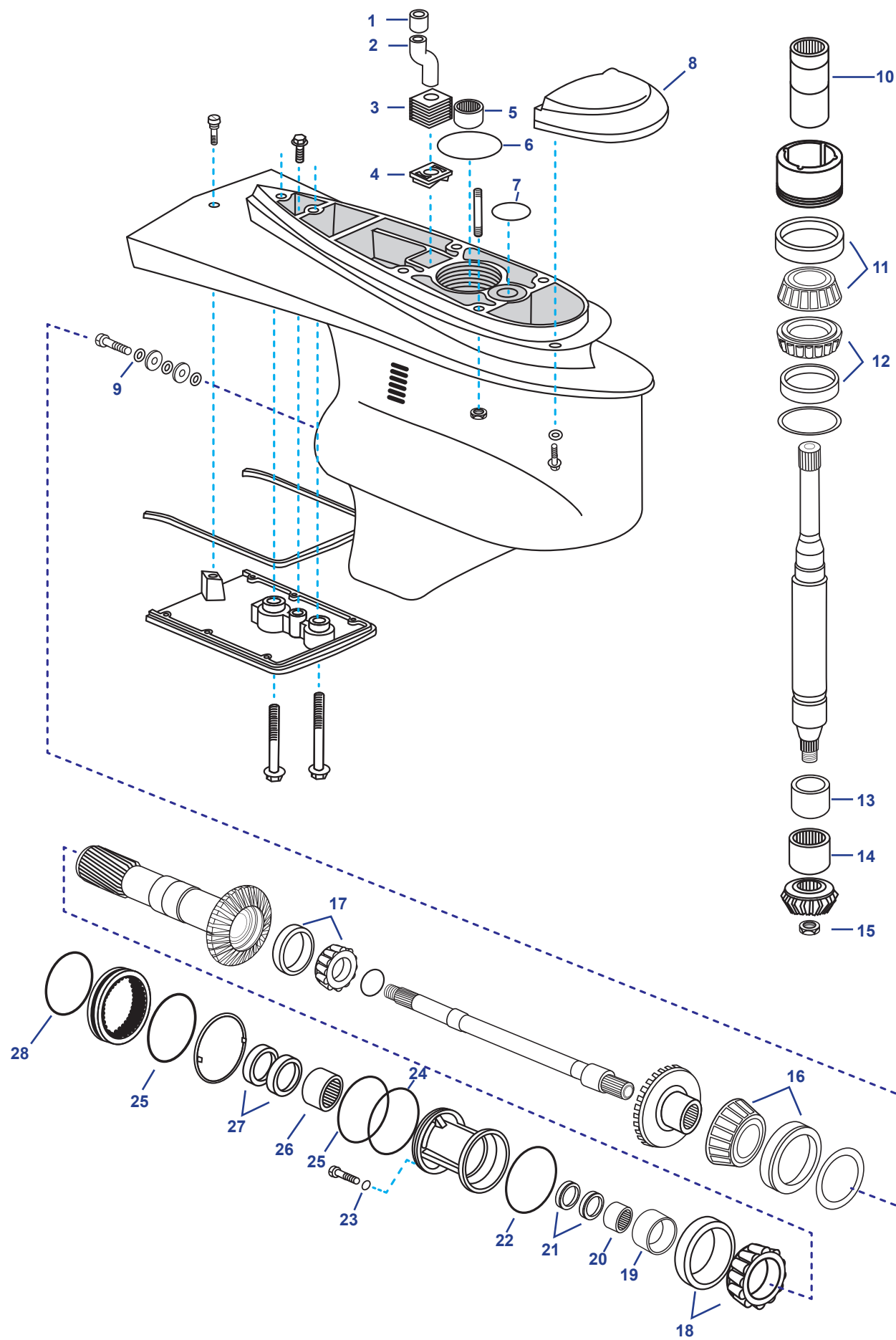

Nº	Ref.	R.O. OEM	Descripción	Description	Descrizione
1	REC3852315	3852315	CASQUILLO GOMA	RUBBER INSERT	GHIERA GOMMA
2	RM3860252	3860252	TUBO	PIPE	TUBO
3	REC3854595	3854595	RETÉN	SEAL	PARAOLIO
4	REC3854601	3854601	SOPORTE TUBO AGUA	RETAINER	SUPPORTO TUBO ACQUA
5	REC184654	184654	COJINETE	NEEDLE BEARING	CUSCINETTO
6	REC3852866	3852866	ARO TÓRICO	O-RING	FASCIA TONDA
7	REC3852959	3852959	ARO TÓRICO	O-RING	FASCIA TONDA
8	CM3855411	3855411	ÁNODO ZINC	ZINC ANODE	ANODO ZINCO
8	CM3855411A	3855411	ÁNODO ALUMINIO	ALUMINIUM ANODE	ANODO ALLUMINIO
9	REC955893	955893	ARANDELA	WASHER	RONDELLA
10	RM3852268	3852268	CASQUILLO ESTRIADO	SPLINED SLEEVE	CAPPUCCIO
11	REC31-86748A1	183512	COJINETE DE RODILLO	BEARING	CUSCINETTO
12	REC31-66668A1	3854249	COJINETE DE RODILLO	BEARING	CUSCINETTO
13	REC184682	184682	ANILLO INTERIOR	CONE	O-RING INTERNO
14	REC184654	184654	CASQUILLO RODILLO	BUSHING	BOCCOLA
15	REC852212	852212	TUERCA	NUT	DADO
16	REC11044	11044	COJINETE DE RODILLO	BEARING	CUSCINETTO
17	RM184691	184691	COJINETE DE RODILLO	BEARING	CUSCINETTO
18	REC184765	184765	COJINETE DE RODILLO	BEARING	CUSCINETTO
19	REC184683	184683	ANILLO INTERIOR	CONE	O-RING INTERNO
20	REC183272	183272	COJINETE DE RODILLO	BEARING	CUSCINETTO
21	REC853808	853807+853808	KIT RETÉN	KIT SEAL	KIT TENUTA
22	REC3854625	3854625	ARO TÓRICO	O-RING	O-RING
23	REC955981	955981	ARO TÓRICO	O-RING	O-RING
24	REC3854625	3854625	ARO TÓRICO	O-RING	O-RING
25	REC946438	946438	RETÉN	SEAL RING	O-RING TENUTA
26	REC183859	183859	COJINETE DE RODILLO	BEARING	CUSCINETTO
27	REC851407	851407	RETÉN	SEAL RING	O-RING TENUTA
28	REC3854624	3854624	ARO TÓRICO	O-RING	O-RING





**PARTE INFERIOR DPS-A, DPS-B  
LOWER HOUSING DPS-A, DPS-B  
PARTE INFERIORE DPS-A, DPS-B**

**NEW**

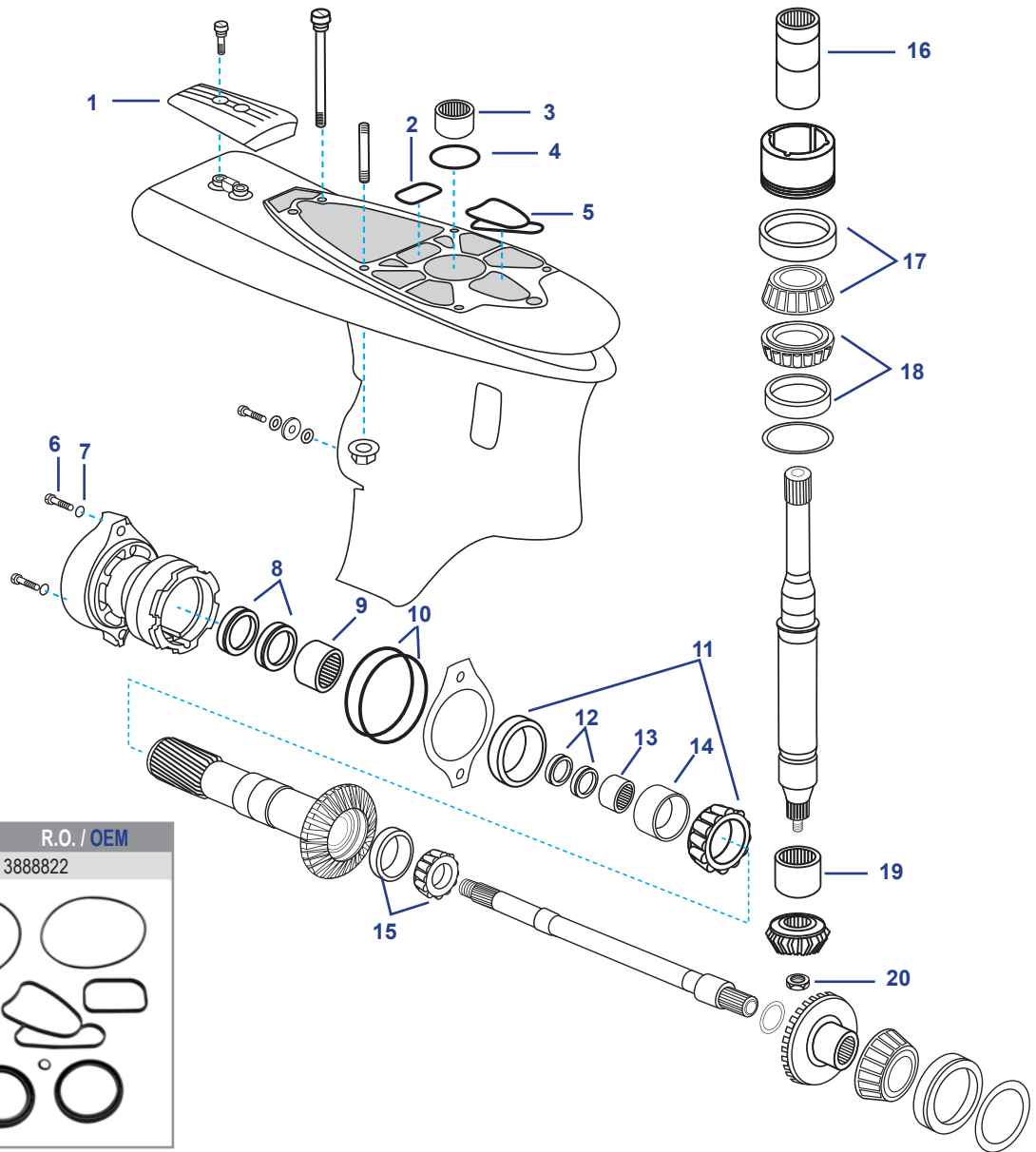

Ref.	R.O. / OEM
REC23020	3888822

Kit reparación  
Seal kit  
Kit riparazione

Nº	Ref.	R.O. OEM	Descripción	Description	Descrizione
1	CM3883728	3888814	KIT ÁNODOS ZINC	ANODES ZINC SET	KIT ANODI ZINCO
1	CM3883728A	3888813	KIT ÁNODOS ALUMINIO	ANODES ALUMINIUM SET	KIT ANODI ALLUMINIO
2	REC3889786	3889786	JUNTA	GASKET	GUARNIZIONE
3	REC184654	184654	CASQUILLO DE RODILLO	BUSHING	BOCCOLA
4	REC3852866	3852866	ARO TÓRICO	O-RING	O-RING
5	REC3889784	3889784	JUNTA	GASKET	GUARNIZIONE
6	REC22-67892A05	3854539	TORNILLO CON RETÉN CIERRE	DRAINING SCREW SET	VITE CON PARAOLIO CHIUSURA
7	REC3855081	3855081	JUNTA	GASKET	GUARNIZIONE
8	REC851407	851407	RETÉN EJE HÉLICE	SEAL	PARAOLIO ASSE ELICA
9	REC183859	183859	COJINETE	BEARING	CUSCINETTO
10	REC925259	925259	ARO TÓRICO	O-RING	O-RING
11	REC184765	184765	COJINETE COLA	ROLLER BEARING	CUSCINETTO PIEDE
12	REC853808	853808 853807	RETENES EJE HÉLICE INTERIOR	SEAL RING PROPELLER SHAFT SET	PARAOLIO ASSE ELICA
13	REC183272	183272	COJINETE DE AGUJAS	NEEDLE BEARING	CUSCINETTO
14	REC184683	184683	ARO INTERIOR	CONE	O-RING INTERNO
15	RM184691	184691	COJINETE	BEARING	CUSCINETTO
16	RM3852268	3852268	CASQUILLO ESTRIADO	SPLINED SLEEVE	CAPPUCCIO
17	REC31-86748A1	3854250	COJINETE RODILLO	ROLLER BEARING	CUSCINETTO
18	REC31-66668A1	3854249	COJINETE RODILLO	ROLLER BEARING	CUSCINETTO
19	REC184654	184654	COJINETE	BEARING	CUSCINETTO
20	REC852212	852212	TUERCA	NUT	DADO

PARTE INFERIOR SX-A  
LOWER HOUSING SX-A  
PARTE INFERIORE SX-A

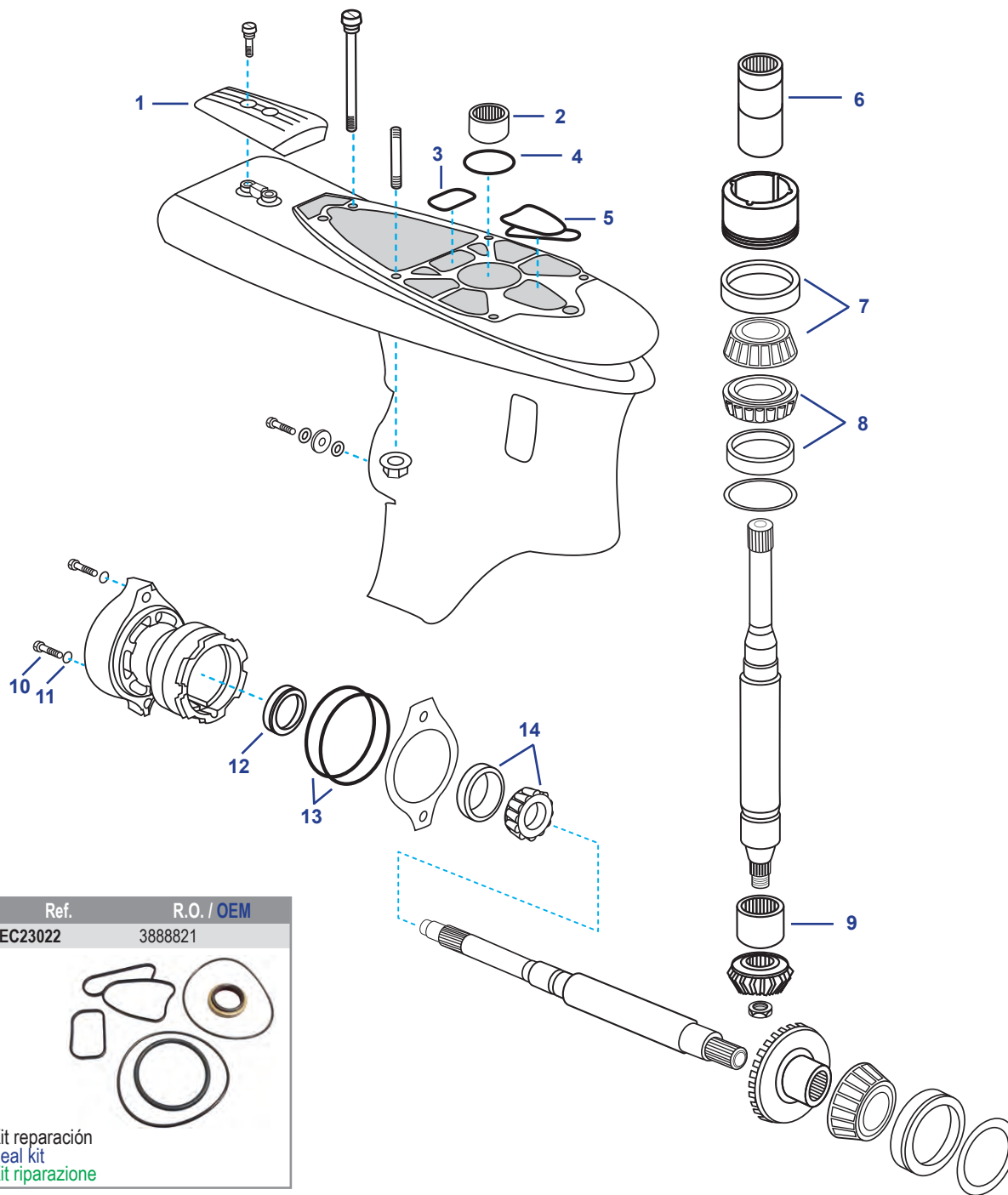

Ref.	R.O. / OEM
REC23022	3888821

Kit reparación  
Seal kit  
Kit riparazione

Nº	Ref.	R.O. / OEM	Descripción	Description	Descrizione
1	CM3883728	3842607	ÁNODO DE ZINC	ZINC ANODE	ANODO ZINCO
1	CM3883728A	3842607	ÁNODO DE ALUMINIO	ALUMINIUM ANODE	ANODO ALLUMINIO
2	REC3853934	3853934	COJINETE	BEARING	CUSCINETTO
3	REC3889786	3889786	JUNTA	GASKET	GUARNIZIONE
4	REC3852866	3852866	ARO TÓRICO	O-RING	O-RING
5	REC3889784	3889784	JUNTA	GASKET	GUARNIZIONE
6	RM3852268	3852268	MANGUITO ESTRIADO	STRAIGHTED SLEEVE	MANICOTTO SCANALATO
7	REC31-86748A1	3854250	COJINETE DE RODILLO	BEARING	CUSCINETTO
8	REC31-66668A1	3854249	COJINETE DE RODILLO	BEARING	CUSCINETTO
9	REC3853934	3853934	COJINETE	BEARING	CUSCINETTO
10	REC22-67892A05	3854539	TORNILLO	SCREW	VITE
11	REC3855081	3855081	ARO TÓRICO	O-RING	O-RING
12	REC3863090	3863090	RETÉN	SEAL	TENUTA
13	REC925259	925259	ARO TÓRICO	O-RING	O-RING
14	REC3854249	3854249	COJINETE DE RODILLO	BEARING	CUSCINETTO

PARTE INFERIOR FWD  
LOWER HOUSING FWD  
PARTE INFERIORE FWD

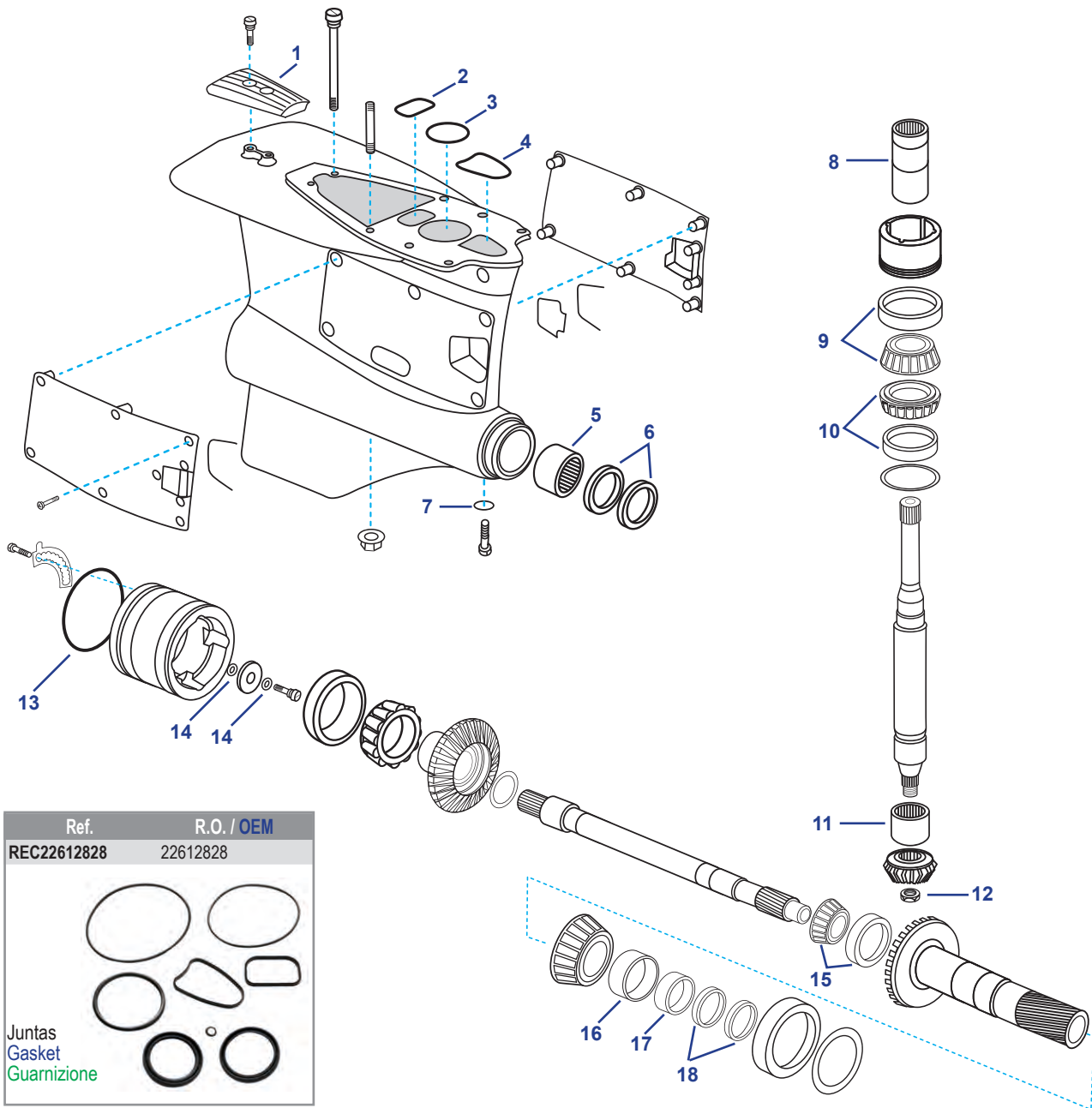

Ref.	R.O. / OEM
REC22612828	22612828

Juntas  
Gasket  
Guarnizione

Nº	Ref.	R.O. OEM	Descripción	Description	Descrizione
1	CM3883728	3888814	ÁNODO DE ZINC	ZINC ANODE	ANODO ZINCO
1	CM3883728A	3888813	ÁNODO DE ALUMINIO	ALUMINIUM ANODE	ANODO ALLUMINIO
2	REC3889786	3889786	JUNTA	GASKET	GUARNIZIONE
3	REC3852866	3852866	ARO TÓRICO	O-RING	O-RING
4	REC22430456	22430456	JUNTA	GASKET	GUARNIZIONE
5	REC183859	183959	COJINETE DE RODILLO	BUSHING	BOCCOLA
6	REC851407	851407	RETÉN	SEAL RING	O-RING TENUTA
7	REC3855081	3855081	ARO TÓRICO	O-RING	O-RING
8	RM3852268	3852268	CASQUILLO ESTRIADO	SPLINED SLEEVE	CAPPUCCIO
9	REC31-86748A1	3854250	COJINETE RODILLO	BEARING	CUSCINETTO
10	REC31-66668A1	3854249	COJINETE RODILLO	BEARING	CUSCINETTO
11	REC184654	184654	COJINETE	BEARING	CUSCINETTO
12	REC852212	852212	TUERCA	NUT	DADO
13	REC925259	925259	ARO TÓRICO	RUBER O-RING	FASCIA TONDA
14	REC955893	955893	ARANDELA	WASHER	RONDELLA
15	RM184691	184691	COJINETE RODILLO	BEARING	CUSCINETTO
16	REC184683	184683	ARO INTERIOR	O-RING	O-RING INTERNO
17	REC183272	183272	COJINETE DE RODILLO	BEARING	CUSCINETTO
18	REC853808	853808	RETÉN	SEAL RING	ANELLO TENUTA

**PARTE INTERMEDIA AQUAMATIC**  
**INTERMEDIATE HOUSING**  
**PARTE INTERMEDIA AQUAMATIC**

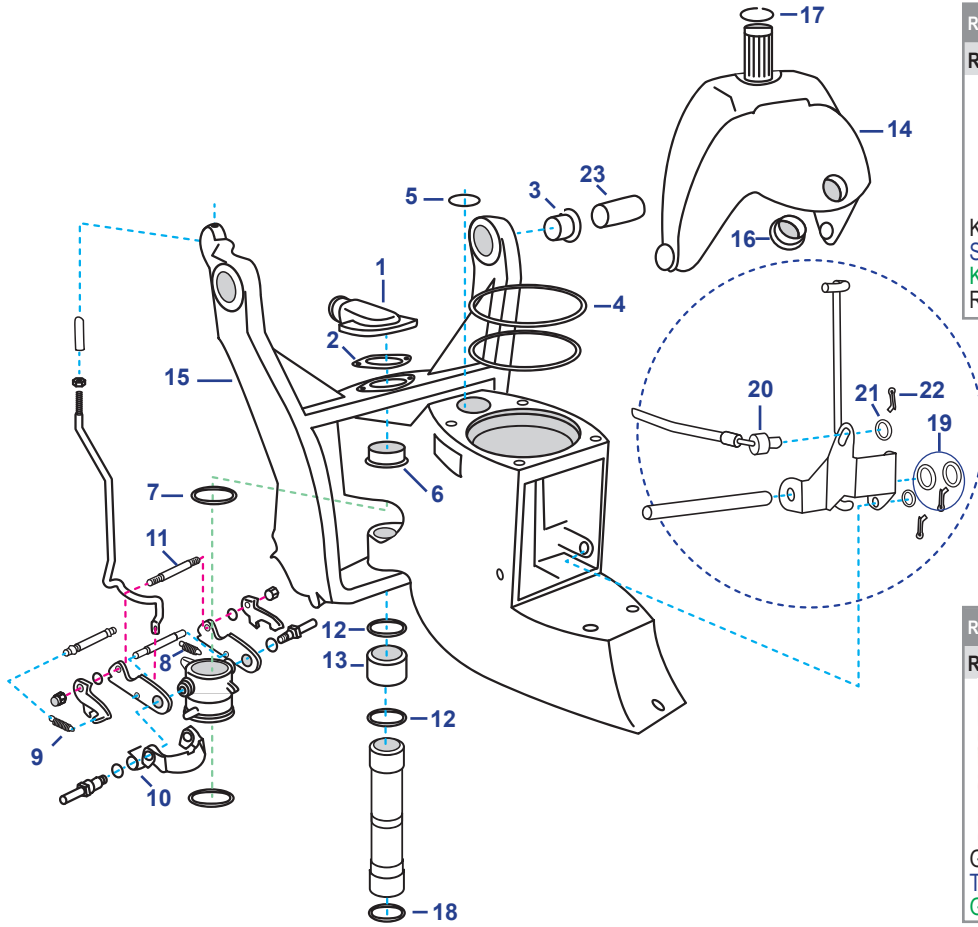

	Ref.	R.O. OEM	Descripción	Description	Descrizione
1	REC832846	851452	PIPETA TOMA AGUA (AQ270T, 280T) CON POWER TRIM	WATER OUTLET (AQ270T, 280T) WITH POWER TRIM	PIPETTA PRESACQUA (AQ270T, 280T) CON POWER TRIM
1	REC832846	854031	PIPETA TOMA AGUA (AQ200, 280) CON TILT Y AQ290	WATER OUTLET (AQ200, 280) WITH ELECTRIC TILT & (AQ290)	PIPETTA PRESACQUA (AQ200, 280) CON TILT E (AQ290)
1	REC872752	872752	PIPETA TOMA AGUA PLÁSTICO (DP, DPD, DPE, DPG, DPH, DPX)	WATER OUTLET-PLASTIC (DP, DPD, DPE, DPG, DPH, DPX)	PIPETTA PRESACQUA IN PLASTICA (DP, DPD, DPE, DPG, DPH, DPX)
2	REC814356	814356	JUNTA PIPETA	GASKET-WATER OUTLET	GUARNIZIONE PIPETTA
3	REC876278	826341	CASQUILLOS HORQUILLA (AQ) CON TILT ELÉCTRICO	TILT BUSHINGS (AQ) WITH ELECTRIC TILT	BOCCOLA FORCELLA (AQ) CON TILT ELETTRICO
3	REC832820	832820	CASQUILLOS HORQUILLA (AQ270T, 280T) CON POWER TRIM	TILT BUSHINGS (AQ270T, 280T) WITH POWER TRIM	BOCCOLA FORCELLA (AQ270T, 280T) CON POWER TRIM
3	REC876279	853223	CASQUILLOS HORQUILLA (AQ290)	TILT BUSHINGS (AQ290)	BOCCOLA FORCELLA (AQ290)
3	REC872096	872096	CASQUILLOS HORQUILLA (DP, DPD, DPE, DPG, DPH, DPX)	TILT BUSHINGS (DP, DPD, DPE, DPG, DPH, DPX)	BOCCOLA FORCELLA (DP, DPD, DPE, DPG, DPH, DPX)
4	REC925259	925259	ARO TÓRICO	O-RING	O-RING
5	REC125017	125017	ARO TÓRICO	O-RING	O-RING
6	REC814388	814388	ARO TUBO AGUA (AQ250, 270, 280)	SWIVEL BUSHING WATER PIPE (AQ250, 270, 280)	O-RING TUBO ACQUA (AQ250, 270, 280)
7	REC814390	814390	ARANDELA PLÁSTICO	PLASTIC WASHER	RONDELLA PLASTICA
8	REC832534	832534	MUELLE	SPRING REVERSE LOCK	MOLLA
9	REC814332	814332	MUELLE	SPRING REVERSE LOCK	MOLLA
10	REC814396	814396	MUELLE	SPRING REVERSE LOCK	MOLLA
11	REC814419	814419	EJE	SHAFT REVERSE LOCK	ASSE
12	REC181620	181620	RETÉN	SEAL	PARAOLIO
13	REC183391	183391	COJINETE	BEARING	CUSCINETTO
14	RM873183	873183	HORQUILLA COLA	FORK	KIT FORCELLA PIEDE
15	RM854100	854100	HORQUILLA COLA (SP-A, A1, A2, DP-A, A1, A2, 290A, B1, DA2)	FORK (SP-A, A1, A2, DP-A, A1, A2, 290A, B1, DA2)	KIT FORCELLA PIEDE (SP-A, A1, A2, DP-A, A1, A2, 290A, B1, DA2)
16	REC853048	853048	CASQUILLO	BUSHING	BOCCOLA
17	REC839195	839195	RETEN BIELA DIRECCION (Horquilla estriada)	RING (Spline)	PARAOLIO BIELLA STERZO (Forcella filettata)
17	RM977313	977313	RETEN BIELA DIRECCION (Horquilla cuadrada)	RING (Square)	PARAOLIO BIELLA STERZO (Forcella quadrata)
18	REC941820	941820	ARO TÓRICO	O-RING	O-RING
19	REC17253	17253	KIT PASADOR + ARANDELA	KIT PIN + WASHER	KIT PIN + RONDELLA
20	REC22336734	22336734	CUBO	HUB	CUBO
21	REC940191	940191	ARANDELA	WASHER	RONDELLA
22	REC17276	17276	PIN	PIN	SPINOTTO
23	REC853175	853175	BULÓN	PIN	BULLONE

**PARTE INTERMEDIA DP-E, DP-G, DP-C, DP-D**  
**INTERMEDIATE HOUSING DP-E, DP-G, DP-C, DP-D**  
**PARTE INTERMEDIA DP-E, DP-G, DP-C, DP-D**

**NEW**

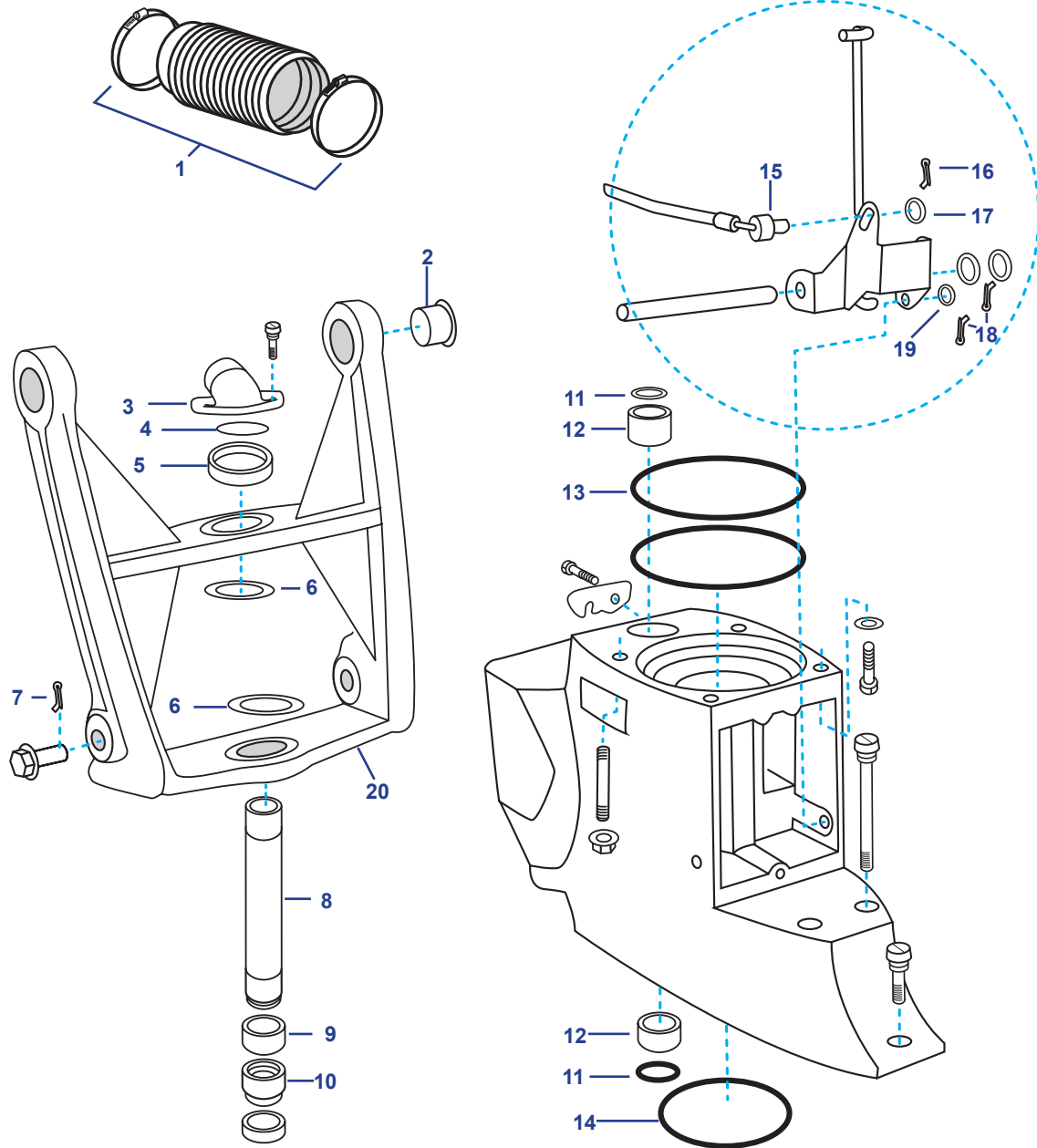

**VOLVO**

Nº	Ref.	R.O. OEM	Descripción	Description	Descrizione
1	REC876631	876631	KIT DE FUELLE	BELLOWS KIT	KIT CUFFIA
2	REC872096	872096	KIT DE CASQUILLO	BUSHING KIT	KIT BOCCOLA
3	REC872752	872752	PIPETA TOMA DE AGUA	PIPE CONNECTION	CONNESSIONE TUBO
4	REC979254	979254	ARO TÓRICO	O-RING	O-RING
5	REC872756	872756	CASQUILLO COJINETE	BEARING BUSHING	BOCCOLA CUSCINETTO
6	REC3860808	3860808	ARANDELA	WASHER	RONDELLA
7	REC967707	967707	PASADOR HENDIDO	PIN	PIN
8	REC872753	872753	MANGUETA GUÍA	STEERING KNUCKLE	MANIGLIA DI GUIDA
9	REC872756	872756	CASQUILLO COJINETE	BEARING BUSHING	BOCCOLA CUSCINETTO
10	REC873534	873534	SOPORTE	SUPPORT	SUPPORTO
11	REC125017	125017	ARO TÓRICO	O-RING	O-RING
12	REC872986	872986	MANGUITO	TUBE	TUBO
13	REC925259	925259	ARO TÓRICO	O-RING	O-RING
14	REC925256	925256	ARO TÓRICO	O-RING	O-RING
15	REC22336734	22336734	CUBO	HUB	CUBO
16	REC17276	17276	PASADOR HENDIDO	PIN	PIN
17	REC940191	940191	ARANDELA	WASHER	RONDELLA
18	REC17253	17253	PASADOR HENDIDO	PIN	PIN
19	REC940191	940191	ARANDELA	WASHER	RONDELLA
20	REC3857140	3857140	HORQUILLA	SUSPENSION FORK	PIN

## TRANSOM DP-S

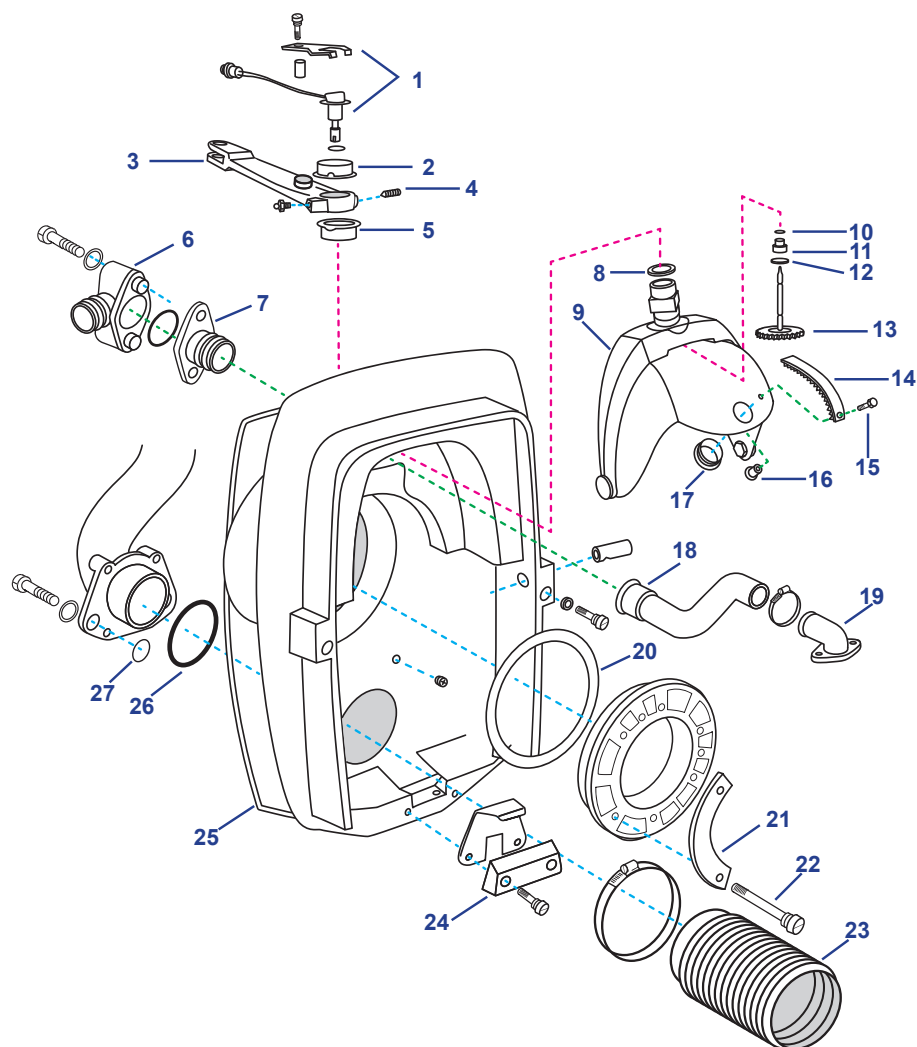

Nº	Ref.	R.O. OEM	Descripción	Description	Descrizione
1	REC22314183	22314183	KIT SENSOR TRIM	TRIM SENSOR KIT	KIT SENSORE TRIM
2	RM854705	854705	CASQUILLO	BUSHING	BOCCOLA
3	REC872722	872722	BRAZO DIRECCIÓN	STEERING ARM	BRACCETTO DIREZIONE
4	REC947904	947904	TORNILLO TOPE	LOCK SCREW FOR STEERING FORK	VITE TRANSOM
5	RM854704	854704	CASQUILLO	BUSHING	BOCCOLA
6	REC872338	872338	CONEXIÓN MANGUERA	HOSE NIPPLE	CONNESSIONE TUBO
7	REC872334	872334	TOMA DE AGUA	NIPLE	TUBO ACQUAL
8	RM977313	977313	RETÉN	SEAL RING	O-RING TENUTA
9	REC872845	872845	HORQUILLA DE MANDO	STEERING YOKE	FORCELLA COMANDO
10	REC925050	925050	ARO TÓRICO	O-RING	O-RING
11	REC851430	851430	CASQUILLO	BUSHING	BOCCOLA
12	REC966207	966207	RETÉN	SEAL RING	O-RING TENUTA
13	RM852984-4	852984	PIÑÓN	PINION	PIGNONE
14	REC872812	872812	SEGMENTO DENTADO	GEAR SEGMENT	CERNIERA TRIM
15	REC853759	853759	TORNILLO	SCREW	VITE
16	REC853760	853760	CASQUILLO TORNILLO CREMALLERA	RIVET NUT	GHIERA VITE CERNIERA
17	REC853048	853048	CASQUILLO	BUSHING	BOCCOLA
18	RM876632	876632	MANGUITO DE AGUA	WATER HOSE	MANICOTTO ACQUA
19	REC872752	872752	PIPETA TOMA DE AGUA	HOSE CONNECTOR PLASTIC	PIPETTA PRESA D'ACQUA
20	REC813967	813967	ARO GOMA (Amarilla. Motores diesel)	RUBBER RING (Yellow. Diesel engines)	O-RING GOMMA (Giallo. Motori diesel)
20	REC804190	813967	ARO GOMA (Verde. Motores gasolina)	RUBBER RING (Green. Fuel engines)	O-RING GOMMA (Verde. Motori benzina)
21	REC806624	806624	PLACA DE BLOQUEO	STRIKER PLATE	PIASTRA
22	REC191844	191844	TORNILLO	SCREW	VITE
23	REC876631	876631	FUELLE	BELLOW	CUFFIA
23	RM876631	876631	FUELLE	BELLOW	CUFFIA
23	CEF500505K	876631	FUELLE	BELLOW	CUFFIA
24	CM852835	852835	ÁNODO DE ZINC	ZINC ANODE	ANODO DE ZINCO
25	REC852868	852868	GOMA TRANSOM	TRANSOM SEAL	GOMMA
26	REC925256	925256	ARO TÓRICO	O-RING	O-RING
27	REC925064	925064	ARO TÓRICO	O-RING	O-RING

TRANSOM SX

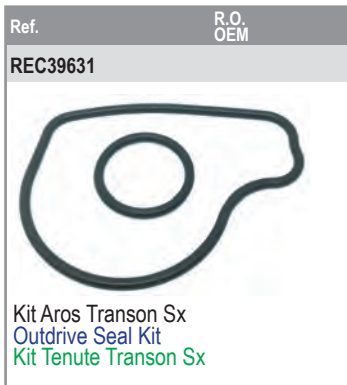
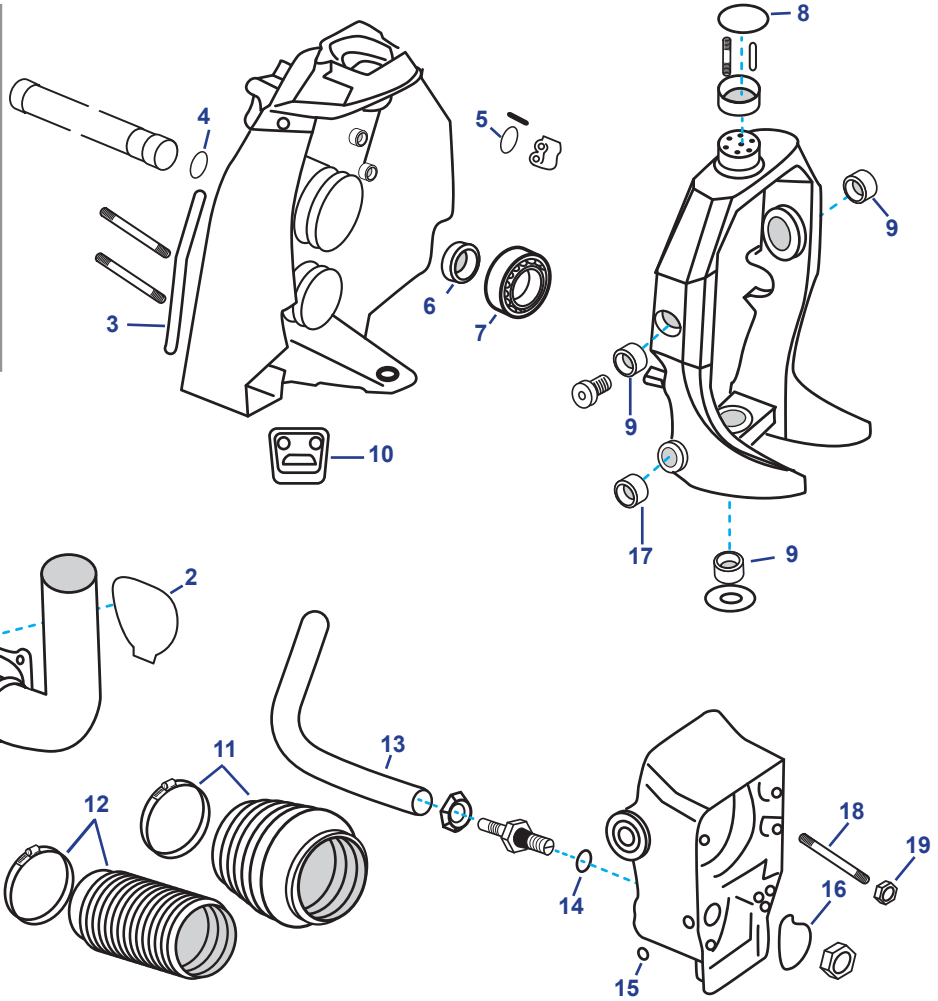

Nº	Ref.	R.O. OEM	Descripción	Description	Descrizione
1	RM3858873	3858873	CUERNOS ESCAPE COLA (4.3, 5.0, 5.7, 8.1)	EXHAUST MANIFOLD ASSEMBLY (4.3, 5.0, 5.7, 8.1)	CORNA DI SCARICO (4.3, 5.0, 5.7, 8.1)
2	RM3587651	3587651	JUNTA CUERNO ESCAPE	SEALING KIT	GUARNIZIONE CORNA DI SCARICO
3	REC3852550	3852550	JUNTA TRANSOM	SEALING TRANSOM	GUARNIZIONE TRANSOM
4	REC309731	3852537	ARO TÓRICO	O-RING	O-RING
5	REC331188	3852169	ARO TÓRICO	O-RING	O-RING
6	REC3852548	3852548	RETEN TRASERO Transom SX	SEALING, DRIVE SHAFT SX	PARAOLIO POSTERIORE SX
6	RM3883257	3883257	RETEN TRASERO Transom SX-A	SEALING, DRIVE SHAFT SX-A	PARAOLIO POSTERIORE SX-A
7	REC30-879194A01	21752712	COJINETE TRANSOM SX	BEARING TRANSOM SX	CUSCINETTO SX
7	RM3888555	3888555	COJINETE TRANSOM SX-A	BEARING TRANSOM SX-A	CUSCINETTO SX-A
8	REC25-33145	3852044	ARO TÓRICO	O-RING	O-RING
9	REC3808228	3808228	CASQUILLO	PIVOT PIN BEARING	BOCCOLA
10	CM3854130	3854130	ÁNODO ZINC	ANODE - ZINC	ANODO ZINCO
10A	CM3854130A	3854130	ÁNODO ALUMINIO	ANODE - ALUMINUM	ANCOO ALLUMINIO
11	REC3841481	3841481	FUELLE COLA con abrazadera	BELLOW KIT	CUFFIA CARDANO con fascetta
11	CEF500514K	3841481	FUELLE COLA con abrazadera	BELLOW KIT	CUFFIA CARDANO con fascetta
12	REC3850426	3850426	MANGUITO ESCAPE	EXHAUST HOSE	MANICOTTO SCARICO
12	CEF500528	3850426	MANGUITO ESCAPE	EXHAUST HOSE	MANICOTTO SCARICO
13	REC3852352	3852352	TUBO SUBIDA AGUA	WATER INLET HOSE	TUBO USCITA ACQUA
14	REC3852535	3852535	ARO TÓRICO	O-RING	O-RING
15	REC332583	3852523	ARO TÓRICO	O-RING	O-RING
16	REC3852560	3852560	RETEN GOMA	SEALING, WATER PASSAGE	TENUTA GOMMA
17	REC3853423	3853423	CASQUILLO	BUSHING	BOCCOLA
18	REC3852551	3852551	ESPÁRRAGO	STUD	PERNO
19	RM3852648	3852648	TUERCA	NUT	DADO

# TRANSOM SX-A TSK

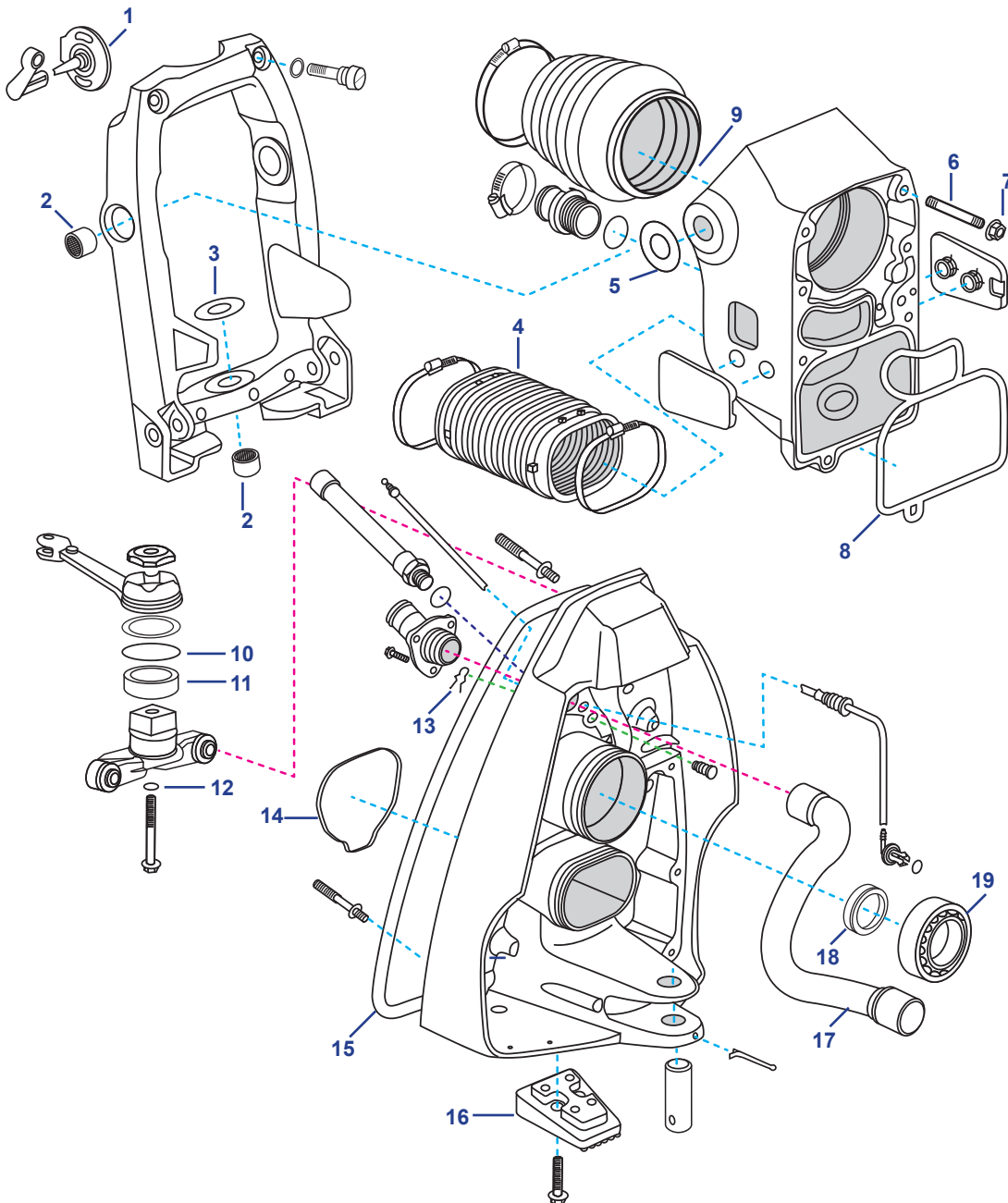

Nº	Ref.	R.O. OEM	Descripción	Description	Descrizione
1	REC21484383	21484383	SENSOR TRIM	TRIM SENDER	SENSORE TRIM
2	REC3808228	3808228	CASQUILLO	BUSHING	BOCCOLA
3	REC3852558	3852558	ARANDELA	WASHER	RONDELLA
4	REC3888916	3888916	FUELLES ESCAPE	EXHAUST BELLOW	CUFFIA SCARICO
5	REC3852558	3852558	ARANDELA	WASHER	RONDELLA
6	REC3852551	3852551	ESPÁRRAGO	STUD	PERNO
7	RM3852648	3852648	TUERCA	NUT	DADO
8	REC3889788	3889788	JUNTA	GASKET	GUARNIZIONE
9	RM22197130	22197130	KIT FUELLE	BELLOW KIT	KIT CUFFIA
10	REC946056	946056	ARO TÓRICO	O-RING	O-RING
11	REC3840761	3840761	CASQUILLO	BUSHING	BOCCOLA
12	REC3852045	3852045	ARO TÓRICO	O-RING	O-RING
13	REC3852555	3852555	SOPORTE	SUPPORT	SUPPORTO
14	REC3841013	3841013	JUNTA	GASKET	GUARNIZIONE
15	REC3841011	3841011	JUNTA	GASKET	GUARNIZIONE
16	CM3841427	3888817	ÁNODO DE ZINC	ZINC ANODE	ANODO ZINCO
16	CM3841427A	3888816	ÁNODO DE ALUMINIO	ALUMINIUM ANODE	ANODO ALLUMINIO
17	REC3883777	3883777	MANGUERA	TUBO	TUBO
18	RM3883257	3883257	RETÉN	SEAL	TENUTA
19	REC3888555	3888555	COJINETE	BEARING	CUSCINETTO



**GUIA KITS RODAMIENTOS Y RETENES TRANSOM  
FLYWHEEL CASING REPAIR KITS GUIDE  
GUIDA KIT CUSCINETTI E PAROLI TRANSOM**



MODELO MOTOR ENGINE MODEL MODELLO MOTORE	MODELO TRANSMISIÓN DRIVE MODEL MODELLO TRASMISSIONE	REF
B 16	80	REC22057
AQD 19	100	REC22057
AQD 21A	250	REC22059
AQD 21A,B	270, 280	REC22074
AQD 27	200	REC22059
AQD 29	200, 250	REC22059
AD 30A	290A, DP	REC22075
AQAD 30A	280DP, PT, 290A, DP	REC22075
AQAD 30A	Cardan drift / Cardan shaft	2 x REC22075
AD 31A,B	290A, DP, SP-C, DP-C, DP-D	REC22075
AQAD 31A	290A, DP	REC22075
TAMD 31 B	SP-A2, DP-A2	REC22075
AQD 32A	250	REC22059
AQD 32A	270, 280	REC22074
AQD 40A	280, DP, PT	REC22075
AQAD 40A,B	280, DP, PT, 290, DP	REC22075
AQAD 40B	Cardan drift / Cardan shaft	2 x REC22075
AD 40B	280, DP, 290, DP	REC22075
AD 41A	290, DP	REC22075
AD 41B	SP-A2-C, DP-C-D-B1	REC22075
AQAD 41 A	290A, DP	REC22075
AQD 41A	290A, DP	REC22075
D 41 B	SP-A2, DP-A2	REC22075
TAMD 41B	SP-A2, SP-C, DP-B1, DP-D	REC22075
KAD 42	SP-D	REC22075
AD31D	DP-D1, SP-C1	REC22161
AD31L-A	DO-D1, SX	REC22161
AD31P-A	DP-D1, SX	REC22161
AD31XD	DP-D1	REC22161
AD41D	DP-D1, SC-C1	REC22161
AD41L-A	DP-D1	REC22161
AD41P-A	DP-D1	REC22161
D14D	DO-D1, SP-C1	REC22161
D41L-A	DP-D1	REC22161
KAD32P-A	DP-E, DP-G, DPX	REC22161
KAD42B	DP-D1, DPX	REC22161
KAD42P-A	DP-D1, DPX	REC22161
KAD43P-A	DP-D, DP-E, DP-G, DPX	REC22161
KAD44P-A	DP-D, DP-E, DP-G, DPX	REC22161
KAD44P-B	DP-D	REC22161
KAD44P-C	DP-E, DP-G, DPX	REC22161
KAD300A	DP-G, DP-E, DPX	REC22161
KAMD42P-A	DP-D1, DPX	REC22161
KAMD44P-C	DP-E	REC22161
KAMD300A	DP-G, DP-E, DPX	REC22161
AD31XD	SP-C1	REC22163
TAMD31D	DP-D1, SP-C1	REC22163



MODELO MOTOR ENGINE MODEL MODELLO MOTORE	MODELO TRANSMISIÓN DRIVE MODEL MODELLO TRASMISSIONE	REF
AQ 171 A,C	290A, SP-A	REC22074
AQ 175, 200B, C, D	280, PT, 290	REC22075
AQ 205A	SP-A, DP-A	REC22075
AQ 211A	290A,DP, SP-A, DP-A	REC22075
AQ 225A, B, C, D, E, F	275, 280, PT, 280L, 290, A, DP	REC22075
230	275, SP-A, SP-A1	REC22074
AQ 231A,B	275, 285, 290A,DP	REC22075
250, 251	SP-A, SP-A1	REC22074
AQ 255A,B	280	REC22075
AQ 260A	280, PT, 290	REC22075
AQ 271A,B,C,D	275, 290A	REC22075
AQ 290A	280PT, 290	REC22075
AQ 311 A,B	290A, SP-A	REC22075
430	SP-A, DP-A	REC22075
430A	SP-A1, SP-A2, SP-C, DP-A, DP-A1, DP-A2, DP-C	REC22075
430B	SP-C, DP-C	REC22075
431A	SP-A, SP-A1, SP-A2, SP-C, DP-A, DP-A1, DP-A2, DP-C	REC22075
431B	SP-C, DP-C	REC22075
432A	SP-C1, DP-C1	REC22055
434A	SP-C1, DP-C1	REC22055
500B	SP-A1, SP-A2, SP-C, DP-A1, DP-A2, DP-C	REC22075
500B	SP-C1, DP-C1, DP-D1	REC22055
501B	SP-A2, SP-C, DP-A2, DP-C	REC22075
501B	SP-C1, DP-C1, DP-D1	REC22055
570A	SP-A, SP-A1, SP-A2, SP-C, DP-A, DP-A1, DP-A2	REC22075
570A	SP-C1, DP-C1, DP-D1	REC22055
572A	SP-C, DP-C	REC22075
572A	SP-C1, DP-C1, DP-D1	REC22055
740A	DP-B, DP-B1, DP-C	REC22075
740B	DP-C, DP-C	REC22075
740B	SP-C1, DP-C1, DP-D1	REC22055
AQ 115A,B,C	250	REC22059
AQ 120A	200	REC22059
AQ 120B	270	REC22074
AQ 125A,B	270, 275A	REC22074
AQ 130	100	REC22057
AQ 130	250	REC22059
AQ 130	270, 270T, 280	REC22074
AQ 131A,B,C,D	275, 290, SP-A	REC22074
AQ 140A	280, 280PT	REC22074
AQ 145A,B	280, 280PT, 290	REC22074
AQ 151A,B,C	290, 290A, SP-A	REC22074
AQ 165A	250	REC22060
AQ 165A	250	REC22074
AQ 170	250, 270, 270T, 280, 280T	REC22074
AQ 170	270	REC22060



REC22057



REC22161



REC22074



REC22060



REC22059



REC22163



REC22055



REC22075

# KITS REPARACIÓN AQUAMATIC AQUAMATIC KITS KITS RIPARAZIONE AQUAMATIC

## PIPETA TOMA AGUA HOSE CONNECTOR PIPETTA

Ref.	R.O. OEM
REC854031	854031



## MOTORES / ENGINES / MOTORI 280

Ref.	R.O. OEM
REC832846	832846



## MOTORES / ENGINES / MOTORI AQ200-290 AQSP, DP

Ref.	R.O. OEM
REC872752	872752



## MOTORES / ENGINES / MOTORI DP, D, E, G, H, X Plástico / plastic / in plastica

Ref.	R.O. OEM
REC40005192	40005192



## MOTORES / ENGINES / MOTORI DPH-A, B, C DPR-A, B, C

## ARO TOMA AGUA SWIVEL BUSHING FOR PIPE BOCCOLA

Ref.	R.O. OEM
REC814388	814388



## MOTORES / ENGINES / MOTORI 250, 270, 280

## ARANDELA PLÁSTICO PLASTIC WASHER RONDELLA IN PLASTICA

Ref.	R.O. OEM
REC814390	814390



Ref.	R.O. OEM
REC850888	850888



## MOTORES / ENGINES / MOTORI AQ200, 250, 270, 275, 280, 285, 290 SP-A, A, MT, A1, A2, C, C1

## CASQUILLOS HORQUILLA PLASTIC BUSHINGS BOCCOLA FORCELLA

Ref.	R.O. OEM
REC876278	826341

Todos con Tilt eléctrico  
All with Electric Tilt  
Tutti modelli con Tilt elettrico



Ref.	R.O. OEM
REC832820	832820

## MOTORES / ENGINES / MOTORI Power Trim AQ270T, 280T



Ref.	R.O. OEM
REC876279	876279 853223

## MOTORES / ENGINES / MOTORI Power Trim AQ290, SP, DP



Ref.	R.O. OEM
REC872096	876507 872096

## MOTORES / ENGINES / MOTORI Power Trim DPE DPX, -S1 DP-C1, D1



## PASADOR SETTING PIN CHIAVISTELLO

Ref.	R.O. OEM
REC814301	814301



Ref.	R.O. OEM
REC814419	814419

## MOTORES / ENGINES / MOTORI AQ290, A DP, A, A1, A2, B1 SP-A, A1, A2



## JUNTA GOMA RUBBER GASKET GUARNIZIONE IN GOMMA

Ref.	R.O. OEM
REC814356	814356



**MUELLES  
SPRINGS  
MOLLE**

Ref.	R.O. OEM	
REC23170		KIT
REC832534	832534	
REC814396	814396	
REC814332	814332	



REC23170



REC832534

REC814396

REC814332

**ARANDELA SEGURO TUERCA  
PROP LOCK TAB WASHER  
RONDELLA DI SICUREZZA**

Ref.	R.O. OEM
REC897367	897367



**MOTORES / ENGINES / MOTORI  
AQ200, 250, 270, 275, 280, 285, 290  
SP-A, A, MT, A1, A2, C, C1**

**CORTALÍNEAS  
THRUST RING  
REGGIPINTA**

Ref.	R.O. OEM
REC839423	839423



**MOTORES / ENGINES / MOTORI  
280-290 SP, 285**

Ref.	R.O. OEM
REC872082	872082



**MOTORES / ENGINES / MOTORI  
SP-E, A2**

Ref.	R.O. OEM
REC839534	839534



**MOTORES / ENGINES / MOTORI  
250, 270, 275**

**TORNILLO  
SCREW  
VITE**

Ref.	R.O. OEM
REC850889	850889



Para tuerca / for nut / per dado: 289/290 SP

**GRUESO TRASERO HÉLICE DP  
THRUST WASHER DP  
SPESSORE POSTERIORE ELICA DP**

Ref.	R.O. OEM
REC3858457	3858457
	3856070
	872891
	852206
REC3858458	3858458
	3857307
	3856069
	872872



REC3858457



REC3858458

**MOTORES / ENGINES / MOTORI  
DP-E, G, C1, D1**

**KITS**

Ref.	R.O. OEM
REC23120	

**CONTIENE / CONTAINS / CONTIENE**

Ref.	R.O. OEM
REC854045	854045
REC854047	854077
REC897367	897367
REC850888	850888
REC850889	850889



REC854047



REC854045



REC850889



REC850888



REC897367

**KIT TUERCA HÉLICE DP EJE 16 mm  
PROP & NUT KEEPER 16 mm  
KIT DADO ELICA DP ASSE 16 mm**

Ref.	R.O. OEM
RM872614	872614
	854057
	854666
	853655



**NEW**

**KIT TUERCA HÉLICE DP EJE 20 mm  
PROP & NUT KEEPER 20 mm  
KIT DADO ELICA DP ASSE 20 mm**

Ref.	R.O. OEM
RM872549	872549



**NEW**

**KITS TUERCAS SX COBRA  
PROP NUTS KITS SX COBRA  
KIT DADI SX COBRA**

**TOPE HÉLICE  
SPLINE WASHER  
SPESSORE ELICA**

Ref.	R.O. OEM
REC3852350	3852350



**CIERRE HÉLICE  
THICK THRUST WASHER  
CHIUSURA ELICA**

Ref.	R.O. OEM
REC126870	3852020



**PASADOR  
COTTER PIN  
COPPIGLIA**

Ref.	R.O. OEM
REC3852056	3852056



**TUERCA 3/4X16 CON PASADOR**  
**NUT WITH PIN**  
**DADO CHIUSURA 3/4 X 16 CON SPINOTTO**

Ref.	R.O. OEM
REC398042	3850984



**KIT SIN ARANDELA**  
**KIT WITHOUT THRUST WASHER**  
**KIT SENZA RONDELLA**

Ref.	R.O. OEM
REC22188	3850984

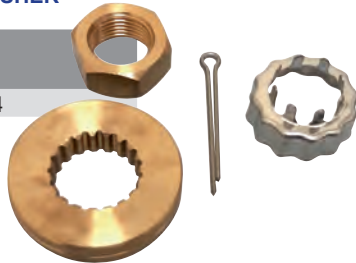

**KIT CIERRE HÉLICE**  
**PROP KIT WASHER**  
**KIT CHIUSURA ELICA**

Ref.	R.O. OEM
REC22189	3850984



**KITS REPARACIÓN COLAS E INVERSORES**  
**GASKET SET STERN DRIVES & INVERTERS**  
**KITS RIPARAZIONE PIEDI E INVERTITORI**

**KITS COMPLETOS**  
**FULL KIT**  
**KIT COMPLETO**

Ref.	R.O. OEM
REC19035	

**MOTORES / ENGINES / MOTORI**

AQ Drives.  
 DP-C1, D1, E  
 DPX-S, S1



Ref.	R.O. OEM
REC875741	876266+876267 875741

**MOTORES / ENGINES / MOTORI**

AQ 250, 270, 275, 280, 285, 290  
 (Con carcasa inferior DP  
 with DP lower housing  
 con carcassa inferiore DP)  
 DP-A, A1, B, C, D



Ref.	R.O. OEM
REC19037	876266+876268

**MOTORES / ENGINES / MOTORI**  
 excepto / except / *eccetto* DP  
 AQ 200, 250, 270, 275, 280, 285, 290  
 SP-A, MT, A1, A2, C



Ref.	R.O. OEM
REC876391	876391 875720



**MOTORES / ENGINES / MOTORI**  
 120C, D, S, B  
 S120C



Ref.	R.O. OEM
REC23009	



**MOTORES / ENGINES / MOTORI**  
 DPH-A, B, C  
 DPR-A, B, C



Ref.	R.O. OEM
REC23027	



**MOTORES / ENGINES / MOTORI**

DPH-D  
 DPR-D



Ref.	R.O. OEM
REC3859050	3859050



**MOTORES / ENGINES / MOTORI**

XDP-B  
 X-B, BLT  
 XHP-BLT  
 XXP-A, ALT, D3



**KIT INFERIOR  
LOWER KIT  
KIT INFERIORE**

Ref.	R.O. OEM
REC876267	

**MOTORES / ENGINES / MOTORI**  
DP-C1, D1, E  
DPX-S, S1



Ref.	R.O. OEM
REC22086	

**MOTORES / ENGINES / MOTORI**  
excepto / except / eccetto DP  
AQ 250, 270, 275, 280, 285, 290  
SP-A, MT, A1, A2, C, C1

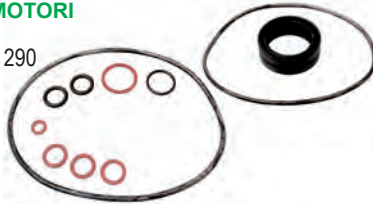

Ref.	R.O. OEM
REC22087	

**MOTORES / ENGINES / MOTORI**  
DP-A, A1, A2, B, B1, C, C1, D, D1  
DPX-S, S1  
Eje hélice  
Drives shaft  
Asse elica



Ref.	R.O. OEM
REC876268	876268

**MOTORES / ENGINES / MOTORI**  
AQ 200, 250, 270, 275, 280, 285, 290,  
SP-A, A/MT, A1, A2, C



Ref.	R.O. OEM
REC876267	876267

**MOTORES / ENGINES / MOTORI**  
AQ280DP, 290DP  
DP-A, A1, A2, B1, C, D



Ref.	R.O. OEM
REC22151	

**MOTORES / ENGINES / MOTORI**  
200, 250, 270, 275, 280, 290  
SP-A, C

**CONTIENE / CONTAINS / CONTIENE**

Ref.	R.O. OEM
REC125017	125017
REC839253	853670
REC925256	925256
REC925259	925259
REC955974	955974
REC956000	956000



Ref.	R.O. OEM
REC23018	

**MOTORES / ENGINES / MOTORI**  
DPH-A, B, C  
DDPR-A  
DPR-B, C



**NEW**

Ref.	R.O. OEM
REC23033	

**MOTORES / ENGINES / MOTORI**  
130S-A, S-B, R-A, R-B  
150S-A, S-B, R-A, R-B

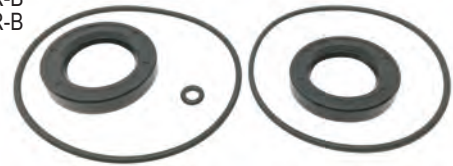

**NEW**

**KIT INFERIOR- EJE HÉLICE  
LOWER KIT - SHAFT PROPELLER  
KIT INFERIORE - ASSE ELICHA**

Ref.	R.O. OEM
REC22085	

**MOTORES / ENGINES / MOTORI**  
120C-D, S, S-B  
S120C



**NEW**

Ref.	R.O. OEM
REC23008	

**MOTORES / ENGINES / MOTORI**  
120S-E  
MS25S-A, R-A



**NEW**

**KIT INFERIOR DP**  
**LOWER KIT DP**  
**KIT INFERIORE DP**

Ref.	R.O. OEM
REC3856002	3856002

**MOTORES / ENGINES / MOTORI**  
 DP-CS, S1, SM



**NEW**

Ref.	R.O. OEM
REC23020	3888822

**MOTORES / ENGINES / MOTORI**  
 DPS-A, B



**NEW**

Ref.	R.O. OEM
REC3855275	3855275

**MOTORES / ENGINES / MOTORI**  
 SX-C, C1, C2, CT, CTI, R, RTI, M, MI, MTD



**NEW**

Ref.	R.O. OEM
REC23022	3888821

**MOTORES / ENGINES / MOTORI**  
 SX-A



**NEW**

Ref.	R.O. OEM
REC23025	

**MOTORES / ENGINES / MOTORI**  
 XDP-B, X-B, X-BTL, XHP, BLT, XXP-A, XXP-ALT, XXP-D3

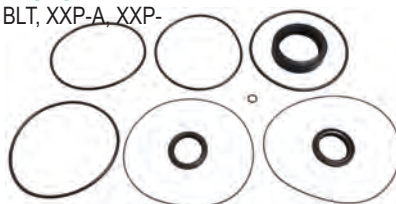

**NEW**

Ref.	R.O. OEM
REC22612828	22612828

**MOTORES / ENGINES / MOTORI**  
 FWD



**NEW**

**KIT SUPERIOR**  
**UPPER KIT**  
**KIT SUPERIORE**

Ref.	R.O. OEM
REC876266	876266

**MOTORES / ENGINES / MOTORI**  
 AQ 250, 270, 275, 280, 285, 290  
 SP-A, A/MT, A1, A2, C,  
 DP-A, A1, A2, B1, C, D



Ref.	R.O. OEM
REC19029	

**MOTORES / ENGINES / MOTORI**  
 DPX-, S, S1  
 SP-C1  
 DP-C1, D1, E, S1

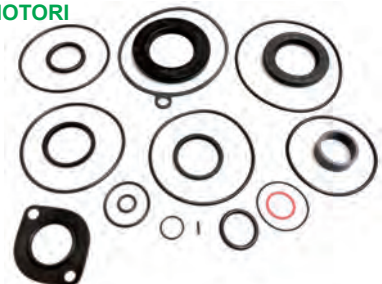

Ref.	R.O. OEM
REC22151	

**MOTORES / ENGINES / MOTORI**  
 AQ270, 270T, 275, 275A, 280, 280DP, 280T,  
 285A, 290, 290A, 290DP  
 SP-A, A/MT, A1, A2, C, C1  
 DP-A, A1, A2, B, B1, C, C1, D, D1, E  
 DPX, S



**NEW**

Ref.	R.O. OEM
REC22097	

**MOTORES / ENGINES / MOTORI**  
 120C-D, S, S-B  
 S120C



**NEW**

Ref.	R.O. OEM
REC3850594	3850594

**NEW**

**MOTORES / ENGINES / MOTORI**  
SX-C, C1, C2, CT, CT1, R, RT1, RT2, M, MTD, M1  
DPS, SM

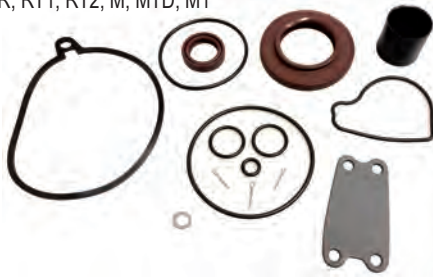

Ref.	R.O. OEM
REC3888917	3888917 876392

**NEW**

**MOTORES / ENGINES / MOTORI**  
SX-A  
DPS-A, B, B1  
FWD



Ref.	R.O. OEM
REC23010	

**NEW**

**MOTORES / ENGINES / MOTORI**  
DPH-A, B, C, D, D1  
DDPR-A  
DPRB, C, D



Ref.	R.O. OEM
REC23024	

**NEW**

**MOTORES / ENGINES / MOTORI**  
XDP-B  
X-B, BLT  
XHP-BLT  
XXP-A, ALT, D3



Ref.	R.O. OEM
REC23019	

**NEW**

**MOTORES / ENGINES / MOTORI**  
DPH-A, B, C, D  
DDPR-A  
DPRB, C, D



Ref.	R.O. OEM
REC23034	

**NEW**

**MOTORES / ENGINES / MOTORI**  
DP-G  
DPX-A



**KIT INVERSORES  
INVERTERS KIT  
KIT INVERTITORI**

Ref.	R.O. OEM
REC876588	876588

**NEW**

HS1



Ref.	R.O. OEM
REC876073	876073

**NEW**

MS4



**RETENES Y AROS TÓRICOS  
SEALS & RUBBER O-RINGS  
PARAOLI E O-RINGS**

**RETÉN EJE DE HÉLICE  
DRIVES SEALING RING  
PARAOLIO ASSE ELICA**

Ref.	R.O. OEM
REC3593663	3593663

**MOTORES / ENGINES / MOTORI**  
130S-A, S-B, R-A, SR-B  
150S-A, S-B, SR-A, SR-B  
120S-E, S-D  
MSZ25S-A, SR-A



Ref.	R.O. OEM
REC897426	897426

**MOTORES / ENGINES / MOTORI**  
AQ200, 250, 270, 270T, 275, 275A, 280T,  
280L, 285A, 290A  
SP-A, A/MT, A1, A2, C



Ref.	R.O. OEM
REC3863090	3863090 3858303

**NEW**

**MOTORES / ENGINES / MOTORI**  
SX



Ref.	R.O. OEM
REC3863083	3863083 EXT / OUT
REC3863080	3863080+3863081 INT / IN

**MOTORES / ENGINES / MOTORI**  
DPH

**NEW**



REC3863080

**NEW**



REC3863083

Ref.	R.O. OEM
REC853868	853868

**MOTORES / ENGINES / MOTORI**  
SP  
DP



**RETÉN EJE TIPO JACKS**  
**DRIVES SEALING RING TYPE JACKS**  
**PARAOLIO ASSE ELICA TIPO JACKS**

Ref.	R.O. OEM
REC858464	858464

**MOTORES / ENGINES / MOTORI**

AD31D-A, L-A, P-A  
AD41B, D, L-A, P-A,  
AQAD41A  
D41D, L-A  
TAMD31, A, B  
TAMD41A, B, D  
TMD41D  
KAD32P, 42B, 43P-A, 44P  
D4-180I-B, I-C, I-D, I-E, I-F  
D4-210A-A, I-A, I-B, A-B  
D4-225I-B, A-C, A-D, I-C, I-D, A-E, I-E  
D4-260A-A, A-B, A-C, A-D, D-B, D-C, D-D, I-A, I-B, I-C, I-D, A-E, D-E, I-E  
D4-300A-A, A-C, A-D, D-A, D-C, I-A, I-C, I-D, A-E, D-E, D-D, I-E  
D6-280A-A, A-B, A-C, A-D, A-E, I-A, I-B, I-C, I-D, I-E  
D6-310I-A, A-A, A-B, A-C, A-D, D-B, D-C, D-D, I-B, I-C, I-D, A-E, D-E, I-E, D-A  
D6-330A-B, A-C, A-D, D-B, D-C, D-D, I-B, I-C, I-D, A-E, D-E, I-E  
D6-350A-A, A-B  
D6-370A-B, A-C, A-D, D-B, D-C, D-D, I-A, I-B, I-C, I-D, A-E, D-E, I-E, D-A  
D6-400A-E  
D6-435D-A, D-D, D-C, D-E, I-A, I-C, I-D, I-E



**NEW**

**RETENES PEQUEÑOS. EJE DE HÉLICE**  
**DRIVES SEALING LITLE RING**  
**PARAOLIO PICCOLO. ASSE ELICA**

Ref.	R.O. OEM
REC853808	853808 853871

**MOTORES / ENGINES / MOTORI**

AQ 280DP, 290DP  
DP-A, A2, B1, C, D  
XDP  
DPS-A, B  
FWD



**RETENES GRANDES. EJE DE HÉLICE**  
**DRIVES SEALING BIG RING**  
**PARAOLIO GRANDE. ASSE ELICA**

Ref.	R.O. OEM
REC851407	851407

**MOTORES / ENGINES / MOTORI**

AQ 280DP, 290DP  
DP-A, A2, B1, C, D  
XDP



## GOMAS SEALING STRIPS GOMMA

**GOMA CAMPANA**  
**RUBBER RING**  
**GOMMA CAMPANA**

Ref.	R.O. OEM
REC813967	813967
REC804190	804190



**GOMA CIERRE IPS**  
**IPS RUBBER LOCK**  
**GOMMA CHIUSURA IPS**

Ref.	R.O. OEM
REC22256171	22256171 3861068



**NEW**

**GOMA TRANSOM**  
**SEALING STRIP**  
**GOMMA TRANSOM**

Ref.	R.O. OEM
REC897726	897726

**MOTORES / ENGINES / MOTORI**  
AQ 200, 250, 270, 270T, 275, 275A  
AQ280, T, D, P, SP-A/MT



Ref.	R.O. OEM
REC852868	852868

**MOTORES / ENGINES / MOTORI**  
AQ290, A, DP  
SP-A, A1, A2, C, C1  
DP-A1, A2, B, B1, C, C1, D, D1, X



## FUELLES DE TRANSMISIÓN DRIVE BELLOW KITS CUFFIE CARDANO

Ref.	R.O. OEM
REC875512	875512 875827 804186

**MOTORES / ENGINES / MOTORI**  
AQ80, 100, 100B, 100S



Ref.	R.O. OEM
REC876294	876294
CEF500510K	875826
RM876294	897889

**MOTORES / ENGINES / MOTORI**  
AQ200, 250, 270, 270T, 275, 275A, 280, 280T,  
280DP, 280PT, 290, 290A, 290DP  
SP-A, A1, A2, C  
DP-A, A1, A2, B, B1, C, D, X



Ref.	R.O. OEM
REC3808898	3808898
CEF500537K	3594509

**MOTORES / ENGINES / MOTORI**  
DPH-A, B, C, D  
DPR-A, B, C, D





Ref.	R.O. OEM
REC3841481	3841481
CEF500514K	3854127
RM22197130	22197130

**MOTORES / ENGINES / MOTORI**  
SX-S, C1, C2, R, R1, R2, A  
SM-M, M1  
DP-SM  
DPS-A, B



RM22197130 (Nuevo diseño de goma rígida / New design rigid rubber / Nuovo design in gomma rigida)

Ref.	R.O. OEM
	21277185
RM21277185	3886847
	3841482

**MOTORES / ENGINES / MOTORI**  
XDP-B  
X-BLT  
TSK / XHP



**FUELLES DE ESCAPE  
EXHAUST BELLOW KITS  
CUFFIE SCARICO**

Ref.	R.O. OEM
REC876631	876631
CEF500505K	875848
RM876631	

**MOTORES / ENGINES / MOTORI**  
AQ 200, 250, 270, 275, 280, 280DP, 290, 290DP  
SP-A, A/MT, A1, A2, C  
DP-A, A1, A2, B, C, D, X  
Con protección metálica. Sin válvula.  
With metallic protection, w/o valve.  
Con protezione metallica. Senza valvola.



Ref.	R.O. OEM
REC876633	
CEF500505FL	876633
RM876633	

**MOTORES / ENGINES / MOTORI**  
AQ 280, 280T, 280PT, 280DP  
SP-A  
DP-A, A1, A2, B, C, D, X  
Con protección metálica. Con válvula.  
With metallic protection, with valve.  
Con protezione metallica. Con valvola.



Ref.	R.O. OEM
REC3850426	3850426
CEF500528	

**MOTORES / ENGINES / MOTORI**  
SX-S, C1, C2, R, R1, R2, M, M1  
DP-SM



Ref.	R.O. OEM
REC3888916	3888916
CEF500536K	

**MOTORES / ENGINES / MOTORI**  
SX-A  
DPS-A, B



Ref.	R.O. OEM
	3588753
CEF500538K	3808536
	3862168

**MOTORES / ENGINES / MOTORI**  
DPH-A, B, C, D  
DPR-A, B, C, D



Ref.	R.O. OEM
RM3885870	3885870

**MOTORES / ENGINES / MOTORI**  
X-B, BLT  
TSK



Ref.	R.O. OEM
REC3860384	3860384
	3858139

**MOTORES / ENGINES / MOTORI**  
DP-G  
DPX-A



**MANGUITOS DE ESCAPE  
EXHAUST HOSE  
MANICOTTO SCARICO**

Ref.	R.O. OEM
REC3584167	3584167

**MOTORES / ENGINES / MOTORI**  
D4  
DPH / DPR



Ref.	R.O. OEM
REC3584168	3584168

**MOTORES / ENGINES / MOTORI**  
D6  
DPH / DPR



Ref.	R.O. OEM
REC3852696	3852696

**MOTORES / ENGINES / MOTORI**  
4.3 (1991),  
5.0-5.8 FORD (1991)  
7.4 (460) (1988-89)  
5.7LE (1990-91)  
Modelos modernos / Latest models / Modelli  
moderno 4.3 / 5.0 / 5.7 / 7.4 / 8.1



Ref.	R.O. OEM
REC3863450	3863450

**MOTORES / ENGINES / MOTORI**

2.5 (1986)  
3.0 (1986-91)  
2.3 (1989-90)  
4.3 (1990-91)  
5.0-5.8 FORD (1991)  
5.7 (1986)

Modelos modernos / Latest models / Modelli  
moderno 3.0 / 4.3 / 5.0 / 5.7 / 7.4 / 8.1 / D3



Ref.	R.O. OEM
RM3853608	3853608

**MOTORES / ENGINES / MOTORI**

Ford 5.0 & 5.8 HD, MD & NC  
(Para codos / For elbows / per gomito F.I.)



Ref.	R.O. OEM	
REC834751	834751	160 mm x Ø in 95 mm

**MOTORES / ENGINES / MOTORI**

AQ 175, 280, 430A, 431A  
V6  
V8



Ref.	R.O. OEM
RM843228	843228

**MOTORES / ENGINES / MOTORI**

AQ / AD 30, 40



Ref.	R.O. OEM
RM858955	858955
CEF500530	858729

**MOTORES / ENGINES / MOTORI**

AQ 31, 41



Ref.	R.O. OEM
RM860396	860396
CEF500531	

**MOTORES / ENGINES / MOTORI**

D31, 32, 41, 42, 43, 44, 300



Ref.	R.O. OEM	
REC952980	952980	200 mm x Ø in 57 mm

**MOTORES / ENGINES / MOTORI**

AQ 60, 90, 95, 105, 110, 115, 120A, 130



**KIT REPARACIÓN TUBO ESCAPE  
REPAIR KIT EXHAUST TUBE  
KIT RIPARAZIONE SCARICO**

Ref.	R.O. OEM	TUBO TUBE TUBO
RM3581114	3581114	3.5"
RM3581115	3581115	4"



**MANGUITOS DE COLA  
DRIVE HOSE  
MANICOTTO PIEDE**

Ref.	R.O. OEM
REC875822	875822
CEF501011	22303438

**MOTORES / ENGINES / MOTORI**

AQ 200, 250, 270, 275, 280, 280DP,  
280PT, 285A  
SP-A/MT



Ref.	R.O. OEM
CEF501002	876632
RM876632	875747
	854555

**MOTORES / ENGINES / MOTORI**

AQ290, 290A, 290DP  
SP-A, A1, A2, C  
DP-A, A1, A2, B, B1, C, D, X



Ref.	R.O. OEM
REC832831	832831

**MOTORES / ENGINES / MOTORI**

AQ 270T, 280T



Ref.	R.O. OEM
CEF501010	3852352
REC3852352	

**MOTORES / ENGINES / MOTORI**

SX  
DP-S



**GOMA PASACASCOS  
THRU HULL BELLOW  
GOMMA PASSASCAFO**

Ref.	R.O. OEM
CEF501001	854932
	22303438

**MOTORES / ENGINES / MOTORI**

110, 120, 120S  
MS25

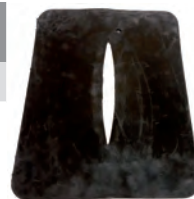

**KIT INSTALACIÓN  
REPAIR KIT  
KIT RIPARAZIONE**

Ref.	R.O. OEM	
REC21389074	21389074	3856597
	21112450	877362
	3840050	872026

**MOTORES / ENGINES / MOTORI**

110, 120, 120S, 130, 150  
MS25S, SR



**ACOPLAMIENTOS  
COUPLERS  
PARASTRAPPI**

Ref.	R.O. OEM	AGUJERO HOLE FUORI	CUBO SALIDA HUB OUTER CUBO
REC3853962	3853962	Ø 91 mm	Ø 43 mm

**MOTORES / ENGINES / MOTORI**

2.5L (1986)  
3.0L (1986-90)  
4.3L  
5.0L  
5.7L (1986) KX & KWB  
7.4L (1990-98)  
8.2L (1992-93, 1998)  
DPX375, 385, 415



Ref.	R.O. OEM	AGUJERO HOLE FUORI	CUBO SALIDA HUB OUTER CUBO
REC3858437	3853917	Ø 76 mm	Ø 43 mm

**MOTORES / ENGINES / MOTORI**

4.3L (1986-98)  
5.0L (1986-88, 1998)  
5.7 (1986-92, 1994, 1996-98)



**SILEMBLOCK**

Ref.	R.O. OEM
REC803762	803762

**MOTORES / ENGINES / MOTORI**

BB30, 100, 115, 165, 170  
MB10A, 18, 20  
2001, 2002, 2003, 2010, 2020, 2030, 2040  
D1, 2  
MD1, 2, 3, 5, 6, 7, 11, 17, 21, 22, 29, 32

AQD2  
D1-13A, B, F  
D1-20A, B, F  
D1-30A, B, F  
D2-40A, B, F  
D2-55A, B, C, D, E, F  
D2-75A, B, C, F



**NEW**

Ref.	R.O. OEM
REC843323	843323

**MOTORES / ENGINES / MOTORI**

AQAD40A, B  
AQAD41A  
AQD40A  
AD41A, B, D, L-A, P-A  
D41A, B, D, L-A  
KAD42A, B, P-A



**NEW**

**KIT PRENSAESTOPAS DE GOMA  
RUBBER SEAL KIT  
KIT PREMISTOPPA IN GOMMA**

Ref.	Ø EJE Ø SHAFT Ø ASSE	A	B	C
RM828254	25 mm	36 mm	66 mm	42 mm
RM828422	30 mm	36 mm	72 mm	48 mm
RM828526	35 mm	36 mm	82 mm	54 mm
RM828527	40 mm	36 mm	82 mm	60 mm
RM3819722	45 mm	36 mm	95 mm	64 mm
RM3819723	50 mm	36 mm	95 mm	68 mm
RM3819724	1"	36 mm	66 mm	1-5/8"
RM3819725	1 1/4"	36 mm	76 mm	2"
RM3819726	1 1/2"	36 mm	85 mm	2-1/4"
RM3819727	1 3/4"	36 mm	95 mm	2-1/2"
RM3819728	2"	36 mm	95 mm	2-1/2"

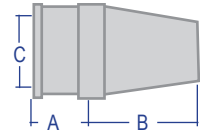

**DAMPER  
DRIVE PLATE  
DAMPER**

Ref.	R.O. OEM	VOLANTE FLYWHEEL VOLANTE
REC855694	855694 835550 855648	14"

**MOTORES / ENGINES / MOTORI**

430B  
431B  
432A  
434A  
570A  
572A  
500B  
501B-MS4  
570A-MS4  
BB225A, B, C  
BB260A, B, C  
231A  
261A  
4.3L HU, LK, GL, NC  
5.7L Gi-HU, LK, MD, NC

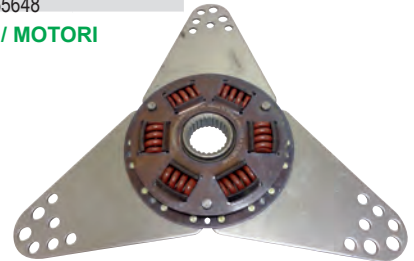

Ref.	R.O. OEM	AGUJERO HOLE FUORI	SPLINES
REC855389	855389 831778 841895	Ø 34 mm	26

**MOTORES / ENGINES / MOTORI**

230A, B  
250A, B  
251A  
AD31A, B, D, XD  
AQ115A, B  
AQ120B  
AQ125A, B  
AQ130A, B, C, D  
AQ140A  
AQ145A, B  
AQ151A, B, C  
AQ171A, C  
AQAD31A, 40B  
AQD40A

BB115A, B, C  
BB140A  
BB145A  
KAD32P  
MB20A, B, C  
MB30A, 31A, 40A  
TAMD30A, B  
TAMD31A, B, D  
TAMD40A, B  
TMD30A  
TMD31A, B, D  
TMD40A, B, C



Ref.	R.O. OEM	AGUJERO HOLE FUORI	SPLINES
REC855617	855617	Ø 34 mm	26

**MOTORES / ENGINES / MOTORI**  
 AD41A, B, D KAD44PEDC  
 AQAD41A KAMD42A, B  
 D41A, B, D TAMD41A, B  
 KAD42A, B, D, P TMD41A, B  
 KAD43P KAD300A



## TORNILLO SOPORTE ELÁSTICO ADJUSTABLE SCREW VITI REGOLABILI

Ref.	R.O. OEM
REC861431	861431

**MOTORES / ENGINES / MOTORI**  
 D1-13A, B, F  
 D1-20A, B, F  
 D1-30A, B, F  
 D2-40A, B, F  
 MD2010A, B, C, D  
 MD2020A, B, C, D  
 MD2030A, B, C, D  
 MD2040A, B, C, D  
 AQAD40A, B  
 AQAD41A  
 AQD40A  
 AD41A, B, D, L-A, P-A  
 D41A, B, D, L-A  
 KAD42A, B, P-A



## SOPORTES ELÁSTICOS FLEXIBLE ENGINE MOUNTS SUPPORTI ELASTICI

Ref.	CARGA MÁX. MAX LOAD CARICA MAX
GS38103	55 kg / 120 lbs
GS38104	160 kg / 355 lbs

Fabricado en metal y neopreno vulcanizado.  
 Manufactured in metal and vulcanized neoprene.  
 Supporto elastico in metallo e neoprene

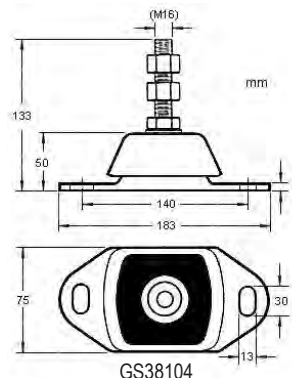
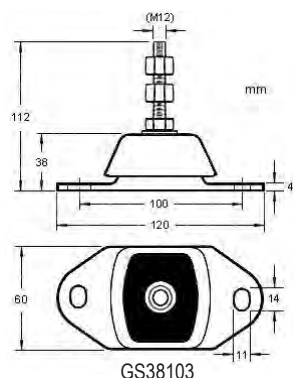
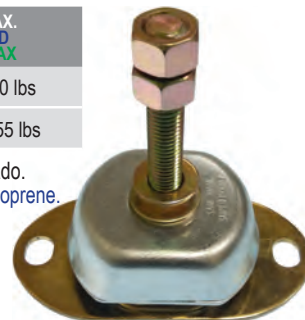

## ÁNODOS ANODES ANODOS

### TECNOSEAL

ZN	R.O. OEM	Ø	KG (kg)	MOTORES ENGINES MOTORI
TEN00700	875810	100 mm	0,20	50-100
TEN00701	875809	108 mm	0,26	
TEN00702	875805	114	0,28	



ZN	R.O. OEM	KG (kg)	MOTORES ENGINES MOTORI
TEN00704BIS	875821	0,47	DUO PRO 290 (2002+)



ZN	R.O. OEM	KG (kg)	MOTORES ENGINES MOTORI
TEN00703	875815	0,76	280 - 290



ZN	R.O. OEM	KG (kg)	MOTORES ENGINES MOTORI
TEN00705	875812	0,94	S. DRIVE 110



ZN	R.O. OEM	KG (kg)	MOTORES ENGINES MOTORI
TEN00706	876286 851983	0,53	S. DRIVE 120



ZN	R.O. OEM	KG (kg)	MOTORES ENGINES MOTORI
TEN00717	872793	0,11	DUO PRO 290



ZN	R.O. OEM	KG (kg)	MOTORES ENGINES MOTORI
TEN00708	852835	0,75	DUO PRO 290



ZN	R.O. OEM	KG (kg)	MOTORES ENGINES MOTORI
TEN00718	3854130	1,05	S. DRIVE - SX DRIVE



ZN	R.O. OEM	KG (kg)	MOTORES ENGINES MOTORI
TEN00722	873395	0,37	DPX



ZN	R.O. OEM	KG (kg)	MOTORES ENGINES MOTORI
TEN00723	876638	0,22	DPX

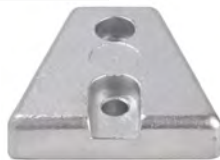

ZN	R.O. OEM	KG (kg)	MOTORES ENGINES MOTORI
TEN00724	872139	0,69	DPX



ZN	R.O. OEM	KG (kg)	MOTORES ENGINES MOTORI
TEN00726	3855411	0,94	SX DRIVE



ZN	R.O. OEM	KG (kg)	MOTORES ENGINES MOTORI
TEN00707	832598	0,93	250, 270, 275, 280, 285



ZN	R.O. OEM	KG (kg)	MOTORES ENGINES MOTORI
TEN00727	3852970	0,16	SX DRIVE



ZN	R.O. OEM	KG (kg)	MOTORES ENGINES MOTORI
TEN00709	832934	0,63	TRIM 270



ZN	R.O. OEM	KG (kg)	MOTORES ENGINES MOTORI
TEN00710	852018	0,18	110, 120, S-B, S-C



ZN	R.O. OEM	KG (kg)	MOTORES ENGINES MOTORI
TEN00711	852018	0,63	S. DRIVE



ZN	R.O. OEM	KG (kg)	MOTORES ENGINES MOTORI
TEN00736	852019	0,04	SAIL DRIVE 100



ZN	R.O. OEM	KG (KG)	MOTORES ENGINES MOTORI
TEN00734	3888305 3888306	1,46	SAIL DRIVE SD 130 - 150 (2002-03)

**TECNOSEAL**  
save your dreams



ZN	R.O. OEM	KG (KG)
TEN00729		0,05

**TECNOSEAL**  
save your dreams



ZN	R.O. OEM	KG (KG)
TEN00731	41100098	0,06

**TECNOSEAL**  
save your dreams



ZN	R.O. OEM	KG (KG)
TEN00732	4100276	0,09

**TECNOSEAL**  
save your dreams



ZN	R.O. OEM	KG (KG)	MOTORES ENGINES MOTORI
TEN00733	3588746 3588748 3588750	0,85	DPH DPR

**TECNOSEAL**  
save your dreams



ZN	R.O. OEM	KG (KG)	MOTORES ENGINES MOTORI
TEN00733/1		0,82	DPH DPR

**TECNOSEAL**  
save your dreams



ZN	R.O. OEM	KG (KG)	MOTORES ENGINES MOTORI
TEN00733BIS	3888814	1,27	SXA DPS-A

**TECNOSEAL**  
save your dreams



ZN	R.O. OEM	Ø EXT	KG (KG)	MOTORES ENGINES MOTORI
TEN00728	3858399	83 mm	0,30	SAIL DRIVE
TEN00728BIS	3584442	97,5 mm	0,28	

Hélice plegable 3 y 4 palas  
Folding propeller 3 & 4 blades.  
Elica a 3 o 4 pale

**TECNOSEAL**  
save your dreams



ZN	R.O. OEM	KG (KG)	MOTORES ENGINES MOTORI
TEN00737	3888817	1,15	SXA APS-A

**TECNOSEAL**  
save your dreams



ZN	R.O. OEM	KG (KG)	MOTORES ENGINES MOTORI
TEN00738	3599981	0,74	IPS

**TECNOSEAL**  
save your dreams



AL	R.O. OEM	KG (KG)	MOTORES ENGINES MOTORI
TEN00739AL	40005875	1,60	IPS

**TECNOSEAL**  
save your dreams



AL	R.O. OEM	KG (KG)	MOTORES ENGINES MOTORI
TEN00742	3861634	0,30	XDP-B

**TECNOSEAL**  
save your dreams



AL	R.O. OEM	KG (KG)	MOTORES ENGINES MOTORI
TEN00743	3861636	0,24	XDP-B

**TECNOSEAL**  
save your dreams



AL	R.O. OEM	KG (KG)	MOTORES ENGINES MOTORI
TEN00744	3807400	0,43	DPH - DPR

**TECNOSEAL**  
save your dreams



AL	R.O. OEM	(KG)	MOTORES ENGINES MOTORI
TEN00735	3888814	0,52	DUO PROP



ZN	R.O. OEM	(KG)	MOTORES ENGINES MOTORI
TEN00715	838929	0,02	



l (mm)	l1 (mm)	Ø (mm)	Ø3 (mm)
13	10	16	5/16"

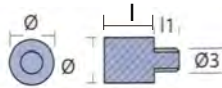

AL	R.O. OEM	Ø	(KG)	MOTORES ENGINES MOTORI
TEN00719	833913	25 - 30 mm	0,31	
TEN00720	833915	35 mm	0,28	
TEN00721	828140	40 mm	0,49	



### KITS TECNOSEAL

KIT	ÁNODO ZN ANODO ZN	R.O. OEM	TAPÓN PLUG TAPPO	(KG)	L (mm)	A (mm)	B (mm)	C (mm)	D (mm)	M BSPT	M2	M2 UNIC
TEN00714T	TEN00714	838929	TEN00714TPM	0,08	85	13	30	15	10	1/2"	M8	7/16"
	TEN00714-1		TEN00714TPF	0,04			30				M8	
				0,02			30				M8	
				0,06		13		15		1/2"	M8	
				0,06		13				1/2"		7/16"

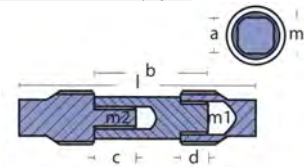

KIT	ÁNODO ZN ANODO ZN	TAPÓN PLUG TAPPO	(KG)	L (mm)	A (mm)	B (mm)	C (mm)	Ø BSPT	Ø	Ø2 UNIC	MOTORES ENGINES MOTORI
TEN00713T	TEN00713	TEN00713TP	0,10	67	13	10	40	1/2"	15	7/16"	200
			0,06				40		15	7/16"	250
			0,40		13	10		1/2"			270

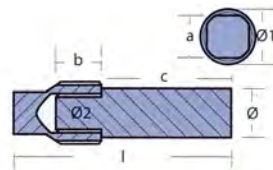
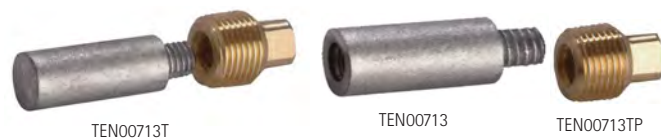

KIT	ÁNODO ZN ANODO ZN	R.O. OEM	TAPÓN PLUG TAPPO	(KG)	A (mm)	Ø1 (mm)	L (mm)	B (mm)	Ø	Ø2	Ø4 UNIC
TEN00716T	TEN00716	823661	TEN00716TP	0,16		10	44	16	25	3/8"	
				0,26		61	19	44	25	3/8"	
				0,10	19	40					

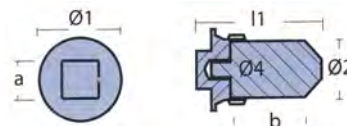

ZN MOTORES ENGINES MOTORI  
TENKITVOLVO280 280

**TECNOSEAL**  
save your dreams

**NEW**

ZN ZINC ANODES  
ANODES EN ZINC • ANODES DE ZINC • ANODES EN ZINC

ZN MOTORES ENGINES MOTORI  
TENKITVOLVODP290 DUO PRO 290

**TECNOSEAL**  
save your dreams

**NEW**

ZN ZINC ANODES  
ANODES EN ZINC • ANODES DE ZINC • ANODES EN ZINC

ZN MOTORES ENGINES MOTORI  
TENKITVOLVO290 290

**TECNOSEAL**  
save your dreams

**NEW**

ZN ZINC ANODES  
ANODES EN ZINC • ANODES DE ZINC • ANODES EN ZINC

ZN MOTORES ENGINES MOTORI  
TENKITVOLVODP290-C DUO PRO 290-C

**TECNOSEAL**  
save your dreams

**NEW**

ZN ZINC ANODES  
ANODES EN ZINC • ANODES DE ZINC • ANODES EN ZINC

ZN MOTORES ENGINES MOTORI  
TENKITVOLVO290-C 290

**TECNOSEAL**  
save your dreams

**NEW**

ZN ZINC ANODES  
ANODES EN ZINC • ANODES DE ZINC • ANODES EN ZINC

ZN MOTORES ENGINES MOTORI  
TENKITVOLVODPH/DPH DPH/DPH

**TECNOSEAL**  
save your dreams

**NEW**

ZN ZINC ANODES  
ANODES EN ZINC • ANODES DE ZINC • ANODES EN ZINC

MG MOTORES ENGINES MOTORI  
TENKITVOLVO290-MG-C 290

**TECNOSEAL**  
save your dreams

**NEW**

MG MAGNESIUM ANODES  
ANODES EN MAGNESIO • ANODES DE MAGNESIO • ANODES EN MAGNESIO

ZN MOTORES ENGINES MOTORI  
TENKITVOLVOELICA3PAL ELICA 3 PALE

**TECNOSEAL**  
save your dreams

**NEW**

ZN ZINC ANODES  
ANODES EN ZINC • ANODES DE ZINC • ANODES EN ZINC

ZN MOTORES ENGINES MOTORI  
TENKITVOLVODP280 DUO PRO 280

**TECNOSEAL**  
save your dreams

**NEW**

ZN ZINC ANODES  
ANODES EN ZINC • ANODES DE ZINC • ANODES EN ZINC

ZN MOTORES ENGINES MOTORI  
TENKITVOLVOIPS IPS

**TECNOSEAL**  
save your dreams

**NEW**

ZN ZINC ANODES  
ANODES EN ZINC • ANODES DE ZINC • ANODES EN ZINC



ZN	MOTORES ENGINES MOTORI	
TENKITVOLVOSX	SX	
		

ZN	MOTORES ENGINES MOTORI	
TENKITVOLVOXDP-B	XDP-B	
		

ZN	MOTORES ENGINES MOTORI	
TENKITVOLVOSXA/DPASA	SXA / DPASA	
		



**CANADA METAL**

ZN		AL		R.O. OEM	MOTORES ENGINES MOTORI
CM875812	0,92	CM875812A	0,41	875812	110S



ZN		AL		R.O. OEM	MOTORES ENGINES MOTORI
CM852835	0,76	CM852835A	0,30	852835	SP, DP



ZN		AL		R.O. OEM	MOTORES ENGINES MOTORI
CM851983	0,49	CM851983A	0,24	876286	110S, 120S, SB, M525S



ZN		AL		R.O. OEM	MOTORES ENGINES MOTORI
CM872793	0,11	CM872793A	0,05	872793	SP, DP



ZN		AL		R.O. OEM	MOTORES ENGINES MOTORI
CM3888305	1,48	CM3888305A	0,20	3888305	130S, 150S



ZN		AL		R.O. OEM	MOTORES ENGINES MOTORI
CMV-15	0,20			875810	50, 100





ZN		AL		R.O. OEM	MOTORES ENGINES MOTORI
CM855105	0,16			855105	50S





ZN		AL		R.O. OEM	MOTORES ENGINES MOTORI
CMV-16	0,20			875809	50, 200





ZN	 (kg)	AL	 (kg)	R.O. OEM	MOTORES ENGINES MOTORI
CMV-17	0,29	CMV-17A	0,13	875805	AQ250, 270, 270T, 275, 275A SP-A/MT, A1, A2 SPC





ZN	 (kg)	AL	 (kg)	R.O. OEM	MOTORES ENGINES MOTORI
CMCMV-18	0,73	CMCMV-18A	0,29	875815	AQ280, L, T, PT AQ285A, 290, 290A SP-A





ZN	R.O. OEM	 (kg)	AL	R.O. OEM	 (kg)	MOTORES ENGINES MOTORI
CM3841427	3888817	0,43	CM3841427A	3888816	0,20	SX-A, DPS-A, B FWD





ZN	R.O. OEM	 (kg)	AL	R.O. OEM	 (kg)	MOTORES ENGINES MOTORI
CM3883728	3888814	1,08	CM3883728A	3888813	0,20	SX-A, DPS-A, B FWD





ZN	 (kg)	AL	 (kg)	R.O. OEM	MOTORES ENGINES MOTORI
CM3852970	0,15	CM3852970A	0,07	3852970	SX-C





ZN	 (kg)	AL	 (kg)	R.O. OEM	MOTORES ENGINES MOTORI
CM873395	0,28	CM873395A	0,13	873395	SX-MHP





ZN	 (kg)	AL	 (kg)	R.O. OEM	MOTORES ENGINES MOTORI
CM3855411	1,04	CM3855411A	0,41	3855411	SX, DPS





ZN	 (kg)	AL	 (kg)	R.O. OEM	MOTORES ENGINES MOTORI
CM3854130	1,09	CM3854130A	0,41	3854130	SX, SXA, DPS





ZN	 (kg)	AL	 (kg)	R.O. OEM	MOTORES ENGINES MOTORI
CM875821	0,92	CM875821A	0,41	875821	DUOPROP, DP-A, A1, A2, B1, C, D AQ280DP, 290DP



ZN	 (kg)	AL	 (kg)	R.O. OEM	MOTORES ENGINES MOTORI
CM832598	0,95	CM832598A	0,37	832598	AQ250, 270, 275, 280, 280DP, 280DPT SP-A/MT



ZN	 (kg)	AL	 (kg)	R.O. OEM	MOTORES ENGINES MOTORI
CM872139	0,65	CM872139A	0,29	872139	DPX





ZN	 (kg)	AL	 (kg)	R.O. OEM	MOTORES ENGINES MOTORI
CM876638	0,04			876638	DPX



ZN	 (kg)	AL	 (kg)	R.O. OEM	MOTORES ENGINES MOTORI
CM3861634	0,29	CM3861634A	0,13	3861634	XDP



ZN	 (kg)	AL	 (kg)	R.O. OEM	MOTORES ENGINES MOTORI
CM3861636	0,24	CM3861636A	0,10	3861636	XDP



ZN	KG (kg)	AL	KG (kg)	R.O. OEM	MOTORES ENGINES MOTORI
CM832934	0,66			832934	270



ZN	KG (kg)	AL	KG (kg)	R.O. OEM	MOTORES ENGINES MOTORI
CM838929	0,05	CM838929A	0,02	838929	



ZN	KG (kg)	AL	KG (kg)	R.O. OEM	MOTORES ENGINES MOTORI
CM3593881	0,69	CM3593881A	0,29	3593981	IPS



ZN	KG (kg)	AL	KG (kg)	R.O. OEM	MOTORES ENGINES MOTORI
CM40005875	3,61	CM40005875A	1,51	40005875	IPS



ZN	KG (kg)	AL	KG (kg)	R.O. OEM	MOTORES ENGINES MOTORI
CM852019	1,09			8520219	



ZN	KG (kg)	AL	KG (kg)	R.O. OEM	MOTORES ENGINES MOTORI
CM823661	0,14	CM823661A	0,07	823661	



ZN	KG (kg)	AL	KG (kg)	R.O. OEM	MOTORES ENGINES MOTORI
CM3588746	0,71	CM3588746A	0,35	3588746	DPH

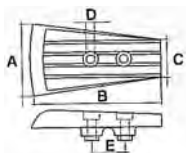

A	B	C	D	E
(mm)	(mm)	(mm)	(mm)	(mm)
78	130	49	8,5	35

ZN	KG (kg)	AL	KG (kg)	R.O. OEM	MOTORES ENGINES MOTORI
CM3588745	0,49	CM3588745A	0,20	3588745	DPH, DPR

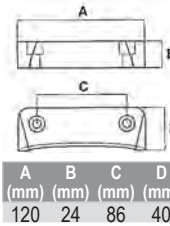

ZN	KG (kg)	R.O. OEM	ROSCA THREAD FILETTO
CM873411	0,30	873411	22 - 25 mm
CM873412	0,28	873412	30 mm
CM828140	0,54	873413	40 - 45 mm



ZN	KG (kg)	R.O. OEM	MOTORES ENGINES MOTORI
CM41100276	0,09	41100276	



27 mm

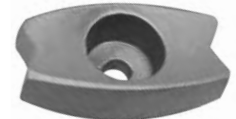

52 mm

ZN	KG (kg)	R.O. OEM	MOTORES ENGINES MOTORI
CM41100098	0,06	41100098	



ZN	KG (kg)	R.O. OEM	MOTORES ENGINES MOTORI
CM41100276P	0,04	41100276	

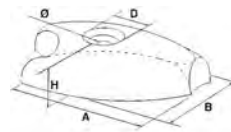

A	B	H	D	Ø
(mm)	(mm)	(mm)	(mm)	(mm)
37	22	15	10	6,5



ZN	KG (kg)	AL	KG (kg)	R.O. OEM	MOTORES ENGINES MOTORI
CM852018	0,05	CM852018A	0,03	852018	



# KITS CANADA METAL

ZN	AL	R.O. OEM	MOTORES ENGINES MOTORI
CM3858399	CM3858399A	3858399	3 PALAS 3 BLADES 3 PALE

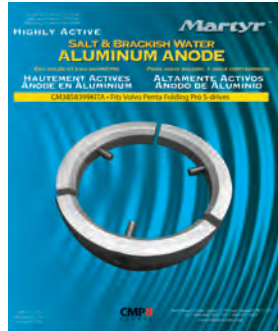

AL	MG	MOTORES ENGINES MOTORI
CM290DPKITA	CM290DPKITM	290 DP

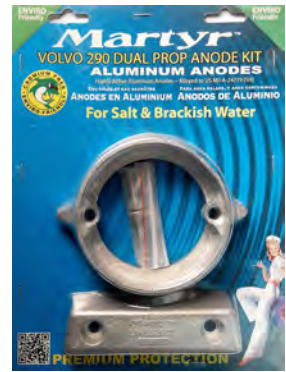

AL	MG	MOTORES ENGINES MOTORI
CM280KITA	CM280KITM	280 SP



AL	MG	MOTORES ENGINES MOTORI
CMSXKITA	CMSXKITM	SX



AL	MG	MOTORES ENGINES MOTORI
CM290KITA	CM290KITM	290 SP

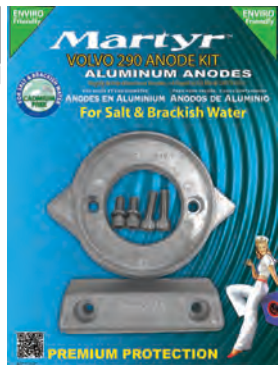

AL	MG	MOTORES ENGINES MOTORI
CMSXAKITA	CMSXAKITM	SX-A



AL	MG	MOTORES ENGINES MOTORI
CM280DPKITA	CM280DPKITM	280 DP



AL	MG	MOTORES ENGINES MOTORI
CMDPHKITA	CMDPHKITM	DPH

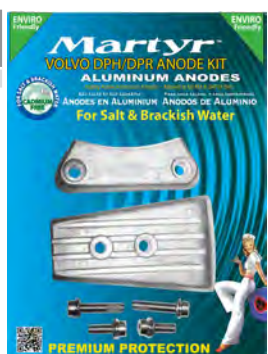

# CORREAS Y COMPONENTES BELTS & COMPONENTS CINGHIE E COMPONENTI

## PIÑÓN CIGÜEÑAL CRANKSHAFT GEAR PIGNONE ALBERO MOTORE

Ref.	R.O. OEM
RM855428	855428

**MOTORES / ENGINES / MOTORI**  
AQ125A  
AQ131A, B, C, D  
AQ145B  
AQ151A, B, C  
230, 250



## PIÑÓN ARBOL DE LEVAS CAMSHAFT GEAR PIGNONE ASSE A CAMME

Ref.	R.O. OEM
RM856239	856239 855473 831972

**MOTORES / ENGINES / MOTORI**  
AQ125A  
AQ131 A, B, C, D  
AQ145B  
AQ151 A, B, C  
230, 250  
Utilizan 2 unidades  
2 pieces required  
Quantità necessaria n2



## CORREA DISTRIBUCIÓN TIMING BELT CINGHIA DISTRIBUZIONE

Ref.	R.O. OEM
REC463377	463377

**MOTORES / ENGINES / MOTORI**  
AQ120B  
AQ125A  
AQ131A, B, C, D  
AQ140A  
AQ145A, B  
AQ151A, B, C  
230A, B  
250A, B



Ref.	R.O. OEM
REC855506	855506

**MOTORES / ENGINES / MOTORI**  
251A  
AQ71 A, B, C  
B25



## TAPÓN SEGURIDAD TAPA DE CORREAS PLUG SAFETY COVER BELTS TAPPO SICUREZZA COPERCHIO CINGHIE

Ref.	R.O. OEM
REC861019	861019

**MOTORES / ENGINES / MOTORI**  
KAD32, 42, 43, 44, 300



## KIT DISTRIBUCIÓN TIMING BELT KIT KIT DISTRIBUZIONE

Ref.	R.O. OEM
REC31359568	31359568 31258305 30731772

**MOTORES / ENGINES / MOTORI**  
D3-110I-A, I-B, I-C, I-D, I-E, I-F  
D3-130A-A, A-B, A-C, I-A, I-B, I-C  
D3-140A-E, A-F, I-E, I-F, A-D  
D3-150I-D, I-E, I-F  
D3-160A-A, A-B, A-C, I-A, I-B, I-C  
D3-190A-B, A-C, I-B, I-C  
D3-170I-D, I-E, I-F, A-D, A-E, A-F  
D3-200I-D, I-E, I-F, A-D, A-E, A-F  
D3-220A-D, A-E, A-F, I-D, I-E, I-F



## TENSOR Y POLEAS CORREA SERPENTIN TENSIONER & PULLEY TENDICINGHIA E PULLEGIA CINGHIA SERPENTINA

**RODILLO TENSOR  
TENSION ROLLER  
TENDICINGHIA**

Ref.	R.O. OEM	
REC3582324	3582324	Ø 95 mm

**MOTORES / ENGINES / MOTORI**  
KAD32, 43, 44, 300  
KAMD43, 44, 300  
TAMD42WJ-A



Ref.	R.O. OEM
RM3885250	3885250 3587858 3587859 3861010

**MOTORES / ENGINES / MOTORI**  
4.3 GL, GXI, GI, OSI  
5.0 GXI, GI, OSI  
5.7 GI, GXI, OSI  
8.1 GI, GXI, IPSCE, OSI



**POLEA RUPTURA  
RUPTURE PULLEY  
PULEGIA**

Ref.	R.O. OEM	TENSOR TENSIONER TENDICINGHIA
REC21585053	21585053	RM3885250

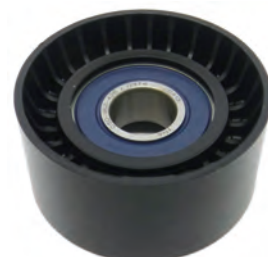

Ref.	R.O. OEM
REC861563	861563

**MOTORES / ENGINES / MOTORI**  
KAD32P-A, 43, 44, 300  
KAMD43, 44, 300  
TAMD42WJ-A



Ref.	R.O. OEM
REC3860079	3860079

**MOTORES / ENGINES / MOTORI**  
4.3 GI, GSI, GXI, OS  
5.0 GI, GSI, GXI  
5.7 GI, GXI, OS  
7.4 GI, GSI  
Se instala bajo el alternador  
It is installed under the alternator  
È installato sotto l'alternatore



**TENSOR CORREA ALTERNADOR D4/D6**  
**ALTERNATOR BELT TENSIONER D4/D6**  
**TENDICINGHIA ALTERNATORE D4/D6**

Ref.	R.O. OEM
REC22774756	22774756
	21344508
	3582694
	3583665

**MOTORES / ENGINES / MOTORI**  
D4-180, 225, 260, 300, 310  
D6-280, 300, 310, 330, 370, 400, 435



**TENSOR CORREA COMPRESOR D4/D6**  
**COMPRESSOR BELT TENSIONER D4/D6**  
**TENDICINGHIA COMPRESSORE D4/D6**

Ref.	R.O. OEM
REC22171036	22171036
	21786692
	3847481
	3883784
	3588305
	3582692

**MOTORES / ENGINES / MOTORI**  
D4-260, 300  
D6-350, 370, 400, 435



**POLEA COMPRESOR ALTERNADOR**  
**ALTERNATOR COMPRESSOR PULLEY**  
**PULEGGIA ALTERNATORE**

Ref.	R.O. OEM
REC21280913	21280913
	3848896
	3809465
	3883786
	21172053

**MOTORES / ENGINES / MOTORI**  
D4-260, 300 (SN -2004017297)  
D6-350, 370, 400, 435 (SN -2006032252)

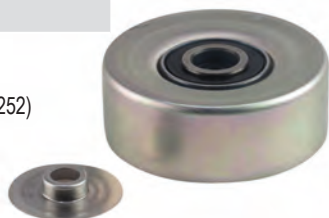

Ref.	R.O. OEM
REC3847482	3847482

**MOTORES / ENGINES / MOTORI**  
D4-260, 300 (SN 2004017298+)  
D6-350, 370, 400, 435 (SN 2006032252+)



Ref.	R.O. OEM
REC31251252	31251252
	30757056
	30637961

**MOTORES / ENGINES / MOTORI**  
D3-110I-A, I-B, I-C  
D3-130A-A, I-A, A-B, I-B, A-C, I-C  
D3-160A-A, I-A, A-B, I-B, A-C, I-C  
D3-190A-B, I-B, A-C, I-C



**TENSIÓMETRO DISTRIBUCIÓN**  
**TENSIONER**  
**TENDICINGHIA DISTRIBUZIONE**

Ref.	R.O. OEM
REC855507	855507

**MOTORES / ENGINES / MOTORI**  
AQ171 A, C  
251A  
KAD42A  
KAMD42A  
KAD42B, KAMD42B (Para compresor / For  
compressor / per compressore: -2204208023)



Ref.	R.O. OEM
REC831986	831986

**MOTORES / ENGINES / MOTORI**  
AQ120B, 125, 131, 140, 145, 151, 230A,  
250A, 250B



**GUÍA CORREAS SERPENTÍN Y TENSORES  
SERPENTINE BELTS & TENSIONERS GUIDE  
GUIDA CINGHIE SERPENTINA E TENDICINCHIA**



Modelo Model Modello	SERPENTIN SERPENTINE SERPENTINA	TENSOR TENSIONER TENDICINCHIA
3.0GLM-C	RM3586324	
3.0GLP-C, -D	RM3586325	
3.0GLP-J, -N	REC3888177	
3.0GXJ-J	REC21132392	
3.0GXIC-J	REC21132392	
4.3GIPEFS	REC3860086	REC3860079
4.3GL-G, -GF	RM3889124	RM3885250
4.3GL-J, -JF	RM21132390	RM3885250
4.3GL-P	RM21399021	RM3885250
4.3GXJ-A, -B, -BF, -C, -CF, -D, -DF	REC3860086	REC3860079
4.3GXJ-E, -EF	RM3586326	REC3860079
4.3GXJ-F, -FF, -G, -GF	RM3889124	RM3885250
4.3GXJ-P, -Q	RM21399021	RM3885250
4.3GXJ-E-P, -Q	RM21399021	RM3885250
4.3GXJ-225-R, GXJ-225-R	RM21399021	RM3885250
4.3GXJ-E-J, -JF, -M	RM21132390	RM3885250
4.3GI-200-R	RM21399021	RM3885250
4.3OSJ-J, -JF	RM21132390	RM3885250
4.3OSJ-B, -BF, -C, -CF, -D, -DF	REC3860086	REC3860079
4.3OSJ-E, -EF	RM3586326	REC3860079
4.3OSJ-G, -GF	RM3889124	RM3885250
V6-200-A, -225-A, -225-E-A	RM21399021	RM3885250
5.0GIPEFS, GSIPEFS	REC3860086	REC3860079
5.0GL-H, -HF	RM3889124	RM3885250
5.0GL-J, -JF	RM21132390	RM3885250
5.0GIC-J, -JF	RM21132390	RM3885250
5.0GICE-J, -JF, -M, -MF	RM21132390	RM3885250
5.0GXJ-A, -B, -BF, -C, -CF, -D, -DF	REC3860086	REC3860079
5.0GIC-225-S, GICE-225-S	RM21399021	RM3885250
5.0GXJ-E-270-R	RM21399021	RM3885250
5.0GXIC-270-R	RM21399021	RM3885250
5.0GXJ-270-R	RM21399021	RM3885250
5.0GXICE-270-R	RM21399021	RM3885250
5.0GXICE-J, -JF, -M, -MF	RM21132390	RM3885250
5.0GXICE-P	RM21399021	RM3885250
5.0GXIC-J, -JF	RM21132390	RM3885250
5.0GXIC-P	RM21399021	RM3885250
5.0GXJ-E, -EF	RM3586326	REC3860079
5.0GXJ-E-J, -JF, -K, -KF, -M, -MF, -N	RM21132390	RM3885250
5.0GXJ-E-P	RM21399021	RM3885250
5.0GXJ-F, -FF, -G, -GF	RM3889124	RM3885250
5.0GXJ-J, -JF, -N	RM21132390	RM3885250
5.0GXJ-P	RM21399021	RM3885250
5.0OSJ-B, -C, -CF, -D, -DF	REC3860086	REC3860079
5.0OSJ-E, -EF	RM3586326	REC3860079
5.0OSJ-E-J, -JF	RM21132390	RM3885250
5.0OSJ-F, -FF, -G, -GF	RM3889124	RM3885250
5.0OSJ-J, -JF	RM21132390	RM3885250
5.7GI-300-J, -JF, -N	RM21132390	RM3885250
5.7GI-300-P, -300-R	RM21399021	RM3885250
5.7GI-A, -B, -BF, -C, -CF	REC3860086	REC3860079
5.7GIC-300-R	RM21399021	RM3885250
5.7GIC-300-J, -JF	RM21132390	RM3885250
5.7GIC-300-P, -300-R	RM21399021	RM3885250
5.7GICE-300-J, -JF, -M, -MF	RM21132390	RM3885250
5.7GICE-300-P, -300-R	RM21399021	RM3885250
5.7GI-A, -D, -DF	REC3860086	REC3860079
5.7GI-E, -EF	RM3586326	REC3860079
5.7GIE-300-J, -JF, -K, -KF, -M, -MF, -N	RM21132390	RM3885250

Modelo Model Modello	SERPENTIN SERPENTINE SERPENTINA	TENSOR TENSIONER TENDICINCHIA
5.7GiE-300-P, -300-R	RM21399021	RM3885250
5.7GI-F, -FF, -G, -GF	RM3889124	RM3885250
5.7GIL-A, -B, -C, -D	RM3861500	REC3860079
5.7GSIL-A	RM3861500	REC3860079
5.7GSIPEFS	REC3860086	REC3860079
5.7GXJ-A, -B, -C, -CF, -D, -DF, -E, -EF	REC3860086	REC3860079
5.7GXJ-320-R, GXJ-320-R	RM21399021	RM3885250
5.7GXIC-320-R, GXICE-320-R	RM21399021	RM3885250
5.7GXICE-J, -JF, -M, -MF	RM21132390	RM3885250
5.7GXIC-J, -JF	RM21132390	RM3885250
5.7GXICE-P	RM21399021	RM3885250
5.7GXIC-JF	RM21132390	RM3885250
5.7GXIC-P	RM21399021	RM3885250
5.7GXJ-E, -JF, -K, -KF, -M, -MF, -N	RM21132390	RM3885250
5.7GXJ-E-P	RM21399021	RM3885250
5.7GXJ-F, -FF	RM3586326	REC3860079
5.7GXJ-G, -GF, -H, -HF	RM3889124	RM3885250
5.7GXJ-J, -JF	RM21132390	RM3885250
5.7GXJ-L, -B, -C, -D, -E	RM3861500	REC3860079
5.7GXJ-N	RM21399021	RM3885250
5.7GXJ-P	RM21132390	RM3885250
5.7OSJ-300-J, -JF	RM21132390	RM3885250
5.7OSJ-A, -AF, -B, -BF, -C, -CF	REC3860086	REC3860079
5.7OSJ-D, -DF	RM3586326	REC3860079
5.7OSJ-G, -GF, -E, -EF	RM3889124	RM3885250
5.7OSXJ-A, AF, B, -BF, -C, -CF	REC3860086	REC3860079
5.7OSXJ-D, -DF	RM3586326	REC3860079
5.7OSXJ-E, -JF	RM21132390	RM3885250
5.7OSXJ-E, -EF, -G, -GF	RM3889124	RM3885250
5.7SI-C, -CF	REC3860086	REC3860079
5.7OSJ-E-300-J, -JF	RM21132390	RM3885250
5.7SXJ-B	REC3860086	REC3860079
5.7SXJ-J, -JF	RM21132390	RM3885250
V8-225-C-A, -CE-A, -C-B, -CE-B	RM21399021	RM3885250
V8-270-A, B, -E, -A, -C-A, -CE, -A, -E, -B, -C, -B, -CE, -B	RM21399021	RM3885250
V8-300-A, B, -E, -A, -C-A, -CE, -A, -E, B, -C, -B, -CE, -B	RM21399021	RM3885250
V8-320-A, B, -E, -A, -C-A, -CE, -A, -E, -B, -C, -B, -CE, -B	RM21399021	RM3885250
8.1GIC-400-Q, -J, -JF	RM21132385	RM3885250
8.1GICE-400-J, -JF	RM21132385	RM3885250
8.1GICE-M, -MF, -P, -Q	RM21132385	RM3885250
8.1GIE-J, -JF, -K, -KF, -M, -MF, -P	RM21132385	RM3885250
8.1GI-A, -B, -BF, -H, -HF, -G, -GF	RM21132390	RM3885250
8.1GI-J, -JF	RM21132385	RM3885250
8.1GIL-H	RM3889127	RM3885250
8.1GSI-A	RM21132390	RM3885250
8.1GXJ-E, -JF, -K, -KF, -M, -MF, -P	RM21132385	RM3885250
8.1GXJ-A, -AF, -G, -GF, -F, -FF	RM21132390	RM3885250
8.1GXJ-J, -JF	RM21132385	RM3885250
8.1GXJ-L-G	RM3889127	RM3885250
8.1IPSE-JF, -MF, -PF, -Q	RM3861501	RM3885250
8.1IPSE-JF	RM21132385	RM3885250
8.1OSJ-C, -CF, -D, -DF	RM21132390	RM3885250
8.1OSJ-E, -JF	RM21132385	RM3885250
8.1OSJ-J, -JF	RM21132385	RM3885250

# GUÍA CORREAS SERPENTÍN Y TENSORES SERPENTINE BELTS & TENSIONERS GUIDE GUIDA CINGHIE SERPENTINA E TENDICINCHIA



Modelo Model Modello	SERPENTIN SERPENTINE SERPENTINA	TENSOR TENSIONER TENDICINCHIA	Ø RODILLO TENSOR TENSIONER ROLLER Ø Ø RULLO TENDICINCHIA
D3-110I-A	RM30731809	REC31251252	
D3-110I-B	RM30731809	REC31251252	
D3-110I-C	RM30731809	REC31251252	
D3-110I-D	RM30731809	REC31251252	
D3-130A-A	RM30731809	REC31251252	
D3-130A-B	RM30731809	REC31251252	
D3-130A-C	RM30731809	REC31251252	
D3-130I-A	RM30731809	REC31251252	
D3-130I-B	RM30731809	REC31251252	
D3-130I-C	RM30731809	REC31251252	
D3-140A-D	RM30731809	REC31251252	
D3-150I-D	RM30731809	REC31251252	
D3-160A-A	RM30731809	REC31251252	
D3-160A-B	RM30731809	REC31251252	
D3-160A-C	RM30731809	REC31251252	
D3-160I-A	RM30731809	REC31251252	
D3-160I-B	RM30731809	REC31251252	
D3-160I-C	RM30731809	REC31251252	
D3-170A-D	RM30731809	REC31251252	
D3-170I-D	RM30731809	REC31251252	
D3-190A-B	RM30731809	REC31251252	
D3-190A-C	RM30731809	REC31251252	
D3-190I-B	RM30731809	REC31251252	
D3-190I-C	RM30731809	REC31251252	
D3-200A-D	RM30731809	REC31251252	
D3-200I-D	RM30731809	REC31251252	
D3-220A-D	RM30731809	REC31251252	
D3-220I-D	RM30731809	REC31251252	
D4 (con / with / con DH)	REC21407028	REC22774756	
D4 (no / not / no DH)	RM21405494	REC22774756	

Modelo Model Modello	SERPENTIN SERPENTINE SERPENTINA	TENSOR TENSIONER TENDICINCHIA	Ø RODILLO TENSOR TENSIONER ROLLER Ø Ø RULLO TENDICINCHIA
D6 (con / with / con DH)	REC21407028	REC22774756	
D6 (no / not / no DH)	RM21405494	REC22774756	
KAD300	RM3582424	REC3582324	95 mm
KAD300A	RM3582424	REC3582324	95 mm
KAD32P-A	RM3582424	REC3582324	95 mm
KAD32P-A	REC861564	REC861563	
KAD43P-A	RM3582424	REC3582324	95 mm
KAD43P-A	REC861564	REC861563	
KAD44P-B	RM3582424	REC3582324	95 mm
KAD44P-B	REC861564	REC861563	
KAD44P-C	RM3582424	REC3582324	95 mm
KAD44P-C	REC861564	REC861563	
KAMD300	RM3582424	REC3582324	95 mm
KAMD300	REC861564	REC861563	
KAMD300-A	RM3582424	REC3582324	95 mm
KAMD300-A	REC861564	REC861563	
KAMD44P	RM3582424	REC3582324	95 mm
KAMD44P	REC861564	REC861563	
KAMD44P-A	RM3582424	REC3582324	95 mm
KAMD44P-A	REC861564	REC861563	
KAMD44P-B	RM3582424	REC3582324	95 mm
KAMD44P-B	REC861564	REC861563	
KAMD44P-C	RM3582424	REC3582324	95 mm
KAMD44P-C	REC861564	REC861563	
D9A2A MH/MP/MG (425/500/575)	REC1066823		
D9A2A MH/MP/ MG (425/500/575) SN7009156811+	REC982570		
D11A, B	REC982570		
D12D/C (-A, -B, -C, -D, -E, -F, -G, -H)	REC978217		

# GUÍA CORREAS V-BELTS GUIDE GUIDA CINGHIE



Modelo Model Modello		REF	R.O. OEM
AQ60F, 90, 95, 95A, 100, 105A, 110, 115, 115A, 115B, 120, 125, 130, 130A BB115, A	Alt	REC966891	966891
AQ120A, B AQ125A, B AQ140A AQ145A	Alt	REC966694	966694
AQ130B, C, D	Alt	REC966891	966891
	BA WP & Alt	REC966382	966382
AQ131A, B, C, D	Distribución Camshaft Distribuzione	REC463377	463377
	BA WP & Alt	REC966382	966382
AQ145B	Distribución Camshaft Distribuzione	REC463377	463377
	BA WP & Alt	REC966382	966382
AQ151A, B, C 2.5L AQ152 Gasolina	Distribución Camshaft Distribuzione	REC463377	463377
	BA WP & Alt	REC966694	966694
AQ165A, B, C AQ170A, B, C	BA WP & Alt	REC966694	966694
	BA WP & Alt	REC966382	966382
AQ171A, C	Distribución Camshaft Distribuzione	REC855506	855506
AQ175A	BA WP & Alt	REC978750	978750

Modelo Model Modello		REF	R.O. OEM
	BA WP & Alt	REC978750	978750
AQ200B, C AQ307 GM Gasolina	BA salada Sea WP PA salada Ne servono 2)	GDY17291 (necesita 2 need 2 Ne servono 2)	967158
	BA WP & Alt	REC978750	978750
AQ200D, F AQ225A, B, C, D, E, F	BA salada Sea WP PA salada Ne servono 2)	GDY17291 (necesita 2 need 2 Ne servono 2)	967158
	DH PS	REC967111	967111
AQ205A	BA WP & Alt	REC978750	978750
AQ211A AQ231A, B	DH PS	REC967111	967111
	BA WP & Alt	REC978750	978750
AQ255A, B AQ260A, B AQ271A, B, C, D AQ280A AQ290A AQ311A, B	BA salada Sea WP PA salada Ne servono 2)	GDY17291 (necesita 2 need 2 Ne servono 2)	967158
	BA WP & Alt	REC966382	966382
230A, 250, 251	Distribución Camshaft Distribuzione	REC463377	463377
	DH PS	REC967111	967111
431	BA WP & Alt	REC978750	978750
	BA WP & Alt	REC978750	978750
501A, B 570A, 572A	BA - DH WP - PS	REC967111	967111
740A, B	BA WP & Alt	RM967191	967191



Modelo Model Modello		REF	R.O. OEM
AQ271A, B, C, D	BA WP & Alt	REC978750	978750
AQ311A, B 5.7L (V-8 350)	BA - DH WP - PS	REC967111	967111
3.0GL - 3.0GS (MD, HU, LC, LK, BY, WT)	BA - WP	GDY15356	3850268
	Alt & DH Alt & PS	REC3853536	3853536
	Alt	REC3852106	
3.0GLP-A 3.0GSP-A, P-B, P-C	Alt & DH - Alt & PS	REC3860092	3860092
	Alt	RM3860093	3860093
	DH <b>NEW</b>	REC3857835	3857835
4.3 GL 4.3 GS	BA - WP	REC3852106	
	Alt & DH Alt & PS	REC3852464	3852464
	Alt	RM3852504	3852504
4.3 Gi	BA - WP	REC3852106	
	Alt & DH Alt & PS	REC3852464	3852464
5.0 FL	BA - WP	GDY15382	3852348
	Alt & DH Alt & PS	REC3858462	3858462
	Alt	REC3852106	3852106
5.0 Fi	BA - WP	GDY15382	3852348
	Alt & DH Alt & PS	REC3858462	3858462
	HD <b>NEW</b>	REC3857835	3857835
	Alt	REC3852106	

Modelo Model Modello		REF	R.O. OEM
5.0 GL, BY	BA - WP	GDY15295	978457
BY, PJX, WT, EF	Alt & DH Alt & PS	REC3852464	3852464
5.7 GL MD, HU, NC	BA - WP	REC3852106	3852336
BY, WT, EF	Alt & DH Alt & PS	REC3852464	3852464
7.4Gi, GL, Gsi (PNCA, PNCM)	BA - WP	RM3850430	3850430
7.4Gi, GL, Gsi (LK, BY, INCCE, PNCB)	BA - WP	RM978454	978454
7.4Gi, GL, Gsi (BY, WT, MD, HU, NC, LK)	Alt	RM3854643	3854643
	BA, Alt & DH WP, Alt & PS	RM3860087	3860087
7.4 GL (MD, HU, NC, LK)	Alt	RM3852607	3852607
8.1 Gi, Gsi	BA, Alt & DH WP, Alt & PS	RM21132390	3861034
8.2GL, Gsi	Alt	RM3852607	3852607
8.2GL, Gsi (LK, BY, WT)	BA - WP	RM978454	978454
	Alt	RM3854643	3854643
8.2GL, Gsi (PNCA, PNCM)	BA - WP	RM3850430	3850430
8.2 Gsi (EF)	BA, Alt & DH WP, Alt & PS	RM3860087	3860087

**GUÍA CORREAS  
V-BELTS GUIDE  
GUIDA CINGHIE**



Modelo Model Modello		REF	R.O. OEM
MD1 (-M011131)	BA WP & Alt	REC57-96834Q	952141
MD1 (M011131+)	BA WP & Alt	REC966990 (necesita 2 need 2 Ne servono 2)	966990
MD1B MD2B AQDB	BA & G	REC966990 (necesita 2 need 2 Ne servono 2)	966990
	35-1/2" BA WP & Alt	REC966906	966906
	40-1/2" BA WP & Alt	REC3852106	966916
MD2	BA & G (-M06274)	REC966990 (necesita 2 need 2 Ne servono 2)	966990
	BA WP & Alt (M06275+)	REC966914	966914
	BA WP & Alt	REC3852106	966906
MD5A, B	BA WP & Alt	REC966990	966698
MD5C (-M030016)	BA WP & Alt	REC966990	966698
MD6A (M01234+)	BA & G	REC3858462	966700
MD6B MD7A	BA WP & Alt	REC966931	966931
	BA WP & Alt	REC966933	966933
MD7B	BA WP & Alt	REC966707	966707
MD11C MD11D Sin circuito refrigeración cerrado Without raw water cooling system Circuito refrigerazione aperto	35-1/2" Alt	REC966906	966906
	51" BA WP & Alt	REC966990	966698
	55" BA WP & Alt	REC966931	966931

Modelo Model Modello		REF	R.O. OEM
MD11C MD11D Con circuito refrigeración cerrado With raw water cooling system Circuito refrigerazione chiuso	BA WP & Alt	REC966942	966942
MD17C Sin circuito refrigeración cerrado Without raw water cooling system Circuito refrigerazione aperto	BA WP & Alt	REC966383	966383
MD17C Con circuito refrigeración cerrado With raw water cooling system Circuito refrigerazione chiuso	BA WP & Alt	GDY15545	966929
2001	Alt	REC966903	966903
2002	Alt	REC966900	966900
2003	Alt	REC966906	966906
2003T	Alt	REC966906	966906
MD21A	BA WP & Alt	REC829207	829207
MD21B	BA WP & Alt	REC829207	829207
MD22	BA WP & Alt	RM966912	966912
	WP <b>NEW</b>	REC3580835	3580835
D1-13, 20		RM3809625	3809625
D1-30		RM3812159	3812159
D2-40		RM21314684	21314684
D2-55	Alt	RM967114	967114
D2-75	Alt	RM3584086	3584086
D3	Alt	REC30731809	30731809
	HD <b>NEW</b>	REC22352491	22352491
	Alter adic <b>NEW</b>	REC22283751	22283751
	WP <b>NEW</b>	REC21160912	21160912

Modelo Model Modello		REF	R.O. OEM
D4, 6	Alt	REC3583729	3583729
	Compresor	RM21407026	21407026
D4 (300) D6 (400/435)	Compres. <b>NEW</b>	REC21405493	21405493
D8	Alt <b>NEW</b>	REC22954700	22954700
MD2010A, B, C MD2020A, B, C	Alt	RM973534	973534
MD2030A, B, C	Alt	REC978482	978482
MD2040A, B, C	Alt	RM967114	967114
AQAD30A, 31A, 40A, 40B AQD40A, 41A MD30A, 31A, 40A	BA WP & Alt	REC966978	966978
AQAD32A MD32A	BA WP, Alt & DH PS	REC966387	966387
	Compresor	RM3581460	3581460
KAD32P-A	BA WP & Alt	REC861564	861564
	Alt	REC977542	977542
	Compresor	REC860388	860388
KAD42	BA WP & Alt	REC976483	976483
	Alt	REC977542	977542
AQAD41A	BA WP & Alt	REC966978	966978

Modelo Model Modello		REF	R.O. OEM
MD70	BA WP	DAY17305	958481
	Alt	REC966906	966906
	BA WP	GDY17291	9671587
MD100A	29-1/4" BA WP	GDY15335	966958
	33-1/4" Alt	REC57-36356	966974
MD100B	Alt	REC57-36356	966974
TAMD30A, 31A, 40A, 40B, 41A TMD30A, 31A, 40A, 40B, 40C, 41A	BA WP & Alt	REC966978	966978
TAMD61A	Alt	RM967193 (necesita 2 need 2 Ne servono 2)	967193
TAMD63L-A, P-A		REC866653	866653
TAMD70B, C, D, E, TMD70B,C		RM966953	966953
TAMD71A	Alt	RM967193 (necesita 2 need 2 Ne servono 2)	967193
TAMD74A-A, A-B, C-A, C-B, L-A, L-B, P-A, P-B		REC3827273	3827273
TAMD73P-A, WJ-A TAMD74P-A		REC866653	866653
TAMD102A	Alt	GDY15386	966870

## HÉLICES ALUMINO E INOXIDABLES DE 3 Y 4 PALAS 3 & 4 BLADE ALUMINUM & STAINLESS STEEL PROPELLERS ELICHE ALLUMINIO E INOX DA 3 E 4 PALE

### SOLAS

#### AMITA 3

- Hélices de aluminio de 3 palas con núcleo de goma de gran resistencia.
- 3 blade aluminum propeller with heavy duty rubber hub.
- Eliche in alluminio a 3 pale con mozzi in gomma ad alta resistenza.



#### AMITA 3 PLUS

- Diseño de pala grande para un área más grande.
- High camber blade and large blade area design.
- Con un'area più ampia nelle pale.

### SOLAS

#### TITAN

- Hélices de acero inox de 3 palas.
- Diseño de pala grande para un área más grande.
- Gran capacidad de transporte de carga.
- Excelente economía de combustible.
- 3 blade stainless steel propeller.
- High camber blade and large blade area design.
- Great load carrying capability.
- Excellent fuel economy.
- Eliche a 3 pale in acciaio inossidabile.
- Con un'area più ampia nelle pale.
- Ampia capacità di carico.
- Eccellente economia di carburante.

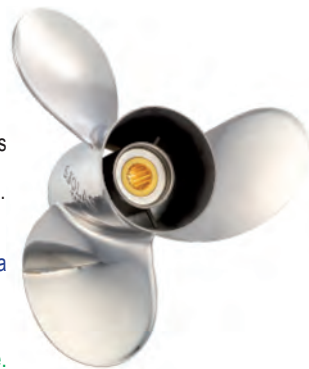

### SOLAS

#### NEW SATURN

- Hélices de acero inoxidable de 3 palas.
- Ofrece buena aceleración y rendimiento.
- Tamaño más pequeño que ofrece un diámetro extragrande.
- Three blade stainless steel propeller.
- Offers good acceleration & all-round performance.
- Smaller pitch sizes offered in extra large diameter with increased blade area.
- Eliche in acciaio inox a 3 pale.
- Consentono buone accelerazioni.
- Con un'area più ampia nelle pale.



### SOLAS

#### HR TITAN 3 PROP

- Hélice de acero inoxidable de 3 palas.
- Alto rendimiento para cascos de alta velocidad.
- La inclinación de la hoja proporciona un excelente elevación de proa y aceleración.
- El diseño de copa grande aumenta la mordida y reduce el deslizamiento.
- Three blade stainless steel propeller.
- Performance prop for high speed planning hulls.
- High rake blade design provides excellent bow lift and acceleration.
- Heavy cup design increases bite and reduces slip.
- Eliche di acciaio inox a 3 pale.
- Alte prestazioni per scafi ad alta velocità.
- Il passo della pala fornisce un'eccellente elevazione e accelerazione.
- Il disegno della coppa aumenta le prestazioni e riduce lo slittamento.



**SISTEMA CÓDIGO DE REFERENCIAS**  
**PART NO. CODING SYSTEM**  
**SISTEMA DI CODICE**

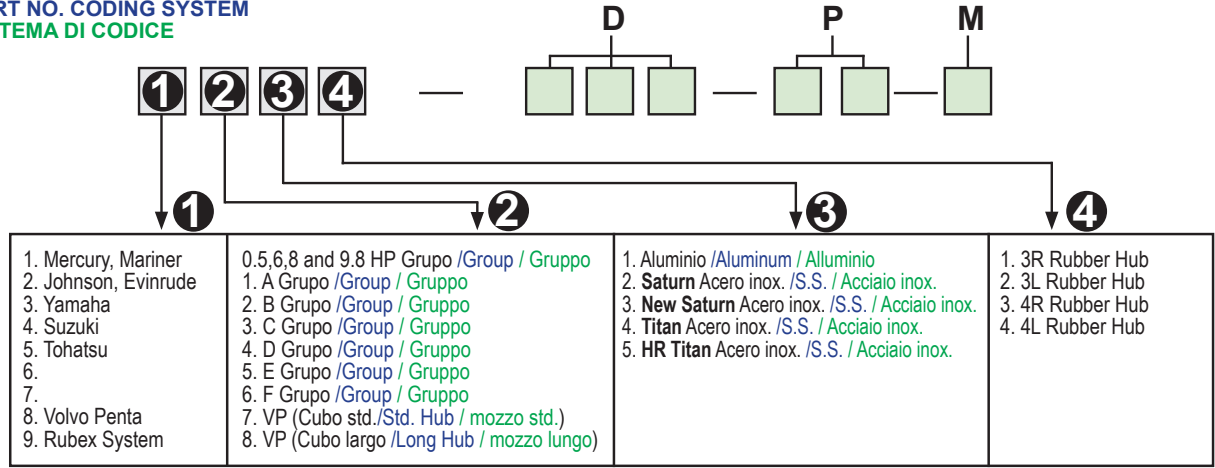

Ejemplo / Note / Esempio

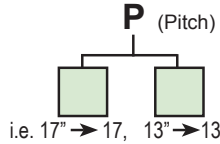
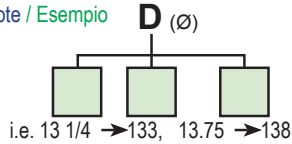

HP	R.O. OEM	B	D	P	R	TIPO TYPE	ALUMINIO ALUMINIUM ALLUMINIO		INOX STAINLESS STEEL		
							AMITA 3	AMITA 3 PLUS	NEW SATURN	TITAN	HR TITAN 3
<b>VOLVO AQUAMATIC</b>											
AQ270	854996	3	15	15	R	Alum.			SOL8831-150-15		
AQ275	854981	3	15	15	L	Alum.			SOL8832-150-15		
AQ280	854997	3	15	17	R	Alum.			SOL8831-150-17		
AQ290	854982	3	15	17	L	Alum.			SOL8832-150-17		
	854998	3	15	18	R	Alum.			SOL8831-150-19		
	854983	3	15	19	L	Alum.			SOL8832-150-19		
	854999	3	15	21	R	Alum.			SOL8831-150-21		
Cubo largo	854984	3	15	21	L	Alum.			SOL8832-150-21		
Long Hub		3	15	21	L	Alum.					
Mozzo lungo											
11.5 mm											
AQ200D/290 AQ225D/290	872001	3	15	15	R	Alum.	SOL8811-150-15	SOL8811-158-15		SOL8841-156-15	
AQ260D/290 AQ290A/290	854987	3	15	15	L	Alum.	SOL8812-150-15	SOL8812-158-15		SOL8842-156-15	
	872002	3	14.8	17	R	Alum.	SOL8811-148-17	SOL8811-155-17		SOL8841-156-17	
AQAD40B/290 AQAD41/290	854988	3	14.8	17	L	Alum.	SOL8812-148-17	SOL8812-155-17		SOL8842-156-17	
	872003	3	14.5	19	R	Alum.	SOL8811-145-19	SOL8811-153-19		SOL8841-156-19	
	854989	3	14.5	19	L	Alum.	SOL8812-145-19	SOL8812-153-19		SOL8842-156-19	
Cubo largo		3	14.5	19	L	Alum.	SOL8811-143-21	SOL8811-153-21		SOL8841-156-21	
Long Hub	872004	3	14.3	21	R	Alum.	SOL8812-143-21	SOL8812-153-21		SOL8842-156-21	
Mozzo lungo	854990	3	14.3	21	L	Alum.	SOL8811-142-23			SOL8841-156-23	
			14.2	23	R	Alum.	SOL8812-142-23			SOL8842-156-23	
			14.2	23	L	Alum.					
Cubo estandar		3	15.5	15	L	Alum.	SOL8712-150-15				
Standard Hub		3	14.8	17	L	Alum.	SOL8712-148-17				
Mozzo standard		3	14.5	19	L	Alum.	SOL8712-145-19				
9,5 mm		3	14.3	21	L	Alum.	SOL8712-143-21				
<b>VOLVO SX</b>											
3.0 L, 4.3 L	3817466	3	15	15	R	ALUM	SOL8611-150-15	SOL8613-148-15			SOL8641-155-15
	3817471	3	15	15	L	ALUM	SOL8612-150-15	SOL8614-148-15			SOL8642-155-15
5.0 L	3817467	3	14.8	17	R	ALUM	SOL8611-148-17	SOL8613-145-17			SOL8651-148-17
5.7 L	3817472	3	14.8	17	L	ALUM	SOL8612-148-17	SOL8614-145-17			SOL8652-148-17
5.8 L	3817468	3	14.5	19	R	ALUM	SOL8611-145-19	SOL8613-143-19			SOL8651-148-19
7.4 L	3817473	3	14.5	19	L	ALUM	SOL8612-145-19	SOL8614-143-19			SOL8652-148-19
	3817469	3	14.3	21	R	ALUM	SOL8611-143-21	SOL8613-140-21			SOL8651-145-21
(19 Estrías / Spline / Denti)		3	14.3	21	L	ALUM	SOL8612-143-21	SOL8614-140-21			SOL8652-145-21
	3817470	3	14.3	21	L	ALUM	SOL8611-142-23				SOL8642-145-23
	3850305	3	14.2	23	R	ALUM					SOL8651-140-24
	3850315	3	15 5/8	15	R	INOX - SS					
	3862462	3	15 5/8	15	L	INOX - SS					
	3860714	3	15 5/8	17	R	INOX - SS					
	3860708	3	15 5/8	17	L	INOX - SS					
	3860715	3	15 5/8	19	R	INOX - SS					
	3860709	3	15 5/8	19	L	INOX - SS					
	3860716	3	15 5/8	21	R	INOX - SS					
	3860710	3	15 5/8	21	L	INOX - SS					
	3860717	3	14 1/4	23	R	INOX - SS					
		3	15 5/8	23	L	INOX - SS					

B= PALAS / Blades / Pale  
D= DIÁMETRO / Diametre / Diametro  
P= PASO / Pich / Passo

R=ROTACIÓN / Rotation / Rotazione  
(R) Derecha / Right / DX  
(L) Izquierda / Left / SX

## HÉLICES ALUMINIO E INOX CON NÚCLEO INTERCAMBIABLE ALUMINIUM & SS PROPELLERS WITH INTERCHANGEABLE HUB ELICHE ALLUMINIO E INOX CON MOZZO INTERCAMBIABILE

Altas prestaciones. Núcleo de goma intercambiable con sistemas Flo-Torq & Vortex System. Disponible en acero inox y aluminio  
High performance / Rubber Hub interchangeable with Flo-Torq & Vortex System. Available in stainless Steel & Aluminium Propeller  
Alte prestazioni. Mozzo in gomma intercambiabile con sistema Flo-Torq & Vortex System. Disponibile in acciaio inox e alluminio.

ALUMINIO ALUMINIUM ALLUMINIO	Ø	PASO PICH PASSO	ROTACIÓN ROTATION ROTAZIONE
<b>3 PALAS / BLADES / PALE</b>			
SOL9511-150-15	15	15	R
SOL9512-150-15	15	15	L
SOL9511-148-17	14,8	17	R
SOL9512-148-17	14,8	17	L
SOL9511-145-19	14,5	19	R
SOL9512-145-19	14,5	19	L
SOL9511-143-21	14,3	21	R
SOL9512-143-21	14,3	21	L
<b>4 PALAS / BLADES / PALE</b>			
SOL9513-148-15	14,75	15	R
SOL9513-145-17	14,5	17	R
SOL9513-143-19	14,25	19	R
SOL9513-140-21	14	21	R

(R) Derecha / Right / DX  
(L) Izquierda / Left / SX



**RUBEX**

ACERO INOX. STAINLESS STEEL ACCIAIO INOX.	Ø	PASO PICH PASSO	ROTACIÓN ROTATION ROTAZIONE
<b>3 PALAS / BLADES / PALE</b>			
SOL9571-158-15	15 <sup>3/4</sup>	15	R
SOL9572-158-15	15 <sup>3/4</sup>	15	L
SOL9571-155-17	15 <sup>1/2</sup>	17	R
SOL9572-155-17	15 <sup>1/2</sup>	17	L
SOL9571-153-19	15 <sup>1/4</sup>	19	R
SOL9572-153-19	15 <sup>1/4</sup>	19	L
SOL9571-150-21	15	21	R
SOL9572-150-21	15	21	L
SOL9571-148-23	14 <sup>3/4</sup>	23	R
SOL9572-148-23	14 <sup>3/4</sup>	23	L
<b>4 PALAS / BLADES / PALE</b>			
SOL9531-145-15	14 <sup>1/2</sup>	15	R
SOL9532-145-15	14 <sup>1/2</sup>	15	L
SOL9531-143-17	14 <sup>1/4</sup>	17	R
SOL9532-143-17	14 <sup>1/4</sup>	17	L
SOL9531-140-19	14	19	R
SOL9532-140-19	14	19	L
SOL9531-140-21	14	21	R
SOL9532-140-21	14	21	L
SOL9531-140-23	14	23	R
SOL9532-140-23	14	23	L

Ref.	R.O. OEM
SOLRBX-105	

SX (1994+) 19 Estrías / spline / denti



## HÉLICES ORIGINALES VOLVO VOLVO ORIGINAL PROPELLERS ELICHE ORIGINALI VOLVO

VOLVO AQUAMATIC, 200, 250, 270, 275, 280 Y 290

HÉLICES DE CUBO LARGO 11,5 cm  
LONG HUB PROPELLERS 11,5 cm  
ELICHE CON MOZZO DA 11,5 cm

REF	R.O. OEM	REF	R.O. OEM	Ø & PASP Ø & PITCH Ø & PASSO
RM854977	854977	RM854992	854992	14 x 17
RM854978	854978	RM854993	854993	14 x 19
RM854979	854979	RM854994	854994	14 x 21
RM854982	854982	RM854997	854997	15 x 17
RM854983	854983	RM854998	854998	15 x 19
RM854984	854984	RM854999	854999	15 x 21
RM854986	854986			16 x 13

HÉLICES DE CUBO ESTANDAR 9,5 cm  
STANDARD HUB PROPELLERS 9,5 cm  
ELICHE CON MOZZO STANDARD DA 9,5 cm

REF	R.O. OEM	REF	R.O. OEM	Ø & PASP Ø & PITCH Ø & PASSO
RM814626	814626	RM814631	814631	14 x 15
RM814627	814627	RM814632	814632	14 x 17
RM814628	814628	RM814633	814633	14 x 19
RM813316	813316	RM813317	813317	15 x 13
RM814611	814611	RM814615	814615	15 x 15
RM814612	814612	RM814616	814616	15 x 17

Para instalar hélices de cubo standard en colas con n° de serie PZ2877179 se necesitan:  
Following parts are needed to install standard hub props in drives with serial # PZ2877179:  
Per installare eliche con il mozzo standard nei piedi con n° di serie PZ2877179 servono:

Para instalar hélices de cubo largo en colas 270 con eje taladrado, 275, 280 y 290 se necesitan:  
Following parts are needed to install long hub props in drilled shaft 270, 275, 280 & 290 drives:  
Per installare eliche con il mozzo lungo 11,5 cm nei piedi 270, 275, 280 e 290 servono:

Unids. Units Unità	Ref.	Descripción	Description	Descrizione
1	REC854045	CONO	CONE	CONO
1	REC850888	ARANDELA	O-RING	RONDELLA
1	REC850889	TORNILLO	SCREW	VITE

Unids. Units Unità	Ref.	Descripción	Description	Descrizione
1	REC854045	CONO	CONE	CONO
1	REC854047	ANILLO ESPACIADOR	THRUST WASHER	SPESSORE
1	REC850888	ARANDELA	O-RING	RONDELLA
1	REC850889	TORNILLO	SCREW	VITE



Las colas con n° de serie anterior a PZ2877179 se necesitan:  
Earlier models to PZ2877179 need:  
Per piedi con n° di serie precedente a PZ2877179 serve:

Unids. Units Unità	Ref.	Descripción	Description	Descrizione
1	REC897367	ARANDELA	O-RING	RONDELLA

# HÉLICES DUOPRO DUOPRO PROPELLERS ELICHE DUOPRO

## HÉLICES DUOPROP ALUMINIO ALUMINIUM DUOPROP PROPELLERS ELICHE DUOPROP IN ALLUMINIO

Esta tabla es orientativa, debe comprobarse con la documentación del motor.  
This table is as orientation. Must be checked with the engine information  
Questa tabella è come orientamento. Deve essere controllato con le informazioni del motore

 KAD42, 43, 44, 300		HÉLICE DELANTERA FRONT PROPELLER ELICHE ANTERIORI 3 PALAS IZQUIERDA 3 BLADES LEFT 3 PALE SX	HÉLICE TRASERA REAR PROPELLER ELICHE POSTERIORE 4 PALAS DERECHA 4 BLADES RIGHT 4 PALE DX
B3			REC4-17ALU
	A3 Altas prestaciones high performance Alte prestazioni		REC4-19ALU
	A3		REC4-19ALU
B4			REC4-19ALU
	A4 Altas prestaciones high performance Alte prestazioni		REC4-19ALU
	A6	REC3-21ALU	
B6		REC3-21ALU	
	A7 Altas prestaciones high performance Alte prestazioni	REC3-21ALU	



### DP280, DP290, DP-A, DP-E

REF	R.O. OEM	ANTIGUO TIPO OLD TYPE TIPO VECCHIO		NUEVO TIPO NEW TYPE TIPO NUOVO
		A	B	J
REC21924262	854814 854765 2194262	2	1	2
REC21924263	854815 854766 21924263	3	2	3
REC21924264	854816 854767 21924264	4	3	4
REC21924265	854817 854768 21924265	5	4	5
REC21924266	854769 854818 21924266	6	5	6
REC21924267	854819 854770 21924267	7	6	7
REC21924268	854820 854771 21924268	8	7	8
REC21924269	854821 854772 21924269	9	8	9
REC21924270	854773 21924270	10		10
BVA0990730A	854766	3		
BVA0990740A	854767	4		
BVA0990750A	854768	5		
BVA0990760A	854769	6		
BVA0990770A	854770	7		
BVB0990630A	854816		3	
BVB0990640A	854817		4	
BVB0990650A	854818		5	
BVB0990660A	854819		6	
BVB0990670A	854820		7	



Nuevo "Type J" sustituye al "Type A" y al "Type B"  
New "Type J" replaces "Type A" and "Type B"  
Il nuovo "Tipo J" sostituisce "Tipo A" e "Tipo B"



Para motores que excedan los 240HP o barcos de +38 knots se recomienda la instalación de hélices inox "Type C"  
For engines exceeding 240HP or +38 knots, the installation of "Type C" stainless steel propellers is recommended  
Per motori superiori a 240 HP o +38 nodi, si consiglia l'installazione di eliche in acciaio inossidabile "Tipo C"

**KITS HÉLICES DUOPROP INOX**  
**DUOPROP STAINLESS STEEL KITS**  
**KIT ELICHE DUOPROP INOX**

DP280, DP290, DP-G

 KAD42, 43, 44, 300	 A2	Todos los motores All engines tutti motori	HÉLICE DELANTERA 3 PALAS IZQUIERDA HELICE TRASERA 4 PALAS DERECHA FRONT PROPELLER 3 BLADES LEFT REAR PROPELLER 4 BLADES RIGHT ELICHE ANTERIORI 3 PALE SX ELICHE POSTERIORE 4 PALE DX
B2	A2		RECC2
		C2	RECC2
B3	A3		RECC3
			RECC3
	A3 Altas prestaciones high performance Alte prestazioni		RECC4
	A4		RECC4
B4			RECC4
		C3	RECC4
	A6		RECC6
	A7		RECC6
B6			RECC6
		C5	RECC6



**KITS HÉLICES DUOPROP ALUMINIO PARA COLAS DPS & XDP**  
**DUOPROP ALLUMINIUM KITS FOR DRIVES DPS & XDP**  
**KIT ELICHE DUOPROP IN ALLUMINIO PER PIEDI DPS & XDP**

KIT DE 2 HÉLICES DE 4 PALAS  
KIT 2 PROPELLERS 4 BLADES  
KIT DI 2 ELICHE A 4 PALE



Modelo Model Modello	REF	R.O. OEM
D2 / I2	RM3851482	3851482 21258482
D3 / I3	RM3851483	3851483 21258483
D4 / I4	RM3851484	21258484
D5 / I5	RM3856365	21258485
D6 / I6	RM3856366	3856366 21258486
D7 / I7	RM3856367	3856367 21258487



La nueva generación de hélices "Type I" sustituye al "Type D"  
The new generation of propellers "Type I" replaces "Type D"  
La nuova generazione di eliche "Tipol" sostituisce "Tipo D"

**KITS HÉLICES DUOPROP NIBRAL PARA COLAS DPH**  
**DUOPROP NIBRAL KITS FOR DRIVES DPH**  
**KIT ELICHE DUOPROP IN NIBRAL PER PIEDI DPH**

**KIT DE 2 HÉLICES DE 3 & 4 PALAS**  
**KIT 2 PROPELLERS 3 & 4 BLADES**  
**KIT DI 2 ELICHE A 3 & 4 PALE**

Diseñado para capturar el tremendo par de los motores **D4** y **D6**, la geometría de la pala patentada proporciona la interacción óptima entre las hélices delanteras y traseras para una eficiencia sobresaliente y un funcionamiento sin problemas. El gran área de la pala y la gran resistencia aseguran el máximo agarre y maniobrabilidad. La aleación nibral (níquel-bronce-aluminio) extremadamente fuerte garantiza un crecimiento mínimo y una excelente durabilidad. Su completo aislamiento de goma y aislamiento galvánico lo hace perfectamente compatible con las hélices **DPH**.

Designed to capture the tremendous torque from the **D4 & D6** engines, the patented blade geometry provides optimal interaction between front and rear propellers for outstanding efficiency and smooth and comfortable operation. The large blade area and great strength ensure maximum grip and maneuverability. The extremely strong nibral (nickel - bronze - aluminium) alloy ensures minimum growth and excellent durability. Complete with shock-absorbing rubber brushing and galvanic isolation makes it perfectly matched for the **DPH** drives.

Progettata per ottimizzare la straordinaria coppia dei motori **D4 e D6**, la geometria della pala brevettata offre un'interazione ottimale tra eliche anteriori e posteriori per un'efficienza eccezionale ed un funzionamento fluido e confortevole. L'ampia area della pala e la grande robustezza garantiscono la massima aderenza e manovrabilità. La lega nibral (nickel - bronzo - alluminio) estremamente robusta garantisce una crescita minima e un'eccellente durata. Completo di gomma ammortizzante e isolamento galvanico lo rende perfettamente abinabile ai **DPH**.

Modelo Model Modello	REF	R.O. OEM
G4	REC22898644	22898644
G5	REC22898645	22898645
G6	REC22898646	22898646
G7	REC22898647	22898647



**KIT LLAVE HÉLICES DP**  
**DP PROP WRENCH KIT**  
**KIT CHIAVE ELICHE DP**

Ref.	R.O. OEM
REC885195	885195



# GUÍA MANTENIMIENTO DIESEL DIESEL MAINTENANCE GUIDE GUIDA DI MANUTENZIONE DIESEL



Modelo Model Modello	DESCRIPCIÓN	DESCRIPTION	DESCRIZIONE	Ref.
MD1A, B MD2A, B MD5A, B, C MD11C, D	FILTRO ACEITE	OIL FILTER	FILTRO OLIO	REC834337
	FILTRO COMBUSTIBLE MD1, 2, 5A, 5B, 11C	FUEL FILTER ELEMENT MD1, 2, 5A, 5B, 11C	FILTRO COMBUSTIBILE MD1, 2, 5A, 5B, 11C	REC876554
	FILTRO COMBUSTIBLE BLINDADO MD5, MD11	FUEL FILTER MD5, MD11	FILTRO COMBUSTIBILE MD5, MD11	REC829913
	IMPULSOR 6 TORNILLOS EN TAPA	IMPELLER 6 BOLT IN CAP	GIRANTE 6 VITI EN COPPERCHIO	JOH09-806B
	IMPULSOR 4 TORNILLOS EN TAPA	IMPELLER 4 BOLT IN CAP	GIRANTE 4 VITI EN COPPERCHIO	JOH09-808B
	TERMOSTATO MD1B 75°	THERMOSTAT MD1B 75°	TERMOSTATO MD1B 75°	REC875580
	TERMOSTATO MD2, MD11 60°	THERMOSTAT MD2, MD11 60°	TERMOSTATO MD2, MD11 60°	REC876080
	TERMOSTATO AGUA DULCE MD11 CON CIRCUITO CERRADO 74°	THERMOSTAT FRESH WATER MD11 74°	TERMOSTATO ACQUA DOLCE MD11 CON CIRCUITO CHIUSO 74°	REC877349
	TERMOSTATO MD5A, B, C 60°	THERMOSTAT MD5A, B, C 60°	TERMOSTATO MD5A, B, C 60°	REC875783
	CORREA DINAMO MD1, MD2	BELT DYNAMO MD1, MD2	CINGHIA DINAMO MD1, MD2	REC966990
	CORREA ALTERNADOR MD1, MD2 900 mm	BELT ALTERNATOR MD1, MD2 900 mm	CINGHIA ALTERNATORE MD1, MD2 900 mm	REC966906
	CORREA ALTERNADOR MD1, MD2 1.025 mm	BELT ALTERNATOR MD1, MD2 1.025 mm	CINGHIA ALTERNATORE MD1, MD2 1.025 mm	REC3852106
	CORREA MD5A, B, C	BELT MD5A, B, C	CINGHIA MD5A, B, C	REC966990
	CORREA MD11C, D 900 mm	BELT MD11C, D 900 mm	CINGHIA MD11C, D900 mm	REC966906
	CORREA MD11C, D 1.400 mm	BELT MD11C, D 1.400 mm	CINGHIA MD11C, D 1.400 mm	REC966931
CORREA MD11C, D 1.550 mm CON CIRCUITO CERRADO	BELT MD11C, D 1.550 mm FRESH WATER	CINGHIA MD11C, D 1.550 mm CON CIRCUITO CHIUSO	REC966942	
MD6A, B	FILTRO ACEITE	OIL FILTER	FILTRO OLIO	REC834337
	FILTRO COMBUSTIBLE	FUEL FILTER	FILTRO COMBUSTIBILE	REC21492771
	IMPULSOR 6 TORNILLOS EN TAPA	IMPELLER 6 BOLT IN CAP	GIRANTE 6 VITI EN COPPERCHIO	JOH09-806B
	IMPULSOR 4 TORNILLOS EN TAPA	IMPELLER 4 BOLT IN CAP	GIRANTE 4 VITI EN COPPERCHIO	JOH09-808B
	TERMOSTATO 60°	THERMOSTAT 60°	TERMOSTATO 60°	REC875796
CORREA DINAMO MD6A, B (1234+)	BELT DYNAMO MD6A, B (1234+)	CINGHIA DINAMO MD6A, B (1234+)	REC3858462	
CORREA ALTERNADOR	BELT ALTERNATOR	CINGHIA ALTERNATORE	REC966933	
MD7A, B	FILTRO ACEITE	OIL FILTER	FILTRO OLIO	REC834337
	FILTRO COMBUSTIBLE	FUEL FILTER	FILTRO COMBUSTIBILE	REC21492771
	IMPULSOR	IMPELLER	GIRANTE	JOH09-808B
	TERMOSTATO 60°	THERMOSTAT 60°	TERMOSTATO 60°	REC875796
	CORREA MD7A	BELT MD7A	CINGHIA MD7A	REC966933
CORREA MD7B	BELT MD7B	CINGHIA MD7B	REC966707	
MD3B MD17C, D	FILTRO ACEITE	OIL FILTER	FILTRO OLIO	REC834337
	FILTRO COMBUSTIBLE	FUEL FILTER	FILTRO COMBUSTIBILE	REC876554
	FILTRO COMBUSTIBLE BLINDADO MD17	FUEL FILTER MD17	FILTRO COMBUSTIBILE MD17	REC829913
	IMPULSOR	IMPELLER	GIRANTE	JOH09-808B
	TERMOSTATO 60°	THERMOSTAT 60°	TERMOSTATO 60°	REC876080
	TERMOSTATO AGUA DULCE CON CIRCUITO CERRADO 74°	THERMOSTAT FRESH WATER 74°	TERMOSTATO ACQUA DOLCE 74° CIRCUITO CHIUSO	REC966383
CORREA MD17C, D	BELT MD17C, D	CINGHIA MD17C, D	REC966383	
CORREA MD17C, D 1.375 mm	BELT MD17C, D 1.375 mm	CINGHIA MD17C, D 1.375 mm	REC966383	
CIRCUITO CERRADO	FRESH WATER	CIRCUITO CHIUSO	GDY15545	
MD21A, B AQD21A, B	FILTRO ACEITE	OIL FILTER	FILTRO OLIO	REC3581621
	FILTRO COMBUSTIBLE	FUEL FILTER	FILTRO COMBUSTIBILE	REC3581078
	IMPULSOR	IMPELLER	GIRANTE	JOH09-801B
	TERMOSTATO	THERMOSTAT	TERMOSTATO	REC875785
	CORREA	BELT	CINGHIA	REC829207
MD22A, B TMD22A, B TAMD22A	FILTRO ACEITE (A)	OIL FILTER (A)	FILTRO OLIO (A)	REC861476
	FILTRO ACEITE (B, C)	OIL FILTER (B, C)	FILTRO OLIO (B, C)	REC3517857
	FILTRO COMBUSTIBLE	FUEL FILTER	FILTRO COMBUSTIBILE	REC3840335
	IMPULSOR	IMPELLER	GIRANTE	JOH09-1027B
	TERMOSTATO	THERMOSTAT	TERMOSTATO	RM6210419
CORREA	BELT	CINGHIA	RM966912	
MD30A, B, D AQ30A, B, D TAMD30A, B, D TMD30A, B, D	FILTRO ACEITE	OIL FILTER	FILTRO OLIO	REC3517857
	FILTRO COMBUSTIBLE	FUEL FILTER	FILTRO COMBUSTIBILE	REC21492771
	FILTRO AIRE	AIR FILTER	FILTRO ARIA	REC876185
	FILTRO CÁRTER	CÁRTER FILTER	FILTRO CÁRTER	REC876069
	ÁNODO MOTOR	ENGINE ANODE	ANODO MOTORE	CM838929
	IMPULSOR	IMPELLER	GIRANTE	JOH09-1028B
	TERMOSTATO	THERMOSTAT	TERMOSTATO	REC3831425
	CORREA 1.100 mm	BELT 1.100 mm	CINGHIA 1.100 mm	REC966978
AQAD31, A AD31A, B, D, XD, P, L-A MD31, A TMD31A, B, D, L-A TAMD31A, B, D, P, L, M, S-A KAD32A	FILTRO ACEITE	OIL FILTER	FILTRO OLIO	REC3517857
	FILTRO COMBUSTIBLE	FUEL FILTER	FILTRO COMBUSTIBILE	REC21492771
	FILTRO AIRE antiguo	AIR FILTER old	FILTRO ARIA vecchio	REC858488
	FILTRO AIRE moderno	AIR FILTER new	FILTRO ARIA moderno	REC21646645
	FILTRO CÁRTER	CÁRTER FILTER	FILTRO CÁRTER	REC876069
	ÁNODO MOTOR	ENGINE ANODE	ANODO MOTORE	CM838929
	IMPULSOR	IMPELLER	GIRANTE	JOH09-1028B
	TERMOSTATO antiguo 70°	THERMOSTAT old 70°	TERMOSTATO vecchio 70°	REC3831426
	TERMOSTATO moderno 81°	THERMOSTAT new 81°	TERMOSTATO moderno 81°	REC3831424
	CORREA COMPRESOR KAD32-PA	COMPRESOR BELT KAD32-PA	CINGHIA COMPRESSORE KAD32-PA	RM3581460
	CORREA BOMBA KAD32-PA	BELTPUMP KAD32-PA	CINGHIA PUMP KAD32-PA	REC861564
	CORREA ALTERNADOR KAD32-PA	BELT ALTERNATOR KAD32-PA	CINGHIA ALTERNATORE KAD32-PA	REC977542
CORREA 1.100 mm	BELT 1.100 mm	CINGHIA 1.100 mm	REC966978	



Modelo Model Modello	DESCRIPCIÓN	DESCRIPTION	DESCRIZIONE	Ref.
MD40A TMD40A, B, C TAMD40A B AQD40A AQAD40A, B	FILTRO ACEITE	OIL FILTER	FILTRO OLIO	REC471034
	FILTRO COMBUSTIBLE	FUEL FILTER	FILTRO COMBUSTIBILE	REC3840335
	FILTRO AIRE	AIR FILTER	FILTRO ARIA	REC876185
	FILTRO CÁRTER	CÁRTER FILTER	FILTRO CÁRTER	REC876069
	ÁNODO MOTOR	ENGINE ANODE	ANODO MOTORE	CM838929
	IMPULSOR	IMPELLER	GIRANTE	JOH09-1028B
	IMPULSOR TAMD40, AD40	IMPELLER TAMD40, AD40	GIRANTE TAMD40, AD40	JOH09-1029B
	TERMOSTATO antiguo 70°	THERMOSTAT old 70°	TERMOSTATO vecchio 70°	REC3831426
	TERMOSTATO moderno 81°	THERMOSTAT new 81°	TERMOSTATO moderno 81°	REC3831424
CORREA 1.100 mm	BELT 1.100 mm	CINGHIA 1.100 mm	REC966978	
TMD41A, B, D, L-A TAMD41A, B, D D41A, B, D, L-A AD41A, B, D AQD41A AQAD41A	FILTRO ACEITE	OIL FILTER	FILTRO OLIO	REC471034
	FILTRO COMBUSTIBLE	FUEL FILTER	FILTRO COMBUSTIBILE	REC3840335
	FILTRO AIRE antiguo Ø 200 mm	AIR FILTER old Ø 200mm	FILTRO ARIA vecchio Ø 200 mm	REC858488
	FILTRO AIRE moderno Ø 165 mm	AIR FILTER new Ø 165 mm	FILTRO ARIA moderno Ø 165 mm	REC21646645
	FILTRO CÁRTER	CÁRTER FILTER	FILTRO CÁRTER	REC876069
	ÁNODO MOTOR	ENGINE ANODE	ANODO MOTORE	CM838929
	IMPULSOR	IMPELLER	GIRANTE	JOH09-1028B
	TERMOSTATO antiguo 70°	THERMOSTAT old 70°	TERMOSTATO vecchio 70°	REC3831426
	TERMOSTATO moderno 81°	THERMOSTAT new 81°	TERMOSTATO moderno 81°	REC3831424
CORREA 1.100 mm	BELT 1.100 mm	CINGHIA 1.100 mm	REC966978	
TAMD41P, L, M, H-A, H-B AD41P, L-A KAD42A, B, P-A KAMD42A, B, P-A KAD43P-A KAMD43P-A	FILTRO ACEITE (41)	OIL FILTER (41)	FILTRO OLIO (41)	REC471034
	FILTRO ACEITE (42, 43)	OIL FILTER (42, 43)	FILTRO OLIO (42, 43)	REC127695-35150
	FILTRO COMBUSTIBLE	FUEL FILTER	FILTRO COMBUSTIBILE	REC3840335
	FILTRO AIRE antiguo (41) Ø 200 mm	AIR FILTER old (41) Ø 200 mm	FILTRO ARIA vecchio (41) Ø 200 mm	REC858488
	FILTRO AIRE moderno (41), KAD42WK Ø 165 mm	AIR FILTER new (41), KAD42WK Ø 165 mm	FILTRO ARIA moderno (41), KAD42WK Ø 165 mm	REC21646645
	FILTRO AIRE (42, 43)	AIR FILTER (42, 43)	FILTRO ARIA (42, 43)	REC876185
	FILTRO CÁRTER	CÁRTER FILTER	FILTRO CÁRTER	REC876069
	ÁNODO MOTOR	ENGINE ANODE	ANODO MOTORE	CM838929
	IMPULSOR	IMPELLER	GIRANTE	JOH09-1028B
	TERMOSTATO moderno 81°	THERMOSTAT new 81°	TERMOSTATO moderno 81°	REC3831424
	CORREA COMP KAD42A, B, KAMD42A, B, P-A	BELT COMP. KAD42A, B, KAMD42A, B, P-A	CINGHIA COMP. KAD42A, B, KAMD42A, B, P-A	REC860388
	CORREA COMP. KAD43P-A, KAMD43P-A	BELT COMP. KAD43P-A, KAMD43P-A	CINGHIA COMP. KAD43P-A, KAMD43P-A	REC860388
	CORREA BOMBA KAD42A, B, KAMD42A, B	BELT PUMP KAD42A, B, KAMD42A, B	CINGHIA PUMP KAD42A, B, KAMD42A, B	REC976483
CORREA ALT. KAD42, KAMD42, KAD43, KAMD43	BELT ALT. KAD42, KAMD42, KAD43, KAMD43	CINGHIA ALT. KAD42, KAMD42, KAD43, KAMD43	REC977542	
KAD44P-A, P, B, P-C KAMD44P-A, P-B, P-C KAD300A KAMD300A	FILTRO ACEITE	OIL FILTER	FILTRO OLIO	REC127695-35150
	FILTRO COMBUSTIBLE	FUEL FILTER	FILTRO COMBUSTIBILE	REC3840335
	FILTRO AIRE	AIR FILTER	FILTRO ARIA	REC876185
	FILTRO CÁRTER	CÁRTER FILTER	FILTRO CÁRTER	REC876069
	IMPULSOR	IMPELLER	GIRANTE	JOH09-1028B
	TERMOSTATO moderno 81°	THERMOSTAT new 81°	TERMOSTATO moderno 81°	REC3831424
	CORREA COMP KAD44P-B, C, KAM- D44P-A, B, C	BELT COMP. KAD44P-B, C, KAMD44P-A, B, C	CINGHIA COMP. KAD44P-B, C, KAMD44P-A, B, C	REC860388
	CORREA COMP. KAD300-A, KAMD300-A	BELT COMP. KAD300-A, KAMD300-A	CINGHIA COMP. KAD300-A, KAMD300-A	REC860388
	CORREA BOMBA KAD44P-B, C, KAMD44P-A, B, C	BELT PUMP KAD44P-B, C, KAMD44P-A, B, C	CINGHIA PUMP KAD44P-B, C, KAMD44P-A, B, C	REC861564
	CORREA ALT. KAD300-A, KAMD300-A	BELT ALT. KAD300-A, KAMD300-A	CINGHIA ALT. KAD300-A, KAMD300-A	REC977542
TAMD60A, B, C	FILTRO ACEITE	OIL FILTER	FILTRO OLIO	REC127695-35150
	FILTRO COMBUSTIBLE	FUEL FILTER	FILTRO COMBUSTIBILE	REC21492771
	FILTRO AIRE	AIR FILTER	FILTRO ARIA	REC842280
	FILTRO CÁRTER	CÁRTER FILTER	FILTRO CÁRTER	REC876069
	IMPULSOR	IMPELLER	GIRANTE	JOH09-1028B
	TERMOSTATO 70°	THERMOSTAT 70°	TERMOSTATO 70°	REC3831426
	TERMOSTATO 76°	THERMOSTAT 76°	TERMOSTATO 76°	REC3831425
	CORREA ALTERNADOR	BELT ALTERNATOR	CINGHIA ALTERNATORE	REC966906
CORREA BOMBA	BELT PUMP	CINGHIA POMPA	RM966391	
TAMD61A TAMD62A	FILTRO ACEITE	OIL FILTER	FILTRO OLIO	REC847741
	FILTRO ACEITE BY-PASS	OIL FILTER BY-PASS	FILTRO OLIO BY-PASS	REC3827069
	FILTRO COMBUSTIBLE	FUEL FILTER	FILTRO COMBUSTIBILE	REC21492771
	FILTRO AIRE	AIR FILTER	FILTRO ARIA	REC876185
	FILTRO CÁRTER	CÁRTER FILTER	FILTRO CÁRTER	REC876069
	IMPULSOR	IMPELLER	GIRANTE	JOH09-819B
	TERMOSTATO 75°	THERMOSTAT 75°	TERMOSTATO 75°	REC3839110
	CORREA ALTERNADOR TAMD61A, B, TAMD62A	BELT ALTERNATOR TAMD61A, B, TAMD62A	CINGHIA ALTERNATORE TAMD61A, B, TAMD62A	RM967193
TAMD63P-A-L	FILTRO ACEITE	OIL FILTER	FILTRO OLIO	REC847741
	FILTRO ACEITE BY-PASS	OIL FILTER BY-PASS	FILTRO OLIO BY-PASS	REC3827069
	FILTRO COMBUSTIBLE	FUEL FILTER	FILTRO COMBUSTIBILE	REC21492771
	FILTRO AIRE	AIR FILTER	FILTRO ARIA	REC3825038
	FILTRO CÁRTER	CÁRTER FILTER	FILTRO CÁRTER	REC876069
	IMPULSOR	IMPELLER	GIRANTE	JOH09-821B
TERMOSTATO 75°	THERMOSTAT 75°	TERMOSTATO 75°	REC3839110	
CORREA	BELT	CINGHIA	REC866653	
MD70B TMD70B	FILTRO ACEITE	OIL FILTER	FILTRO OLIO	REC127695-35150
	FILTRO COMBUSTIBLE	FUEL FILTER	FILTRO COMBUSTIBILE	REC21492771
	FILTRO AIRE	AIR FILTER	FILTRO ARIA	REC842280
	FILTRO CÁRTER	CÁRTER FILTER	FILTRO CÁRTER	REC876069
	IMPULSOR	IMPELLER	GIRANTE	JOH09-1028B
	TERMOSTATO 70°	THERMOSTAT 70°	TERMOSTATO 70°	REC875785
TERMOSTATO 76°	THERMOSTAT 76°	TERMOSTATO 76°	REC3831425	

Modelo Model Modello	DESCRIPCIÓN	DESCRIPTION	DESCRIZIONE	Ref.
MD70C TMD70C	FILTRO ACEITE	OIL FILTER	FILTRO OLIO	REC127695-35150
	FILTRO COMBUSTIBLE	FUEL FILTER	FILTRO COMBUSTIBILE	REC21492771
	FILTRO AIRE	AIR FILTER	FILTRO ARIA	REC842280
	FILTRO CÁRTER	CÁRTER FILTER	FILTRO CÁRTER	REC876069
	IMPULSOR	IMPELLER	GIRANTE	JOH09-1028B
	TERMOSTATO 70°	THERMOSTAT 70°	TERMOSTATO 70°	REC875785
	TERMOSTATO 76°	THERMOSTAT 76°	TERMOSTATO 76°	REC3831425
	CORREA	BELT	CINGHIA	REC866653
TAMD70B, C	FILTRO ACEITE	OIL FILTER	FILTRO OLIO	REC471034
	FILTRO COMBUSTIBLE	FUEL FILTER	FILTRO COMBUSTIBILE	REC21492771
	FILTRO AIRE	AIR FILTER	FILTRO ARIA	REC842280
	FILTRO CÁRTER	CÁRTER FILTER	FILTRO CÁRTER	REC876069
	IMPULSOR	IMPELLER	GIRANTE	JOH09-1028B
	TERMOSTATO 70°	THERMOSTAT 70°	TERMOSTATO 70°	REC875785
	TERMOSTATO 76°	THERMOSTAT 76°	TERMOSTATO 76°	REC3831425
	CORREA	BELT	CINGHIA	RM966953
TAMD70D, E AQAD70B	FILTRO ACEITE	OIL FILTER	FILTRO OLIO	REC471034
	FILTRO COMBUSTIBLE	FUEL FILTER	FILTRO COMBUSTIBILE	REC21492771
	FILTRO AIRE	AIR FILTER	FILTRO ARIA	REC842280
	FILTRO CÁRTER	CÁRTER FILTER	FILTRO CÁRTER	REC876069
	IMPULSOR	IMPELLER	GIRANTE	JOH09-1028B
	TERMOSTATO 70°	THERMOSTAT 70°	TERMOSTATO 70°	REC875785
	TERMOSTATO 76°	THERMOSTAT 76°	TERMOSTATO 76°	REC3831425
	CORREA	BELT	CINGHIA	RM966953
AQD70C, D	FILTRO ACEITE	OIL FILTER	FILTRO OLIO	REC127695-35150
	FILTRO COMBUSTIBLE	FUEL FILTER	FILTRO COMBUSTIBILE	REC21492771
	FILTRO AIRE	AIR FILTER	FILTRO ARIA	REC842280
	FILTRO CÁRTER	CÁRTER FILTER	FILTRO CÁRTER	REC876069
	IMPULSOR	IMPELLER	GIRANTE	JOH09-1028B
	TERMOSTATO 70°	THERMOSTAT 70°	TERMOSTATO 70°	REC875785
	TERMOSTATO 76°	THERMOSTAT 76°	TERMOSTATO 76°	REC3831425
	CORREA	BELT	CINGHIA	RM966953
TAMD71A, B TAMD72A, P-A	FILTRO ACEITE	OIL FILTER	FILTRO OLIO	REC847741
	FILTRO ACEITE BY-PASS	OIL FILTER BY-PASS	FILTRO OLIO BY-PASS	REC3827069
	FILTRO COMBUSTIBLE	FUEL FILTER	FILTRO COMBUSTIBILE	REC21492771
	FILTRO AIRE	AIR FILTER	FILTRO ARIA	REC876185
	FILTRO CÁRTER	CÁRTER FILTER	FILTRO CÁRTER	REC876069
	IMPULSOR	IMPELLER	GIRANTE	JOH09-819B
	TERMOSTATO	THERMOSTAT	TERMOSTATO	REC3839110
	CORREA	BELT	CINGHIA	RM967193
TAMD73A, P-A, W, TAMD74P-	FILTRO ACEITE	OIL FILTER	FILTRO OLIO	REC847741
	FILTRO ACEITE BY-PASS	OIL FILTER BY-PASS	FILTRO OLIO BY-PASS	REC3827069
	FILTRO COMBUSTIBLE	FUEL FILTER	FILTRO COMBUSTIBILE	REC21492771
	FILTRO AIRE	AIR FILTER	FILTRO ARIA	RM3838952
	FILTRO CÁRTER	CÁRTER FILTER	FILTRO CÁRTER	REC876069
	IMPULSOR	IMPELLER	GIRANTE	JOH09-819B
	TERMOSTATO 70°	THERMOSTAT 70°	TERMOSTATO 70°	REC875785
TERMOSTATO 76°	THERMOSTAT 76°	TERMOSTATO 76°	REC3831425	
	CORREA	BELT	CINGHIA	REC866653
MD100A, B TMD100A	FILTRO ACEITE	OIL FILTER	FILTRO OLIO	REC127695-35150
	FILTRO COMBUSTIBLE	FUEL FILTER	FILTRO COMBUSTIBILE	REC21492771
	FILTRO AIRE	AIR FILTER	FILTRO ARIA	REC842280
	FILTRO CÁRTER	CÁRTER FILTER	FILTRO CÁRTER	REC876069
	IMPULSOR	IMPELLER	GIRANTE	JOH09-819B
	TERMOSTATO 70°	THERMOSTAT 70°	TERMOSTATO 70°	REC875785
	TERMOSTATO 76°	THERMOSTAT 76°	TERMOSTATO 76°	REC3831425
	CORREA ALTERNADOR	BELT ALTERNATOR	CINGHIA ALTERNATORE	REC57-36356
	CORREA BOMBA	BELT PUMP	CINGHIA POMPA	GDY15335
TMD100C TMD102A	FILTRO ACEITE	OIL FILTER	FILTRO OLIO	REC21707134
	FILTRO COMBUSTIBLE	FUEL FILTER	FILTRO COMBUSTIBILE	REC21492771
	FILTRO AIRE	AIR FILTER	FILTRO ARIA	REC842280
	FILTRO CÁRTER	CÁRTER FILTER	FILTRO CÁRTER	REC876069
	IMPULSOR	IMPELLER	GIRANTE	JOH09-819B
	TERMOSTATO 70°	THERMOSTAT 70°	TERMOSTATO 70°	REC875785
	TERMOSTATO 76°	THERMOSTAT 76°	TERMOSTATO 76°	REC3831425
	CORREA BOMBA	BELT PUMP	CINGHIA POMPA	GDY15335
TAMD102A-D TAMD103A	FILTRO ACEITE	OIL FILTER	FILTRO OLIO	REC21707134
	FILTRO COMBUSTIBLE	FUEL FILTER	FILTRO COMBUSTIBILE	REC21492771
	FILTRO CÁRTER	CÁRTER FILTER	FILTRO CÁRTER	REC876069
	IMPULSOR	IMPELLER	GIRANTE	JOH09-819B
	TERMOSTATO 70°	THERMOSTAT 70°	TERMOSTATO 70°	REC875785
	TERMOSTATO 76°	THERMOSTAT 76°	TERMOSTATO 76°	REC3831425
		CORREA ALTERNADOR	BELT ALTERNATOR	CINGHIA ALTERNATORE
MD120A TMD120A TAMD120A	FILTRO ACEITE	OIL FILTER	FILTRO OLIO	REC127695-35150
	FILTRO COMBUSTIBLE	FUEL FILTER	FILTRO COMBUSTIBILE	REC21492771
	FILTRO AIRE	AIR FILTER	FILTRO ARIA	REC842280
	FILTRO CÁRTER	CÁRTER FILTER	FILTRO CÁRTER	REC876069
	IMPULSOR	IMPELLER	GIRANTE	JOH09-819B
	TERMOSTATO 70°	THERMOSTAT 70°	TERMOSTATO 70°	REC875785
	TERMOSTATO 76°	THERMOSTAT 76°	TERMOSTATO 76°	REC3831425
	CORREA ALTERNADOR	BELT ALTERNATOR	CINGHIA ALTERNATORE	GDY15386

Modelo Model Modello	DESCRIPCIÓN	DESCRIPTION	DESCRIZIONE	Ref.	
TMD120B	FILTRO ACEITE	OIL FILTER	FILTRO OLIO	REC21707134	
	FILTRO COMBUSTIBLE	FUEL FILTER	FILTRO COMBUSTIBILE	REC21492771	
	FILTRO AIRE	AIR FILTER	FILTRO ARIA	REC842280	
	FILTRO CÁRTER	CÁRTER FILTER	FILTRO CÁRTER	REC876069	
	TERMOSTATO 70°	THERMOSTAT 70°	TERMOSTATO 70°	REC875785	
	TERMOSTATO 76°	THERMOSTAT 76°	TERMOSTATO 76°	REC3831425	
	CORREA ALTERNADOR	BELT ALTERNATOR	CINGHIA ALTERNATORE	GDY15386	
TAMD120B	FILTRO ACEITE	OIL FILTER	FILTRO OLIO	REC21707134	
	FILTRO COMBUSTIBLE	FUEL FILTER	FILTRO COMBUSTIBILE	REC21492771	
	FILTRO AIRE	AIR FILTER	FILTRO ARIA	REC842280	
	FILTRO CÁRTER	CÁRTER FILTER	FILTRO CÁRTER	REC876069	
	IMPULSOR	IMPELLER	GIRANTE	JOH09-819B	
	TERMOSTATO 70°	THERMOSTAT 70°	TERMOSTATO 70°	REC875785	
	TERMOSTATO 76°	THERMOSTAT 76°	TERMOSTATO 76°	REC3831425	
CORREA ALTERNADOR	BELT ALTERNATOR	CINGHIA ALTERNATORE	GDY15386		
TMD121C	FILTRO ACEITE	OIL FILTER	FILTRO OLIO	REC21707134	
	FILTRO COMBUSTIBLE	FUEL FILTER	FILTRO COMBUSTIBILE	REC21492771	
	FILTRO AIRE	AIR FILTER	FILTRO ARIA	REC842280	
	FILTRO CÁRTER	CÁRTER FILTER	FILTRO CÁRTER	REC876069	
	IMPULSOR	IMPELLER	GIRANTE	JOH09-819B	
	TERMOSTATO 70°	THERMOSTAT 70°	TERMOSTATO 70°	REC875785	
	TERMOSTATO 76°	THERMOSTAT 76°	TERMOSTATO 76°	REC3831425	
CORREA ALTERNADOR	BELT ALTERNATOR	CINGHIA ALTERNATORE	GDY15386		
TAMD121C-D TMD122A TAMD122A-F TAMD122C	FILTRO ACEITE	OIL FILTER	FILTRO OLIO	REC21707134	
	FILTRO COMBUSTIBLE	FUEL FILTER	FILTRO COMBUSTIBILE	REC21492771	
	FILTRO AIRE	AIR FILTER	FILTRO ARIA	REC842280	
	FILTRO CÁRTER	CÁRTER FILTER	FILTRO CÁRTER	REC876069	
	TERMOSTATO 70°	THERMOSTAT 70°	TERMOSTATO 70°	REC875785	
	TERMOSTATO 76°	THERMOSTAT 76°	TERMOSTATO 76°	REC3831425	
	CORREA ALTERNADOR	BELT ALTERNATOR	CINGHIA ALTERNATORE	GDY15386	
TAMD122P-A, D	FILTRO ACEITE	OIL FILTER	FILTRO OLIO	REC847741	
	FILTRO COMBUSTIBLE	FUEL FILTER	FILTRO COMBUSTIBILE	REC21492771	
	FILTRO AIRE	AIR FILTER	FILTRO ARIA	REC842280	
	FILTRO CÁRTER	CÁRTER FILTER	FILTRO CÁRTER	REC876069	
	CORREA ALTERNADOR	BELT ALTERNATOR	CINGHIA ALTERNATORE	GDY15386	
2001, 2022, 2003, 2003T	FILTRO ACEITE	OIL FILTER	FILTRO OLIO	REC834337	
	FILTRO COMBUSTIBLE	FUEL FILTER	FILTRO COMBUSTIBILE	REC829913	
	ÁNODO MOTOR	ENGINE ANODE	ANODO MOTORE	CM838929	
	IMPULSOR (2001, 2002, 2003)	IMPELLER (2001, 2002, 2003)	GIRANTE (2001, 2002, 2003)	JOH09-808B	
	IMPULSOR (2003T)	IMPELLER (2003T)	GIRANTE (2003T)	JOH09-1027B	
	TERMOSTATO 62°	THERMOSTAT 70°	TERMOSTATO 70°	REC877355	
	TERMOSTATO 74° con circuito cerrado	THERMOSTAT 74° fresh water	TERMOSTATO 74° con circuito chiuso	RM875795	
	CORREA (2001)	BELT (2001)	CINGHIA (2001)	REC966903	
CORREA (2002, 2003)	BELT (2002, 2003)	CINGHIA (2002, 2003)	REC966900		
CORREA (2003T)	BELT (2003T)	CINGHIA (2003T)	REC966906		
MD2010 MD2020 MD2030 MD2040	FILTRO ACEITE (2010, 2020)	OIL FILTER (2010, 2020)	FILTRO OLIO (2010, 2020)	REC861473	
	FILTRO ACEITE (2030, 2040)	OIL FILTER (2030, 2040)	FILTRO OLIO (2030, 2040)	RM3840525	
	FILTRO COMBUSTIBLE	FUEL FILTER	FILTRO COMBUSTIBILE	REC861477	
	FILTRO AIRE (2020, 2030, 2040)	AIR FILTER (2020, 2030, 2040)	FILTRO ARIA (2020, 2030, 2040)	REC3580509	
	IMPULSOR MD2010 (-5101203008), MD2020 (-5101309052)	IMPELLER MD2010 (-5101203008), MD2020 (-5101309052)	GIRANTE MD2010 (-5101203008), MD2020 (-5101309052)	JOH09-806B	
	IMPULSOR MD2010 (5101203009+)	IMPELLER MD2010 (5101203009+)	GIRANTE MD2010 (5101203009+)	JOH09-1026B	
	IMPULSOR MD2020 (5101309053+), MD2030,2040	IMPELLER MD2020 (5101309053+), MD2030,2040	GIRANTE MD2020 (5101309053+), MD2030, 2040	JOH09-1026B	
	TERMOSTATO (2010, 2020)	THERMOSTAT (2010, 2020)	TERMOSTATO (2010, 2020)	RM861911	
	TERMOSTATO (2030, 2040)	THERMOSTAT (2030, 2040)	TERMOSTATO (2030, 2040)	RM3580365	
	CORREA MD2010A, B, C, MD2020A, B, C	BELT MD2010A, B, C, MD2020A, B, C	CINGHIA MD2010A, B, C, MD2020A, B, C	RM973534	
	CORREA MD2030A, B, C	BELT MD2030A, B, C	CINGHIA MD2030A, B, C	REC978482	
	CORREA MD2040A, B, C	BELT MD2040A, B, C	CINGHIA MD2040A, B, C	RM967114	
	D1-13 D1-20	FILTRO ACEITE	OIL FILTER	FILTRO OLIO	REC861473
		FILTRO COMBUSTIBLE	FUEL FILTER	FILTRO COMBUSTIBILE	REC861477
IMPULSOR		IMPELLER	GIRANTE	JOH09-1026B	
TERMOSTATO		THERMOSTAT	TERMOSTATO	RM3842015	
CORREA		BELT	CINGHIA	RM3809625	
D1-30 D2-40	FILTRO ACEITE	OIL FILTER	FILTRO OLIO	REC3840525	
	FILTRO COMBUSTIBLE	FUEL FILTER	FILTRO COMBUSTIBILE	REC861477	
	IMPULSOR	IMPELLER	GIRANTE	JOH09-1026B	
	TERMOSTATO	THERMOSTAT	TERMOSTATO	RM3842015	
	CORREA D1-30	BELT D1-30	CINGHIA D1-30	RM3812159	
CORREA D2-40	BELT D2-40	CINGHIA D2-40	RM21314684		
D2-50 D2-55 D2-60 D2-75	FILTRO ACEITE	OIL FILTER	FILTRO OLIO	REC3840525	
	FILTRO COMBUSTIBLE	FUEL FILTER	FILTRO COMBUSTIBILE	REC861477	
	FILTRO AIRE	AIR FILTER	FILTRO ARIA	REC3580509	
	IMPULSOR	IMPELLER	GIRANTE	JOH09-1027B	
	TERMOSTATO	THERMOSTAT	TERMOSTATO	RM888624	
	CORREA D2-55	BELT D2-55	CINGHIA D2-55	RM967114	
CORREA D2-75	BELT D2-75	CINGHIA D2-75	REC3584086		
D3, (-MY2009)	FILTRO ACEITE	OIL FILTER	FILTRO OLIO	REC8692305	
	FILTRO COMBUSTIBLE	FUEL FILTER	FILTRO COMBUSTIBILE	RM31261191	
	FILTRO AIRE Redondo	AIR FILTER Round	FILTRO ARIA Rotondo	REC21646645	
	FILTRO AIRE Cuadrado	AIR FILTER Square	FILTRO ARIA Quadrato	REC21171277	
	IMPULSOR	IMPELLER	GIRANTE	CEF500178G	
	TERMOSTATO	THERMOSTAT	TERMOSTATO	REC3840816	
CORREA	BELT	CINGHIA	RM30731809		

Modelo Model Modello	DESCRIPCIÓN	DESCRIPTION	DESCRIZIONE	Ref.
D3, (MY2010+)	FILTRO ACEITE	OIL FILTER	FILTRO OLIO	RM30788490
	FILTRO COMBUSTIBLE	FUEL FILTER	FILTRO COMBUSTIBILE	RM21139810
	FILTRO AIRE	AIR FILTER	FILTRO ARIA	REC21379288
	IMPULSOR	IMPELLER	GIRANTE	CEF500178G
	TERMOSTATO	THERMOSTAT	TERMOSTATO	REC3840816
	CORREA	BELT	CINGHIA	RM30731809
D4 D6	FILTRO ACEITE	OIL FILTER	FILTRO OLIO	REC3582732
	FILTRO ACEITE BY-PASS	OIL FILTER BY-PASS	FILTRO OLIO BY-PASS	REC21632901
	FILTRO COMBUSTIBLE	FUEL FILTER	FILTRO COMBUSTIBILE	REC3583443
	FILTRO CÁRTER	CÁRTER FILTER	FILTRO CÁRTER	RM3584145
	FILTRO AIRE	AIR FILTER	FILTRO ARIA	REC21702999
	IMPULSOR D-4A, D-4D, AQ, IPS	IMPELLER D-4A, D-4D, AQ, IPS	GIRANTE D-4A, D-4D, AQ, IPS	CEF500114T
	IMPULSOR D-4E, D-4F, AQ, IPS	IMPELLER D-4E, D-4F, AQ, IPS	GIRANTE D-4E, D-4F, AQ, IPS	JOH09-1028B
	IMPULSOR D-6A, D-6D, AQ, IPS	IMPELLER D-6A, D-6D, AQ, IPS	GIRANTE D-6A, D-6D, AQ, IPS	JAB17018-0001
	IMPULSOR D-6E, D-6F, AQ, IPS	IMPELLER D-6E, D-6F, AQ, IPS	GIRANTE D-6E, D-6F, AQ, IPS	JOH09-821B
	TERMOSTATO	THERMOSTAT	TERMOSTATO	REC8149182
	CORREA	BELT	CINGHIA	REC3583729

## GUÍA MANTENIMIENTO GASOLINA GASOLINE MAINTENANCE GUIDE GUIDA DI MANUTENZIONE BENZINA



Modelo Model Modello	DESCRIPCIÓN	DESCRIPTION	DESCRIZIONE	Ref.
AQ95 AQ100 AQ110 AQ115 AQ120A AQ130	FILTRO ACEITE	OIL FILTER	FILTRO OLIO	REC3517857
	FILTRO COMBUSTIBLE	FUEL FILTER	FILTRO COMBUSTIBILE	REC3581078
	IMPULSOR	IMPELLER	GIRANTE	JOH09-1026B
	TERMOSTATO	THERMOSTAT	TERMOSTATO	REC876080
	CORREA	BELT	CINGHIA	REC966891
	BUJÍAS	SPARK PLUGS	CANDELE	NGKBP7HS
	AQ170A, B, C	FILTRO ACEITE	OIL FILTER	FILTRO OLIO
FILTRO COMBUSTIBLE		FUEL FILTER	FILTRO COMBUSTIBILE	REC3581078
IMPULSOR		IMPELLER	GIRANTE	JOH09-801B
TERMOSTATO		THERMOSTAT	TERMOSTATO	REC875791
CORREA		BELT	CINGHIA	REC966694
BUJÍAS		SPARK PLUGS	CANDELE	NGKBP7HS
AQ120B AQ125A, B AQ131A, B, C, D 230A, B AQ140A AQ145A, B AQ151A, B, C AQ250, A, B	FILTRO ACEITE	OIL FILTER	FILTRO OLIO	REC3517857
	FILTRO COMBUSTIBLE	FUEL FILTER	FILTRO COMBUSTIBILE	REC3581078
	IMPULSOR	IMPELLER	GIRANTE	JOH09-801B
	TERMOSTATO 82°	THERMOSTAT 82°	TERMOSTATO 82°	REC875580
	CORREA 120A, 120B, 125A, 125B, 140A, 145A	BELT 120A, 120B, 125A, 125B, 140A, 145A	CINGHIA 120A, 120B, 125A, 125B, 140A, 145A	REC966694
	CORREA 130B, C	BELT 130B, C	CINGHIA 130B, C	REC966891
	CORREA 131A, B, C, D, 145B, 151A, B, C	BELT 131A, B, C, D, 145B, 151A, B, C	CINGHIA 131A, B, C, D, 145B, 151A, B, C	REC966382
	BUJÍAS AQ120, 125A 125B, 145	SPARK PLUG AQ120, 125A 125B, 145	CANDELE AQ120, 125A 125B, 145	NGKBP6ES
	BUJÍAS AQ131A, B, C, 140A, 151A, B, C, 230A, 250A, B	SPARK PLUG AQ131A, B, C, 140A, 151A, B, C, 230A, 250A, B	CANDELE AQ131A, B, C, 140A, 151A, B, C, 230A, 250A, B	NGKBP7ES
	AQ255A, B	FILTRO ACEITE	OIL FILTER	FILTRO OLIO
FILTRO COMBUSTIBLE		FUEL FILTER	FILTRO COMBUSTIBILE	REC982230
IMPULSOR AQ255A		IMPELLER AQ255A	GIRANTE AQ255A	SHE09959K
IMPULSOR AQ255B Ancho 31 mm		IMPELLER AQ255B Width 31 mm	GIRANTE AQ255B larghezza 31 mm	JOH09-1027B
IMPULSOR AQ255B Ancho 50 mm		IMPELLER AQ255B Width 50 mm	GIRANTE AQ255B larghezza 50 mm	REC22120-0001
TERMOSTATO 62°		THERMOSTAT 62°	TERMOSTATO 62°	REC876305
CORREA		BELT	CINGHIA	REC978750
BUJÍAS		SPARK PLUG	CANDELE	NGKUR6
AQ225B, C, D, E, F AQ231A, B BB231A	FILTRO ACEITE	OIL FILTER	FILTRO OLIO	REC35-06003
	FILTRO COMBUSTIBLE	FUEL FILTER	FILTRO COMBUSTIBILE	REC982230
	FILTRO COMBUSTIBLE	FUEL FILTER	FILTRO COMBUSTIBILE	REC3581078
	IMPULSOR (B, C)	IMPELLER (B, C)	GIRANTE (B, C)	SHE09959K
	IMPULSOR (D, E, F)	IMPELLER (D, E, F)	GIRANTE (D, E, F)	REC22120-0001
	TERMOSTATO 62°	THERMOSTAT 62°	TERMOSTATO 62°	REC876305
	CORREA Bomba alternador	BELT Alternator pump	CINGHIA Pompe alternatore	REC978750
	CORREA Dirección	BELT Steering	CINGHIA Sterzo	GDY17291
	BUJÍAS AQ225A, B, C, D	SPARK PLUG AQ225A, B, C, D	CANDELE AQ225A, B, C, D	NGKUR6
BUJÍAS AQ225E, F, 231A, B, BB231A	SPARK PLUG AQ225E, F, 231A, B, BB231A	CANDELE AQ225E, F, 231A, B, BB231A	NGKYR5	
AQ260A, B BB260A, B, C	FILTRO ACEITE	OIL FILTER	FILTRO OLIO	REC35-06003
	FILTRO COMBUSTIBLE	FUEL FILTER	FILTRO COMBUSTIBILE	REC982230
	FILTRO COMBUSTIBLE	FUEL FILTER	FILTRO COMBUSTIBILE	REC3581078
	IMPULSOR Ancho 31 mm	IMPELLER Width 31 mm	GIRANTE larghezza 31 mm	JOH09-1027B
	IMPULSOR Ancho 50 mm	IMPELLER Width 50 mm	GIRANTE larghezza 50 mm	REC22120-0001
	TERMOSTATO 62°	THERMOSTAT 62°	TERMOSTATO 62°	REC876305
	CORREA	BELT	CINGHIA	REC978750
	BUJÍAS	SPARK PLUG	CANDELE	NGKBR6FS

Modelo Model Modello	DESCRIPCIÓN	DESCRIPTION	DESCRIZIONE	Ref.	
AQ271A, B, C, D BB261A	FILTRO ACEITE	OIL FILTER	FILTRO OLIO	REC35-06003	
	FILTRO COMBUSTIBLE	FUEL FILTER	FILTRO COMBUSTIBILE	REC855686	
	FILTRO COMBUSTIBLE	FUEL FILTER	FILTRO COMBUSTIBILE	REC3581078	
	IMPULSOR Ancho 31 mm	IMPELLER Width 31 mm	GIRANTE larghezza 31 mm	JOH09-1027B	
	IMPULSOR Ancho 50 mm	IMPELLER Width 50 mm	GIRANTE larghezza 50 mm	REC22120-0001	
	TERMOSTATO 62°	THERMOSTAT 62°	TERMOSTATO 62°	REC876305	
	CORREA Bomba alternador	BELT pump alternator	CINGHIA Pompa alternatore	REC978750	
	CORREA Dirección	BELT Steering	CINGHIA Sterzo	REC967111	
	BUJÍAS	SPARK PLUG	CANDELE	NGKBR6FS	
430, 431, 432, 434	FILTRO ACEITE	OIL FILTER	FILTRO OLIO	REC35-06004	
	FILTRO COMBUSTIBLE	FUEL FILTER	FILTRO COMBUSTIBILE	REC855686	
	FILTRO COMBUSTIBLE	FUEL FILTER	FILTRO COMBUSTIBILE	REC3581078	
	IMPULSOR Ancho 31 mm	IMPELLER Width 31 mm	GIRANTE larghezza 31 mm	JOH09-1027B	
	IMPULSOR Ancho 50 mm	IMPELLER Width 50 mm	GIRANTE larghezza 50 mm	REC22120-0001	
	TERMOSTATO 62°	THERMOSTAT 62°	TERMOSTATO 62°	REC876305	
	CORREA Bomba alternador	BELT pump alternator	CINGHIA Pompa alternatore	REC978750	
	CORREA Dirección	BELT Steering	CINGHIA Sterzo	REC967111	
	BUJÍAS	SPARK PLUG	CANDELE	NGKBR6FS	
AQ280A AQ290A	FILTRO ACEITE	OIL FILTER	FILTRO OLIO	REC35-06003	
	FILTRO COMBUSTIBLE	FUEL FILTER	FILTRO COMBUSTIBILE	REC982230	
	FILTRO COMBUSTIBLE	FUEL FILTER	FILTRO COMBUSTIBILE	REC3581078	
	IMPULSOR Ancho 31 mm	IMPELLER Width 31 mm	GIRANTE larghezza 31 mm	JOH09-1027B	
	IMPULSOR Ancho 50 mm	IMPELLER Width 50 mm	GIRANTE larghezza 50 mm	REC22120-0001	
	TERMOSTATO 62°	THERMOSTAT 62°	TERMOSTATO 62°	REC876305	
	CORREA	BELT	CINGHIA	REC978750	
	BUJÍAS AQ280A	SPARK PLUGS AQ280A	CANDELE AQ280A	NGKUR6	
	BUJÍAS AQ290A, B	SPARK PLUGS AQ290A, B	CANDELE AQ290A, B	NGKBR6FS	
AQ311A, B	FILTRO ACEITE	OIL FILTER	FILTRO OLIO	REC35-06003	
	FILTRO COMBUSTIBLE	FUEL FILTER	FILTRO COMBUSTIBILE	REC855686	
	FILTRO COMBUSTIBLE	FUEL FILTER	FILTRO COMBUSTIBILE	REC3581078	
	IMPULSOR Ancho 31 mm	IMPELLER Width 31 mm	GIRANTE larghezza 31 mm	JOH09-1027B	
	IMPULSOR Ancho 50 mm	IMPELLER Width 50 mm	GIRANTE larghezza 50 mm	REC22120-0001	
	TERMOSTATO 62°	THERMOSTAT 62°	TERMOSTATO 62°	REC876305	
	CORREA	BELT	CINGHIA	REC978750	
	BUJÍAS	SPARK PLUGS	CANDELE	NGKBR6FS	
	500A, B 501A, B	FILTRO ACEITE	OIL FILTER	FILTRO OLIO	REC35-06003
FILTRO COMBUSTIBLE		FUEL FILTER	FILTRO COMBUSTIBILE	REC855686	
FILTRO COMBUSTIBLE		FUEL FILTER	FILTRO COMBUSTIBILE	REC3581078	
IMPULSOR Ancho 31 mm		IMPELLER Width 31 mm	GIRANTE larghezza 31 mm	JOH09-1027B	
TERMOSTATO 62°		THERMOSTAT 62°	TERMOSTATO 62°	REC876305	
CORREA Bomba alternador		BELT pump alternator	CINGHIA pompa alternatore	REC978750	
CORREA Dirección		BELT steering	CINGHIA sterzo	REC967111	
BUJÍAS		Spark Plugs	CANDELE	NGKBR6FS	
570A 571A 572A		FILTRO ACEITE	OIL FILTER	FILTRO OLIO	REC35-06003
	FILTRO COMBUSTIBLE	FUEL FILTER	FILTRO COMBUSTIBILE	REC855686	
	IMPULSOR Ancho 31 mm	IMPELLER Width 31 mm	GIRANTE larghezza 31 mm	JOH09-1027B	
	IMPULSOR Ancho 50 mm	IMPELLER Width 50 mm	GIRANTE larghezza 50 mm	CEF500104	
	TERMOSTATO 62°	THERMOSTAT 62°	TERMOSTATO 62°	REC876305	
	CORREA Bomba alternador	BELT pump alternator	CINGHIA pompa alternatore	REC978750	
	CORREA Dirección	BELT steering	CINGHIA sterzo	REC967111	
	BUJÍAS	SPARK PLUGS	CANDELE	NGKBR6FS	
	740A, B	FILTRO ACEITE	OIL FILTER	FILTRO OLIO	REC35-06003
FILTRO COMBUSTIBLE		FUEL FILTER	FILTRO COMBUSTIBILE	REC855686	
IMPULSOR		IMPELLER	GIRANTE	CEF500104	
TERMOSTATO 62°		THERMOSTAT 62°	TERMOSTATO 62°	REC876305	
CORREA		BELT	CINGHIA	RM967191	
BUJÍAS		SPARK PLUGS	CANDELE	NGKBR6FS	
7.4GL		FILTRO ACEITE	OIL FILTER	FILTRO OLIO	RM3850559
		FILTRO COMBUSTIBLE	FUEL FILTER	FILTRO COMBUSTIBILE	REC3862228
		IMPULSOR (MD)	IMPELLER (MD)	GIRANTE (MD)	SHE09959K
	IMPULSOR (HU, NC, LK)	IMPELLER (HU, NC, LK)	GIRANTE (HU, NC, LK)	JOH09-1027B	
	TERMOSTATO	THERMOSTAT	TERMOSTATO	REC3853983	
	CORREA	BELT	CINGHIA	RM3850430	
	BUJÍAS	SPARK PLUGS	CANDELE	CHARV15YC4	
	7.4GI, GSI DPX385	FILTRO ACEITE	OIL FILTER	FILTRO OLIO	RM3850559
		FILTRO COMBUSTIBLE	FUEL FILTER	FILTRO COMBUSTIBILE	REC3862228
IMPULSOR		IMPELLER	GIRANTE	JOH09-1027B	
TERMOSTATO		THERMOSTAT	TERMOSTATO	REC3853983	
CORREA alternador (BY, WT, MD, HU, NC, LK)		BELT alternator (BY, WT, MD, HU, NC, LK)	CINGHIA alternatore (BY, WT, MD, HU, NC, LK)	RM3854643	
CORREA Dirección (MD, HU, NC, LK)		BELT steering (MD, HU, NC, LK)	CINGHIA sterzo (MD, HU, NC, LK)	RM3860087	
BUJÍAS		SPARK PLUGS	CANDELE	NGKBR6FS	
BUJÍAS IRIIDIUM		SPARK PLUGS IRIIDIUM	CANDELE IRIIDIUM	NGKUR6IX	
8.2GL, GSI DPX415		FILTRO ACEITE	OIL FILTER	FILTRO OLIO	RM3850559
	FILTRO COMBUSTIBLE	FUEL FILTER	FILTRO COMBUSTIBILE	REC3862228	
	IMPULSOR (8.2GL)	IMPELLER (8.2GL)	GIRANTE (8.2GL)	SHE09959K	
	IMPULSOR (GSI, DPX HU-BY, WT)	IMPELLER (GSI, DPX HU-BY, WT)	GIRANTE MOD. GSI/DPX HU-BY, WT	JOH09-1027B	
	TERMOSTATO	THERMOSTAT	TERMOSTATO	REC3853983	
	CORREA	BELT	CINGHIA	RM3852607	
	CORREA Bomba (LK, BY, WT)	BELT pump (LK, BY, WT)	CINGHIA pompe (LK, BY, WT)	RM978454	
	CORREA alternador (LK, BY, WT)	BELT alternator (LK, BY, WT)	CINGHIA alternatore (LK, BY, WT)	RM3854643	
	CORREA (PNCA, PNVM)	BELT (PNCA, PNVM)	CINGHIA (PNCA, PNVM)	RM3850430	
	CORREA (EF)	BELT (EF)	CINGHIA (EF)	RM3860087	
	BUJÍAS	SPARK PLUGS	CANDELE	NGKBR6FS	
BUJÍAS IRIIDIUM	SPARK PLUGS IRIIDIUM	CANDELE IRIIDIUM	NGKBR6FIX		

Modelo Modelo Modelo	DESCRIPCIÓN	DESCRIPTION	DESCRIZIONE	Ref.
3.0GLP-C, D, E, J	FILTRO ACEITE	OIL FILTER	FILTRO OLIO	REC35-06003
	FILTRO COMBUSTIBLE	FUEL FILTER	FILTRO COMBUSTIBILE	REC3847644
	IMPULSOR (C)	IMPELLER (C)	GIRANTE (C)	JOH09-1027B
	IMPULSOR (D, E, J)	IMPELLER (D, E, J)	GIRANTE (D, E, J)	JOH09-812B
	TERMOSTATO	THERMOSTAT	TERMOSTATO	REC3853799
	CORREA alternador (C, D)	BELT alternator (C, D)	CINGHIA alternatore (C, D)	RM3586325
	CORREA Dirección (E)	BELT Steering (E)	CINGHIA sterzo (E)	REC3860092
	CORREA (J)	BELT (J)	CINGHIA (J)	REC3888177
	BUJÍAS	SPARK PLUGS	CANDELE	NGKBPR6EFS
3.0GXI-J 3.0GXIC-J	FILTRO ACEITE	OIL FILTER	FILTRO OLIO	REC35-06003
	FILTRO COMBUSTIBLE	FUEL FILTER	FILTRO COMBUSTIBILE	REC3847644
	IMPULSOR	IMPELLER	GIRANTE	JOH09-812B
	CORREA	BELT	CINGHIA	REC21132392
	BUJÍAS	SPARK PLUGS	CANDELE	NGKBPR6EFS
4.3GL-J, GL-JF, GXI-J, GXI-JF, OSI-J, OSI-JF	FILTRO ACEITE	OIL FILTER	FILTRO OLIO	REC8692305
	FILTRO COMBUSTIBLE (GL-J, GL-JF)	FUEL FILTER (GL-J, GL-JF)	FILTRO COMBUSTIBILE (GL-J, GL-JF)	REC3862228
	FILTRO COMBUSTIBLE (GXI, OSI)	FUEL FILTER (GXI, OSI)	FILTRO COMBUSTIBILE (GXI, OSI)	REC3847644
	IMPULSOR	IMPELLER	GIRANTE	JOH09-812B
	TERMOSTATO	THERMOSTAT	TERMOSTATO	REC3587597
	TERMOSTATO Agua Dulce	THERMOSTAT Fresh Water	TERMOSTATO acqua dolce	REC3831426
	CORREA	BELT	CINGHIA	RM21132390
	BUJÍAS	SPARK PLUGS	CANDELE	NGKBPR6EFS
	BUJÍAS IRIIDIUM	SPARK PLUGS IRIIDIUM	CANDELE IRIIDIUM	NGKUR6IX
	4.3GXI-G, GXI-GF, OSI-G, OSI-GF	FILTRO ACEITE	OIL FILTER	FILTRO OLIO
FILTRO COMBUSTIBLE		FUEL FILTER	FILTRO COMBUSTIBILE	REC3862228
IMPULSOR		IMPELLER	GIRANTE	JOH09-812B
TERMOSTATO (GF)		THERMOSTAT (GF)	TERMOSTATO (GF)	REC3831426
TERMOSTATO (G)		THERMOSTAT (G)	TERMOSTATO (G)	REC3587597
CORREA		BELT	CINGHIA	RM3889124
BUJÍAS		SPARK PLUGS	CANDELE	NGKBPR6EFS
BUJÍAS IRIIDIUM		SPARK PLUGS IRIIDIUM	CANDELE IRIIDIUM	NGKUR6IX
5.0GL-J, GL-JF, GXI-J, GXI-JF, OSI-J, OSI-JF	FILTRO ACEITE	OIL FILTER	FILTRO OLIO	REC8692305
	FILTRO COMBUSTIBLE (GL)	FUEL FILTER (GL)	FILTRO COMBUSTIBILE (GL)	REC3862228
	FILTRO COMBUSTIBLE (GXI, OSI)	FUEL FILTER (GXI, OSI)	FILTRO COMBUSTIBILE (GXI, OSI)	REC3847644
	IMPULSOR	IMPELLER	GIRANTE	JOH09-812B
	TERMOSTATO	THERMOSTAT	TERMOSTATO	REC3587597
	TERMOSTATO Agua Dulce	THERMOSTAT Fresh Water	TERMOSTATO acqua dolce	REC3831426
	CORREA	BELT	CINGHIA	RM21132390
	BUJÍAS	Spark Plugs	CANDELE	NGKBPR6EFS
BUJÍAS IRIIDIUM	Spark Plugs IRIIDIUM	CANDELE IRIIDIUM	NGKUR6IX	
5.0GXI-G, GXI-GF, OSI-G, OSI-GF	FILTRO ACEITE	OIL FILTER	FILTRO OLIO	REC35-06003
	FILTRO COMBUSTIBLE	FUEL FILTER	FILTRO COMBUSTIBILE	REC3862228
	IMPULSOR	IMPELLER	GIRANTE	JOH09-812B
	TERMOSTATO	THERMOSTAT	TERMOSTATO	REC3831426
	CORREA	BELT	CINGHIA	RM3889124
	BUJÍAS	SPARK PLUGS	CANDELE	NGKBPR6EFS
	BUJÍAS IRIIDIUM	SPARK PLUGS IRIIDIUM	CANDELE IRIIDIUM	NGKUR6IX
	5.7GI-F, GI-FF, GXI-G, GXI-GF, OSI-E, OSI-FF	FILTRO ACEITE	OIL FILTER	FILTRO OLIO
FILTRO COMBUSTIBLE		FUEL FILTER	FILTRO COMBUSTIBILE	REC3862228
IMPULSOR		IMPELLER	GIRANTE	JOH09-812B
TERMOSTATO		THERMOSTAT	TERMOSTATO	REC3587597
TERMOSTATO agua dulce		THERMOSTAT fresh water	TERMOSTATO acqua dolce	REC3831426
CORREA		BELT	CINGHIA	RM3889124
BUJÍAS		SPARK PLUGS	CANDELE	NGKBPR6EFS
BUJÍAS IRIIDIUM		SPARK PLUGS IRIIDIUM	CANDELE IRIIDIUM	NGKUR6IX
5.7GI300-J, GI300-JF 5.7OSI-J, OSI-JF 5.7GXI-J, GXI-JF 5.7OSXI-J, OSXI-JF	FILTRO ACEITE	OIL FILTER	FILTRO OLIO	REC8692305
	FILTRO COMBUSTIBLE	FUEL FILTER	FILTRO COMBUSTIBILE	REC3847644
	IMPULSOR	IMPELLER	GIRANTE	JOH09-812B
	TERMOSTATO	THERMOSTAT	TERMOSTATO	REC3587597
	TERMOSTATO agua dulce	THERMOSTAT fresh water	TERMOSTATO acqua dolce	REC3831426
	CORREA	BELT	CINGHIA	RM21132390
	BUJÍAS	SPARK PLUGS	CANDELE	NGKBPR6EFS
	BUJÍAS IRIIDIUM	SPARK PLUGS IRIIDIUM	CANDELE IRIIDIUM	NGKUR6IX
8.1GI-J, GI-JF 8.1GXI-J, GXI-JF 8.1OSI-J, OSI-JF	FILTRO ACEITE	OIL FILTER	FILTRO OLIO	REC8692305
	FILTRO COMBUSTIBLE	FUEL FILTER	FILTRO COMBUSTIBILE	REC3847644
	IMPULSOR	IMPELLER	GIRANTE	JOH09-812B
	TERMOSTATO	THERMOSTAT	TERMOSTATO	REC3853983
	TERMOSTATO agua dulce	THERMOSTAT fresh water	TERMOSTATO acqua dolce	REC3831426
	CORREA	BELT	CINGHIA	RM21132385
	BUJÍAS	SPARK PLUGS	CANDELE	NGKBPR6EFS
	BUJÍAS IRIIDIUM	SPARK PLUGS IRIIDIUM	CANDELE IRIIDIUM	NGKUR6IX
8.1GI-H, GI-HF 8.1GXI-G, GXI-GF 8.1OSI-D, OSI-DF	FILTRO ACEITE	OIL FILTER	FILTRO OLIO	REC35-06003
	FILTRO COMBUSTIBLE	FUEL FILTER	FILTRO COMBUSTIBILE	REC3847644
	IMPULSOR	IMPELLER	GIRANTE	JOH09-812B
	TERMOSTATO	THERMOSTAT	TERMOSTATO	REC3853983
	TERMOSTATO agua dulce	THERMOSTAT fresh water	TERMOSTATO acqua dolce	REC3831426
	CORREA	BELT	CINGHIA	RM21132390
	BUJÍAS	SPARK PLUGS	CANDELE	NGKBPR6EFS
	BUJÍAS IRIIDIUM	SPARK PLUGS IRIIDIUM	CANDELE IRIIDIUM	NGKUR6IX

# GUÍA DE ÁNODOS DE COLAS

## DRIVES ANODES GUIDE

### GUIDA ANODI PIEDI

Modelo Model Modello			ZN	R.O OEM	AL	R.O OEM
AQUAMATIC 1 hélice Single prop drives 1 elica	ENGRANAJE INFERIOR LOWER GEAR INGRANAGGIO INFERIORE	100	CMV-15	875810		
		200 - 290 SP	CMCMV-18	875815	CMCMV-18A	
	PLACA / ALETA SPRAY PLATE PIASTRA / ALETTA	SX	CM3855411	3855411	CM3855411A	3863193
		SX-A	CM3883728	3888814	CM3883728A	3888813
	TRANSOM	200-280	CM832598	832598	CM832598A	
		290, SP	CM852835	852835	CM852835A	
SX		CM3854130	3854130	CM3854130A	3586461	
SX-A		CM3841427	3841427	CM3841427A	3888816	
AQUAMATIC 2 hélices Duoprop drives 2 eliche	ENGRANAJE INFERIOR LOWER GEAR INGRANAGGIO INFERIORE	280, 290, DP	CM875821	875821	CM875821A	
	PLACA / ALETA SPRAY PLATE PIASTRA / ALETTA	DPS	CM3855411	3855411	CM3855411A	3863193
		DPS-A, DPS-B, FWD	CM3883728	3888814	CM3883728	3888813
		DPH	CM3588746	3588746	CM3588746A	3588748
		DPR	TEN00733BIS	3589875		
	TRANSOM	DPX	CM876638	876638		
		280	CM832598	832598	CM832598A	
		290, DP	CM852835	352835	CM852835A	
		DPS	CM3854130	3854130	CM3854130	3586461
		DPS-A, DPS-B, FWD	CM3841427	3888817	CM3841427A	3888816
DPH, DPR		CM3588745	3588745	CM3588745A	3588770	
DPX	CM872139	872139	CM872139A			
PENTA IPS	ENGRANAJE INFERIOR LOWER GEAR INGRANAGGIO INFERIORE		CM3593881	3593981		
	TRANSOM IPS	1 15, 2, 3, 30			TEN00739AL	23172849 23172856
S-DRIVE	ENGRANAJE INFERIOR LOWER GEAR INGRANAGGIO INFERIORE	110S, 120S, MS25S 130S, 150S (2 UN)	CM851983 CM3888305	876286 22651246	CM851983A CM3888305A	
	S-DRIVE	2 PALAS / BLADES / PALE	CM3858399	3858399	CM3858399A	
3 PALAS / BLADES / PALE		CM3858399	3858399	CM3858399A		
4 PALAS / BLADES / PALE		TEN00728BIS	3584442			
FOLDING PROPELLER	EJE SHAFT ASSE	4 PALAS / BLADES / PALE	TEN00728BIS	3584442		

# GUÍA MANTENIMIENTO COLAS

## DRIVES MAINTENANCE GUIDE

### GUIDA DI MANUTENZIONE PIEDE

Modelo Model Modello	DESCRIPCIÓN	DESCRIPTION	DESCRIZIONE	Ref.	R.O OEM
110S	PLACA CUBIERTA CONTRA CASCO RETÉN DE GOMA	COVER PLATE AGAINST HULL RUBBER SEAL	COPERCHIO PIATTO CONTRO SCAFO PARAOLIO IN GOMMA	CEF501001	22303438 21389074
120S, S-B, S-C, S-D, S-E	PLACA CUBIERTA CONTRA CASCO RETÉN DE GOMA	COVER PLATE AGAINST HULL RUBBER SEAL	COPERCHIO PIATTO CONTRO SCAFO PARAOLIO IN GOMMA	CEF501001	854932 21389074
270 270T	FUELLE TRANSON	DRIVE JOINT BELLOW	CUFFIA TRANSON	REC876294	876294
	MANGUITO (270)	COOLANT HOSE (270)	MANICOTTO (270)	REC875822	875822
	FUELLE ESCAPE	EXHAUST BELLOW	CUFFIA SCARICO	REC876631	876631
280 280TA, PT	FUELLE TRANSON	DRIVE JOINT BELLOW	CUFFIA TRANSON	REC876294	876294
	MANGUITO (280, PT)	COOLANT HOSE (280, PT)	MANICOTTO (280, PT)	REC875822	875822
	FUELLE ESCAPE	EXHAUST BELLOW	CUFFIA SCARICO	REC876633	876633
280DP	FUELLE TRANSON	DRIVE JOINT BELLOW	CUFFIA TRANSON	REC876294	876294
	MANGUITO	COOLANT HOSE	MANICOTTO	REC875822	875822
	FUELLE ESCAPE	EXHAUST BELLOW	CUFFIA SCARICO	REC876631	876631
290, A 290SP-A, A1, A2, C, C1, E 290DP, A, A1, A2, B, B1, C, C1, D, D1, E	FUELLE TRANSON	DRIVE JOINT BELLOW	CUFFIA TRANSON	REC876294	876294
	MANGUITO	COOLANT HOSE	MANICOTTO	CEF501002	876632
	FUELLE ESCAPE	EXHAUST BELLOW	CUFFIA SCARICO	REC876631	876631
DPX-S, S1, R, A, G	FUELLE TRANSON	DRIVE JOINT BELLOW	CUFFIA TRANSON	REC876294	876294
	FUELLE TRANSON (A, AG)	DRIVE JOINT BELLOW (A, AG)	CUFFIA TRANSON (A, AG)	REC3860384	3860384
	MANGUITO	COOLANT HOSE	MANICOTTO	CEF501002	876632
	FUELLE ESCAPE	EXHAUST BELLOW	CUFFIA SCARICO	REC876631	876631
DPH-A, B, C DPR-A	FUELLE TRANSON	DRIVE JOINT BELLOW	CUFFIA TRANSON	REC3808898	3594509
	KIT FUELLE (CILINDROS DIRECCIÓN)	ANTI-BARNACLE BELLOW KIT (STEERING CYLINDERS)	KIT CUFFIE (CILINDRI STERZO)	RM21132674	21132674
	FUELLE ESCAPE	EXHAUST BELLOW	CUFFIA SCARICO	CEF500538K	3588753
SX-M DP-SM XDP	KIT FUELLE ESCAPE (SX-M)	BELLOW KIT, EXHAUST (SX-M)	KIT CUFFIA, SCARICO (SX-M)	REC3850426	3850426
	KIT FUELLE (XDP)	BELLOW KIT, DRIVE (XDP)	KIT CUFFIA (XDP)	RM21277185	21277185
	KIT FUELLE ESCAPE (XDP)	BELLOW KIT, EXHAUST (XDP)	KIT CUFFIA, SCARICO (XDP)	RM3885870	388587
SX DPS	FUELLE TRANSON	DRIVE JOINT BELLOW	CUFFIA TRANSON	REC3841481	22197130
	FUELLE ESCAPE	EXHAUST BELLOW	CUFFIA SCARICO	REC3850426	3850426
SX-A DPS-A, B	FUELLE TRANSON	DRIVE JOINT BELLOW	CUFFIA TRANSON	RM22197130	22197130
	FUELLE ESCAPE	EXHAUST BELLOW	CUFFIA SCARICO	REC3888916	3888916
DPG	FUELLE TRANSON	DRIVE JOINT BELLOW	CUFFIA TRANSON	REC876294	876294
	FUELLE TRANSON (A, AG)	DRIVE JOINT BELLOW (A, G)	CUFFIA TRANSON (A, AG)	REC3860384	3860384
	MANGUITO	COOLANT HOSE	MANICOTTO	CEF501002	876632

# KITS MANTENIMIENTO COLAS DRIVES AMINTENANCE KIT KIT MANUTENZIONE PIEDE

**NEW**

COLA DRIVE PIEDE	REF	COMPONENTES COMPONENTS COMPONENTI	DESCRIPCIÓN	DESCRIPTION	DESCRIZIONE	UNID UNITS UNITA
SX-A	RECKITSXA	CEF500536K	FUELLE ESCAPE	EXHAUST BELOW	MANICOTTO SCARICO	1
		CMSXAKITA	KIT ÁNODOS AL	ANODES KIT AL	KIT ANODI AL	1
		RM22197130	FUELLE TRANSMISION	BELLOWS	MANICOTTO TRASMISSIONE	1
SP-E	RECKITSPE	REC876294	FUELLE TRANSON	BELOW	MANICOTTO TRANSON	1
		REC876631	FUELLE ESCAPE	EXHAUST BELOW	MANICOTTO SCARICO	1
		CM290KITA	KIT ÁNODOS AL	ANODES KIT AL	KIT ANODI AL	1
		REC17276	PIN	PIN	FERMO	1
		REC872096	CASQUILLOS HORQUILLA	TILT BUSHING	GHIERA FORCELLA	2
		REC897682	JUNTA	GASKET	GUARNIZIONE	1
		REC955974	ARO TÓRICO	O-RING	FASCIA TONDA	1
		REC955989	ARO TÓRICO	O-RING	FASCIA TONDA	1
		REC25-30613	ARO TÓRICO	O-RING	FASCIA TONDA	2
DPS-SX	RECKITDPS-SX	REC3850426	FUELLE ESCAPE	EXHAUST BELOW	MANICOTTO SCARICO	1
		REC3852045	ARO TÓRICO	O-RING	FASCIA TONDA	1
		CMSXKITA	KIT ÁNODOS AL	ANODES KIT AL	KIT ANODI AL	1
		REC3852056	PIN	PIN	FERMO	1
		REC3852560	RETEN GOMA	RUBBER SEAL	PARAOLIO GOMMA	1
		REC3855081	JUNTA	GASKET	GUARNIZIONE	1
		REC955981	ARO TÓRICO	O-RING	FASCIA TONDA	1
		REC3841481	FUELLE TRANSON	U-JOINT BELOW	CUFFIA TRANSON	1
		CEF500537K	FUELLE TRANSMISION	BELLOWS	MANICOTTO TRASMISSIONE	1
DPR	RECKITDPR	CEF500538K	FUELLE ESCAPE	EXHAUST BELOW	MANICOTTO SCARICO	1
		CM3588745	ÁNODO	ANODE	ANODO	1
		TEN00733BIS	ÁNODO	ANODE	ANODO	1
		CEF500537K	FUELLE TRANSMISION	BELLOWS	MANICOTTO TRASMISSIONE	1
DPH	RECKITDPH	CEF500538K	FUELLE ESCAPE	EXHAUST BELOW	MANICOTTO SCARICO	1
		CMDPHKITA	KIT ÁNODOS AL	ANODES KIT AL	KIT ANODI AL	1
		REC876294	FUELLE TRANSON	BELOW KIT	MANICOTTO TRANSON	1
DPC-D-E	RECKITDPC-D-E	REC876631	FUELLE ESCAPE	EXHAUST BELOW	MANICOTTO SCARICO	1
		CM290KITA	KIT ÁNODOS AL	ANODES KIT AL	KIT ANODI AL	1
		CM290DPKITA	KIT ÁNODOS AL	ANODES KIT AL	KIT ANODI AL	1
		REC17276	PIN	PIN	FERMO	1
		REC872096	CASQUILLOS HORQUILLA	TILT BUSHING	GHIERA FORCELLA	2
		REC897682	JUNTA	GASKET	GUARNIZIONE	1
		REC955974	ARO TÓRICO	O-RING	FASCIA TONDA	1
		REC955989	ARO TÓRICO	O-RING	FASCIA TONDA	1
		REC876294	FUELLE TRANSON	BELOW KIT	MANICOTTO TRANSON	1
290SP	RECKIT290SP	REC876631	FUELLE ESCAPE	EXHAUST BELOW	MANICOTTO SCARICO	1
		CM290KITA	KIT ÁNODOS AL	ANODES KIT AL	KIT ANODI AL	1
		REC17276	PIN	PIN	FERMO	1
		REC125017	ARO TÓRICO	O-RING	FASCIA TONDA	1
		REC876278	CASQUILLOS HORQUILLA	PLASTIC BUSHING	GHIERA FORCELLA	2
		REC876279	CASQUILLOS HORQUILLA	TILT BUSHING	GHIERA FORCELLA	2
		REC897682	JUNTA	GASKET	GUARNIZIONE	1
		REC955974	ARO TÓRICO	O-RING	FASCIA TONDA	1
		REC955989	ARO TÓRICO	O-RING	FASCIA TONDA	1
290DP	RECKIT290DP	REC876294	FUELLE TRANSON	BELOW KIT	MANICOTTO TRANSON	1
		REC876631	FUELLE ESCAPE	EXHAUST BELOW	MANICOTTO SCARICO	1
		CM290DPKITA	KIT ÁNODOS AL	ANODES KIT AL	KIT ANODI AL	1
		REC17276	PIN	PIN	FERMO	1
		REC876278	CASQUILLOS HORQUILLA	PLASTIC BUSHING	GHIERA FORCELLA	2
		REC876279	CASQUILLOS HORQUILLA	TILT BUSHING	GHIERA FORCELLA	2
		REC897682	JUNTA	GASKET	GUARNIZIONE	1
		REC955974	ARO TÓRICO	O-RING	FASCIA TONDA	1
		REC955989	ARO TÓRICO	O-RING	FASCIA TONDA	1
280DP	RECKIT280DP	REC876294	FUELLE TRANSON	BELOW KIT	MANICOTTO TRANSON	1
		REC876631	FUELLE ESCAPE	EXHAUST BELOW	MANICOTTO SCARICO	1
		CM280DPKITA	KIT ÁNODOS AL	ANODES KIT AL	KIT ANODI AL	1
		REC17276	PIN	PIN	FERMO	1
		REC876278	CASQUILLOS HORQUILLA	PLASTIC BUSHING	GHIERA FORCELLA	2
		REC897682	JUNTA	GASKET	GUARNIZIONE	1
REC955974	ARO TÓRICO	O-RING	FASCIA TONDA	1		
REC955989	ARO TÓRICO	O-RING	FASCIA TONDA	1		

**NEW**





# ACEITE PARA MOTOR ENGINE OIL OLIO PER MOTORE

## SYNTHETIC PETROL

REF	R.O. OEM		VISCOSIDAD VISCOSITY VISCOSITA	GRADO GRADE GRADE
REC21363429	21363429	1 L	SAE 5W40	API SM
REC21363430	21363430	5 L		

Especialmente desarrollado para motores de alto rendimiento. Las propiedades especiales de este aceite le permiten lubricar el motor incluso durante el arranque a baja temperatura. El aceite combate la acumulación de lodo y brinda una excelente protección contra el desgaste. Especialmente adecuado para motores que están sujetos a arranques y paradas frecuentes.

Specially developed for high performance engines. The special properties of this oil allow it to lubricate the engine even during low temperature starting. The oil combats sludge build-up and gives excellent protection against wear. Particularly suitable for engines that are subject to frequent starting and stopping.

Sviluppato appositamente per motori ad alte prestazioni. Le proprietà speciali di questo olio consentono di lubrificare il motore anche durante l'avviamento a bassa temperatura. L'olio combatte il fango accumulato e offre un'eccellente protezione contro l'usura. Particolarmente adatto per motori soggetti a frequenti avviamenti e arresti.



REC21363429



REC21363430

## VDS-3. MINERAL

REF	R.O. OEM		VISCOSIDAD VISCOSITY VISCOSITA	GRADO GRADE GRADE
REC22479638	22479638	1 L	SAE 15W-40	Mineral oil VDS-3 API CI-4 ACEA E5
REC22479642	22479642	5 L		

VDS-3 cubre los requisitos más estrictos sobre la limpieza del pistón en comparación con VDS-2, lo que garantiza la durabilidad y fiabilidad de los motores. La alta calidad del aceite VDS-3 permite en ciertos casos un aumento en los intervalos de drenaje. Para motores diesel y de gasolina (ver manuales de los operadores).

VDS-3 covers even more stringent requirements on piston cleanliness and bore polish compared to VDS-2, ensuring the durability and reliability of the engines. The high quality of VDS-3 oil allows in certain cases an increase in drain intervals. Fits both diesel and gas engines (check operators manuals).

VDS-3 copre requisiti ancora più stringenti sulla pulizia del pistone e sulla lucidatura del foro rispetto a VDS-2, garantendo la durata e l'affidabilità dei motori. L'alta qualità dell'olio VDS-3 consente in certi casi un aumento degli intervalli di scarico. Adatto sia ai motori diesel che a quelli a gas (consultare i manuali degli operatori).



REC22479638



REC22479642

## SYNTHETIC MARINE TRANSMISSION OIL

### IPS, Aquamatic

REF	R.O. OEM		VISCOSIDAD VISCOSITY VISCOSITA
REC22479650	22479650	1 L	SAE 75W-90
REC22479648	22479648	5 L	

### DHP (ratio 1.59:1 (D6-400) DPG (KAD300)

REF	R.O. OEM		VISCOSIDAD VISCOSITY VISCOSITA
REC22574246	22574246	5 L	SAE 75W-140

Aceite de transmisión marina de alto rendimiento diseñado para proporcionar la máxima protección para las colas Volvo Penta IPS y Aquamatic. Específicamente formulado para ofrecer un excelente rendimiento bajo cargas y temperaturas extremas a la vez que proporciona propiedades de fricción equilibradas entre agarre y deslizamiento y máxima protección contra el desgaste y la corrosión. La tecnología avanzada de los aditivos incluye una capacidad única para minimizar el daño debido a la contaminación del agua.

Todo esto asegura ventajas significativas sobre los aceites de transmisión convencionales y contribuye a un funcionamiento suave y de alto rendimiento y a la salud a largo plazo de la cola.

High performance marine transmission oil designed to provide maximum protection for Volvo Penta IPS and Aquamatic sterndrives. Specifically formulated to offer excellent performance under extreme loads and temperatures while providing balanced frictional properties between grip and slip and maximum protection against wear and corrosion. Advanced additive technology include unique capability to minimize damage due to water contamination.

All this ensure significant advantages over conventional transmission oils and contributes to high-performance, smooth operation and longterm health of the drive.

Olio per trasmissioni marine ad alte prestazioni progettato per fornire la massima protezione per Volvo Penta IPS e entrofuoribordo Aquamatic. Specificamente formulato per offrire prestazioni eccellenti in presenza di carichi e temperature estreme, fornendo al tempo stesso proprietà di attrito bilanciate tra aderenza e scivolamento e massima protezione contro l'usura e la corrosione. La tecnologia additiva avanzata include la capacità unica di minimizzare i danni dovuti alla contaminazione dell'acqua.

Tutto ciò garantisce vantaggi significativi rispetto agli oli di trasmissione convenzionali e contribuisce a garantire prestazioni elevate, funzionamento regolare e integrità a lungo termine del piede.



REC22479650



REC22479648



REC22574246

**TRANSMISSION OIL**

REF	R.O. OEM	VISCOSIDAD VISCOSITY VISCOSITÀ	GRADO GRADE GRADE
REC3809445	3809445	5 L SAE 80W-90	API GL-5

Las propiedades de lubricación protegen el accionamiento y la transmisión incluso bajo cargas pesadas. También proporciona una excelente protección contra la corrosión. Soporta altas temperaturas sin romperse.

Lubrication properties protect drive and transmission even under heavy load. Also provides excellent corrosion protection. Withstands high temperatures without breaking down.

Le proprietà di lubrificazione proteggono l'azione e la trasmissione anche sotto carico pesante. Offre inoltre un'eccellente protezione dalla corrosione. Resiste alle alte temperature senza rompersi.



**NEW**

**COMPRESSOR OIL**

REF	R.O. OEM	VISCOSIDAD VISCOSITY VISCOSITÀ
RM85108974	85108974	250 ml ISO VG 68

Especialmente probado en compresores Volvo Penta. Completamente sintético, resiste temperaturas altas y bajas. Protege el compresor contra la corrosión.

Specially tested in Volvo Penta compressors. Fully synthetic oil that withstands both high and low temperatures. Protects compressor against corrosion.

Testati appositamente con i compressori Volvo Penta. Olio completamente sintetico che resiste alle alte e alle basse temperature. Protegge il compressore dalla corrosione.



**NEW**

**ATF-OIL, type DEXRON III**

REF	R.O. OEM	VISCOSIDAD VISCOSITY VISCOSITÀ
REC85122800	85122800	1 L
REC1161995	1161995	5 L

Protege contra el desgaste, incluso a altas temperaturas. También proporciona muy buena protección contra la corrosión.

NO DEBE USARSE DONDE SE RECOMIENDA API-GL5

Protects against wear, even at high temperatures. Also provides a very good corrosion protection.

MUST NOT BE USED WHERE API-GL5 IS RECOMMENDED

Protegge dall'usura, sempre ad alte temperature. Fornisce anche un'ottima protezione contro la corrosione.

NON DEVE ESSERE UTILIZZATO DOVE VIENE RACCOMANDATO API-GL5



REC85122800



ATF-oil Type Dexron III  
REC1161995

**NEUTRA-SALT**

Ref.	R.O. OEM	VISCOSIDAD VISCOSITY VISCOSITÀ
REC21687793	21687793 41103103	0.95 L
REC21687796	21687796 41103102	3.8 L

Disuelve la sal de los depósitos. Previene el óxido y la corrosión (incluye un inhibidor de corrosión que deja una capa protectora en todas las superficies metálicas).

Dissolves salt and salt deposits. Prevents rust and corrosion (includes a corrosion inhibitor which leaves a protective coating on all metal surfaces).

Scioglie il sale dei depositi. Previene ruggine e corrosione (include un inibitore di corrosione che lascia uno strato protettivo su tutte le superfici metalliche).



REC21687793



REC21687796

**MATERIALES GENÉRICOS PARA REVISIÓN  
GENERIC MATERIALS FOR REVISION  
MATERIALI DI REVISIONE GENERICI**

DESCRIPCIÓN	DESCRIPTION	DESCRIZIONE	REF
IMPRIMACIÓN PARA MOTOR	SPRAY PRIMER	PRIMER PER MOTORI	GS90012
PINTURA MOTOR GRIS (1995)	GREY ENGINE PAINTS (1995)	PITTURE MOTORE GRIGIO (1995)	PS111044
PINTURA GRIS AQUAMATIC	GREY ENGINE PAINTS AQUAMATIC	PITTURE MOTORE GRIGIO AQUAMATIC	GS90034
PINTURA MOTOR ROJO (1972+)	RED ENGINE PAINTS (1972+)	PITTURE MOTORE ROSSO (1972+)	GS90005
PINTURA MOTOR VERDE AGUA (1972+)	GREEN WATER ENGINE PAINTS (1972+)	PITTURE MOTORE VERDE ACQUA (1972+)	GS90007
PINTURA GRIS AQUAMATIC 89	GREY ENGINE PAINTS AQUAMATIC 89	PITTURE MOTORE GRIGIO AQUAMATIC 89	GS90029
PINTURA GRIS METAL SX/DPX	GREY METAL ENGINE PAINTS SX/DPX	PITTURE MOTORE GRIGIO METALLIZZATO SX/DPX	GS90003
BARNIZ TRANSPARENTE PROTECTOR PINTURA EN SPRAY	CLEAR VARNISH, SPRAY PAINT PROTECTOR	VERNICE TRASPARENTE, PROTETTORE DI PITTURA. SPRAY	GS90019
PROTECTOR ÓXIDO MOTOR EN SPRAY	SPRAY ENGINE PROTECTOR FROM RUST	PROTETTORE MOTORE DALL'OSSIDAZIONE. SPRAY	GS90090
PROTECTOR DIeléCTRICO EN SPRAY	SPRAY DIELECTRIC PROTECTOR	PROTETTORE DIELETTRICO. SPRAY	GS90092
BOTE GRASA MARINA 450 g	MARINE GREASE 450 g	GRASSO MARINO 450 g	LUB11404
GRASA DE LITIO	LITHIUM GREASE	GRASSO AL LITIO	LUB11363



# ÍNDICE / TABLE OF CONTENTS / INDICE

REF-->R.O. / OEM

REF.	R.O. /OEM	PAG	REF.	R.O. /OEM	PAG	REF.	R.O. /OEM	PAG
AM603905		404	CEF500178G	21213664	338-345-346-347-474-475	CM832598	832598	457-478
AM603910		404	CEF500380	3555413	345	CM832598A	832598	457-478
AM603915		404	CEF500505FL	876633	448	CM832934	832934	458
AM603920		404	CEF500505K	875848	448	CM838929	838929	458-471-472-474
AM603930		404	CEF500505K	876631	437-448	CM838929A	838929	458
BAOMC-1-3858850P		318	CEF500510K	875826	447	CM851983	876286	415-426-456-478
BAOMC-20-3862603	3851227	326	CEF500510K	876294	447	CM851983A	876286	415-456-478
BAOMC-20-3862603	3856617	326	CEF500510K	897889	447	CM852018	852018	458
BAOMC-20-3862603	3856662	326	CEF500514K	3841481	438-448	CM852018A	852018	458
BAOMC-20-3862603	3857684	326	CEF500514K	3854127	448	CM852019	8520219	458
BAOMC-20-3862603	3857798	326	CEF500514K	22197130	448	CM852835	352835	478
BAOMC-20-3862603	3857810	326	CEF500528	3850426	438-448	CM852835	852835	437-456-478
BAOMC-20-3862603	3863071	318-326	CEF500530	858729	328-449	CM852835A	852835	456-478
BAOMC1-3852347	3852347	323-325	CEF500530	858955	328-449	CM855105	855105	456
BAOMC20-910380	3850799	318-326	CEF500531	860396	449	CM872139	872139	457-478
BAOMC29-910303	3854254	335	CEF500536K	3888916	448-479	CM872139A	872139	457-478
BRA125-1/2x1/2		369	CEF500537K	3594509	447	CM872793	872793	456
BRA125-1/2x3/4		369	CEF500537K	3808898	447	CM872793A	872793	456
BRA125-1/2x3/8		369	CEF500537K		479	CM873395	873395	457
BRA125-1/4x1/2		369	CEF500538K	3588753	448-478	CM873395A	873395	457
BRA125-1x3/4		369	CEF500538K	3808536	448	CM873411	873411	458
BRA125-3/16x1/4		369	CEF500538K	3862168	448	CM873412	873412	458
BRA125-3/4x1/2		369	CEF501001	854932	449-478	CM875812	875812	456
BRA125-3/8x1/2		369	CEF501001	22303438	415-449-478	CM875812A	875812	456
BRA125-3/8x3/8		369	CEF501002	854555	449	CM875821	875821	426-427-457-478
BRA125-5/16x3/8		369	CEF501002	875747	449	CM875821A	875821	426-427-457-478
BRA125-5/8x1/2		369	CEF501002	876632	449-478	CM876638	876638	457-478
BRA125-5/8x3/4		369	CEF501010	3852352	449	CMCMV-18	875815	426-457-478
BRA125-5/8x3/8		369	CEF501011	875822	449	CMCMV-18A	875815	426-457-478
BS2141	841178	405	CEF501011	22303438	449	CMDPHKITA		459-479
BS2142	3854164	405	CM280DPKITA		459-479	CMDPHKITM		459
BS2143	3854186	405	CM280DPKITM		459	CMSXAKITA		459-479
BS5138		405	CM280KITA		459	CMSXAKITM		459
BS5139		405	CM280KITM		459	CMSXKITA		459-479
BS5140		405	CM290DPKITA		459-479	CMSXKITM		459
BS5141		405	CM290DPKITM		459	CMV-15	875810	456-478
BS5142		405	CM290KITA		459-479	CMV-16	875809	456
BS5143		405	CM290KITM		459	CMV-17	875805	426-457
BS5291		404	CM3588745	3588745	458-478-479	CMV-17A	875805	457
BS5292		404	CM3588745A	3588745	458	CHAL90C		396
BS5293		404	CM3588745A	3588770	478	CHAP8Y		396
BS5294		404	CM3588746	3588746	458-478	CHARD16		396
BS5295		404	CM3588746A	3588746	458-478	CHARJ12YC		396
BS5296		404	CM3588746A	3588748	478	CHARL82C		396
BS5297		404	CM3593881	3593981	414-458-478	CHARL82YC		396
BS5298		404	CM3593881A	3593981	458	CHARL86C		396
BS5299		404	CM3841427	3841427	478	CHARN7YC		396
BVA0990730A	854766	468	CM3841427	3888817	439-457-478	CHARN9YC		396
BVA0990740A	854767	468	CM3841427A	3888816	439-457-478	CHARS12PYP		396
BVA0990750A	854768	468	CM3852970	3852970	457	CHARS12YC		396
BVA0990760A	854769	468	CM3852970A	3852970	457	CHARS15LYC		396
BVA0990770A	854770	468	CM3854130	3586461	478	CHARS9YC		396
BVB0990630A	854816	468	CM3854130A	3854130	438-457-478	CHARV15YC4		396-476
BVB0990640A	854817	468	CM3854130A	3586461	478	CHARV9YC		396
BVB0990650A	854818	468	CM3854130A	3854130	438-457	CHAV63C		396
BVB0990660A	854819	468	CM3855411	3855411	428-429-431-457-478	DAY17305	958481	465
BVB0990670A	854820	468	CM3855411A	3855411	428-429-431-457	FEL17000	3853336	274
CARP74021		373	CM3855411A	3863193	478	FEL17010	3854299	275
CEF500100GX	3586494	344-346-347	CM3858399	3858399	459-478	FEL17020	3853380	277
CEF500103T	3854286	345-347	CM3858399A	3858399	459-478	FEL17030	3853380	279
CEF500104	876120	338-345-347-476	CM3861634	3861634	417-457	FEL17040	856575	282
CEF500105T	2170344	345-347	CM3861634A	3861634	417-457	FEL17042	3853511	282
CEF500106GT	3841697	346	CM3861636	3861636	457	FEL17048	3853587	284
CEF500106GT	21951356	346	CM3861636A	3861636	457	FEL17049		284
CEF500106GT		347	CM3883728	3842607	433	FEL17060		276-281
CEF500107T	21213660	345-346-347	CM3883728	3888813	478	FEL17102		274
CEF500114T	3588475	346-347-475	CM3883728A	3888814	432-434-457-478	FEL17115		275
CEF500116GX	3593656	346	CM3883728A	3842607	433	FEL17116		275
CEF500116GX	22222936	346	CM3888305	3888813	432-434-457-478	FEL17120		278-280
CEF500116GX	35993659	344	CM3888305	3888305	456	FEL17124		279
CEF500116GX		347	CM3888305	22651246	478	FEL17125		277-279
CEF500120T	835874	345	CM3888305		415	FEL17140		283
CEF500121GX	21951342	346-347	CM3888305A	3888305	415-456-478	FEL17145		283-285
CEF500124		345	CM40005875	23172849	414	FEL17146		283-285
CEF500135	8777066	346	CM40005875	40005875	414	FEL17160		276
CEF500135	21951362	346	CM40005875	40005875	458	FEL17161		276
CEF500145T	875697	346	CM40005875A	23172849	414	FEL17165		281
CEF500145T	875814	346	CM40005875A	23172856	478	FEL17166		281
CEF500145T	21951364	346	CM40005875A	40005875	414	FEL17200		274
CEF500162G	3887761	346	CM40005875A	40005875	458	FEL17201		283
CEF500162G	21951358	346	CM41100098	41100098	458	FEL17205		283
CEF500162G		347	CM41100276	41100276	458	FEL17207		285
CEF500163G	3830459	346	CM41100276P	41100276	458	FEL17210		275
CEF500170CG	875575	344-345-347	CM823661	823661	458	FEL17211		275
CEF500177GT	3593573	346	CM823661A	823661	458	FEL17212		279
CEF500177GT	21730348	346	CM828140	873413	458	FEL17220		277
CEF500177GT		347				FEL17224		277
						FEL17230		279
						FEL17232		279

REF.	R.O./OEM	PAG	REF.	R.O./OEM	PAG	REF.	R.O./OEM	PAG
FEL17240		282	HGE8870	3854045	325	MAR061	3862198	327
FEL17242		282	HGE8870	3857450	325	MAR061	3863061	320-322-323-324-327
FEL17243		282	HGE8870	3858870	318-325	MAR061		320-322-324
FEL17249		284	HGE8870	3858871	325	MAR289	861289	328-331
FEL17260		276-281	HOT20909	3854466	327	MAR345	859865	329
FEL17261		276-281	HOT20909	3855270	327	MAR345	861574	329
FEL17280		282	HOT20909	3856444	327	MAR345	3589544	329
FEL17281		284	HOT20909	3857402	327	MAR345	21424345	329-331
FEL17304	3853256	274-318	HOT20909	3861842	327	MAR499	3847499	320-325
FEL17310	857177	275	HOT20909	3862198	327	MAR499	3852338	325
FEL17320	856365	278-280	HOT20909	3863061	320-322-323-324-327	MAR499	3857656	325
FEL17340	856616	283	HOT20909-MK		320-322-324	MAR499	3857678	325
FEL17341		283-285	HOT20930	834438	325	MAR501	3847501	322-325
FEL17342	3854095	283-285	HOT20930	855387	317-325	MAR501	3852374	325
FEL17360		277-281	HOT20930-MK		317-320	MAR501	3857723	325
FEL17410	856116	288-319	HOT20931	835804	325	MAR627	3862627	320-322-327
FEL17410	3853412	275-288-320	HOT20931	855926	325	MAR627	3862904	327
FEL17420	856034	278-321	HOT20931	856883	321-325	MAR701	3884701	329
FEL17420	3852468	322	HOT20931-MK		321	MAR701	3583856	329
FEL17420		280	HOT20935	855384	327	MAR870	3854045	325
FEL17440	3852472	284-285-324	HOT20935	856891	321-327	MAR870	3857450	325
FEL17460	3852455	277-281-323	HOT20935-MK		321	MAR870	3858870	318-325
FEL17725		278-280	HOT20986	3847501	322-325	MAR870	3858871	325
FEL17725		278-280	HOT20986	3852374	325	MAR906	861906	329-331
FEL17740		284-285	HOT20986	3857723	325	MAR906	21190094	329
FEL17900	3852693	275	HOT20992-MK		320-322	MAR963	859963	328-331
FEL17903	3856443	275	HOT20992-MK		320-322-324	MP0180-000	10-812509184	400
FEL17920	3854300	276	JAB17018-0001	3593573	346	MP0180-001		400
FEL17921	3854942	276	JAB17018-0001	21730348	346	MP39200	856659	401
FEL17930	835096	279-280	JAB17018-0001		341-347-475	MP425024	3855805	330
FEL17931	3852687	278-280	JAB17937-0001-P	3588475	346-341-347	MP425036	3855806	330
FEL17935	856626	284-285	JAB17938-0001-P	3830459	342-346	MP425113	3854100	330
FEL17937	3853513	284-285	JAB18777-0001-P		347	MP426422	3854346	376
FEL17945		277-282	JOH09-1026B	3593656	346	MP426422	3858331	376
FEL17946		277-282	JOH09-1026B	22222936	346	MP426422	3859066	376
FEL17971	3852655	276	JOH09-1026B	35993659	344	MP426422	21610334	376
FEL17980	855729	278-280	JOH09-1026B		347-474-475	MP426434	3850288	376
FEL17981		278-280	JOH09-1027B	21213660	345-346-337-338-339-340-347-347-471-474-475-477	MP426434	3858333	376
FEL17982	3856138	278-280	JOH09-1028B	3841697	346	MP426574	3855279	376
FEL17983		278-280	JOH09-1028B	21951356	346	MP426766	3855957	376
FEL17985	856889	284	JOH09-1028B		339-347-471-472-473-475	NGKBP6ES		396-475
FEL17986	3853510	284-285	JOH09-1028B		345-347-472	NGKBP7ES		396-475
FEL17995		277	JOH09-1028B		344-345-347-471-475	NGKBP7HS		396-475
FEL17996		281	JOH09-1029B	2170344	346	NGKBP6EFS		396-397-477
FEL17997		277	JOH09-801B	875575	344	NGKBP6EIX		396
FEL17998		282	JOH09-806B	875807	344	NGKBP6ES		396
GDY15295	978457	464	JOH09-806B	876689	344	NGKBP6FS		396-397
GDY15335	966958	465-473	JOH09-806B	3586494	344-346-347-471-474	NGKBP7EIX		396
GDY15356	3850268	464	JOH09-808B	21951342	346-347-471-474	NGKBR6FIX		396-397-476
GDY15382	3852348	464	JOH09-812B		340-345-475-477	NGKBR6FS		396-397-475-476
GDY15386	966870	465-473-474	JOH09-814B	875697	346	NGKTR5		397
GDY15545	966929	464-471	JOH09-814B	875814	346	NGKTR55		396-397
GDY17291	967158	463-475	JOH09-814B	21951364	346	NGKTR55IX		396-397
GDY17291	9671587	465	JOH09-814B	8777066	346	NGKTR5IX		397
GE15210		375	JOH09-819B	21951362	346	NGKTR6IX		396-397
GE21204		375	JOH09-819B		472-473-474	NGKUR4		397
GE22207		375	JOH09-821B	3887761	346	NGKUR4IX		397
GE22254		375	JOH09-821B	21951358	346	NGKUR5		396
GS30430		370	JOH09-821B		347-472-475	NGKUR6		396-475-476
GS30431		370	JOH10-22335-3	842275	340	NGKUR6IX		396-397-476-477
GS30432		370	JOH10-24061-3	842843	339	NGKXR5		396
GS30433		370	JOH10-24130-3	838522	339	NGKYR5		396-475
GS31065		360	JOH10-24130-3	844971	339	NGKYR5IX		396
GS31066		360	JOH10-24268-4	858150	339	OSC5805-MK		321
GS31067		360	JOH10-24277-3	858469	339	PH140-0004	841066	398
GS31155		360-369	JOH10-24707-01	840557	338	PH140-0004	3854190	398
GS31156		360-369	JOH10-24707-01	861009	338	PH140-0004-CCW		405
GS31157		360	JOH10-32058-1	831178	337	PH140-0013	834893	399
GS31166		360-369	JOH10-32621-2	828026	337	PH140-0013	835121	399
GS38103		451	JOH10-32621-2	855517	337	PH140-0013	855326	399
GS38104		451	JOH10-32621-2	855578	337	PH140-0013		405
GS38320	3852604	318-320-322-323-324	JOH10-35098-3	829895	338	PH140-0015	3850525	399
GS38322	3863443	320-322-323-324	JOH10-35157-1	807368	339	PH140-0015	3853982	399
HGE1502	22948847	329	JOH10-35157-1	833415	339	PH140-0017-D	3660566	399
HGE1502	22671214	329	JOH10-35157-1	833883	339	PH140-0017-D	3857747	399
HGE1502	21700014	329	JOH10-35157-1	840076	339	PH140-0017-D	3885317	399
HGE1640	3884701	329	JOH10-35157-1	858065	339	PH140-0017-D		405
HGE1640	3583856	329	JOH10-35157-3	807368	339	PH140-0017-HT	3860764	399
HGE35908		319	JOH10-35157-3	833415	339	PH140-0020	3854750	400
HGE4532	824532	288-317-326	JOH10-35157-3	833522	339	PH140-0020	3856003	400
HGE5261	843217	328	JOH10-35157-3	833883	339	PH140-0020-D	3862308	400-405
HGE5261	845261	328-331	LENS3213		361	PH140-0022	841377	400
HGE5387	834438	325	LENS3227		361	PH140-0022-CCW	3862985	400
HGE5387	855387	317-325	LENS3240		361	PH140-0022-CCW	21129980	400
HGE5528	845528	328-331	LUB11578U12		406	PH140-0023	859593	398
HGE5599	825598	326	MAR061	3854466	327	PH140-0023	872241	398
HGE5599	825599	317-326	MAR061	3855270	327	PH150-0007	188486	398
HGE6894	841676	325	MAR061	3856444	327	PH150-0007	3581774	398
HGE6894	856137	325	MAR061	3857402	327	PH150-0007	859252	398
HGE6894	856894	319-325	MAR061	3861842	327	PH150-0007-OE	188486	398
HGE7037	855380	326				PH150-0007-OE	3581774	398
HGE7037	856895	326						
HGE7037	857037	319-326						

REF.	R.O./OEM	PAG	REF.	R.O./OEM	PAG	REF.	R.O./OEM	PAG
PH150-0007-OE	8599252	398	RACR24S		364	REC15-405	3888324	392-397
PH150-0007-OE		405	RACR24T		364	REC15-601	3888325	392-397
PH200-T007	3858071	406	RACR25P		364	REC15-604	3857166	397
PH200-T012	3861575	406	RACR25S		364	REC15-606	3888327	393-397
PH200-T017	854346	406	RACR25T		364	REC15-801	3857166	397
PH200-T017	3586765	406	RACR26P		364	REC15-804	3888326	392-397
PH200-T017	3857265	406	RACR26S		364	REC15-806	3857166	397
PH200-T017	3861027	406	RACR26T		364	REC15-808	3861295	397
PH200-T017		406	RACR60P		364	REC15-815	3888328	393-397
PH200-T023	3853945	406	RACR60S		364	REC1504952	1504952	403
PH200-T027	852928	406	RACR60T		364	REC150MINORKIT		350
PH200-T027	3586765	406	RACR90P		364	REC1542052	1542052	297
PH200-T028	850834	406	RACR90S		364	REC1542123	1542123	298
PH200-T064-1B	854531	407	RACR90T		364	REC1542123	1542177	298
PH200-WH01		406	RACRK19492UL		370	REC1542187	1542187	355
PH300-0008-D	873770	401	RACRK20726		370	REC1542318	1542318	303
PH300-0010	3854809	402	RACS3213		361	REC1542389	1542389	314
PH300-0010	3860769	402	RACS3214		361	REC1542472	1542472	314
PH300-0014	3860171	402	RACS3220UL		361	REC1544119	1544119	296
PH300-0014	83857561	402	RACS3227		361	REC1545198	1545198	314-315
PH300-0015	3857813	402	RACS3228UL	857633	361	REC155MINORKIT		350
PH300-0017	3860798	402	RACS3240		361	REC16-70236	3853373	318
PH300-0017	3862612	402	REC0307239	3852071	355	REC1674083	463828	343
PH300-0027-OE	873770	403	REC062MINORKIT		349	REC1674083	1357775	343
PH300-0036	3862612	402	REC10-37612	3853155	323	REC1674083	1674083	343
PH300-0037	3862613	402	REC10-37612	3855983	323-324	REC1674083	1674084	343
PH300-0037	3862665	402	REC10-861788	10-861788	399-400	REC1674083	3850064	343
PH300-0037	3884950	402	REC10615K	835874	345	REC17253	17253	435-436
PH360-0003	876037	404	REC1066823		463	REC17276	17276	419-435-436-479
PH365-0003		404	REC11043	11043	419	REC17937-0001	3588475	346
PH365-0006		400	REC11044	11044	427-429-431	REC18-5295		394
PH375-0001		405	REC11065	11065	419	REC18-8114		377
PH375-0004		399-400-405	REC11072	11072	426-427	REC18-8115		377
PH375-0005		399	REC11096	11096	419	REC181620	181620	435
PH375-0008		399-400-405	REC1140639		365-370	REC181804	181804	419
PH375-0009	3854194	398-405	REC1161995	1161995	481	REC183247	183247	420-421-423-424-425
PH375-0013	859618	405	REC120		365	REC183247	3850853	417
PH375-0027	3853839	405	REC12100		312	REC183272	183272	417-427-429-431-432-434
PH375-0028	852565	405	REC121152		295	REC183374	183374	426-427
PH600-0002	856609	333	REC121153		295	REC183390	183390	426
PH600-0002	3854118	333	REC121154		295	REC183390	184642	419
PH600-0002	3855991	333-335	REC1218630	418423	314	REC183391	183391	435
PH600-0003	3861341	333-335	REC1218630	1218630	316	REC183765	183765	419
PH600-0004	3854017	332	REC125017	125017	425-435-436-444-479	REC183859	183859	417-427-429-431-432-434
PH600-0004	3858340	332-335	REC12532	841244	389	REC183859	183859	342
PH600-0004		333	REC126870	3852020	428-442	REC183861	183861	419-427-429-431-432-434
PH600-0005	3853850	332-333-335	REC1276425	1276425	303	REC184654	184654	427-429-431
PH600-0006	3853796	333-335	REC127695-35150	423135	367	REC184682	184682	417-427-429-431-432-434
RAC1/2F-1/2M		370	REC127695-35150	4785974	367	REC184683	184683	417-427-429-431-432-434
RAC1/2x16		369	REC127695-35150		472-473	REC184765	184765	417-427-429-431-432
RAC1/2X18		369	REC12784	12784	419	REC184778	184778	419
RAC1/2X20		369	REC13-35048	3852002	320-322-323-324	REC18777-0001		347
RAC1000MA30		363	REC1302		375	REC19029		445
RAC110A		364	REC1306169	1306169	388	REC19035		443
RAC120AS		364	REC1306341	1306341	316	REC19037	876266 + 876268	443
RAC120R-RAC-01		361	REC1306630	1306630	313-314	REC19088		408
RAC1606B		370	REC1317761	1317761	316	REC191844	191844	437
RAC2010PM-OR	3581760	363	REC1317761	1326239	316	REC192212	192212	316
RAC2010SM-OR	1147147	363	REC1317792	1317792	314	REC192212	463904	316
RAC2010TM-OR	861014	363	REC1317793	1317793	314	REC192212	463904	316
RAC2020PM-OR	889419	363	REC1324492	1324492	403	REC19876		411
RAC2020SM-OR	889425	363	REC1324750	1324750	384	REC20450736	20450736	355
RAC2020TM-OR	3838854	363	REC1336385	1336385	385	REC20513285	20513285	315
RAC2040PM-OR	889419	363	REC1336763	1336763	316	REC20739057	20739057	315
RAC2040SM-OR	889421	363	REC13554-0001	13554-0001	345	REC207MINORKIT		349
RAC2040TM-OR	3838852	363	REC1378645	463412	286	REC21-20553	3852058	320-322-323-324
RAC230R2		364	REC1378645	31378645	286	REC21124849	21124849	385
RAC245R2		364	REC1378646	1326785	286	REC21132189	3584126	372
RAC3/8F-3/8M		370	REC1378646	1332644	286	REC21132189	21132189	372
RAC3/8X10		369	REC1378646	1378646	286	REC21132392		462-477
RAC3/8X12		369	REC1378646	1378646	286	REC21134777	833323	371
RAC3/8X14		369	REC1378853	1378853	288	REC21134777	21134777	371
RAC320R-INOX-01		361	REC1378854	1378854	288	REC21139810	21139810	365
RAC320R-RAC-01		361	REC1378864	418262	289	REC21141637	3593656	340
RAC320R-RAC-02		361	REC1378864	463587	289	REC21141637	3884694	340
RAC460R2		364	REC1378864	1378864	289	REC21141637	21141637	340
RAC490R2		364	REC1378870	1336753	288	REC21160912	21160912	464
RAC500MA30		363	REC1378870	1378870	288	REC21165389	3581868	292
RAC75/1000MA30		363	REC1378879	463225	288	REC21165389	21165389	292
RAC75/500MAX		363	REC1378879	1266796	288	REC21165390	3581869	292
RAC900MA30		363	REC1378879	1378879	288-317	REC21165390	21165390	292
RAC913-O10-H10		369	REC1378909	1378909	287	REC21171277	3881586	369
RAC913-O10-H8		369	REC1378911	418870	288	REC21171277	3886591	369
RAC913-O8-H6		369	REC1378911	1378911	288	REC21171277	3889484	369
RAC913-O8-H8		369	REC1378913	461092	288-319	REC21171277	21171277	369
RACPFF5510	855686	360	REC1378913	1378913	288	REC21192875	1665251	368
RACR11T		364	REC1378914	461113	289	REC21192875	20532237	368
RACR12P		364	REC1378914	1378914	289	REC21192875	21192875	368
RACR12S		364	REC1396-4656	3854106	378-379	REC21192973	3840843	291
RACR12T		364	REC1396-5238	3854107	376-378-379			
RACR20P		364	REC1397-3327		377-378			
RACR20S		364	REC13980	3850802	318			
RACR20T		364	REC1463-9382	835998	395			
RACR24P		364	REC15-404	875571	397			

REF.	R.O./OEM	PAG	REF.	R.O./OEM	PAG	REF.	R.O./OEM	PAG
REC21192973	21192973	291	REC21484383	3841840	411	REC21924270	21924270	468
REC21192974	3889517	291	REC21484383	21484383	411-439	REC21945911	3884410	409
REC21192974	21192974	291	REC21492771	466987	366	REC21945911	21945911	409
REC21196919	3885441	368	REC21492771	829993	366	REC22-428611	3852135	320-322-323-324
REC21196919	21196919	368	REC21492771	3825133	366	REC22-67892A05	3854539	415
REC21212799	3812519	338	REC21492771	21492771	366	REC22-67892A05	3854539	423-424-428-432-433
REC21212799	21212799	338	REC21492771	471-472-473-474	366	REC22-73379	3850740	320-322-323-324
REC21212799		342	REC21533394	854256	379	REC22005		317
REC21212800	3812518	338	REC21533394	21533394	379	REC22008		351
REC21212800	21212800	338	REC21533394		376-378	REC22009		343
REC21213660	21213660	338-344-345-346-347	REC21585053	21585053	460	REC22011	876224	351
REC21213664	21213664	337-338-345-347	REC21622232	21622232	391-393	REC22012		351
REC21214599	3812693	337	REC21632901	21632901	368	REC22013		333
REC21214599	3857202	337	REC21632901	22030852	368	REC22014		333
REC21214599	3862482	337	REC21632901		475	REC22015		358
REC21214599	21214599	337	REC21646645	3582358	368	REC22016		344
REC21214599		342	REC21646645	21646645	368	REC22017		351
REC21214601	3812695	338	REC21646645	21782391	368	REC22019		351
REC21214601	3860795	338	REC21646645	471-472-474	368	REC22021		352
REC21214601	3862484	338	REC21655254	3587046	336	REC22022		359
REC21214601	21214601	338	REC21655254	3594159	336	REC22024		351
REC21214601		342	REC21655254	3594161	336	REC22024631	3850357	387
REC21219723	21219723	341-349	REC21655254	3809093	336	REC22024631	22024631	387
REC21250645	3808796	384	REC21655254	3809097	336	REC22025		352
REC21250645	21250645	384	REC21655254	21610728	336	REC22032		357
REC21280913	3809465	461	REC21655254	21655254	336	REC22033		357
REC21280913	3848896	461	REC21687793	21687793	336-481	REC22034	3883844	299
REC21280913	3883786	461	REC21687793	41103103	336-481	REC22037		336-351
REC21280913	21172053	461	REC21687796	21687796	336-481	REC22038		333
REC21280913	21280913	461	REC21687796	41103102	336-481	REC22039		333
REC21302969	21302969	398	REC21702999	3583654	369	REC22040		344
REC21310068	3183211	315	REC21702999	3818541	369	REC22042		343
REC21310068	21310068	315	REC21702999	21702999	369	REC22045		319
REC21323043	3583555	398	REC21702999		475	REC22047		343
REC21323043	3801351	398	REC21707132	471392	368	REC22051		351
REC21323043	3803929	398	REC21707132	477556	368	REC22053		343
REC21323043	21323043	398	REC21707132	21707132	368	REC22054		344
REC21363429	21363429	480	REC21707134	466634	367	REC22055		440
REC21363430	21363430	480	REC21707134	21707134	367	REC22057		440
REC21368879	21368879	369	REC21707134	473-474	367	REC22059		440
REC21371111	3588433	295	REC21711728	21711728	307	REC22060		440
REC21371111	21371111	295	REC21721548	21721548	409	REC22061		351
REC21371111		292	REC21721548	3809559	409	REC22063494	22063494	341-349
REC21371112	3588432	294	REC21721550	21721550	409	REC22070		359
REC21371112	21371112	294	REC21721550	3809560	409	REC22072		343
REC21379102	21106041	340	REC21730344	2170344	345	REC22073		348
REC21379102	21379102	340	REC21730344	8777066	346	REC22074		440
REC21379288	21141341	368	REC21730344	21951362	346	REC22075		440
REC21379288	21379288	368	REC21730344	341-344-347-349	368	REC22077		356
REC21379288		475	REC21760		291-293	REC22085		444
REC21380886	3819485	341	REC21761		291-293	REC22086		426-444
REC21380886	3836314	341	REC21762		291-294	REC22087		427-444
REC21380886	21380886	341	REC21763		291-294	REC22089		344
REC21380886		349	REC21764		291-294	REC22097		445
REC21380890	3584063	341	REC21765		291-294	REC22103		358
REC21380890	3589907	341	REC21766		300-302	REC22104		359
REC21380890	21380890	341	REC21840806	3857470	407	REC22105		357
REC21380890		349	REC21840806	3888301	407	REC22106		357
REC21380890		349	REC21840806	21840806	407	REC22107		357
REC21389074	872026	449	REC21840806		408	REC22108		357
REC21389074	877362	449	REC21849843	21849843	299	REC22109		358
REC21389074	3840050	449	REC21880386	860631	336	REC22110		358
REC21389074	3856597	449	REC21880386	21641712	336	REC22111		358
REC21389074	21112450	449	REC21880386	21880386	336	REC22113		352
REC21389074	21389074	415-449-478	REC21913334	21687472	367	REC22114		352
REC21400091	873765	404	REC21913334	21913334	367	REC22115		352
REC21400091	11305263	404	REC21921545	21921545	304	REC22116		352
REC21400091	21400091	404	REC21924262	854765	468	REC22119		298
REC21405493	21405493	465	REC21924262	854814	468	REC22120		298
REC21407028		463	REC21924262	854814	468	REC22120-0001	876120	345-475-476
REC21412639	21412639	355	REC21924262	2194262	468	REC22121		298
REC21419374	21419374	341-349	REC21924262	21924262	468	REC22121309	3887960	407
REC21419374	21419374	341-349	REC21924263	854766	468	REC22121309	21840807	407
REC21423488	874501	399	REC21924263	854815	468	REC22121309	22121309	407
REC21423488	3588491	399	REC21924263	21924263	468	REC22122		408
REC21423488	3801296	399	REC21924264	854767	468	REC22123		357
REC21423488	3803648	399	REC21924264	854816	468	REC22124		357
REC21423488	3803855	399	REC21924264	21924264	468	REC22125		334
REC21423488	3803938	399	REC21924265	854768	468	REC22126		334
REC21423488	3804296	399	REC21924265	854817	468	REC22127		359
REC21423488	21423488	399	REC21924265	21924265	468	REC22128		359
REC21426987	20513343	386	REC21924266	854769	468	REC22134		299
REC21426987	21426987	386	REC21924266	854818	468	REC22143		359
REC21436799	21436799	395	REC21924266	21924266	468	REC22145		319
REC21450768	3583915	329	REC21924267	854770	468	REC22148		357
REC21450768	3819016	329	REC21924267	854819	468	REC22149		359
REC21450768	21450768	329-331	REC21924267	21924267	468	REC22151		444-445
REC21450768		331	REC21924268	854771	468	REC22152		359
REC21457172	3582986	336	REC21924268	854820	468	REC22153		359
REC21457172	3583338	336	REC21924268	21924268	468	REC22154		358
REC21457172	3809070	336	REC21924269	854772	468	REC22155		356
REC21457172	3809071	336	REC21924269	854821	468	REC22156		356
REC21457172	3889148	336	REC21924270	21924269	468			
REC21457172	21457172	336		854773	468			

REF	R.O./OEM	PAG	REF	R.O./OEM	PAG	REF	R.O./OEM	PAG
REC22161		440	REC23019		446	REC275342	275342	305
REC22163		440	REC23020	3888822	432-445	REC275344	275344	305
REC22167		344	REC23022	3888821	433-445	REC275346	275346	305
REC22169		408	REC23024		417-446	REC275350	275350	307
REC22170		412	REC23025		417-445	REC275369	275369	306
REC22171		412	REC23027		443	REC275370	275370	306
REC22171036	3582692	461	REC23033		444	REC275751	275595	304
REC22171036	3588305	461	REC23034		446	REC275751	275751	304
REC22171036	3847481	461	REC23035		348	REC275751	875651	304
REC22171036	3883784	461	REC23038		348	REC288MINORKIT		349
REC22171036	21786692	461	REC23040		348	REC3-21ALU		468
REC22171036	22171036	461	REC23048		359	REC30-879194A01	21752712	438
REC22172		408	REC23059414	23059414	333	REC300-00879	3852217	395
REC22185019	876527	305	REC23120		442	REC30650525	30650525	292
REC22185019	877071	305	REC23170		435-442	REC30677767	30677767	334-335
REC22185019	22185019	305	REC238258	238258	388	REC30713459	30713459	296
REC22185027	876851	305	REC241652	241652	388	REC30729340	30729340	298
REC22185027	3581714	305	REC241669	241669	388	REC30731261	30731261	292
REC22185027	3817034	305	REC243653	243653	388	REC30731262	30731262	292
REC22185027	22185027	305	REC243658	243658	388	REC30731263	30731263	292
REC22187385	3889954	407	REC243797	243797	388	REC30731264	30731264	292
REC22187385	22187385	407	REC243799	243799	388	REC30731809	30731809	464
REC22187385		408	REC243903	243903	388	REC30788490	30788490	368
REC22187386	3779955	407	REC24942		360	REC309731	3852537	438
REC22187386	22187386	407	REC24950		360	REC31-66668A1	3854249	415-417-428- 429-431-432- 433-434
REC22187386		408	REC24952		360	REC31-86748A1	183512	431
REC22188	3850984	443	REC25-30613	997368	424	REC31-86748A1	3854250	428-429-432- 433-434
REC22189	3850984	443	REC25-30613	3852565	417-423	REC31-86748A1	6854250	417
REC22256171	3861068	447	REC25-30613		479	REC31216308	31216308	387
REC22256171	22256171	414-447	REC25-33145	3852044	438	REC31251252	30637961	461
REC22283751	22283751	464	REC25000		360	REC31251252	30757056	461
REC22314183	828726	411	REC25010		360	REC31251252	31251252	461
REC22314183	873531	411	REC25020		360	REC31251252		463
REC22314183	22314183	411-437	REC25030		360	REC31339213	31339213	303
REC22336734	3852329	417	REC26-34217	3854956	313	REC31359568	30731772	460
REC22336734	22336734	419-423-424- 435-436	REC26-75988	3853521	313	REC31359568	31258305	460
REC22336734		421	REC26900		394	REC31359568	31359568	460
REC22352491	22352491	464	REC26901		394	REC31419556	30659131	402
REC22377272	3888460	366	REC26902		394	REC31419556	30667118	402
REC22377272	22377272	366	REC26903		394	REC31419556	31419556	402
REC22389354	876261	305	REC26904		394	REC31430317	30777600	296
REC22389354	876784	305	REC2696		377	REC31430317	31430317	296
REC22389354	876819	305	REC27-142471		276	REC3183211	3183211	315
REC22389354	876834	305	REC27-33395	856034	321	REC3183211	21310068	315
REC22389354	22389354	305	REC27-33395	3852468	322	REC3287677	3287677	395
REC22393048	3580305	313-314	REC27-33918	835417	355	REC3302-9031		377-378
REC22393048	3580306	313	REC27-33918	3852111	335-355	REC331188	3852169	438
REC22393048	22393048	313-314	REC27-33956	3853342	333-335	REC332583	3852523	438
REC22430456	22430456	434	REC27-34897	3852477	333-335	REC35-06003	835440	362
REC22452005	21745119	412	REC27-41609	27-41609	377	REC35-06003	3852030	362
REC22452005	22452005	412	REC27-46820	3852472	324	REC35-06003	3852412	362
REC22479638	22479638	480	REC27-49110	3853361	333-335	REC35-06003		475-476-477
REC22479642	22479642	480	REC27-56880	3852824	333-335	REC35-06004	841750	362-476
REC22479648	22479648	414-480	REC27-60715	27-60715	377	REC35-06007	835779	362
REC22479650	22479650	480	REC27-65577	27-65577	377	REC35-53336	835576	362
REC22527820	22527820	315	REC27-70142	27-70142	377	REC35-802893Q		360
REC22574246	22574246	480	REC27-803192A2		333	REC35-802893Q01		360
REC22582994	3586857	307	REC27-807473A1	3857662	278-280	REC35-8M0046752		371
REC22582994	22582994	307	REC27-8079821	841031	377	REC3514432	3514432	313
REC22612828	22612828	434	REC27-8146801	3852096	335-355	REC3517857	418432	362-367
REC22612828	22612828	445	REC27-815528	3853256	318	REC3517857	430143	362-367
REC22637542	846762	404	REC27-99757	856116	319	REC3517857	1266286	362-367
REC22637542	860339	404	REC27-99757	3853412	320	REC3517857	3517857	362-367
REC22637542	873740	404	REC270136	270136	310	REC3517857		471-475
REC22637542	22637542	404	REC270137	270137	310	REC3517893	3517860	313-314
REC22663814	21146097	412	REC270906	270906	307	REC3545696	3545696	384
REC22663814	21505553	412	REC270907	270907	307	REC3580026	3580026	303
REC22774756	3582694	461	REC271051	271051	310	REC3580100	3580100	372
REC22774756	3583665	461	REC271052	271052	310	REC3580227	3580227	299
REC22774756	21344508	461	REC271054	271054	310	REC3580309	3580309	291
REC22774756	22774756	461	REC271063	271063	310	REC3580509	3580509	369-474
REC22774756		463	REC271064	271064	310	REC3580514	3580514	355
REC22898644	22898644	470	REC271066	271066	310	REC3580586	3580586	303
REC22898645	22898645	470	REC271067	271067	310	REC3580835	3580835	464
REC22898646	22898646	470	REC271214	271214	307	REC3581078		365-471-475-476
REC22898647	22898647	470	REC271215	271215	307	REC3581528	838695	380
REC22905150	3886848	342	REC271217	271217	307	REC3581528	860916	380
REC22905150	22905150	342	REC271218	271218	307	REC3581528	3581528	380
REC22905150		350	REC271237	271237	307	REC3581528	3802082	380
REC22905155	3589104	342	REC271975	271975	332-335	REC3581536	3581536	375
REC22905155	22905155	342	REC271975	1275148	332	REC3581621	861474	366
REC22905155		350	REC271975	3547560	332	REC3581621	861475	366
REC22915955	22915955	304	REC272002	272002	304	REC3581621	3581621	366
REC22954700	22954700	465	REC272004	272004	304	REC3581621	21549544	366
REC23008		444	REC272040	272040	304	REC3581621		471
REC23009		443	REC272043	272043	304	REC3581696	3581696	375
REC23010		419-446	REC272043	272043	304	REC3581889	3581889	315
REC23011		356	REC272059	272059	304	REC3582310	860320	372
REC23012		356	REC275331	275331	306	REC3582310	1542170	372
REC23013		356	REC275334	275334	305	REC3582310	3582310	372
REC23014		356	REC275336	275336	305	REC3582324	3582324	460-463
REC23015		356	REC275337	275337	306	REC3582432	838628	291
REC23018		419-444	REC275338	275338	306			
			REC275340	275340	305			
			REC275341	275341	305			

REF.	R.O./OEM	PAG	REF.	R.O./OEM	PAG	REF.	R.O./OEM	PAG
REC3582432	858993	291	REC3588916	874109	384	REC3827069	21549542	367
REC3582432	3582432	291	REC3588916	3588916	384	REC3827069		472-473
REC3582435	876103	294	REC3589322	3589322	292-293	REC3827273	3827273	465
REC3582435	876121	294	REC3589522	3589522	423	REC3827444	874385	398
REC3582435	3582434	294	REC3589524	3589524	423	REC3827444	3827444	398
REC3582435	3582435	294	REC3593573	3593573	346	REC3829311	846354	339
REC3582435		291	REC3593573	21730348	346	REC3829311	3829311	339
REC3582500	859844	372	REC3593573		341-347	REC3829313	845189	340
REC3582500	3582458	372	REC3593654	3580064	340	REC3829313	866396	340
REC3582500	3582500	372	REC3593654	3580900	340	REC3829313	3829312	340
REC3582561	419653	314	REC3593654	3580944	340	REC3829313	3829313	340
REC3582561	3582561	315	REC3593654	3593654	340	REC3831236	3831236	367
REC3582563	876108	299	REC3593655	3580222	340	REC3831236	20821230	367
REC3582563	876312	299	REC3593655	3580223	340	REC3831236	21640514	367
REC3582563	3582563	299	REC3593655	3580910	340	REC3831424	3831424	354-471-472
REC3582563		380-381	REC3593655	3580920	340	REC3831424		354-471-472-473-474
REC3582595	876398	298	REC3593655	3580945	340	REC3831426	824200	353
REC3582595	3582595	298	REC3593655	3593655	340	REC3831426	875788	353
REC3582595		380	REC3593659	3593656	346	REC3831426	3831426	353-354
REC3582596	875633	294	REC3593659	22222936	346	REC3831426		471-472-477
REC3582596	875662	294	REC3593659	35993659	344	REC3837935	863437	340
REC3582596	876395	294	REC3593659		340-343-347-348	REC3837935	876809	340
REC3582596	3582596	294	REC3593663	3593663	415-446	REC3837935	3825493	340
REC3582596		292	REC3593951	3593951	413	REC3837935	3837935	340
REC3582597	875031	294	REC3593951	3593951	413	REC3838207	865295	342
REC3582597	876453	294	REC3594989	3594989	411	REC3838207	3838207	342
REC3582597	3582597	294	REC3594989	3854842	411	REC3838207		349
REC3582597		291	REC3594989	3861837	411	REC3838288		341-349
REC3582606	419652	314	REC3594989	3863129	411	REC3838288	3838288	354-472-473
REC3582606	3582606	315	REC374MINORKIT		349	REC3839110	3839110	365
REC3582608	1378960	314	REC376MINORKIT		349	REC3840335	3588378	365
REC3582608	3582608	315	REC3801138	3801138	382	REC3840335	3840335	365
REC3582609	463371	314	REC3801173	3801173	382	REC3840335	21624740	365
REC3582609	3582609	315	REC3801270	3801270	381	REC3840335		471-472
REC3582639	3582639	358	REC3801270	3802145	381	REC3840525	3589316	367
REC3582725	3582725	297	REC3801271	3801271	381	REC3840525	3840525	367
REC3582732	3582732	368	REC3801271	3802167	381	REC3840525		474
REC3582732	22030848	368	REC3801387	3801387	381	REC3840761	3840761	439
REC3582732		475	REC3801404	3801404	334-335	REC3840816	3840816	355-474-475
REC3582748	3582748	303	REC3801404	3801636	334	REC3840842	3840842	291
REC3582887	3582887	415	REC3801404	30751022	334	REC3840859	3840859	299
REC3582888	3582888	415	REC3801404	31293668	334	REC3840888	3803904	398
REC3583073	3583073	375	REC3801404		334	REC3840888	3840888	398
REC3583089	3583089	340	REC3802092	861407	381	REC3841011	3841011	439
REC3583115	860629	339	REC3802092	3581150	381	REC3841013	3841013	439
REC3583115	860827	339	REC3802092	3802092	381	REC3841481	3841481	438-448
REC3583115	3581558	339	REC3802105	3802105	381	REC3841481	3854127	448
REC3583115	3583115	339	REC3802105	3802112	381	REC3841481	22197130	448-478
REC3583322	3583322	415	REC3802125	3583006	380	REC3841481		479
REC3583336	3583336	297	REC3802125	3802125	380	REC3841697	3841697	346
REC3583443	3583443	366	REC3802149	3802149	382	REC3841697	21951356	346
REC3583443	21718912	366	REC3802150	3802150	382	REC3841697		339-340-341-344-347-348
REC3583443		475	REC3802151	3802151	382	REC3842853	3842853	320-322-328
REC3583546	3583546	297	REC3802152	3802152	382	REC3843100	3587927	385
REC3583700	3583700	303	REC3808228	3808228	438-439	REC3843100	3843100	385
REC3583729	3583729	465-475	REC3808602	3808602	290	REC3843100	3884352	385
REC3583780	3583780	355	REC3808616	3808616	366-384	REC3843136	3843136	419
REC3583786	858992	292	REC3808797	3808797	384	REC3843751	3843751	383
REC3583786	876853	292	REC3808898	3594509	447-478	REC3843751	3857696	383
REC3583786	3580742	292	REC3808898	3808898	419-447	REC3847482	3847482	461
REC3583786	3582433	292	REC3809167	840270	290	REC3847644	3847644	362-477
REC3583786	3583786	292	REC3809167	859136	290	REC3848965	3801204	399
REC3583787	876104	295	REC3809167	859136	290	REC3848965	3848965	399
REC3583787	876530	295	REC3809167	860749	290	REC3848965	30782228	399
REC3583787	3582436	295	REC3809167	3809167	290	REC3849006	3849006	419
REC3583787	3583787	295	REC3809445	3809445	481	REC3850360	3850360	335-353
REC3583787		292	REC3809647	3809647	290	REC3850396	3850396	387
REC3583788	3582437	295	REC3809657	3809657	297	REC3850397	3850397	383
REC3583788	3583788	295	REC3809721	3809721	366	REC3850426	3850426	438-448-478-479
REC3583788		292	REC3809721	21140344	366	REC3850495	3850495	318
REC3583840	3583840	336	REC3812109	3812109	291	REC3850559	3850559	363
REC3583840	21219693	336	REC3812131	3812131	297	REC3850594	3850594	422-446
REC3584062	3584062	341-349	REC3812199	3812199	291	REC3850812	3850812	423-424
REC3584127	3584127	405	REC3812240	3812240	337-338-342	REC3850814	3850814	423
REC3584145	3584145	369	REC3812357	3812357	414	REC3850852	3850852	414-417-420-421-423-424-425
REC3584167	3584167	448	REC3817033	3817033	307	REC3850861	3850861	360
REC3584168	3584168	448	REC3817328	3817328	372	REC3850861	3857325	360
REC3584202	3580482	291	REC3817687	3817687	337-342	REC3850861	3857927	360
REC3584202	3584202	291	REC3817688	3817688	338-342	REC3850861	3858736	360
REC3586494	3586494	343-344-346-347	REC3817861	3586722	305	REC3850942	3850942	428
REC3586496	21951342	338-339-346-347-348	REC3817861	3817861	305	REC3852045	3852045	423-424-425-439-479
REC3586960	3586960	303	REC3818912	3818912	334	REC3852056	3852056	428-442-479
REC3587071	3587071	401	REC3819662	3803903	402	REC3852106	966906	464
REC3587079	3587079	406	REC3819662	3819662	402	REC3852106	966916	464
REC3587079	3857079	406	REC3819905	852939	404	REC3852106	3852106	464
REC3587079	3857489	406	REC3819905	853502	404	REC3852106	3852106	464
REC3587079	3858069	406	REC3819905	856355	404	REC3852106	3852336	464
REC3587079	3860879	406	REC3819905	3819905	404	REC3852106		464-471
REC3587079		406	REC38201	38201	322	REC3852142	3852142	318
REC3587508	828023	332	REC38201	21114522	320-324	REC3852165	3852165	410
REC3587508	3587508	332-335	REC3825038	3825038	369-472	REC3852215	3852215	384
REC3587597	3587597	353-477	REC3827069	829161	363-367	REC3852272	3852272	417-423-424
REC3588434	3588434	301	REC3827069	829390	363-367	REC3852279	3852279	423
			REC3827069	3827069	363-367			



REF.	R.O./OEM	PAG	REF.	R.O./OEM	PAG	REF.	R.O./OEM	PAG
REC3852295	3852295	417-423-424-425	REC3855275	3855275	428-445	REC3884858	3884858	401
REC3852296	3852296	417-421-423	REC3855276	981650	371	REC3884974	3880871	413
REC3852315	3852315	428-429-431	REC3855276	3855276	371	REC3884974	3884974	413
REC3852317	3852317	423	REC3855650	853846	411	REC3886431	3886431	291
REC3852350	3852350	428-442	REC3855650	876317	411	REC3887328	3842442	384
REC3852352	3852352	438-449	REC3855650	3855650	411	REC3887328	3887328	384
REC3852454	3852454	423	REC3856002	3856002	428-429-431-445	REC3887373	3887373	413
REC3852455	3852455	323	REC3856844	3856839	411	REC3887761	3887761	346
REC3852464	3852464	464	REC3856844	3856844	411	REC3887761	21951358	346
REC3852467	3852467	320-322	REC3856961	3856961	353	REC3887761		341-347
REC3852476	3852476	323	REC3857140	3857140	436	REC3888177		462-477
REC3852535	3852535	438	REC3857176	3856176	423	REC3888555	3888555	439
REC3852538	3852538	318-319-320-321-322-324	REC3857176	3857176	420-421-423-425	REC3888916	3888916	439-448-478
REC3852548	3852548	438	REC3857521	3857521	410	REC3888917	876392	446
REC3852550	3852550	438	REC3857522	3857522	410	REC3888917	3888917	424-446
REC3852551	3852551	438-439	REC3857523	3857523	409-410	REC3889782	3889782	424
REC3852555	3852555	411-439	REC3857524	3857524	409-410	REC3889784	3889784	432-433
REC3852558	3852558	439	REC3857533	3857533	404	REC3889786	3889786	432-433-434
REC3852560	3852560	423-439-479	REC3857650	3857650	372	REC3889788	3889788	439
REC3852568	3852568	423	REC3857675	3857675	428	REC3889964	3889964	320-322-324-327
REC3852602	3852602	323	REC3857835	3857835	464	REC391-5090	835304	389-390
REC3852696	3852696	320322-323-324-448	REC3857954	3857954	337-338-342	REC391-5090Q1		390
REC3852830	3852830	320-322-323-324	REC3858077	3858077	407	REC392-6324Q1		389
REC3852865	3852865	417-428	REC3858081	3858089	403	REC392-6325Q1		389
REC3852866	3852866	428-429-431-432-433-434	REC3858212	3858212	411	REC392-9086T	841926	389
REC3852959	3852959	428-429-431	REC3858212	21652399	411	REC392-9766	3853815	389
REC3853283	3853283	318-377	REC3858261	3850809	373	REC393831	3850813	423
REC3853341	3853341	279-281	REC3858261	3857986	373	REC39631		422-438
REC3853378	3853378	318	REC3858261	3858261	373	REC398042	3850984	428-443
REC3853397	3853397	318	REC3858437	3853917	450	REC4-17ALU		468
REC3853423	3853423	410-423-318	REC3858457	852206	442	REC4-19ALU		468
REC3853430	3853430	318	REC3858457	872891	442	REC40005192	40005192	441
REC3853431	3853431	318	REC3858457	3856070	442	REC40005334	40005334	391-393
REC3853434	3853434	323	REC3858457	3858457	427-442	REC40005775	40005775	303
REC3853536	3853536	464	REC3858458	872872	442	REC40155	3852224	362
REC3853628	3853628	318	REC3858458	3856069	442	REC41400		384
REC3853787	3853787	383	REC3858458	3857307	442	REC418411	418411	339-351
REC3853799	3853799	353-477	REC3858458	3858458	442	REC418412	418412	351
REC3853801	3853801	389	REC3858458	3858458	442	REC418445	418445	331-351
REC3853804	3853804	413	REC3858462	966700	464-471	REC418737	418737	314-315
REC3853854	3853854	409-410	REC3858462	3858462	464	REC419310	419310	286
REC3853855	3853855	409-410	REC3858714	3858714	373	REC419310	419763	286
REC3853856	3853856	409-410	REC3858941	3858941	374	REC419643	419643	314-316
REC3853857	3853857	409-410	REC3858984	3858984	394	REC419678	419678	287
REC3853934	3853934	428-433	REC3859050	3859050	417-443	REC419734	419734	314
REC3853962	3853962	450	REC3859078	3859078	395	REC419735	419735	314
REC3853983	3853983	353-476-477	REC3859082	3859082	386	REC430020	430020	351
REC3854001	3854001	392-394	REC3859082	3861323	386	REC430039	430039	287
REC3854002	3854002	392-395	REC3860079	3860079	461-462	REC463075	463075	316
REC3854003	3854003	392-394	REC3860086	3860086	462	REC46335	3853404	318-320-322-323
REC3854018	3854018	377-378	REC3860092	3860092	464-477	REC463377	463377	460-463
REC3854020	3854020	376-378-379	REC3860183	3860183	425	REC463395	463395	314
REC3854053	3854053	371	REC3860232	3860232	421-425	REC463526	463526	314
REC3854077	3854077	394	REC3860384	3858139	448	REC463739	463739	314-315
REC3854105	3854105	376-378-379	REC3860384	3860384	448-478	REC463902	463902	316
REC3854138	3854138	404	REC3860703	856513	338	REC463902	955103	316
REC3854158	3854158	383	REC3860703	3860703	338	REC463903	463903	316
REC3854159	3854159	383	REC3860808	3860808	436	REC463905	463905	316
REC3854161	3854161	395	REC3860842	3860842	423	REC466382	466382	315
REC3854217	3854217	391	REC3861267	3861267	395	REC466383	466383	315
REC3854218	3854218	391	REC3861375	3861375	403	REC466384	466384	315
REC3854247	3854247	408	REC3861376	3861376	404	REC466386	466386	315
REC3854249	3854249	433	REC3861985	3861985	393-395	REC468305	468305	315
REC3854260	3854260	390-392	REC3862228	3851218	362	REC471034	471034	367-472-473
REC3854261	3854261	390-392	REC3862228	3852413	362	REC477024	192211	316
REC3854286	3854286	345-347	REC3862228	3862228	362	REC477024	463903	316
REC3854311	3854311	390-392	REC3862287	3862287	476-477	REC477024	477024	316
REC3854311	3854311	392	REC3862387	3862387	419	REC477026	192426	316
REC3854331	3854331	390	REC3862500	3862500	320-322-324-383	REC477026	477026	316
REC3854480	3854480	417-423-424	REC3862500	38622500	318	REC478736	478736	368
REC3854548	3854548	390-392	REC3862523	3862523	334-335	REC478736	21707133	368
REC3854549	3854549	392	REC3862867	3862867	419-424	REC479956	479956	319-320-321-322-324
REC3854549	3862014	390	REC3863007	3849411	411	REC494MINORKIT		349
REC3854595	3854595	428-429-431	REC3863007	3849413	411	REC53773		320
REC3854601	3854601	431	REC3863007	3855535	411	REC53911		322
REC3854624	3854624	429-431	REC3863080	3863007	411	REC57-36356	966974	465-473
REC3854625	3854625	429-431	REC3863083	3863080	419-447	REC57-96834Q	952141	464
REC3854905	3854905	387	REC3863084	3863083	419-447	REC59830A7	3850815	423
REC3855017	3855017	378-379	REC3863084	3863084	419	REC6842160	6842160	303
REC3855081	3855081	423-424-425-428-432-433-434-479	REC3863085	3863085	419-424	REC6842273	6842273	303
REC3855182	3855182	374	REC3863090	3858303	446	REC70720		370
REC3855194	3855185	383	REC3863090	3863090	428-433-446	REC70817B	3853226	313
REC3855194	3855194	383	REC3863130	3863130	386-393	REC723MINORKIT		349
REC3855269	3853567	327	REC3863191	3863191	320-322-323-324	REC75832T	853255	420
REC3855269	3854427	327	REC3863450	3863450	318-320-322-323-324-449	REC76104		378-379
REC3855269	3855269	323-327	REC3883777	3883777	439	REC803148	3855296	386
REC3855271	3850913	327	REC3883845	3589554	295	REC803356	3588879	303
REC3855271	3853568	327	REC3883845	3883845	295	REC803762	803762	450
REC3855271	3854428	327	REC3884548	3884548	297	REC804190	804190	447
REC3855271	3855271	323-327	REC3884701	3583856	329	REC804190	813967	437
			REC3884701	3884701	329-331	REC804695	804695	350
			REC3884858	3803577	401	REC805222A1	3857449	391-392
			REC3884858	3803940	401	REC805223T	3854527	383

REF.	R.O./OEM	PAG	REF.	R.O./OEM	PAG	REF.	R.O./OEM	PAG
REC805226A1	3855184	386	REC841263	841263	388	REC859093	840405	291
REC806341	806341	317	REC841294	841293	378	REC859093	859093	291
REC806624	806624	437	REC841693	841693	343	REC859094	840328	290
REC807036	807036	352	REC841994	841994	378	REC859094	859094	290
REC807078	807078	385	REC842080	842080	315	REC859107	859107	298
REC807964A1		391-392	REC842280	842280	368-472-473-474	REC859120	802399	296
REC813967	813967	437-447	REC842913	842913	331	REC859120	859120	296
REC814301	814301	441	REC843323	843323	450	REC859134	838127	290
REC814332	814332	435-442	REC845294	845294	380	REC859134	859134	290
REC814356	814356	435-441	REC845294	3802033	380	REC859135	859135	290
REC814388	814388	435-441	REC846037	846037	380	REC859135	3875376	290
REC814390	814390	435-441	REC846037	3802020	380	REC859137	833453	290
REC814396	814396	435-442	REC847573	847573	358	REC859137	859137	290
REC814419	814419	435-441	REC847605	847605	385	REC859140	819720	298
REC8149182	8149182	355-475	REC847741	847741	367-472-473-474	REC859140	819723	298
REC817377		391-392	REC850888	850888	426-441-442-467	REC859140	859140	298
REC818184	818184	311	REC850889	850889	426-442-467	REC859145	833598	297
REC823426A1	855889	378	REC85122800	85122800	481	REC859145	859145	297
REC824326002	3855807	275	REC851407	851407	417-427-429- 431-432-434-447	REC859145	897322	297
REC824677	824677	377	REC851430	851430	408-437	REC859150	859150	291
REC826493	826493	371	REC852212	852212	417-427-429- 431-432-434	REC859150	1544109	291
REC827151	827151	383	REC852705	852705	421-425	REC859151	833070	290
REC827247	827247	350	REC852839	852839	409	REC859151	859151	290
REC82744	82744	319-352	REC852868	852868	437-447	REC859152	829214	291
REC82745	82745	352	REC853048	853048	435-437	REC859152	829531	291
REC82745	997641	317	REC853175	853175	435	REC859152	859152	291
REC829207	829207	464-471	REC853484	853484	421	REC859155	858503	292
REC829433	829433	339-344	REC853542	853542	420	REC859155	859155	292
REC829487	829487	299	REC853678T	3857487	386	REC859171	21501189	313-314
REC829587	829587	385	REC853759	853759	408-437	REC859194	859194	298
REC829592	829592	352	REC853760	853760	408-437	REC859194	3875382	298
REC829620	892260	314	REC853808	853807	432	REC859428	859428	371
REC829714	829714	338-350	REC853808	853808	417-429-432- 434-447	REC859494	859494	374
REC829913	829913	365-471-474	REC853808	853808	447	REC859642	859642	306
REC831009	806256	344	REC853808	853871 +		REC859647	859647	291
REC831009	831009	344	REC853808	853807	431	REC859791	859791	308
REC831009		337	REC853808	853808		REC859807	859807	311
REC831617	831617	350	REC853868	853868	417-420-421- 423-425-447	REC859836	859836	329-331
REC831622	831622	337-350	REC853998A1		374	REC859836	3587410	329
REC831986	831986	461	REC854031	854031	441	REC859945	859945	308
REC832191	832191	426	REC854040	854040	426-428	REC859949	859949	311
REC832534	832534	435-442	REC854045	854045	426-442-467	REC860388	860388	465-472
REC832570	832570	420	REC854047	854047	442	REC860920	860920	358
REC832669	832669	420-421	REC854047	854077	467	REC860971	3582851	303
REC832675	832675	420-421-425	REC854047	854047	467	REC861019	861019	460
REC832820	832820	435-441	REC854541	854541	426	REC861103	861103	374
REC832831	832831	449	REC854935	854935	319-321	REC861250	860684	300
REC832846	832846	441	REC855297	841600	371	REC861250	861250	300
REC832846	851452	435	REC855297	855297	371	REC861250	1544124	300
REC832846	854031	435	REC855389	831778	450	REC861251	859032	300
REC833188	833188	314	REC855389	841895	450	REC861251	860685	300
REC833274	833274	290	REC855389	855389	450	REC861251	861251	300
REC833878	833878	343	REC855506	855506	460-463	REC861251	1542247	300
REC833996	833996	350	REC855507	855507	461	REC861255	861255	375
REC834337	834337	366-414	REC855513	855513	288	REC861260	838697	380
REC834337	897321	366	REC855617	855617	451	REC861260	860918	380
REC834337	22057107	366	REC855686	855686	360-362-476	REC861260	861260	380
REC834337		471-474	REC855694	835550	450	REC861260	3802061	380
REC834751	834751	319-321-449	REC855694	855648	450	REC861260	3802070	380
REC834871	834871	317	REC855694	855694	450	REC861263	861263	358
REC834975	834975	389	REC855728	855728	343	REC861431	861431	451
REC835581	835581	355	REC855967	855967	288-317	REC861473	861473	367
REC835702	835702	389	REC856004	856004	355	REC861473	861826	367
REC838066	838066	296	REC856028	856028	317	REC861473	3808605	367-474
REC838637	833637	314	REC856036	856036	319	REC861476	859746	367
REC838638	838638	314	REC856042	856042	319	REC861476	861476	367
REC838652	838652	296	REC856044	824633	288	REC861476		471
REC838653	838653	296	REC856044	856044	288-317	REC861477	861477	365
REC838654	838654	297	REC856472	856472	378	REC861477	3580096	365
REC839195	839195	408-435	REC857618	857618	319-321	REC861477	3841080	365
REC839253	839253	420-421-425	REC857621	419628	286	REC861477	21190113	365
REC839253	853670	444	REC857621	857621	286	REC861477		474
REC839423	839423	426-442	REC857621	857621	286	REC861563	861563	461-463
REC839534	839534	426-442	REC857621	875543	286	REC861564	861564	463-465-471-472
REC84-817376T01	3854084	392	REC857621	876783	286	REC861603	859726	300
REC840074	840074	384	REC858464	858464	447	REC861603	861603	300
REC840115	840115	296	REC858467	858467	339-344	REC861688	861688	375
REC840115	3875384	296	REC858488	858488	368-471-472	REC861698	861698	315
REC840384	833997	343	REC858979	858979	358	REC861699	861699	315
REC840384	840384	343	REC859002	859002	331	REC861725	861725	375
REC840569	840569	290	REC859011	859011	331	REC861822	861822	299
REC840648	818035	300	REC859015	803374	298	REC861823	861823	303
REC840648	840648	300	REC859015	859015	298	REC861860	861860	313
REC840785	803723	343	REC859038	842990	299	REC861860	861860	314
REC840785	804693	343	REC859038	859038	299	REC861907	861907	329-330-331
REC840785	840785	343	REC859039	859039	299	REC8631533	8631533	386
REC840902	840902	298-331	REC859039	1542219	299	REC8631652	861700	313-315
REC840902	3875050	298	REC859042	840572	296	REC8631652	877072	313-315
REC840902		328	REC859042	859042	296	REC8631652	877073	313-315
REC841161	841161	371	REC859043	840440	296	REC8631652	8631652	313-315
REC841177	841177	404	REC859043	859043	296	REC863169	863169	385
REC841243	841243	389	REC859044	840461	296	REC863946	863946	387
REC841262	241710	388	REC859044	859044	296	REC8642665	8642665	296
REC841262	841262	388				REC864297T01	3858979	385

REF.	R.O./OEM	PAG.	REF.	R.O./OEM	PAG.	REF.	R.O./OEM	PAG.
REC864315	863750	366	REC875822	22303438	449	REC876377	876377	292
REC864315	864315	366	REC876040	876040	403	REC876377		290
REC8653103	8653103	384	REC876054	876054	301	REC876378	875501	300
REC865428	848275	381	REC876069	849270	369	REC876378	876378	300
REC865428	848276	381	REC876069	876069	369	REC876379	875508	293
REC865428	864878	381	REC876069	876070	369	REC876379	876379	293
REC865428	865334	381	REC876069	3830004	369	REC876379		290
REC865428	865428	381	REC876069	471-472-473-474		REC876380	875572	293
REC8658726	8658726	386	REC876073	876073	446	REC876380	876380	293
REC866653	866653	465-472-473	REC876080	82812	353	REC876380		290
REC866835	866835	385	REC876080	824912	353	REC876381	875562	300
REC866836	866836	385	REC876080	875781	353	REC876381	876381	300
REC8676498	3803645	401	REC876080	875790	353	REC876382	875715	300
REC8676498	8676498	401	REC876080	876080	353	REC876382	876382	300
REC8692305	8692305	362-368-474-477	REC876080	876080	354-471-475	REC876383	875573	301
REC8692438	8692438	296	REC876080	876797	353	REC876383	876383	301
REC870690	870690	388	REC876080		355	REC876384	875554	301
REC872066	872066	383	REC876099	838660	305	REC876384	876384	301
REC872082	872082	426-442	REC876099	867975	305	REC876388	875505	300
REC872096	872096	435-436-441	REC876099	876099	305	REC876388	876388	300
REC872096	876507	441	REC876114	876114	306	REC876389	875503	300
REC872096		479	REC876144	876144	298	REC876389	876389	300
REC872334	872334	437	REC876161	876161	306	REC876391	875720	415-443
REC872338	872338	437	REC876185	463505	369	REC876391	876391	415-443
REC872362	872362	408	REC876185	863344	369	REC876393	875588	289
REC872722	872722	437	REC876185	876185	369	REC876393	876393	289
REC872752	872752	435-436-437-441	REC876185		471-472-473	REC876393	876433	289
REC872753	872753	436	REC876266	876266	420-421-445	REC876416	875438	295
REC872756	872756	436	REC876267	876267	427-444	REC876416	876416	295
REC872812	872812	408-437	REC876268	876268	444	REC876417	875388	294
REC872845	872845	437	REC876278	826341	435-441-479	REC876417	875567	294
REC872986	872986	436	REC876279	853223	435-441	REC876417	876417	294
REC873066	873066	383	REC876279	876279	441	REC876417		291
REC873228	873228	409	REC876279		479	REC876427	876032	302
REC873229	873229	409	REC876294	875826	447	REC876427	876427	302
REC873534	873534	436	REC876294	876294	420-421-447-478	REC876427		300
REC874502	874502	401	REC876294	897889	447	REC876431	876430	293
REC874502	3587216	401	REC876294		479	REC876431	876431	293
REC874502	3803650	401	REC876300	875587	287	REC876431		290
REC874502	3803846	401	REC876300	876300	287	REC876448	876023	289
REC874502	3803911	401	REC876300		286	REC876448	876448	289
REC874502	3840181	401	REC876301	875678	287	REC876511	876511	312
REC875303	875303	311	REC876301	876301	287	REC876515	876515	310
REC875306	875306	308	REC876301		286	REC876516	876516	310
REC875307	875307	308	REC876302	876022	287	REC876519	876519	310
REC875331	875331	311	REC876302	876302	287	REC876520	876520	310
REC875334	875334	308	REC876302		286	REC876548	876548	305
REC875383	875383	348	REC876303	876071	287	REC876548	876611	305
REC875387	875387	302	REC876303	876303	287	REC876554	876554	366-471
REC875387	875421	302	REC876303		286	REC876588	876588	446
REC875407	875407	378	REC876304	876072	289	REC876614	876614	405
REC875439	875439	301	REC876304	876304	289	REC876631	875848	448
REC875498	875498	306	REC876305	424299	353	REC876631	876631	420-436-437-448-478
REC875499	875499	306	REC876305	835177	353	REC876631		479
REC875512	804186	447	REC876305	875794	353	REC876633	876633	420-448-478
REC875512	875512	447	REC876305	876305	353	REC876655	876655	302
REC875512	875827	447	REC876305		475-476	REC876774	876106	302
REC875541	875320	305	REC876306	875403	289	REC876774	876362	302
REC875541	875541	305	REC876306	876306	289	REC876774	876531	302
REC875541	875655	305	REC876307	876307	290-292	REC876774	876774	302
REC875550	875550	304	REC876308	876308	290-292	REC876774		300
REC875551	875551	304	REC876310	876310	291-293	REC876775	3586758	307
REC875574	875574	348	REC876314	875509	301	REC876793	876560	334
REC875574	876081	348	REC876314	876314	301	REC876793	876793	334
REC875575	875575	337-343-344-345-347-348	REC876337	875402	287	REC876794	876544	334
REC875579	875579	304	REC876337	875533	287	REC876794	876794	334
REC875580	875580	353-471-475	REC876337	876335	287	REC877349	877349	354-471
REC875584	875584	348	REC876337	876337	287	REC877355	877355	354-474
REC875676	875676	305	REC876341	875561	292	REC877373	875759	348
REC875697	875697	346	REC876341	876341	292	REC877373	876088	348
REC875697	875814	346	REC876342		290	REC877373	876529	348
REC875697	21951364	346	REC876342	875400	289	REC877373	877373	348
REC875698	875698	348	REC876342	876342	289	REC877419	877419	301
REC875698	21951420	348	REC876349	875634	302	REC879194401	21124846	332-333-335
REC875698		348	REC876349	876349	302	REC883166A2	3861570	407
REC875722	275052	305	REC876349		300	REC8845		373
REC875722	875652	305	REC876356	876356	286	REC885176	3858969	374
REC875722	875707	305	REC876358	875569	286	REC885195	885195	470
REC875722	875722	305	REC876358	876358	286	REC8865		372
REC875741	875741	443	REC876358		286	REC886MINORKIT		349
REC875741	876266	443	REC876359	875570	287	REC888596	888596	329-331
REC875756	+ 876267	443	REC876359	876359	287	REC889455	889455	419
REC875756	875756	348	REC876359		286	REC889486	889486	297
REC875757	875757	301	REC876361	876105	302	REC889672	889672	415
REC875769	875769	349	REC876361	876361	302	REC889970	889970	375
REC875769	21951410	349	REC876361		300	REC890MINORKIT		349
REC875783	875783	354-471	REC876376	875553	293	REC892617	3808516	385
REC875785	875785	354-471-472-473-474	REC876376	876376	293	REC897367	897367	426-442-467
REC875791	831040	353	REC876376		290	REC897426	897426	426-446
REC875791	875791	353	REC876377	875500	292	REC897682	897682	420-421-479
REC875791		475	REC876377	875502	292	REC897726	897726	447
REC875796	875796	354-453-471	REC876377	875504	292	REC898253013	3858977	390-391-393
REC875822	875822	449-478	REC876377	876374	292	REC898253013	898253013	390-391
			REC876377	876375	292			

REF.	R.O./OEM	PAG	REF.	R.O./OEM	PAG	REF.	R.O./OEM	PAG
REC89825302	508935	390	REC976483	976483	465-472	RM21252967	21252967	311
REC898253T22	3858975	391-393	REC977542	977542	465-471-472	RM21255090	3812520	338
REC898253T23	3859019	390-393	REC978217		463	RM21255090	21255090	338
REC8M0068784	3857532	384	REC978482	978482	465-474	RM21255090		342
REC8M0073435	3854858	371	REC978750	978750	463-464-475-476	RM21277185	3841482	448
REC8M0077616	3854512	386	REC979254	979254	436	RM21277185	3886847	448
REC8M0087834	3858987	387	REC982209	508932	390	RM21277185	21277185	448-478
REC8M0087834	3859020	387	REC982230	841054	361	RM21301848	21301848	306
REC8M6001217	835308	389-390	REC982230	855952	361	RM21314684	21314684	464-474
REC8M6001219	835705	389	REC982230	877765	361	RM21319767	21319767	308
REC8M6001249	835704	389	REC982230		475-476	RM21325765	842993	330
REC9-29307		388	REC982570		463	RM21325765	842993	331
REC9-35176		377	REC984068	984068	421-425	RM21325765	21325765	330
REC9139282	462623	286	REC984222	984222	419	RM21325765		331
REC9139282	9139282	286	REC984223	984223	419	RM21399021		462
REC9139284	430107	286	REC984224	984224	419	RM21405494		463
REC9139284	461056	286	REC984225	984225	419	RM21407026	21407026	465
REC9139284	461618	286	REC984491	3854019	362	RM21412646	21412646	355
REC9139284	913928	286	REC985052		378-379	RM21412647	21412647	355
REC9139284	3855409	286	REC993430	993430	419	RM21492771	466987	366
REC925050	925050	408-437	REC994130	994130	316	RM21492771	829993	366
REC925052	905052	421	REC997641	949918	352	RM21492771	3825133	366
REC925064	925064	437	RECC2		469	RM21492771	21492771	366
REC925093	925093	425	RECC3		469	RM21548739	3863347	412
REC925093	925093	417-420-421-423-424-338-339	RECC4		469	RM21548739	3863405	412
REC925256	925256	415-420-425-426-427-436-437-444	RECC6		469	RM21548739	3863406	412
REC925258	925258	427	RECEFP-KT		373	RM21548739	3863407	412
REC925259	925259	419-432-434-435-436-444	RECGS00530		365	RM21548739	21548739	412
REC925260	925260	414-419	RECGS01030		365	RM21608511	3594444	373
REC925261	925261	426	RECGS01830		365	RM21608511	3860210	373
REC92995-08600	3852193	424	RECKIT280DP		479	RM21608511	3861355	373
REC93568		362	RECKIT290DP		479	RM21608511	21545138	373
REC940136	940136	319-321	RECKIT290SP		479	RM21608511	21608511	373
REC940191	940191	419-435-436	RECKITDP	RM3860881	408	RM21608511		362-372
REC941816	941816	420	RECKITDP2	RM872612	408	RM21610333	3854086	376
REC941820	941820	435	RECKITDPC-D-E		479	RM21610333	3857982	376
REC941907	941907	319-321-415	RECKITDPH		479	RM21610333	21132437	376
REC942336	942336	319-321	RECKITDPR		479	RM21610333	21610333	376
REC942547	942547	319-321	RECKITDPS-SX		479	RM21632901	21632901	368
REC942615	942615	420	RECKITSPE		479	RM21632901	22030852	368
REC942791	942791	417	RECKITSXA		479	RM21745117	21745117	412
REC945624	945624	419	RECOILCOOLER		332	RM21745117	22256625	412
REC946056	946056	439	RECPIN4		411	RM21745117	22452003	412
REC946438	946438	417-429-431	RECPIN4.5		411	RM22197130	3841481	448
REC947893	947893	352	RECPIN6		411	RM22197130	3854127	448
REC947894	947894	352	RECRK21069		370	RM22197130	22197130	439
REC947904	947904	437	RECTOOLTRIM1		411	RM22197130	22197130	448-478
REC949656	949656	414-417-424	RECTOOLTRIM2		411	RM22197130		448-479
REC951924	951924	421	RECTOOLTRIM3		411	RM243801	243801	388
REC951936	951936	419-424	RECTOOLTRIMKIT		411	RM30731740	30731740	307
REC952980	952980	449	RECV11010	11010	342	RM30731809		463-474-475
REC955893	955893	429-431-434	RECV11010	861812	342	RM30750678	30750678	307
REC955974	955974	420-421-426-427-444-479	RECV11010	3578536	342	RM30788490		475
REC955981	955981	417-429-431-479	RECV11010	3884972	342	RM31261191	8683212	365
REC955989	955989	414-420-421-479	RECV11010	6600756	342	RM31261191	31261191	365
REC956000	956000	420-421-425-444	RECHOL17-6		377	RM31261191		474
REC956590	956590	421	RM1542287	1542287	296	RM3517857	418432	362-367
REC959794	959794	321	RM184691	184691	417-427-431-432-434	RM3517857	430143	362-367
REC959796	959796	319	RM184691	194691	429	RM3517857	1266286	362-367
REC966207	966207	408-437	RM20856959	20856959	312	RM3517857	3517857	362-367
REC966382	966382	463-475	RM20867177	20867177	311	RM3580303	3580303	314
REC966383	966383	464-471	RM20867178	20867178	309	RM3580304	3580304	314
REC966387	966387	465	RM20867661	20867661	311	RM3580337	3580337	306
REC966694	966694	463-475	RM20867751	20867751	309	RM3580338	3580338	306
REC966707	966707	464-471	RM21132385		462-477	RM3580365	3580365	354-474
REC966871	966871	352	RM21132390	3861034	464	RM3580546	3580546	306
REC966891	966891	463-463-475	RM21132390		462-477	RM3580547	3580547	306
REC966900	966900	464-474	RM21132674	21132674	413-478	RM3581114	3581114	449
REC966903	966903	464-474	RM21132989	3884512	309	RM3581115	3581115	449
REC966906	966906	464-465-471-472-474	RM21132989	21132989	309	RM3581460	3581460	465-471
REC966914	966914	464	RM21132990	21132990	311	RM3581621	861474	366
REC966931	966931	464-471	RM21139810	21139810	365-475	RM3581621	861475	367
REC966933	966933	464-471	RM21186281	3580478	314	RM3581621	3581621	366
REC966942	966942	464-471	RM21186282	21307714	314	RM3581621	21549544	366
REC966978	966978	465-471-472	RM21212798	3812522	337	RM3581724	860786	387
REC966990	966990	464	RM21212798	21212798	337	RM3581724	3581062	387
REC966990	966990	471	RM21212798		342	RM3581724	3581724	387
REC967111	967111	463-464-476	RM21212798		337	RM3582357	3582357	368
REC967344	967344	340-417-421-423-424-425	RM21212801	21131568	337	RM3582357	21646645	368
REC967707	967707	436	RM21212801	21212801	337	RM3582357	21782391	368
REC968048	968048	398	RM21212801		342	RM3582424		463
REC968955	968955	316	RM21214595	3812696	337	RM3582732	3582732	368
REC968955	1542263	316	RM21214595	3861417	337	RM3582732	22030848	368
REC968955	60112158	317	RM21214595	3862485	337	RM3583443	3583443	366
REC969071	969071	426-427	RM21214595	21214595	337	RM3583443	21718912	366
REC969073	969073	426	RM21214595		342	RM3583693	3583693	307
REC973593	973593	425	RM21214596	3812697	338	RM3584086	3584086	464-474
REC975672		338	RM21214596	3858229	338	RM3584145	3584145	369-475
			RM21214596	3862487	338	RM3586324		462
			RM21214596	21214596	338	RM3586325		462-477
			RM21226191	3884515	309	RM3586326		462
			RM21226191	21226191	309	RM3586871	3586871	309
			RM21228429	21228429	292	RM3586873	3586873	309
						RM3586875	3586875	309

REF.	R.O./OEM	PAG	REF.	R.O./OEM	PAG	REF.	R.O./OEM	PAG
RM3586877	3586877	309	RM3858873	3858873	320-322-323-324-328-438	RM854661	854661	421
RM3586883	3885323	311	RM3860087	3860087	464-476	RM854704	854704	408-437
RM3587072	3587072	401	RM3860093	3860093	464	RM854705	854705	408-437
RM3587651	3587651	318-320-322-323-324-338	RM3860230	3860230	420	RM854977	854977	467
RM3588435	3588435	299-382	RM3860230	3860230	421	RM854978	854978	467
RM3588437	3588437	355	RM3860230	3860230	425	RM854979	854979	467
RM3588684	3588683	326	RM3860252	3860252	428-429-431	RM854982	854982	467
RM3588684	3588684	318-326	RM3860842	3860842	417-423-424	RM854983	854983	467
RM3588865	3588865	372	RM3860881	872837	407	RM854984	854984	467
RM3807613	3807613	417-420-421-423-424-425	RM3860881	3860881	407	RM854986	854986	467
RM3809625	3809625	464-474	RM3860881		411	RM854992	854992	467
RM3809662	3809662	314	RM3861459	3852362	326	RM854993	854993	467
RM3812159	3812159	464-474	RM3861459	3861459	324-326	RM854994	854994	467
RM3812472	3812472	306	RM3861500		462	RM854997	854997	467
RM3812474	3812474	306	RM3861501		462	RM854998	854998	467
RM3817517	3817517	366	RM3862228	3851218	362	RM854999	854999	467
RM3817517	3828838	366	RM3862228	3852413	362	RM855409	855409	336
RM3817517	3839469	366	RM3862228	3862228	362	RM855410	855410	336
RM3819722		450	RM3862627	3862627	320-322-324-327	RM855423	855423	336
RM3819723		450	RM3862627	3862904	327	RM855428	855428	460
RM3819724		450	RM3863189	3863189	320-322-327	RM855433	855433	336
RM3819725		450	RM3863450	3863450	322	RM855686-2	855686	362
RM3819726		450	RM3883257	3883257	438-439	RM855791	855791	336
RM3819727		450	RM3883844	1275549 + 21584008	299-381	RM856083	856083	336
RM3819728		450	RM3884010	3884010	315	RM856100	856100	336
RM3827069	829161	367	RM3884015	3884015	315	RM856239	831972	460
RM3827069	829390	367	RM3884517	3884517	308	RM856239	855473	460
RM3827069	3827069	367	RM3884528	3884528	314	RM856239	856239	460
RM3827069	21549542	367	RM3884557	3884557	311	RM857624	857624	409
RM3838952	3827167	368	RM3884561	3884561	311	RM858955	858955	328-449
RM3838952	3838952	368	RM3885196	3850683	407	RM858955	858955	328-449
RM3838952		473	RM3885196	3885196	407	RM859834	859834	298-331-381
RM3840335	3588378	365	RM3885250	3587858	460	RM860396	860396	328-449
RM3840335	3840335	365	RM3885250	3587859	460	RM860409	860409	358
RM3840335	21624740	365	RM3885250	3861010	460	RM860993	860433	387
RM3840525	3589316	367	RM3885250	3885250	460	RM860993	860434	387
RM3840525	3840525	367	RM3885250		460-462	RM860993	860435	387
RM3840525		474	RM3885324	3885324	311	RM860993	860993	387
RM3841366	3841366	403	RM3885870	388587	478	RM861473	861473	367
RM3842015	3842015	354-474	RM3885870	3885870	448	RM861473	861826	367
RM3847644	3847644	362	RM3888323	3850491	413	RM861473	3808605	367
RM3850245	3850245	376	RM3888323	3850492	413	RM861476	859746	367
RM3850430	3850430	464-476	RM3888323	3888323	413	RM861476	861476	367
RM3850559	3850559	363-476	RM3888555	3888555	438	RM861477	861477	365
RM3851334	3851334	427	RM3889124		462-477	RM861477	3580096	365
RM3851482	3851482	469	RM3889127		462	RM861477	3841080	365
RM3851482	21258482	469	RM466634	466634	367	RM861477	21190113	365
RM3851483	3851483	469	RM466634	21707134	367	RM861657	861657	358
RM3851483	21258483	469	RM471034	471034	367	RM861858	859650	314
RM3851484	21258484	469	RM477556	471392	368	RM861858	861858	314
		426-427-428-429-431-432-433-434	RM477556	477556	368	RM861859	859656	314
RM3852268	3852268	429-431-432-433-434	RM477556	21707132	368	RM861859	861859	314
RM3852288	3852288	334-335	RM477556	21707132	368	RM861906	861906	329-331
RM3852289	3852289	334-335	RM4785974	423135	367	RM861906	21190094	329
RM3852390	3852390	417-420-421-423-424-425	RM4785974	4785974	367	RM861911	861911	354-474
RM3852418	3852418	423	RM478736	478736	368	RM861954	861954	306
RM3852504	3852504	464	RM478736	21707133	368	RM861955	861955	306
RM3852516	3852516	423	RM6210419	6210419	354-471	RM8631650	8631650	315
RM3852573	3852573	410	RM813316	813316	467	RM8631651	8631651	315
RM3852607	3852607	464-476	RM813317	813317	467	RM872027	872027	421
RM3852648	3852648	410-423-424-438-439	RM814611	814611	467	RM872215	872215	412
RM3852958	3852958	410	RM814612	814612	467	RM872363	872363	408
RM3853424	3853424	410-423	RM814615	814615	467	RM872549	872549	427-442
RM3853608	3853608	449	RM814616	814616	467	RM872612-7	853439	407
RM3853825	3853825	409	RM814626	814626	467	RM872612-7	854610	407
RM3854643	3854643	464-476	RM814627	814627	467	RM872612-7	872612	407
RM3854874	3854874	320-327	RM814628	814628	467	RM872612-7		411
RM3856365	21258485	469	RM814631	814631	467	RM872614	853655	442
RM3856366	3856366	469	RM814632	814632	467	RM872614	854057	442
RM3856366	21258486	469	RM814633	814633	467	RM872614	854666	442
RM3856367	3856367	469	RM826422		338	RM872614	872614	427-442
RM3856367	21258487	469	RM828254		450	RM873183	873183	435
RM3856502	3856502	417-420-421-423-425	RM828422		450	RM875483	875483	308
RM3857148	3857148	421	RM828526		450	RM875485	875485	308
RM3857391	3857391	334-335	RM828527		450	RM875491	875491	310
RM3857431	3857431	410	RM829205	829205	336	RM875492	875492	310
RM3857470	3857470	410	RM831834-7	831834	319-326	RM875747	875747	310
RM3857471	3857471	407	RM831960	831960	351	RM875748	875748	310
RM3857588	3857588	410	RM834337	834337	366	RM875750	875750	308
RM3858051	3858051	428	RM834337	897321	366	RM875751	875751	308
RM3858128	3812269	412	RM834337	22057107	366	RM875752	875752	308
RM3858128	3860726	412	RM835440-9	835440	362	RM875753	875753	308
RM3858128	3860883	412	RM835440-9	3852030	362	RM875773	875773	308
RM3858128	3862210	412	RM835440-9	3852412	362	RM875774	875774	308
RM3858128	3862513	412	RM840690	840690	328-331	RM875795	875795	354-474
RM3858128	21910902	412	RM841750	841750	362	RM876294	875826	447
RM3858631	3858631	438	RM841812	841812	403	RM876294	876294	447
RM3858873	3850794	328	RM843228	843228	328-449	RM876294	897889	447
RM3858873	3850796	328	RM847741	847741	367	RM876512	876512	312
RM3858873	3853915	328	RM85108974	85108974	387-481	RM876631	875848	448
RM3858873	3853915	328	RM852904	852904	426-427	RM876631	876631	437-448
RM3858873	3855281	328	RM852984-4	852984	408-437	RM876632	854555	449
			RM854100	854100	435	RM876632	875747	449
			RM854133	854133	435	RM876632	876632	437-449
						RM876633	876633	448

REF.	R.O./OEM	PAG	REF.	R.O./OEM	PAG	REF.	R.O./OEM	PAG
RM876657	876657	309	SOL8712-148-17		466	TEN00715	838929	454
RM876658	876658	309	SOL8712-150-15		466	TEN00716	823661	454
RM876660	876660	309	SOL8811-142-23		466	TEN00716T		454
RM876661	876661	309	SOL8811-143-21	872004	466	TEN00716TP		454
RM876663	876663	309	SOL8811-145-19	872003	466	TEN00717	872793	452
RM876664	876664	309	SOL8811-148-17	872002	466	TEN00718	3854130	452
RM876666	876666	309	SOL8811-150-15	872001	466	TEN00719	833913	454
RM876667	876667	309	SOL8811-153-19	872003	466	TEN00720	833915	454
RM876669	876669	312	SOL8811-153-21		466	TEN00721	828140	454
RM876670	876670	312	SOL8811-155-17	872002	466	TEN00722	873395	452
RM876672	876672	312	SOL8811-158-15	872001	466	TEN00723	876638	452
RM876680	876680	312	SOL8812-142-23		466	TEN00724	872139	452
RM876682	876682	312	SOL8812-143-21	854990	466	TEN00726	3855411	452
RM876683	876683	312	SOL8812-145-19	854989	466	TEN00727	3852970	452
RM876685	876685	312	SOL8812-148-17	854988	466	TEN00728	3858399	453
RM876686	876686	312	SOL8812-150-15	854987	466	TEN00728BIS	3584442	453-478
RM877387	877387	309	SOL8812-153-19	854989	466	TEN00729		453
RM877388	877388	311	SOL8812-153-21	872004	466	TEN00731	41100098	453
RM88-79023A91		404	SOL8812-155-17	854988	466	TEN00732	4100276	453
RM881797	872616	387	SOL8812-158-15	854987	466	TEN00733	3588746	453
RM881797	881797	387	SOL8831-150-15	854996	466	TEN00733	3588748	453
RM888624	888624	355-474	SOL8831-150-17	854997	466	TEN00733	3588750	453
RM9180722	31251996	311	SOL8831-150-19	854998	466	TEN00733/1		453
RM966391		472	SOL8831-150-21	854999	466	TEN00733BIS	3589875	478
RM966912	966912	464-471	SOL8832-150-15	854981	466	TEN00733BIS	3888814	453
RM966953	966953	465-473	SOL8832-150-17	854982	466	TEN00733BIS		479
RM967114	967114	464-465-474	SOL8832-150-19	854983	466	TEN00734	3888305	453
RM967191	967191	463-476	SOL8832-150-21	854984	466	TEN00734	3888306	453
RM967193	967193	465-472-473	SOL8841-156-15	872001	466	TEN00735	3888814	454
RM968971		339	SOL8841-156-17	872002	466	TEN00736	852019	452
RM973534	973534	465-474	SOL8841-156-19	872003	466	TEN00737	3888817	453
RM977313	977313	408-435-437	SOL8841-156-21		466	TEN00738	3599981	453
RM978454	978454	464-476	SOL8841-156-23	854990	466	TEN00739AL	23172849	478
RM981965	981965	420-421	SOL8842-156-15	854987	466	TEN00739AL	40005875	453
RMTUBOVOLVO		408	SOL8842-156-17	854988	466	TEN00742	3861634	453
SED3090900	861906	330-331	SOL8842-156-19	854989	466	TEN00743	3861636	453
SED3090900	21190094	330	SOL8842-156-21	872004	466	TEN00744	3807400	453
SED3091000	845261	329-331	SOL8842-156-23		466	TEN02022T		317
SED3091100	859963	329-331	SOL9511-143-21		467	TENKITVOLVO ELICA3PAL		455
SED3091200	860656	329	SOL9511-145-19		467	TENKITVOLVO280		455
SED3091200	861289	329-331	SOL9511-148-17		467	TENKITVOLVO290		455
SED3091400	865545	330	SOL9511-150-15		467	TENKITVOLVO290-C		455
SED3091400	3826841	330	SOL9512-143-21		467	TENKITVOLVO290-MG-C		455
SED3091400	3829668	330	SOL9512-145-19		467	TENKITVOLVODDP280		455
SED3091400	3830988	330-331	SOL9512-148-17		467	TENKITVOLVODDP290		455
SED3091500	3583856	330	SOL9512-150-15		467	TENKITVOLVODDP290-C		455
SED3091500	3884701	330-331	SOL9513-140-21		467	TENKITVOLVODDPH/ DPR		455
SED3091600	3587159	330	SOL9513-143-19		467	TENKITVOLVOIPS		455
SED3091600	3841510	330	SOL9513-145-17		467	TENKITVOLVOSX		456
SED3091600	21684825	330-331	SOL9513-148-15		467	TENKITVOLVOSXA/DPASA		456
SED3091600	22671213	330	SOL9531-140-19		467	TENKITVOLVOXD-P		456
SED3091600	22948844	330	SOL9531-140-21		467			
SED3094100	876552	332	SOL9531-140-23		467			
SED3094200		332	SOL9531-143-17		467			
SHE09959K	3854286	345-347-475-476	SOL9531-145-15		467			
SHE10615K	835874	345	SOL9532-140-19		467			
SHEG9901	3851623	337	SOL9532-140-21		467			
SHEG9901	3852398	337	SOL9532-140-23		467			
SHEG9901	3855778	337	SOL9532-143-17		467			
SHEG9901	3858847	337	SOL9532-145-15		467			
SHEG9903	3851982	337	SOL9571-148-23		467			
SHEG9903	3852399	337	SOL9571-150-21		467			
SHEG9903	3855079	337	SOL9571-153-19		467			
SHEG9903	3857794	337	SOL9571-155-17		467			
SOL8611-142-23	3817470	466	SOL9571-158-15		467			
SOL8611-143-21	3817469	466	SOL9572-148-23		467			
SOL8611-145-19	3817468	466	SOL9572-150-21		467			
SOL8611-148-17	3817467	466	SOL9572-153-19		467			
SOL8611-150-15	3817466	466	SOL9572-155-17		467			
SOL8612-143-21		466	SOL9572-158-15		467			
SOL8612-145-19	3817473	466	SOLR BX-105		467			
SOL8612-148-17	3817472	466	SSP4206		306			
SOL8612-150-15	3817471	466	STA82910		289-302			
SOL8613-140-21	3817469	466	TEN00700	875810	451			
SOL8613-143-19	3817468	466	TEN00701	875809	451			
SOL8613-145-17	3817467	466	TEN00702	875805	451			
SOL8613-148-15	3817466	466	TEN00703	875815	451			
SOL8614-140-21		466	TEN00704BIS	875821	451			
SOL8614-143-19	3817473	466	TEN00705	875812	451			
SOL8614-145-17	3817472	466	TEN00706	851983	452			
SOL8614-148-15	3817471	466	TEN00706	876286	452			
SOL8641-155-15	3817466	466	TEN00707	832598	452			
SOL8642-145-23	3817470	466	TEN00708	852835	452			
SOL8642-155-15	3817471	466	TEN00709	832934	452			
SOL8651-140-24	3850305	466	TEN00710	852018	452			
SOL8651-145-21	3817469	466	TEN00711	852018	452			
SOL8651-148-17	3817467	466	TEN00713		454			
SOL8651-148-19	3817468	466	TEN00713T		454			
SOL8652-140-24	3850315	466	TEN00713TP		454			
SOL8652-145-21		466	TEN00714	838929	454			
SOL8652-148-17	3817472	466	TEN00714-1		454			
SOL8652-148-19	3817473	466	TEN00714T		454			
SOL8712-143-21		466	TEN00714TPF		454			
SOL8712-145-19		466	TEN00714TPM		454			

# ÍNDICE / TABLE OF CONTENTS / INDICE

## R.O. / OEM --> REF

R.O./OEM	REF	PAG	R.O./OEM	REF	PAG	R.O./OEM	REF	PAG
11010	RECV11010	342	418737	REC418737	314-315	814628	RM814628	467
11043	REC11043	419	418870	REC1378911	288	814631	RM814631	467
11044	REC11044	427-429-431	419310	REC419310	286	814632	RM814632	467
11065	REC11065	419	419628	REC857621	286	814633	RM814633	467
11072	REC11072	426-427	419643	REC419643	314-316	818035	REC840648	300
11096	REC11096	419	419652	REC3582606	314	818184	REC818184	311
12784	REC12784	419	419653	REC3582561	314	819720	REC859140	298
17253	REC17253	435-436	419678	REC419678	287	819723	REC859140	298
17276	REC17276	419-435-436-479	419734	REC419734	314	823661	CM823661	458
38201	REC38201	322	419735	REC419735	314	823661A	CM823661A	458
82744	REC82744	319-352	419763	REC419310	286	TEN00716		454
82745	REC82745	352	423135	REC127695-35150	367	824200	REC3831426	353
82812	REC876080	353	423135	RM4785974	367	824532	HGE4532	288-317-326
125017	REC125017	425-435-436-444-479	424299	REC876305	353	824633	REC856044	288
181620	REC181620	435	430020	REC430020	351	824677	REC824677	377
181804	REC181804	419	430039	REC430039	287	824912	REC876080	353
183247	REC183247	420-421-423-424-425	430107	REC9139284	286	825598	HGE5599	326
183272	REC183272	417-427-429-431-432-434	430143	REC3517857	362-367	825599	HGE5599	317-326
183374	REC183374	426-427	430143	RM3517857	362-367	826341	REC876278	435-441-479
183390	REC183390	426	461056	REC9139284	286	826493	REC826493	371
183391	REC183391	435	461092	REC1378913	288-319	827151	REC827151	383
183512	REC31-86748A1	431	461113	REC1378914	289	827247	REC827247	350
183765	REC183765	419	461618	REC9139284	286	828023	REC3587508	332
183859	REC183859	417-427-429-431-432-434	462623	REC9139282	286	828026	JOH10-32621-2	337
183861	REC183861	342	463075	REC463075	316	828140	TEN00721	454
184642	REC183390	419	463225	REC1378879	288	828726	REC22314183	411
184654	REC184654	419-427-429-431-432-434	463371	REC3582609	314	829161	REC3827069	363-367
184682	REC184682	427-429-431	463377	REC463377	460-463	829161	RM3827069	367
184683	REC184683	417-427-429-431-432-434	463395	REC463395	314	829205	RM829205	336
184691	RM184691	417-427-431-432-434	463412	REC1378645	286	829207	REC829207	464-471
184765	REC184765	417-427-429-431-432	463505	REC876185	369	829214	REC859152	291
184778	REC184778	419	463526	REC463526	314	829390	REC3827069	363-367
188486	PH150-0007	398	463587	REC1378864	289	829390	RM3827069	367
188486	PH150-0007-OE	398	463739	REC463739	314-315	829433	REC829433	339-344
191844	REC191844	437	463828	REC1674083	343	829487	REC829487	299
192211	REC477024	316	463902	REC463902	316	829531	REC859152	291
192212	REC192212	316	463903	REC463903	316	829587	REC829587	385
192426	REC477026	316	463903	REC477024	316	829592	REC829592	352
194691	RM184691	429	463904	REC192212	316	829714	REC829714	338-350
238258	REC238258	388	463904	REC192212	316	829895	JOH10-35098-3	338
241652	REC241652	388	463905	REC463905	316	829913	REC829913	365-471-474
241669	REC241669	388	466382	REC466382	315	829993	REC21492771	366
241710	REC841262	388	466383	REC466383	315	829993	RM21492771	366
243653	REC243653	388	466384	REC466384	315	831009	REC831009	344
243658	REC243658	388	466634	REC21707134	367	831040	REC875791	353
243797	REC243797	388	466634	RM466634	367	831178	JOH10-32058-1	337
243799	REC243799	388	466386	REC466386	315	831617	REC831617	350
243801	RM243801	388	466987	REC21492771	366	831622	REC831622	337-350
243903	REC243903	388	466987	RM21492771	366	831778	REC855389	450
270136	REC270136	310	468305	REC468305	315	831834	RM831834-7	319-326
270137	REC270137	310	471034	REC471034	367-472-473	831960	RM831960	351
270906	REC270906	307	471034	RM471034	367	831972	RM856239	460
270907	REC270907	307	471392	REC21707132	368	831986	REC831986	461
271051	REC271051	310	471392	RM477556	368	832191	REC832191	426
271052	REC271052	310	477024	REC477024	316	832534	REC832534	435-442
271054	REC271054	310	477026	REC477026	316	832570	REC832570	420
271063	REC271063	310	477556	REC21707132	368	832598	CM832598	457-478
271064	REC271064	310	477556	RM477556	368	832598	CM832598A	457-478
271066	REC271066	310	478736	REC478736	368	832598	TEN00707	452
271067	REC271067	310	478736	RM478736	368	832669	REC832669	420-421
271214	REC271214	307	479956	REC479956	319-320-321-322-324	832675	REC832675	420-421-425
271215	REC271215	307	508932	REC982209	390	832820	REC832820	435-441
271217	REC271217	307	508935	REC89825302	390	832831	REC832831	449
271218	REC271218	307	802399	REC859120	296	832846	REC832846	441
271237	REC271237	307	803374	REC859015	298	832934	CM832934	458
271975	REC271975	332-335	803723	REC840785	343	832934	TEN00709	452
272002	REC272002	304	803762	REC803762	450	833070	REC859151	290
272004	REC272004	304	804186	REC875512	447	833188	REC833188	314
272040	REC272040	304	804190	REC804190	447	833274	REC833274	290
272043	REC272043	304	804693	REC840785	343	833323	REC21134777	371
272059	REC272059	304	804695	REC804695	350	833415	JOH10-35157-1	339
275052	REC875722	305	806256	REC831009	344	833415	JOH10-35157-3	339
275331	REC275331	306	806341	REC806341	317	833453	REC859137	290
275334	REC275334	305	806624	REC806624	437	833522	JOH10-35157-3	339
275336	REC275336	305	807036	REC807036	352	833598	REC859145	297
275337	REC275337	306	807078	REC807078	385	833637	REC838637	314
275338	REC275338	306	807368	JOH10-35157-1	339	833878	REC833878	343
275340	REC275340	305	807368	JOH10-35157-3	339	833883	JOH10-35157-1	339
275341	REC275341	305	813316	RM813316	467	833883	JOH10-35157-3	339
275342	REC275342	305	813317	RM813317	467	833913	TEN00719	454
275344	REC275344	305	813967	REC804190	437	833915	TEN00720	454
275346	REC275346	305	813967	REC813967	437-447	833996	REC833996	350
275350	REC275350	307	814301	REC814301	441	833997	REC840384	343
275369	REC275369	306	814332	REC814332	435-442	834337	REC834337	366-414
275370	REC275370	306	814356	REC814356	435-441	834337	RM834337	366
275595	REC275595	304	814388	REC814388	435-441	834438	HGE5387	325
275751	REC275751	304	814388	REC814388	435-441	834438	HOT20930	325
352835	CM852835	478	814390	REC814390	435-441	834751	REC834751	319-321-449
388587	RM3885870	478	814396	REC814396	435-442	834871	REC834871	317
418262	REC1378864	289	814419	REC814419	435-441	834893	PH140-0013	399
418411	REC418411	339-351	814611	RM814611	467	834975	REC834975	389
418412	REC418412	351	814612	RM814612	467	835096	FEL17930	279-280
418423	REC1218630	314	814615	RM814615	467	835121	PH140-0013	399
418432	REC3517857	362-367	814616	RM814616	467	835177	REC876305	353
418432	RM3517857	362-367	814626	RM814626	467	835304	REC391-5090	389-390
418445	REC418445	331-351	814627	RM814627	467	835308	REC8M6001217	389-390

R.O./OEM	REF	PAG	R.O./OEM	REF	PAG	R.O./OEM	REF	PAG
835417	REC27-33918	355	851407	REC851407	417-427-429-431-432-434-447	854986	RM854986	467
835440	REC35-06003	362	851430	REC851430	408-437	854987	SOL8812-150-15	466
835440	RM835440-9	362	851452	REC832846	435	854987	SOL8812-158-15	466
835550	REC855694	450	851983	TEN00706	452	854987	SOL8842-156-15	466
835576	REC35-53336	362	852018	CM852018	458	854988	SOL8812-148-17	466
835581	REC835581	355	852018	CM852018A	458	854988	SOL8812-155-17	466
835702	REC835702	389	852018	TEN00710	452	854988	SOL8842-156-17	466
835704	REC8M6001249	389	852018	TEN00711	452	854989	SOL8812-145-19	466
835705	REC8M6001219	389	852019	TEN00736	452	854989	SOL8812-153-19	466
835779	REC35-06007	362	852206	REC3858457	442	854989	SOL8842-156-19	466
835804	HOT20931	325	852212	REC852212	417-427-429-431-432-434	854990	SOL8812-143-21	466
835874	CEF500120T	345	852565	PH375-0028	405	854990	SOL8841-156-23	466
835874	REC10615K	345	852705	REC852705	421-425	854992	RM854992	467
835874	SHE10615K	345	852835	CM852835	437-456-478	854993	RM854993	467
835998	REC1463-9382	395	852835	CM852835A	456-478	854994	RM854994	467
838066	REC838066	296	852835	TEN00708	452	854996	SOL8831-150-15	466
838127	REC859134	290	852839	REC852839	409	854997	RM854997	467
838522	JOH10-24130-3	339	852868	REC852868	437-447	854997	SOL8831-150-17	466
838628	REC3582432	291	852904	RM852904	426-427	854998	RM854998	467
838638	REC838638	314	852928	PH200-T027	406	854998	SOL8831-150-19	466
838652	REC838652	296	852939	REC3819905	404	854999	RM854999	467
838653	REC838653	296	852984	RM852984-4	408-437	854999	SOL8831-150-21	466
838654	REC838654	297	853048	REC853048	435-437	855105	CM855105	456
838660	REC876099	305	853175	REC853175	435	855297	REC855297	371
838695	REC3581528	380	853223	REC876279	435-441	855326	PH140-0013	399
838697	REC861260	380	853255	REC75832T	420	855380	HGE7037	326
838929	CM838929	458-471-472-474	853439	RM872612-7	407	855384	HOT20935	327
838929	CM838929A	458	853484	REC853484	421	855387	HGE5387	317-325
838929	TEN00714	454	853502	REC3819905	404	855387	HOT20930	317-325
838929	TEN00715	454	853542	REC853542	420	855389	REC855389	450
839195	REC839195	408-435	853655	RM872614	442	855409	RM855409	336
839253	REC839253	420-421-425	853670	REC839253	444	855410	RM855410	336
839423	REC839423	426-442	853759	REC83759	408-437	855423	RM855423	336
839534	REC839534	426-442	853760	REC853760	408-437	855428	RM855428	460
840074	REC840074	384	853807	REC853808	432	855433	RM855433	336
840076	JOH10-35157-1	339	853808	REC853808	417-429-432-434-447	855473	RM856239	460
840115	REC840115	296	853846	REC3855650	411	855506	REC855506	460-463
840270	REC3809167	290	853868	REC853868	417-420-421-423-425-447	855507	REC855507	461
840328	REC859094	290	853871	REC853808	447	855513	REC855513	288
840384	REC840384	343	854031	REC832846	435	855517	JOH10-32621-2	337
840405	REC859093	291	854031	REC854031	441	855578	JOH10-32621-2	337
840440	REC859043	296	854040	REC854040	426-428	855617	REC855617	451
840461	REC859044	296	854045	REC854045	426-442-467	855648	REC855648	450
840557	JOH10-24707-01	338	854047	REC854047	426	855686	RACPF5510	360
840569	REC840569	290	854057	RM872614	442	855686	REC855686-2	362
840572	REC859042	296	854077	REC854047	442	855694	RM855694	450
840648	REC840648	300	854100	RM854100	435	855728	REC855728	343
840690	RM840690	328-331	854133	RM854133	435	855729	FEL17980	278-280
840785	REC840785	343	854256	REC21533394	379	855791	RM855791	336
840902	REC840902	298-331	854346	PH200-T017	406	855889	REC823426A1	378
841031	REC27-8079821	377	854531	PH200-T064-1B	407	855926	HOT20931	325
841054	REC982230	361	854541	REC854541	426	855952	REC982230	361
841066	PH140-0004	398	854555	CEF501002	449	855967	REC855967	288-317
841161	REC841161	371	854555	RM876632	449	856004	REC856004	355
841177	REC841177	404	854610	RM872612-7	407	856028	REC856028	317
841178	BS2141	405	854661	RM854661	421	856034	FEL17420	278-321
841243	REC841243	389	854666	RM872614	442	856034	REC27-33395	321
841244	REC12532	389	854704	RM854704	408-437	856036	REC856036	319
841262	REC841262	388	854705	RM854705	408-437	856042	REC856042	319
841263	REC841263	388	854765	REC2192426	468	856044	REC856044	288-317
841293	REC841294	378	854766	BVA0990730A	468	856083	RM856083	336
841377	PH140-0022	400	854766	REC21924263	468	856100	RM856100	336
841600	REC855297	371	854767	BVA0990740A	468	856116	FEL17410	288-319
841676	HGE6894	325	854767	REC21924264	468	856116	REC27-99757	319
841693	REC841693	343	854768	BVA0990750A	468	856137	HGE6894	325
841750	REC35-06004	362-476	854768	REC21924265	468	856239	RM856239	460
841750	RM841750	362	854769	BVA0990760A	468	856355	REC3819905	404
841812	RM841812	403	854769	REC21924266	468	856365	FEL17320	278-280
841895	REC855389	450	854770	BVA0990770A	468	856472	REC856472	378
841926	REC392-9086T	389	854770	REC21924267	468	856513	REC3860703	338
841994	REC841994	378	854771	REC21924268	468	856575	FEL17040	282
842080	REC842080	315	854772	REC21924269	468	856609	PH600-0002	333
842275	JOH10-22335-3	340	854772	REC21924269	468	856616	FEL17340	283
842280	REC842280	368-472-473-474	854773	REC21924270	468	856626	FEL17935	284-285
842843	JOH10-24061-3	339	854814	REC21924262	468	856659	MP39200	401
842913	REC842913	331	854814	REC21924262	468	856883	HOT20931	321-325
842990	REC859038	299	854814	REC21924262	468	856889	FEL17985	284
842993	RM21325765	330	854815	REC21924263	468	856891	HOT20935	321-327
842993	RM21325765	331	854816	BVB0990630A	468	856894	HGE6894	319-325
843217	HGE5261	328	854816	REC21924264	468	856895	HGE7037	326
843228	RM843228	328-449	854817	BVB0990640A	468	857037	HGE7037	319-326
843323	REC843323	450	854817	REC21924265	468	857177	FEL17310	275
844971	JOH10-24130-3	339	854818	BVB0990650A	468	857618	REC857618	319-321
845189	REC3829313	340	854818	REC21924266	468	857621	REC857621	286
845261	HGE5261	328-331	854819	BVB0990660A	468	857624	RM857624	409
845261	SED3091000	329-331	854820	REC21924267	468	857633	RACSS3228UL	361
845294	REC845294	380	854820	BVB0990670A	468	858065	JOH10-35157-1	339
845528	HGE528	328-331	854821	REC21924268	468	858150	JOH10-24268-4	339
846037	REC846037	380	854932	CEF501001	449-478	858464	REC858464	447
846354	REC3829311	339	854935	REC854935	319-321	858467	REC858467	339-344
846762	REC22637542	404	854977	RM854977	467	858469	JOH10-24277-3	339
847573	REC847573	358	854978	RM854978	467	858488	REC858488	368-471-472
847605	REC847605	385	854979	RM854979	467	858503	REC859155	292
847741	REC847741	367-472-473-474	854981	SOL8832-150-15	466	858729	CEF500530	449
847741	RM847741	367	854982	RM854982	467	858729	RM858955	449
848275	REC865428	381	854982	SOL8832-150-17	466	858955	CEF500530	449
848276	REC865428	381	854983	RM854983	467	858955	RM858955	449
849270	REC876069	369	854983	SOL8832-150-19	466	858979	REC858979	358
850834	PH200-T028	406	854983	SOL8832-150-19	466	858992	REC3583786	292
850888	REC850888	426-441-442-467	854984	RM854984	467	858993	REC3582432	291
850889	REC850889	426-442-467	854984	SOL8832-150-21	466	859002	REC859002	331



R.O./OEM	REF	PAG	R.O./OEM	REF	PAG	R.O./OEM	REF	PAG
859011	REC859011	331	861826	REC861473	367	875388	REC876417	294
859015	REC859015	298	861826	RM861473	367	875400	REC876342	289
859032	REC861251	300	861858	RM861858	314	875402	REC876337	287
859038	REC859038	299	861859	RM861859	314	875403	REC876306	289
859039	REC859039	299	861860	REC861860	313	875407	REC875407	378
859042	REC859042	296	861860	REC861860	314	875421	REC875387	302
859043	REC859043	296	861906	MAR906	329-331	875438	REC876416	295
859044	REC859044	296	861906	RM861906	329-331	875439	REC875439	301
859093	REC859093	291	861906	SED3090900	330-331	875483	RM875483	308
859094	REC859094	290	861907	REC861907	331-329	875485	RM875485	308
859107	REC859107	298	861911	RM861911	354-474	875491	RM875491	310
859120	REC859120	296	861954	RM861954	306	875492	RM875492	310
859134	REC859134	290	861955	RM861955	306	875498	REC875498	306
859135	REC859135	290	863169	REC863169	385	875499	REC875499	306
859136	REC3809167	290	863344	REC876185	369	875500	REC876377	292
859136	REC3809167	290	863437	REC3837935	340	875501	REC876378	300
859137	REC859137	290	863750	REC864315	366	875502	REC876377	292
859140	REC859140	298	863946	REC863946	387	875503	REC876389	300
859145	REC859145	297	864315	REC864315	366	875504	REC876377	292
859150	REC859150	291	864878	REC865428	381	875505	REC876388	300
859151	REC859151	290	865295	REC3838207	342	875508	REC876379	293
859152	REC859152	291	865334	REC865428	381	875509	REC876314	301
859155	REC859155	292	865428	REC865428	381	875512	REC875512	447
859194	REC859194	298	865545	SED3091400	330	875533	REC876337	287
859428	REC859428	371	866396	REC3829313	340	875541	REC875541	305
859494	REC859494	374	866653	REC866653	465-472-473	875543	REC875621	286
859593	PH140-0023	398	866835	REC866835	385	875550	REC875550	304
859618	PH375-0013	405	866836	REC866836	385	875551	REC875551	304
859642	REC859642	306	867975	REC876099	305	875553	REC876376	293
859647	REC859647	291	870690	REC870690	388	875554	REC876384	301
859650	RM861858	314	872001	SOL8811-150-15	466	875561	REC876341	292
859656	RM861859	314	872001	SOL8811-158-15	466	875562	REC876381	300
859726	REC861603	300	872001	SOL8841-156-15	466	875567	REC876417	294
859746	REC861476	367	872002	SOL8811-148-17	466	875569	REC876358	286
859746	RM861476	367	872002	SOL8811-155-17	466	875570	REC876359	287
859791	REC859791	308	872002	SOL8841-156-17	466	875571	REC15-404	397
859807	REC859807	311	872003	SOL8811-145-19	466	875572	REC876380	293
859834	RM859834	298-331-381	872003	SOL8811-153-19	466	875573	REC876383	301
859836	REC859836	329-331	872003	SOL8841-156-19	466	875574	REC875574	348
859844	REC3582500	372	872004	SOL8811-143-21	466	875575	CEF500170CG	344-345-347
859865	MAR345	329	872004	SOL8812-153-21	466	875575	JOH09-801B	344-345-347-471-475
859945	REC859945	308	872004	SOL8842-156-21	466			337-343-344-345-347-348
859949	REC859949	311	872026	REC21389074	449	875575	REC875575	304
859963	MAR963	328-331	872027	RM872027	421	875579	REC875579	304
859963	SED3091100	329-331	872066	REC872066	383	875580	REC875580	353-471-475
860320	REC3582310	372	872082	REC872082	426-442	875584	REC875584	348
860339	REC22637542	404	872096	REC872096	435-436-441	875587	REC876300	287
860388	REC860388	465-472	872139	CM872139	457-478	875588	REC876393	289
860396	CEF500531	449	872139	CM872139A	457-478	875633	REC3582596	294
860396	RM860396	328-329-449	872139	TEN00724	452	875634	REC876349	302
860409	RM860409	358	872215	RM872215	412	875651	REC275751	304
860433	RM860993	387	872241	PH140-0023	398	875652	REC875722	305
860434	RM860993	387	872334	REC872334	437	875655	REC875541	305
860435	RM860993	387	872338	REC872338	437	875662	REC3582596	294
860629	REC3583115	339	872362	REC872362	408	875676	REC875676	305
860631	REC21880386	336	872363	RM872363	408	875678	REC876301	287
860656	SED3091200	329	872549	RM872549	427-442	875697	CEF500145T	346
860684	REC861250	300	872612	RM872612-7	407	875697	JOH09-814B	346
860685	REC861251	300	872614	RM872614	427-442	875697	REC875697	346
860749	REC3809167	290	872616	RM881797	387	875698	REC875698	348
860786	RM3581724	387	872722	REC872722	437	875707	REC875722	305
860827	REC3583115	339	872752	REC872752	435-436-437-441	875715	REC876382	300
860916	REC3581528	380	872753	REC872753	436	875720	REC876391	415-443
860918	REC861260	380	872756	REC872756	436	875722	REC875722	305
860920	REC860920	358	872793	CM872793	456	875741	REC875741	443
860993	RM860993	387	872793	CM872793A	456	875747	CEF501002	449
861009	JOH10-24707-01	338	872793	TEN00717	452	875747	RM875747	310
861014	RAC2010TM-OR	363	872812	REC872812	408-437	875747	RM876632	449
861019	REC861019	460	872837	RM3860881	407	875748	RM875748	310
861103	REC861103	374	872845	REC872845	437	875750	RM875750	308
861250	REC861250	300	872872	REC3858458	442	875751	RM875751	308
861251	REC861251	300	872891	REC3858457	442	875752	RM875752	308
861255	REC861255	375	872986	REC872986	436	875753	RM875753	308
861260	REC861260	380	873066	REC873066	383	875756	REC875756	348
861263	REC861263	358	873183	RM873183	435	875757	REC875757	301
861289	MAR289	328-331	873228	REC873228	409	875759	REC877373	348
861289	SED3091200	329-331	873229	REC873229	409	875769	REC875769	349
861407	REC3802092	381	873395	CM873395	457	875773	RM875773	308
861431	REC861431	451	873395	CM873395A	457	875774	RM875774	308
861473	REC861473	367	873395	TEN00722	452	875781	REC876080	353
861473	RM861473	367	873411	CM873411	458	875783	REC875783	354-471
861474	REC3581621	366	873412	CM873412	458			354-471-472-473-474
861474	RM3581621	366	873413	CM828140	458	875785	REC875785	353
861475	REC3581621	366	873531	REC22314183	411	875788	REC3831426	353
861475	RM3581621	367	873534	REC873534	436	875790	REC876080	353
861476	REC861476	367	873740	REC22637542	404	875791	REC875791	353
861476	RM861476	367	873765	REC21400091	404	875794	REC876305	353
861477	REC861477	365	873770	PH300-0008-D	401	875795	RM875795	354-474
861477	RM861477	365	873770	PH300-0027-OE	403	875796	REC875796	354-453-471
861563	REC861563	461-463	874109	REC3588916	384	875805	CMV-17	426-457
861564	REC861564	463-465-471-472	874385	REC3827444	398	875805	CMV-17A	457
861574	MAR345	329	874501	REC21423488	399	875805	TEN00702	451
861603	REC861603	300	874502	REC874502	401	875807	JOH09-806B	344
861657	RM861657	358	875031	REC3582597	294	875809	CMV-16	456
861688	REC861688	375	875303	REC875303	311	875809	TEN00701	451
861698	REC861698	315	875306	REC875306	308	875810	CMV-15	456-478
861699	REC861699	315	875307	REC875307	308	875810	TEN00700	451
861700	REC8631652	313-315	875320	REC875541	305	875812	CM875812	456
861725	REC861725	375	875331	REC875331	311	875812	CM875812A	456
861812	REC861812	342	875334	REC875334	308	875812	TEN00705	451
861822	REC861822	299	875383	REC875383	348	875814	CEF500145T	346
861823	REC861823	303	875387	REC875387	302			



R.O./OEM	REF	PAG	R.O./OEM	REF	PAG	R.O./OEM	REF	PAG
1161995	REC1161995	481	3581460	RM3581460	465-471	3587079	REC3587079	406
1218630	REC1218630	316	3581528	REC3581528	380	3587159	SED3091600	330
1266286	REC3517857	362-367	3581536	REC3581536	375	3587216	REC874502	401
1266286	RM3517857	362-367	3581558	REC3583115	339	3587410	REC859836	329
1266796	REC1378879	288	3581621	REC3581621	366	3587508	REC3587508	332-335
1275148	REC271975	332	3581621	RM3581621	366	3587597	REC3587597	353-477
1276425	REC1276425	303	3581696	REC3581696	375			
1306169	REC1306169	388	3581714	REC22185027	305	3587651	RM3587651	318-320-322-323-324-438
1306341	REC1306341	316	3581724	RM3581724	387	3587858	RM3885250	460
1306630	REC1306630	313-314	3581760	RAC2010PM-OR	363	3587859	RM3885250	460
1317761	REC1317761	316	3581774	PH150-0007	398	3587927	REC3843100	385
1317792	REC1317792	314	3581774	PH150-0007-OE	398	3588305	REC22171036	461
1317793	REC1317793	314	3581868	REC21165389	292	3588378	REC3840335	365
1324492	REC1324492	403	3581869	REC21165390	292	3588378	RM3840335	365
1324750	REC1324750	384	3581889	REC3581889	315	3588432	REC21371112	294
1326239	REC1317761	316	3582310	REC3582310	372	3588433	REC21371111	295
1326785	REC1378646	286	3582324	REC3582324	460-463	3588434	REC3588434	301
1332644	REC1378646	286	3582358	REC21646645	368	3588435	RM3588435	299-382
1336385	REC1336385	385	3582358	RM3582357	368	3588437	RM3588437	355
1336753	REC1378870	288	3582432	REC3582432	291	3588475	CEF500114T	346-347-475
1336763	REC1336763	316	3582433	REC3583786	292	3588475	JAB17937-0001-P	346-341-347
1357775	REC1674083	343	3582434	REC3582435	294	3588475	REC17937-0001	346
1378646	REC1378646	286	3582435	REC3582435	294	3588491	REC21423488	399
1378853	REC1378853	288	3582436	REC3583787	295	3588683	RM3588684	326
1378854	REC1378854	288	3582437	REC3583788	295	3588684	RM3588684	318-326
1378864	REC1378864	289	3582458	REC3582500	372	3588745	CM3588745	458-478-479
1378870	REC1378870	288	3582500	REC3582500	372	3588745	CM3588745A	458
1378879	REC1378879	288-317	3582561	REC3582561	315	3588746	CM3588746	458-478
1378909	REC1378909	287	3582563	REC3582563	299	3588746	CM3588746A	458
1378911	REC1378911	288	3582595	REC3582595	298	3588746	TEN00733	453
1378913	REC1378913	288	3582596	REC3582596	294	3588748	CM3588746A	478
1378914	REC1378914	289	3582597	REC3582597	294	3588748	TEN00733	453
1378960	REC3582608	314	3582606	REC3582606	315	3588750	TEN00733	453
1504952	REC1504952	403	3582608	REC3582608	315	3588753	CEF500538K	448-478
1542052	REC1542052	297	3582609	REC3582609	315	3588770	CM3588745A	478
1542123	REC1542123	298	3582639	REC3582639	358	3588865	RM3588865	372
1542170	REC3582310	372	3582692	REC22171036	461	3588879	REC803356	303
1542177	REC1542123	298	3582694	REC22774756	461	3588916	REC3588916	384
1542187	REC1542187	355	3582725	REC3582725	297	3589104	REC22905155	342
1542219	REC859039	299	3582732	REC3582732	368	3589316	REC3840525	367
1542247	REC861251	300	3582732	RM3582732	368	3589316	RM3840525	367
1542263	REC968955	316	3582748	REC3582748	303	3589322	REC3589322	292-293
1542287	RM1542287	296	3582851	REC860971	303	3589522	REC3589522	423
1542318	REC1542318	303	3582887	REC3582887	415	3589524	REC3589524	423
1542389	REC1542389	314	3582888	REC3582888	415	3589544	MAR345	329
1542472	REC1542472	314	3582986	REC21457172	336	3589554	REC3883845	295
1544109	REC859150	291	3583006	REC3801225	380	3589875	TEN00733BIS	478
1544119	REC1544119	296	3583073	REC3583073	375	3589907	REC21380890	341
1544124	REC861250	300	3583089	REC3583089	340	3593573	CEF500177GT	346
1545198	REC1545198	314-315	3583115	REC3583115	339	3593573	JAB17018-0001	346
1665251	REC21192875	368	3583322	REC3583322	415	3593573	REC3593573	346
1674083	REC1674083	343	3583336	REC3583336	297	3593654	REC3593654	340
1674084	REC1674083	343	3583338	REC21457172	336	3593655	REC3593655	340
2170344	CEF500105T	345-347	3583443	REC3583443	366	3593656	CEF500116GX	346
2170344	JOH09-1029B	345-347-472	3583443	RM3583443	366	3593656	JOH09-1026B	346
2170344	REC21730344	345	3583546	REC3583546	297	3593656	REC2141637	340
2194262	REC2194262	468	3583555	REC21323043	398	3593656	REC3593659	346
3183211	REC21310068	315	3583654	REC21702999	369	3593663	REC3593663	415-446
3183211	REC3183211	315	3583665	REC22774756	461	3593951	REC3593951	413
3287677	REC3287677	395	3583693	RM3583693	307	3593951	REC3593951	413
3514432	REC3514432	313	3583700	REC3583700	303	3593981	CM3593881	414-458-478
3517857	REC3517857	362-367	3583729	REC3583729	465-475	3593981	CM3593881A	458
3517857	RM3517857	362-367	3583780	REC3583780	355	3594159	REC21655254	336
3517860	REC3517893	313-314	3583786	REC3583786	292	3594161	REC21655254	336
3545696	REC3545696	384	3583787	REC3583787	295	3594444	RM21608511	373
3547560	REC271975	332	3583788	REC3583788	295	3594509	CEF500537K	447
3555413	CEF500380	345	3583840	REC3583840	336	3594509	REC3808898	447-478
3578536	REC11010	342	3583856	REC3884701	329	3594989	REC3594989	411
3580026	REC3580026	303	3583856	MAR701	329	3599981	TEN00738	453
3580064	REC3593654	340	3583856	HGE1640	329	3660566	PH140-0017-D	399
3580096	REC861477	365	3583856	SED3091500	330	3779955	REC22187386	407
3580096	RM861477	365	3583915	REC21450768	329	3801138	REC3801138	382
3580100	REC3580100	372	3584062	REC3584062	341-349	3801173	REC3801173	382
3580222	REC3593655	340	3584063	REC21380890	341	3801204	REC3848965	399
3580223	REC3593655	340	3584086	RM3584086	464-474	3801270	REC3801270	381
3580227	REC3580227	299	3584126	REC21132189	372	3801271	REC3801271	381
3580303	RM3580303	314	3584127	REC3584127	405	3801296	REC21423488	399
3580304	RM3580304	314	3584145	REC3584145	369	3801351	REC21323043	398
3580305	REC22393048	313-314	3584145	RM3584145	369-475	3801387	REC3801387	381
3580306	REC22393048	313	3584167	REC3584167	448	3801404	REC3801404	334-335
3580309	REC3580309	291	3584168	REC3584168	448	3801636	REC3801404	334
3580337	RM3580337	306	3584202	REC3584202	291	3802020	REC846037	380
3580338	RM3580338	306	3584442	TEN00728BIS	453-478	3802033	REC845294	380
3580365	RM3580365	354-474	3586461	CM3854130	478	3802061	REC861260	380
3580478	RM21186281	314	3586461	CM3854130A	478	3802070	REC861260	380
3580482	REC3584202	291	3586494	CEF500100GX	344-346-347	3802082	REC3581528	380
3580509	REC3580509	369-474	3586494	JOH09-806B	344-346-347-471-474	3802092	REC3802092	381
3580514	REC3580514	355	3586494	REC3586494	343-344-346-347	3802105	REC3802105	381
3580546	RM3580546	306	3586722	REC3817861	305	3802112	REC3802105	381
3580547	RM3580547	306	3586758	REC876775	307	3802125	REC3802125	380
3580586	REC3580586	303	3586765	PH200-T017	406	3802145	REC3801270	381
3580742	REC3583786	292	3586765	PH200-T027	406	3802149	REC3802149	382
3580835	REC3580835	464	3586857	REC22582994	307	3802150	REC3802150	382
3580900	REC3593654	340	3586871	RM3586871	309	3802151	REC3802151	382
3580910	REC3593655	340	3586873	RM3586873	309	3802152	REC3802152	382
3580920	REC3593655	340	3586875	RM3586875	309	3802167	REC3801271	381
3580944	REC3593654	340	3586877	RM3586877	309	3803577	REC3884858	401
3580945	REC3593655	340	3586877	RM3586877	309	3803645	REC8676498	401
3581062	RM3581724	387	3586960	REC3586960	303	3803648	REC21423488	399
3581114	RM3581114	449	3587046	REC21655254	336	3803650	REC874502	401
3581115	RM3581115	449	3587071	REC3587071	401	3803846	REC874502	401
3581150	REC3802092	381	3587072	RM3587072	401	3803855	REC21423488	399

R.O./OEM	REF	PAG	R.O./OEM	REF	PAG	R.O./OEM	REF	PAG
3803903	REC3819662	402	3829668	SED3091400	330	3850942	REC3850942	428
3803904	REC3840888	398	3830004	REC876069	369	3850984	REC22188	443
3803911	REC874502	401	3830459	CEF500163G	346	3850984	REC22189	443
3803929	REC21323043	398	3830459	JAB17938-0001-P	342-346	3850984	REC380842	428-443
3803938	REC21423488	399	3830988	SED3091400	330-331	3851218	REC3862228	362
3803940	REC3884858	401	3831236	REC3831236	367	3851218	RM3862228	362
3804296	REC21423488	399	3831424	REC3831424	354-471-472	3851227	BAOMC-20-3862603	326
3807400	TEN00744	453	3831425	REC3831425	354-471-472-473-474	3851334	RM3851334	427
3807613	RM3807613	417-420-421-423-424-425	3831426	REC3831426	353-354	3851482	RM3851482	469
3808228	REC3808228	438-439	3836314	REC21380886	341	3851483	RM3851483	469
3808516	REC892617	385	3837935	REC3837935	340	3851623	SHEG9901	337
3808536	CEF500538K	448	3838207	REC3838207	342	3851982	SHEG9903	337
3808602	REC3808602	290	3838288	REC3838288	341-349	3852002	REC13-35048	320-322-323-324
3808605	REC861473	367-474	3838852	RAC2040TM-OR	363	3852020	REC126870	428-442
3808605	RM861473	367	3838854	RAC2020TM-OR	363	3852030	REC35-06003	362
3808616	REC3808616	366-384	3838952	RM3838952	368	3852030	RM835440-9	362
3808796	REC21250645	384	3839110	REC3839110	354-472-473	3852044	REC25-33145	438
3808797	REC3808797	384	3839469	RM3817517	366	3852045	REC3852045	423-424-425-439-479
3808898	CEF500537K	447	3840050	REC21389074	449	3852056	REC3852056	428-442-479
3808898	REC3808898	419-447	3840181	REC874502	401	3852058	REC21-20553	320-322-323-324
3809070	REC21457172	336	3840335	REC3840335	365	3852071	REC0307239	355
3809071	REC21457172	336	3840335	RM3840335	365	3852096	REC27-8146801	335-355
3809093	REC21655254	336	3840525	REC3840525	367	3852106	REC3852106	464
3809097	REC21655254	336	3840525	RM3840525	367	3852111	REC27-33918	335-355
3809167	REC3809167	290	3840761	REC3840761	439	3852135	REC22-428611	320-322-323-324
3809445	REC3809445	481	3840816	REC3840816	355-474-475	3852142	REC3852142	318
3809465	REC21280913	461	3840842	REC3840842	291	3852165	REC3852165	410
3809559	REC21721548	409	3840843	REC21192973	291	3852169	REC331188	438
3809560	REC21721550	409	3840859	REC3840859	299	3852193	REC92995-08600	424
3809625	RM3809625	464-474	3840888	REC3840888	398	3852215	REC3852215	384
3809647	REC3809647	290	3841011	REC3841011	439	3852217	REC300-00879	395
3809657	REC3809657	297	3841013	REC3841013	439	3852224	REC40155	362
3809662	RM3809662	314	3841080	REC861477	365	3852268	RM3852268	426-427-428-429-431-432-433-434
3809721	REC3809721	366	3841080	RM861477	365	3852272	REC3852272	417-423-424
3812109	REC3812109	291	3841366	RM3841366	403	3852279	REC3852279	423
3812131	REC3812131	297	3841427	CM3841427	478	3852288	RM3852288	334-335
3812159	RM3812159	464-474	3841481	CEF500514K	438-448	3852289	RM3852289	334-335
3812199	REC3812199	291	3841481	REC3841481	438-448	3852295	REC3852295	417-423-424-425
3812240	REC3812240	337-338-342	3841481	RM22197130	448	3852296	REC3852296	417-421-423
3812269	RM3858128	412	3841482	RM21277185	448	3852315	REC3852315	428-429-431
3812357	REC3812357	414	3841510	SED3091600	330	3852317	REC3852317	423
3812472	RM3812472	306	3841697	CEF500106GT	346	3852329	REC22336734	417
3812474	RM3812474	306	3841697	JOH09-1028B	346	3852336	REC3852106	464
3812518	REC21212800	338	3841697	REC3841697	346	3852338	MAR499	325
3812519	REC21212799	338	3841840	REC21484383	411	3852347	BAOMC1-3852347	323-325
3812520	RM21255090	338	3842015	RM3842015	354-474	3852348	GDY15382	464
3812522	RM21212798	337	3842442	REC3887328	384	3852350	REC3852350	428-442
3812693	REC21214599	337	3842607	CM3883728	433	3852352	CEF501010	449
3812695	REC21214601	338	3842607	CM3883728A	433	3852352	REC3852352	438-449
3812696	RM21214595	337	3842853	REC3842853	320-322-328	3852362	RM3861459	326
3812697	RM21214596	338	3843100	REC3843100	385	3852374	HOT20986	325
3817033	REC3817033	307	3843136	REC3843136	419	3852374	MAR501	325
3817034	REC22185027	305	3843751	REC3843751	383	3852390	RM3852390	417-420-421-423-424-425
3817328	REC3817328	372	3847481	REC22171036	461	3852398	SHEG9901	337
3817466	SOL8611-150-15	466	3847482	REC3847482	461	3852399	SHEG9903	337
3817466	SOL8613-148-15	466	3847499	MAR499	320-325	3852412	REC35-06003	362
3817466	SOL8641-155-15	466	3847501	HOT20986	322-325	3852412	RM835440-9	362
3817467	SOL8611-148-17	466	3847501	MAR501	322-325	3852413	REC3862228	362
3817467	SOL8613-145-17	466	3847644	REC3847644	362-477	3852413	RM3862228	362
3817467	SOL8651-148-17	466	3847644	RM3847644	362	3852418	RM3852418	423
3817468	SOL8611-145-19	466	3848896	REC21280913	461	3852454	REC3852454	423
3817468	SOL8613-143-19	466	3848965	REC3848965	399	3852455	FEL17460	277-281-323
3817468	SOL8651-148-19	466	3849006	REC3849006	419	3852455	REC3852455	323
3817469	SOL8611-143-21	466	3849411	REC3863007	411	3852464	REC3852464	464
3817469	SOL8613-140-21	466	3849413	REC3863007	411	3852467	REC3852467	320-322
3817469	SOL8651-145-21	466	3850064	REC1674083	343	3852468	FEL17420	322
3817470	SOL8611-142-23	466	3850245	RM3850245	376	3852468	REC27-33395	322
3817470	SOL8642-145-23	466	3850268	GDY15356	464	3852472	FEL17440	284-285-324
3817471	SOL8612-150-15	466	3850288	MP426434	376	3852472	REC27-46820	324
3817471	SOL8614-148-15	466	3850305	SOL8651-140-24	466	3852476	REC3852476	323
3817471	SOL8642-155-15	466	3850315	SOL8652-140-24	466	3852477	REC27-34897	333-335
3817472	SOL8612-148-17	466	3850357	REC22024631	387	3852504	RM3852504	464
3817472	SOL8614-145-17	466	3850360	REC3850360	335-353	3852516	RM3852516	423
3817472	SOL8652-148-17	466	3850396	REC3850396	387	3852523	REC332583	438
3817473	SOL8612-145-19	466	3850397	REC3850397	383	3852535	REC3852535	438
3817473	SOL8614-143-19	466	3850426	CEF500528	438-448	3852537	REC309731	438
3817473	SOL8652-148-19	466	3850426	REC3850426	438-448-478-479	3852538	REC3852538	318-319-320-321-322-324
3817517	RM3817517	366	3850430	RM3850430	464-476	3852548	REC3852548	438
3817687	REC3817687	337-342	3850491	RM3888323	413	3852550	REC3852550	438
3817688	REC3817688	338-342	3850492	RM3888323	413	3852551	REC3852551	438-439
3817861	REC3817861	305	3850495	REC3850495	318	3852555	REC3852555	411-439
3818541	REC21702999	369	3850525	PH140-0015	399	3852558	REC3852558	439
3818912	REC3818912	334	3850559	REC3850559	363	3852560	REC3852560	423-439-479
3819016	REC21450768	329	3850559	RM3850559	363-476	3852565	REC25-30613	417-423
3819485	REC21380886	341	3850594	REC3850594	422-446	3852568	REC3852568	423
3819662	REC3819662	402	3850683	RM3885196	407	3852573	RM3852573	410
3819905	REC3819905	404	3850740	REC22-73379	320-322-323-324	3852602	REC3852602	323
3825038	REC3825038	369-472	3850794	RM3858873	328	3852604	GS38320	318-320-322-323-324
3825133	REC21492771	376	3850796	RM3858873	328	3852607	RM3852607	464-476
3825133	RM21492771	366	3850799	BAOMC20-910380	318-326	3852648	RM3852648	410-423-424-438-439
3825493	REC3837935	340	3850802	REC13980	318	3852655	FEL17971	276
3826841	SED3091400	330	3850809	REC3858261	373	3852687	FEL17931	278-280
3827069	REC3827069	363-367	3850812	REC3850812	423-424	3852693	FEL17900	275
3827069	RM3827069	367	3850813	REC393831	423	3852696	REC3852696	320322-323-324-448
3827167	RM3838952	368	3850814	REC3850814	423	3852824	REC27-56880	333-335
3827273	REC3827273	465	3850815	REC59830A7	423	3852830	REC3852830	320-322-323-324
3827444	REC3827444	398	3850852	REC3850852	414-417-420-421-423-424-425	3852865	REC3852865	417-428
3828838	RM3817517	366	3850853	REC183247	417			
3829311	REC3829311	339	3850861	REC3850861	360			
3829312	REC3829312	340	3850913	REC3855271	327			
3829313	REC3829313	340						

R.O./OEM	REF	PAG	R.O./OEM	REF	PAG	R.O./OEM	REF	PAG
3852866	REC3852866	428-429-431-432-433-434	3854261	REC3854261	390-392	3857450	MAR870	325
3852958	RM3852958	410	3854286	CEF500103T	345-347	3857470	REC21840806	407
3852959	REC3852959	428-429-431	3854286	REC3854286	345-347	3857470	RM3857470	410
3852970	CM3852970	457	3854286	SH09959K	345-347-475-476	3857471	RM3857471	407
3852970	CM3852970A	457	3854299	FEL17010	275	3857487	REC853678T	386
3852970	TEN00727	452	3854300	FEL17920	276	3857489	REC3587079	406
3853155	REC10-37612	323	3854311	REC3854311	390-392	3857521	REC3857521	410
3853226	REC70817B	313	3854331	REC3854331	392	3857522	REC3857522	410
3853256	FEL17304	274-318	3854331	REC3854331	390	3857523	REC3857523	409-410
3853256	REC27-815528	318	3854346	MP426422	376	3857524	REC3857524	409-410
3853283	REC3853283	318-377	3854427	REC3855269	327	3857532	REC8M0068784	384
3853336	FEL17000	274	3854428	REC3855271	327	3857533	REC3857533	404
3853341	REC3853341	279-281	3854466	HOT20909	327	3857588	RM3857588	410
3853342	REC27-33956	333-335	3854466	MAR061	327	3857650	REC3857650	372
3853361	REC27-49110	333-335	3854480	REC3854480	417-423-424	3857656	MAR499	325
3853373	REC16-70236	318	3854512	REC8M0077616	386	3857662	REC27-807473A1	278-280
3853378	REC3853378	318	3854527	REC805223T	383	3857675	REC3857675	428
3853380	FEL17020	277	3854539	REC22-67892A05	415	3857678	MAR499	325
3853380	FEL17030	279	3854539	REC22-67892A05	423-424-428-432-433	3857684	BAOMC-20-3862603	326
3853397	REC3853397	318	3854548	REC3854548	390-392	3857696	REC3843751	383
3853404	REC46335	318-320-322-323	3854549	REC3854549	392	3857723	HOT20986	325
3853412	FEL17410	275-288-320	3854595	REC3854595	428-429-431	3857723	MAR501	325
3853412	REC27-99757	320	3854601	REC3854601	431	3857747	PH140-0017-D	399
3853423	REC3853423	410-423-438	3854624	REC3854624	429-431	3857794	SHEG9903	337
3853424	RM3853424	410-423	3854625	REC3854625	429-431	3857798	BAOMC-20-3862603	326
3853430	REC3853430	318	3854643	RM3854643	464-476	3857810	BAOMC-20-3862603	326
3853431	REC3853431	318	3854750	PH140-0020	400	3857813	PH300-0015	402
3853434	REC3853434	323	3854809	PH300-0010	402	3857835	REC3857835	464
3853510	FEL17986	284-285	3854842	REC3594989	411	3857927	REC3850861	360
3853511	FEL17042	282	3854858	REC8M0073435	371	3857954	REC3857954	337-338-342
3853513	FEL17937	284-285	3854874	RM3854874	320-327	3857982	RM21610333	376
3853521	REC26-75988	313	3854905	REC3854905	387	3857986	REC3858261	373
3853536	REC3853536	464	3854942	FEL17921	276	3858051	RM3858051	428
3853567	REC3855269	327	3854956	REC26-34217	313	3858069	REC3587079	406
3853568	REC3855271	327	3855017	REC3855017	378-379	3858071	PH200-T007	406
3853587	FEL17048	284	3855079	SHEG9903	337	3858077	REC3858077	407
3853608	RM3853608	449	3855081	REC3855081	423-424-425-428-432-433-434-479	3858139	REC3860384	448
3853628	REC3853628	318	3855182	REC3855182	374	3858212	REC3858212	411
3853787	REC3853787	383	3855184	REC805226A1	386	3858229	RM21214596	338
3853796	PH600-0006	333-335	3855185	REC3855184	383	3858261	REC3858261	373
3853799	REC3853799	353-477	3855194	REC3855194	383	3858303	REC3863090	446
3853801	REC3853801	389	3855194	REC3855194	383	3858331	MP426422	376
3853804	REC3853804	413	3855269	REC3855269	323-327	3858333	MP426434	376
3853815	REC392-9766	389	3855270	HOT20909	327	3858340	PH600-0004	332-335
3853825	RM3853825	409	3855270	MAR061	327	3858399	CM3858399	459-478
3853839	PH375-0027	405	3855271	REC3855271	323-327	3858399	CM3858399A	459-478
3853850	PH600-0005	332-333-335	3855275	REC3855275	428-445	3858399	TEN00728	453
3853854	REC3853854	409-410	3855276	REC3855276	371	3858457	REC3858457	427-442
3853855	REC3853855	409-410	3855279	MP426574	376	3858458	REC3858458	427
3853856	REC3853856	409-410	3855281	RM3858873	328	3858458	REC3858458	442
3853857	REC3853857	409-410	3855296	REC803148	386	3858462	REC3858462	464
3853915	RM3858873	328	3855409	REC9139284	286	3858631	RM3858631	438
3853917	REC3858437	450	3855411	CM3855411	428-429-431-457-478	3858714	REC3858714	373
3853934	REC3853934	428-433	3855411	CM3855411A	428-429-431-457	3858736	REC3858736	360
3853945	PH200-T023	406	3855411	TEN00726	452	3858809	REC3858081	403
3853962	REC3853962	450	3855535	REC3863007	411	3858847	SHEG9901	337
3853982	PH140-0015	399	3855650	REC3855650	411	3858870	HGE8870	318-325
3853983	REC3853983	353-476-477	3855778	SH09910	337	3858870	MAR870	318-325
3854001	REC3854001	392-394	3855805	MP425024	330	3858871	HGE8870	325
3854002	REC3854002	392-395	3855806	MP425036	330	3858871	MAR870	325
3854003	REC3854003	392-394	3855807	REC824326002	275	3858873	RM3858873	320-322-323-324-328-438
3854017	PH600-0004	332	3855907	MP426766	376	3858941	REC3858941	374
3854018	REC3854018	377-378	3855983	REC10-37612	323-324	3858969	REC885176	374
3854019	REC984491	362	3855991	PH600-0002	333-335	3858975	REC898253T22	391-393
3854020	REC3854020	376-378-379	3856002	REC3856002	428-429-431-445	3858977	REC898253013	390-391-393
3854045	HGE8870	325	3856002	REC3856002	428-429-431-445	3858979	REC864297T01	385
3854045	MAR870	325	3856003	PH140-0020	400	3858984	REC3858984	394
3854053	REC3854053	371	3856069	REC3858458	442	3858987	REC8M0087834	387
3854077	REC3854077	394	3856070	REC3858457	442	3859019	REC898253T23	390-393
3854084	REC84-817376T01	392	3856138	FEL17982	278-280	3859020	REC8M0087834	387
3854086	RM21610333	376	3856176	REC3857176	423	3859050	REC3859050	417-443
3854095	FEL17342	283-285	3856366	RM3856366	469	3859066	MP426422	376
3854100	MP425113	330	3856367	RM3856367	469	3859078	REC3859078	395
3854105	REC3854105	376-378-379	3856443	FEL17903	275	3859082	REC3859082	386
3854106	REC1396-4656	378-379	3856444	HOT20909	327	3860079	REC3860079	461-462
3854107	REC1396-5238	376-378-379	3856444	MAR061	327	3860087	RM3860087	464-476
3854118	PH600-0002	333	3856502	RM3856502	417-420-421-423-425	3860092	REC3860092	464-477
3854127	CEF500514K	448	3856597	REC21389074	449	3860093	RM3860093	464
3854127	REC3841481	448	3856617	BAOMC-20-3862603	326	3860171	PH300-0014	402
3854127	RM22197130	448	3856662	BAOMC-20-3862603	326	3860183	REC3860183	425
3854130	CM3854130	438-457-478	3856839	REC3856844	411	3860210	RM21608511	373
3854130	CM3854130A	438-457	3856844	REC3856844	411	3860230	RM3860230	420
3854130	TEN00718	452	3856961	REC3856961	353	3860230	RM3860230	421
3854138	REC3854138	404	3857079	REC3857079	406	3860230	RM3860230	425
3854158	REC3854158	383	3857140	REC3857140	436	3860232	REC3860232	421-425
3854159	REC3854159	383	3857148	RM3857148	421	3860252	RM3860252	428-429-431
3854161	REC3854161	395	3857166	REC15-604	397	3860384	REC3860384	448-478
3854164	BS2142	405	3857166	REC15-801	397	3860703	REC3860703	338
3854186	BS2143	405	3857166	REC15-806	397	3860726	RM3858128	412
3854190	PH140-0004	398	3857176	REC3857176	420-421-423-425	3860764	PH140-0017-HT	399
3854194	PH375-0009	398-405	3857202	REC21214599	337	3860769	PH300-0010	402
3854217	REC3854217	391	3857265	PH200-T017	406	3860795	REC21214601	338
3854218	REC3854218	391	3857307	REC3858458	442	3860798	PH300-0017	402
3854247	REC3854247	408	3857325	REC3850861	360	3860808	REC3860808	436
3854249	REC31-66668A1	415-417-428-429-431-432-433-434	3857391	RM3857391	334-335	3860842	REC3860842	423
3854249	REC3854249	433	3857402	HOT20909	327	3860842	RM3860842	417-423-424
3854250	REC31-86748A1	428-429-432-433-434	3857402	MAR061	327	3860871	REC3884974	413
3854254	BAOMC29-910303	335	3857431	RM3857431	410	3860879	REC3857079	406
3854260	REC3854260	390-392	3857449	REC805222A1	391-392	3860881	RM3860881	407
			3857450	HGE8870	325	3860883	RM3858128	412

R.O./OEM	REF	PAG	R.O./OEM	REF	PAG	R.O./OEM	REF	PAG
3861010	RM3885250	460	3884972	RECV11010	342	21131568	RM21212801	337
3861027	PH200-T017	406	3884974	REC3884974	413	21132189	REC21132189	372
3861034	RM21132390	464	3885196	RM3885196	407	21132437	RM21610333	376
3861068	REC22256171	447	3885250	RM3885250	460	21132674	RM21132674	413-478
3861267	REC3861267	395	3885317	PH140-0017-D	399	21132989	RM21132989	309
3861295	REC15-808	397	3885323	RM3586883	311	21132990	RM21132990	311
3861323	REC3859082	386	3885324	RM3885324	311	21134777	REC21134777	371
3861341	PH600-0003	333-335	3885441	REC21196919	368	21139810	REC21139810	365
3861355	RM21608511	373	3885870	RM3885870	448	21139810	RM21139810	365-475
3861375	REC3861375	403	3886431	REC3886431	291	21140344	REC3809721	366
3861376	REC3861376	404	3886591	REC21171277	369	21141341	REC21379288	368
3861417	RM21214595	337	3886847	RM21277185	448	21141637	REC21141637	340
3861459	RM3861459	324-326	3886848	REC22905150	342	21146097	REC22663814	412
3861570	REC883166A2	407	3887328	REC3887328	384	21160912	REC2160912	464
3861575	PH200-T012	406	3887373	REC3887373	413	21165389	REC21165389	292
3861634	CM3861634	417-457	3887761	CEF500162G	346	21165390	REC21165390	292
3861634	CM3861634A	417-457	3887761	JOH09-821B	346	21171277	REC21171277	369
3861634	TEN00742	453	3887761	REC3887761	346	21172053	REC21280913	461
3861636	CM3861636	457	3887960	REC22121309	407	21190094	MAR906	329
3861636	CM3861636A	457	3888301	REC21840806	407	21190094	RM861906	329
3861636	TEN00743	453	3888305	CM3888305	456	21190094	SED309090	330
3861837	REC3594989	411	3888305	CM3888305A	415-456-478	21190113	REC861477	365
3861842	HOT20909	327	3888305	TEN00734	453	21190113	RM861477	365
3861842	MAR061	327	3888306	TEN00734	453	21192875	REC21192875	368
3861985	REC3861985	393-395	3888323	RM3888323	413	21192973	REC21192973	291
3862014	REC3854549	390	3888324	REC15-405	392-397	21192974	REC21192974	291
3862168	CEF500538K	448	3888325	REC15-601	392-397	21196919	REC21196919	368
3862198	HOT20909	327	3888326	REC15-804	392-397	21212798	RM21212798	337
3862198	MAR061	327	3888327	REC15-606	393-397	21212799	REC21212799	338
3862210	RM3858128	412	3888328	REC15-815	393-397	21212800	REC21212800	338
3862228	REC3862228	362	3888460	REC22377272	366	21212801	RM21212801	337
3862228	RM3862228	362	3888555	REC3888555	439	21213660	CEF500107T	345-346-347
3862308	PH140-0020-D	400-405	3888555	RM3888555	438	21213660	JOH09-1027B	345-346-337-338-339-340-347-347-471-474-475-477
3862387	REC3862387	419	3888813	CM38883728	478	21213660	REC21213660	337-338-344-345-346-347
3862482	REC21214599	337	3888813	CM38883728A	432-434-457-478	21213664	REC21213664	337-338-345-347
3862484	REC21214601	338	3888814	CM38883728	432-434-457-478	21214595	RM21214595	337
3862485	RM21214595	337	3888814	TEN00733BIS	453	21214596	RM21214596	338
3862487	RM21214596	338	3888814	TEN00735	454	21214596	REC21214599	337
3862500	REC3862500	320-322-324-383	3888816	CM3841427A	439-457-478	21214596	REC21214596	338
3862513	RM3858128	412	3888817	CM3841427	439-457-478	21214599	RM21214599	337
3862523	REC3862523	334-335	3888817	TEN00737	453	21214601	REC21214601	338
3862612	PH300-0017	402	3888821	REC23022	433-445	21219693	REC3583840	336
3862612	PH300-0036	402	3888822	REC23020	432-445	21219723	REC21219723	341-349
3862613	PH300-0037	402	3888916	CEF500536K	448-479	21226191	RM21226191	309
3862627	RM3862627	320-322-324-327	3888916	REC3888916	439-448-478	21228429	RM21228429	292
3862665	PH300-0037	402	3888917	REC3888917	424-446	21250645	REC21250645	384
3862867	REC3862867	419-424	3889148	REC21457172	336	21252967	RM21252967	311
3862904	RM3862627	327	3889484	REC21171277	369	21255090	RM21255090	338
3862904	MAR627	327	3889517	REC21192974	291	21258482	RM3851482	469
3862985	PH140-0022-CCW	400	3889782	REC3889782	424	21258483	RM3851483	469
3863007	REC3863007	411	3889784	REC3889784	432-433	21258484	RM3851484	469
3863061	HOT20909	320-322-323-324-327	3889786	REC3889786	432-433-434	21258484	RM3851484	469
3863061	MAR061	320-322-323-324-327	3889788	REC3889788	439	21258484	RM3856365	469
3863071	BAOMC-20-3862603	318-326	3889954	REC22187385	407	21258486	RM3856366	469
3863083	REC3863083	419-447	3889964	REC3889964	320-322-324-327	21258486	RM3856367	469
3863084	REC3863084	419	4100276	TEN00732	453	21277185	RM21277185	448-478
3863085	REC3863085	419-424	4785974	REC127695-35150	367	21280913	REC21280913	461
3863090	REC3863090	428-433-446	4785974	RM4785974	367	21301848	RM21301848	306
3863129	REC3594989	411	6210419	RM6210419	354-471	21302969	REC21302969	398
3863130	REC3863130	386-393	6600756	RECV11010	342	21307714	RM21186282	314
3863189	RM3863189	320-322-327	6842160	REC6842160	303	21310068	REC21310068	315
3863191	REC3863191	320-322-323-324	6842273	REC6842273	303	21310068	REC3183211	315
3863193	CM3855411A	478	6854250	REC31-86748A1	417	21314684	RM21314684	464-474
3863347	RM21548739	412	8149182	REC8149182	355-475	21319767	RM21319767	308
3863405	RM21548739	412	8520219	CM852019	458	21323043	REC21323043	398
3863406	RM21548739	412	8599252	PH150-0007	398	21325765	RM21325765	330
3863407	RM21548739	412	8599252	PH150-0007-OE	398	21344508	REC22774756	461
3863443	GS38322	320-322-323-324	8631533	REC8631533	386	21363429	REC21363429	480
3863450	REC3863450	318-320-322-323-324-449	8631650	RM8631650	315	21363430	REC21363430	480
3863450	RM3863450	322	8631651	RM8631651	315	21368879	REC21368879	369
3875050	REC840902	298	8631652	REC8631652	313-315	21371111	REC21371111	295
3875376	REC859135	290	8642665	REC8642665	296	21371112	REC21371112	294
3875382	REC859194	298	8653103	REC8653103	384	21379102	REC21379102	340
3875384	REC840115	296	8658726	REC8658726	386	21379288	REC21379288	368
3881586	REC21171277	369	8676498	REC8676498	401	21380886	REC21380886	341
3883257	RM3883257	438-439	8683212	RM31261191	365	21380890	REC21380890	341
3883777	REC3883777	439	8692305	REC8692305	362-368-474-477	21389074	REC21389074	415-449-478
3883784	REC22171036	461	8692438	REC8692438	296	21400091	REC21400091	404
3883786	REC21280913	461	8777066	CEF500135	346	21405493	REC21405493	465
3883844	REC22034	299	8777066	JOH09-819B	346	21407026	RM21407026	465
3883845	REC3883845	295	8777066	REC21730344	346	21412639	REC21412639	355
3884010	RM3884010	315	9139282	REC9139282	286	21412646	RM21412646	355
3884015	RM3884015	315	9671587	GDY17291	465	21412647	RM21412647	355
3884352	REC3843100	385	11305263	REC21400091	404	21419374	REC21419374	341-349
3884410	REC21945911	409	20450736	REC20450736	355	21419376	REC21419376	341-349
3884512	RM21132989	309	20513285	REC20513285	315	21423488	REC21423488	399
3884515	RM21226191	309	20513343	REC21426987	386	21424345	MAR345	329-331
3884517	RM3884517	308	20532237	REC21192875	368	21426987	REC21426987	386
3884528	RM3884528	314	20739057	REC20739057	315	21436799	REC21436799	395
3884548	REC3884548	297	20821230	REC3831236	367	21450768	REC21450768	329-331
3884557	RM3884557	311	20856959	RM20856959	312	21457172	REC21457172	336
3884561	RM3884561	311	20867177	RM20867177	311	21484383	REC21484383	411-439
3884694	REC21141637	340	20867178	RM20867178	309	21492771	REC21492771	366
3884701	REC3884701	329-331	20867661	RM20867661	311	21492771	RM21492771	366
3884701	MAR701	329	20867751	RM20867751	309	21501189	REC859171	313-314
3884701	HGE1640	329	21106041	REC21379102	340	21505553	REC22663814	412
3884701	SED3091500	330-331	21112450	REC21389074	449	21533394	REC21533394	379
3884858	REC3884858	401	21114522	REC38201	320-324	21545138	RM21608511	373
3884950	PH300-0037	402	21124846	REC879194401	332-333-335	21548739	RM21548739	412
			21124849	REC21124849	385	21549542		

R.O./OEM	REF	PAG	R.O./OEM	REF	PAG	R.O./OEM	REF	PAG
21549542	RM3827069	367	22256625	RM21745117	412	13554-0001	REC13554-0001	345
21549544	REC3581621	366	22283751	REC22283751	464	27-41609	REC27-41609	377
21549544	RM3581621	366	22303438	CEF501001	415-449-478	27-60715	REC27-60715	377
21585053	REC21585053	460	22303438	CEF501011	449	27-65577	REC27-65577	377
21608511	RM21608511	373	22303438	REC875822	449	27-70142	REC27-70142	377
21610333	RM21610333	376	22314183	REC22314183	411-437	3863080	REC3863080	419-447
21610334	MP426422	376	22336734	REC22336734	419-423-424-435-	+3863081		
21610728	REC21655254	336	22352491	REC22352491	464	853807	REC853808	431
21622232	REC21622232	391-393	22377272	REC22377272	366	+853808		
21624740	REC3840335	365	22389354	REC22389354	305	+876267	REC875741	443
21624740	RM3840335	365	22393048	REC22393048	313-314	876266	REC19037	443
21632901	REC21632901	368	22430456	REC22430456	434	+876268		
21632901	RM21632901	368	22452003	RM21745117	412	RM3860881	RECKITDP	408
21640514	REC3831236	367	22452005	REC22452005	412	RM872612	RECKITDP2	408
21641712	REC21880386	336	22479638	REC22479638	480			
21646645	REC21646645	368	22479642	REC22479642	480			
21646645	RM3582357	368	22479648	REC22479648	414-480			
21652399	REC3858212	411	22479650	REC22479650	480			
21655254	REC21655254	336	22527820	REC22527820	315			
21684825	SED3091600	330-331	22574246	REC22574246	480			
21687472	REC21913334	367	22582994	REC22582994	307			
21687793	REC21687793	336-481	22612828	REC22612828	434			
21687796	REC21687796	336-481	22612828	REC22612828	445			
21700014	HGE1502	329	22637542	REC22637542	404			
21702999	REC21702999	369	22651246	CM3888305	478			
21707132	REC21707132	368	22671213	SED3091600	330			
21707132	RM477556	368	22671214	HGE1502	329			
21707133	REC478736	368	22774756	REC22774756	461			
21707133	RM478736	368	22898644	REC22898644	470			
21707134	REC21707134	367	22898645	REC22898645	470			
21707134	RM466634	367	22898646	REC22898646	470			
21711728	REC21711728	307	22898647	REC22898647	470			
21718912	REC3583443	366	22905150	REC22905150	342			
21718912	RM3583443	366	22905155	REC22905155	342			
21721548	REC21721548	409	22915955	REC22915955	304			
21721550	REC21721550	409	22948844	SED3091600	330			
21730348	CEF500177GT	346	22948847	HGE1502	329			
21730348	JAB17018-0001	346	22954700	REC22954700	465			
21730348	REC3593573	346	23059414	REC23059414	333			
21745117	RM21745117	412	23172849	CM40005875	414			
21745119	REC22452005	412	23172849	CM40005875A	414			
21752712	REC30-879194A01	438	23172849	TEN00739AL	478			
21782391	REC21646645	368	23172856	CM40005875A	478			
21782391	RM3582357	368	30637961	REC31251252	461			
21786692	REC22171036	461	30650525	REC30650525	292			
21840806	REC21840806	407	30659131	REC31419556	402			
21840807	REC22121309	407	30667118	REC31419556	402			
21849843	REC21849843	299	30677767	REC30677767	334-335			
21880386	REC21880386	336	30713459	REC30713459	296			
21910902	RM3858128	412	30729340	REC30729340	298			
21913334	REC21913334	367	30731261	REC30731261	292			
21921545	REC21921545	304	30731262	REC30731262	292			
21924262	REC21924262	468	30731263	REC30731263	292			
21924263	REC21924263	468	30731264	REC30731264	292			
21924264	REC21924264	468	30731740	RM30731740	307			
21924265	REC21924265	468	30731772	REC31359568	460			
21924266	REC21924266	468	30731809	REC30731809	464			
21924267	REC21924267	468	30750678	RM30750678	307			
21924268	REC21924268	468	30751022	REC3801404	334			
21924269	REC21924269	468	30757056	REC31251252	461			
21924270	REC21924270	468	30777600	REC31430317	296			
21945911	REC21945911	409	30782228	REC3848965	399			
21951342	CEF500121GX	346-347	30788490	REC30788490	368			
21951342	JOH09-808B	346-347-471-474	31216308	REC31216308	387			
21951342	REC3586496	338-339-346-347-	31251252	REC31251252	461			
21951342	REC3586496	348	31251996	RM9180722	311			
21951356	CEF500106GT	346	31258305	REC31359568	460			
21951356	JOH09-1028B	346	31261191	RM31261191	365			
21951356	REC3841697	346	31293668	REC3801404	334			
21951358	CEF500162G	346	31339213	REC31339213	303			
21951358	JOH09-821B	346	31359568	REC31359568	460			
21951358	REC3887761	346	31378645	REC1378645	286			
21951362	CEF500135	346	31419556	REC31419556	402			
21951362	JOH09-819B	346	31430317	REC31430317	296			
21951362	REC21730344	346	35993659	CEF500116GX	344			
21951364	CEF500145T	346	35993659	JOH09-1026B	344			
21951364	JOH09-814B	346	35993659	REC3593659	344			
21951364	REC875697	346	38622500	REC3862500	318			
21951410	REC875769	349	40005192	REC40005192	441			
21951420	REC875698	348	40005334	REC40005334	391-393			
22024631	REC22024631	387	40005775	REC40005775	303			
22030848	REC3582732	368	40005875	CM40005875	414			
22030848	RM3582732	368	40005875	CM40005875	458			
22030852	REC21632901	368	40005875	CM40005875A	414			
22030852	RM21632901	368	40005875	CM40005875A	458			
22057107	REC834337	366	40005875	TEN00739AL	453			
22057107	RM834337	366	41100098	CM41100098	458			
22063494	REC22063494	341-349	41100098	TEN00731	453			
22121309	REC22121309	407	41100276	CM41100276	458			
22171036	REC22171036	461	41100276	CM41100276P	458			
22185019	REC22185019	305	41103102	REC21687796	336-481			
22185027	REC22185027	305	41103103	REC21687793	336-481			
22187385	REC22187385	407	60112158	REC968955	317			
22187386	REC22187386	407	83857561	PH300-0014	402			
22197130	CEF500514K	448	85108974	RM85108974	387-481			
22197130	REC3841481	448-478	85122800	REC85122800	481			
22197130	RM22197130	439	898253013	REC898253013	390-391			
22197130	RM22197130	448-478	10-812509184	MPO180-000	399			
22222936	CEF500116GX	346	10-861788	REC10-861788	399-400			
22222936	JOH09-1026B	346	1275549 +					
22222936	REC3593659	346	21584008	RM3883844	299-381			
22256171	REC22256171	414-447						

## ÍNDICE

PARTES DE MOTOR	PÁG
JUNTA BASE MOTOR FEL-PRO	504
SISTEMA DE ESCAPE Y ADMISIÓN	PÁG
• DESPIECES COLECTORES Y CODOS	522
• COLECTORES ESCAPE	530
• CODOS ESCAPE	530
• JUNTAS COLECTORES Y CODOS	530
• TAPA Y JUNTAS TAPA	531
• FUELLES ESCAPE	567
SISTEMA DE REFRIGERACIÓN	PÁG
BOMBA CIRCULACIÓN DE BLOQUE	531
• BOMBAS	531
• MANGUITOS	531
• BOMBA ASPIRACIÓN AGUA MARINA	532
TERMOSTATOS	532
• KITS	532
• CUERPOS	533
• GUÍA TERMOSTATOS Y KITS	532
SISTEMA ALIMENTACIÓN Y FILTRACIÓN	PÁG
FILTROS COMBUSTIBLE	534
• FILTRO SEPARADOR DE AGUA	534
• FILTROS DECANTADORES	534
• FILTROS DE COMBUSTIBLE	534
• FILTROS ACEITE	534
• BOMBAS DE COMBUSTIBLE	533
CARBURADORES	535
• JUNTAS BASE	536
• BOYAS	538
• GUÍA KITS CARBURADOR	539
• GUÍA KITS CARBURADOR Y BOYAS	539
• KITS CARBURADOR	536
SISTEMA ELÉCTRICO	PÁG
SENSORES	540
• TEMPERATURA AIRE	540
• TEMPERATURA AGUA	540
• TEMPERATURA Y ACEITE CON ALARMA	540
• PRESIÓN DE ACEITE	540
• SENSOR TPS	540
• VACUÓMETRO. MAP	540
ENCENDIDO	540
• DISTRIBUIDORES	543
• COMPONENTES	540
• KITS DE CONVERSIÓN ELECTRÓNICO	543
• MÓDULO DE ENCENDIDO	544
• MÓDULO SISTEMA DE CAMBIO	546
• BOBINAS	544
• GUÍA DE BOBINAS	544
• BUJÍAS Y CABLES	545
• MOTORES DE ARRANQUE	546
ALTERNADORES	547
• RELÉS	548
• REGULADOR	548
• SOLENOIDES	548
TRIM	548
• MOTORES TRIM	548
• LATIGUILLOS	549
UNIDADES DE TRANSMISIÓN	PÁG
KIT CONVERSIÓN OMC-COBRA	549
PARTE INFERIOR COBRA	549
DESPIECES COLAS	550
DESPIECE TRANSON	560
KITS REPARACIÓN	562
JUNTAS	563
GUÍAS DE RETENES	564
GUÍA DE CORREAS	566
COMPONENTES COLA	567
• ACOPLAMIENTOS	567
• FUELLES CAMBIO	567
• FUELLES TRANSON	567
• FUELLES ESCAPE	567
• PIÑONES	568
• CABLE DE CAMBIO	568
• EJES DE TRANSMISIÓN	569
• CRUCETA DE CARDAN	569
• CIERRES HELICE	570
HERRAMIENTA COLA	571
ÁNODOS	571
HELICES	572
ÍNDICE REF	575

## TABLE OF CONTENTS

ENGINE PARTS	PÁG
FEL-PRO GASKETS	504
EXHAUST & INTAKE SYSTEM	PÁG
• MANIFOLDS & ELBOWS PARTS	522
• EXHAUST MANIFOLDS	530
• EXHAUST ELBOWS	530
• EXHAUST MANIFOLDS & ELBOW GASKETS	530
• CAP & CAP GASKETS	530
• EXHAUST BELLOW	567
COOLING SYSTEM	PÁG
BLOCK CIRCULATING PUMP	531
• WATER PUMP	531
• HOSES	531
• RAW MARINE WATER PUMPS	532
THERMOSTAT	532
• KITS	532
• HOUSING	533
• THERMOSTAT & KIT GUIDE	532
FUEL & FILTRATION SYSTEM	PÁG
FUEL FILTERS	534
• WATER SEPARATING FUEL FILTER	534
• COMPLET FUEL FILTER	534
• FUEL FILTERS	534
• OIL FILTER	534
• FUEL PUMP	533
CARBURETORS	535
• BASE GASKET	536
• FLOATS	538
• CARBURETOR KITS GUIDE	539
• CARBURETOR KITS & FLOATS APPLICATION	539
• CARBURETOR KITS	536
ELECTRIC SYSTEM	PÁG
SENDERS	540
• AIR TEMPERATURE	540
• WATER TEMPERATURE	540
• TEMPERATURA & OIL PRESSURE	540
• WARNING KIT	540
• OIL PRESSURE	540
• TPS	540
• MAP	540
IGNITION	540
• DISTRIBUTORS	543
• COMPONENTS	540
• ELECTRONIC CONVERSION KITS	543
• IGNITION MODULES	544
• SHIFT ASSIST MODULE	546
• COILS	544
• COIL APPLICATION	544
• SPARK PLUGS & WIRES	545
• STARTER	546
ALTERNATORS	547
• RELAY	548
• REGULADOR	548
• SOLENOID	548
TRIM	548
• TRIM MOTOR	548
• TRIM HOSES	549
UNIT DRIVES & COMPONENTS	PÁG
CONVERSION KIT OMC-COBRA	549
GEAR HOUSING ASSEMBLY COBRA	549
GEARCASE PARTS	550
TRANSON PARTS	560
REPAIR KITS	562
GASKETS	563
O-RING & OIL SEALS GUIDES	564
V-BELTS GUIDE	566
GEARHOUSING COMPONENTS	567
• COUPLERS	567
• SHIFT CABLE BELLOW	567
• TRANSON BELLOW	567
• EXHAUST BELLOW	567
• GEAR GEAR SET & CLUTCH DOGS	568
• SHIFT CABLE	568
• DRIVE SHAFT	569
• U-JOINTS	569
• PROP HARDWARE	570
STERNDRIVES TOOL	571
ANODES	571
PROPELLERS	572
REF TABLE	575

## INDICE

PARTI DEL MOTORE	PÁG
GUARNIZIONE BASE MOTORE FEL-PRO	504
SISTEMA SCARICO E ASPIRAZIONE	PÁG
• PARTE COLLETTORI E GOMITO	522
• COLLETTORE SCARICO	530
• GOMITI SCARICO	530
• GUARNIZIONE COLLETTORI E GOMITI	530
• COPERCHIO E GUARNIZIONE	530
• CUFFIE SCARICO	567
SISTEMA DI REFREDDAMENTO	PÁG
POMPE DI RICIRCOLO DI BLOCCO	531
• POMPE	531
• MANICOTTO	531
• GUIDA POMPA DI RICIRCOLO	532
TERMOSTATI	532
• KIT	532
• CORPO	533
• GUIDA TERMOSTATI E KIT	532
SISTEMA ALIMENTAZIONE E FILTRAZIONE	PÁG
FILTRI COMBUSTIBILE	534
• FILTRO SEPARATORE ACQUA-BENZINA	534
• FILTRI DECANTATORE BENZINA	534
• FILTRI BENZINA	534
• FILTRI OLIO	534
• POMPE BENZINA	533
CARBURATORE	535
• GUARNIZIONE BASE	536
• GALLEGGIANTI	538
• GUIDA KITS CARBURATORE	539
• GUIDA KIT CARBURATORE E GALLEGGIANTI	539
• KIT CARBURATORE	536
SISTEMA ELETTRICO	PÁG
SENSORI	540
• TEMPERATURA ARIA	540
• TEMPERATURA ACQUA	540
• TEMPERATURA PRESSIONE DELL'OLIO	540
• CON ALLARME	540
• PRESIONE OLIO	540
• TPS	540
• VACUOMETRO. MAP	540
ACCENSIONE	540
• SPINTEROGENI	543
• COMPONENTI	540
• KIT DI CONVERSIONE ELETTRONICO	543
• MODULI AVVIAMENTO	544
• MODULO SISTEMA CAMBIO	546
• BOBINE	544
• GUIDA BOBINE	544
• CANDELE E CAVI	545
• MOTORINO D'AVVIAMENTO	546
ALTERNATORE	547
• RELE	548
• REGULATORE	548
• SOLENOIDE	48
TRIM	548
• MOTORE TRIM	548
• TUBI TRIM	549
UNITÀ DI TRASMISSIONE	PÁG
KIT CONVERSIIONE OMC-COBRA	549
PARTE INFERIORE COBRA	549
PARTI PIEDI	550
PARTI TRANSON	560
KIT RIPARAZIONE	562
GUARNIZIONE	563
GUIDE TENUTE E PARAOLIO	564
GUIDA CINGHIE	566
COMPONENTI PIEDE	567
• PARASTRAPPI	567
• CUFFIE CAMBIO	567
• CUFFIE TRANSON	567
• CUFFIE SCARICO	567
• PIGNONI	568
• CAVO CAMBIO	568
• ASSE TRASMISSIONE	569
• CROCIERA	569
• CHIUSURA ELICA	570
ATTREZZATURA PIEDI	571
ANODI	571
ELICHE	572
INDICE REF	575







# JUNTAS PARA BASES GM Y FORD MARINE GASKETS TO GM & FORD ENGINES GUARNIZIONI PER MOTORI GM E FORD



Los Kits FEL-PRO, están diseñados y catalogados específicamente para aplicaciones marinas. Su calidad es superior a las juntas originales.  
FEL-PRO gaskets kits are designed and cataloged specifically for marine engine applications. Their quality is even better than the oem's.  
I kit di guarnizioni FEL-PRO, sono disegnati e fabbricati specificatamente per applicazioni marine. La qualità è assolutamente paragonabile a quelle originali.

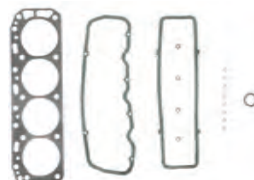





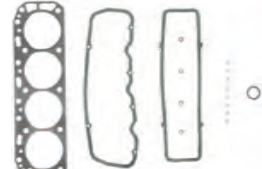
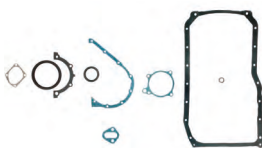

SERIE SERIAL SERIE	Descripción	Description	Descrizione
FEL17000 - FEL17099	KIT JUNTAS DE CULATA en pack individual.	CYLINDER HEAD gasket single-packed	Guarnizioni TESTATA quantità 1
FEL17100 - FEL17199	KIT DE CONVERSIÓN Todas las juntas y retenes de aceite que no se encuentran en los juegos de culata y que son necesarios para completar el acoplamiento del motor (incluye las juntas del cárter y los retenes).	CONVERSION KITS All gaskets and oil seals not found in a Head Set, that are necessary for a complete engine overhaul. This includes timing cover gaskets and seals, oil pan gaskets, and rear main bearing seals.	KIT PARTE BASSA Include tutte le guarnizioni ed i paraolio della parte bassa del motore, viene fornita anche la guarnizione della coppa dell'olio.
FEL17200 - FEL17299	KIT DE DESCARBONIZACIÓN Todas las juntas y retenes necesarios para el trabajo de las válvulas, incluyendo la junta de culata, la tapa de la válvula y juntas de colector de admisión y colector de escape. (Los kits de 4 cyl no contienen las juntas del colector de admisión/escape. Deben pedirse por separado).	HEAD SETS SERIES All gaskets and seals necessary for a valve grinding job, including cylinder head gaskets, valve cover gaskets, intake & exhaust manifold gaskets (except 4 cyl intake set), and valve stem seals.	KIT PARTE ALTA (SMERIGLIO) Include tutte le guarnizioni ed i paraolio della parte alta del motore, testate, carter distribuzione, aspirazione e scarico. (motori a 4 cyl. la guarnizione aspirazione è da ordinare separatamente).
FEL17300 - FEL17399	KIT DE COLECTOR DE ADMISIÓN Juntas de la parte de admisión del colector, retenes y juntas de la base del distribuidor.	INTAKE MANIFOLD SETS Intake manifold side gaskets, intake manifold end seals, and distributor mounting gasket.	KIT GUARNIZIONE ASPIRAZIONE Tutte le guarnizioni
FEL17400 - FEL17499	KIT DE COLECTOR DE ESCAPE (De colector a culata)	EXHAUST MANIFOLD (Manifold-to-cylinder head) gaskets.	KIT GUARNIZIONE SCARICO (dalla testata al collettore)
FEL17700 - FEL17749	KIT DE CONTRARROTACIÓN RETÉN TRASERO DEL CIGÜEÑAL Retenes traseros del cigüeñal diseñados para motores de rotación opuesta a la normal. (Retenes de rotación normal incluidos en el set de conversión)	REVERSE ROTATION REAR MAIN BEARING SEAL SETS Rear main bearing seals designed to seal a crankshaft which rotates in the opposite direction from normal (Standard rotation seal is included in conversion set)	PARAOLIO MOTORI CONTROROTANTI ALBERO MOTORE Nei motori rotazione STD il paraolio viene già incluso nel kit della parte bassa.
FEL17750 - FEL17799	KIT DE RETENES TAPA DEL CIGÜEÑAL DE CONTRARROTACIÓN Retenes de la tapa del cigüeñal diseñados para motores de rotación opuesta a la normal. (Retenes de rotación normal incluidos en el kit de conversión).	REVERSE ROTATION TIMING COVER SEAL SETS SERIES Timing cover seals designed to seal crankshaft which rotates in the opposite direction from normal (standard rotation seal is included in Conversion set and Timing cover set)	PARAOLIO CARTER DISTRIBUZIONE CONTROTOTANTI Modelli rotazione STD, incluso nella parte bassa.
FEL17900 - FEL17949	KIT DE TAPA VÁLVULA Todas las juntas de las tapas de las válvulas para sellar el motor.	VALVE COVER SET SERIES All valve cover or push rod cover gaskets (and grommets if required) required to seal one engine.	KIT COPERCHIO PUNTERIE Tutte le guarnizioni
FEL17950 - FEL17999	KIT DE CÁRTER Todas las juntas del cárter.	OIL PAN SETS SERIES All oil pan gaskets & seals, or one-piece molded rubber oil pan gasket, required to seal one engine.	GUARNIZIONE COPPA DELL'OLIO Tutte le guarnizioni

## 2.5L (100HP, 110HP, 120HP)

Ref	R.O. OEM	Descripción	Description	Descrizione
		<b>CULATA</b>	<b>CYLINDER HEAD</b>	<b>TESTATA</b>
 FEL17000	3853336 908611	JUNTA CULATA	CYLINDER HEAD	GUARNIZIONE TESTATA
 FEL17200		KIT JUNTAS SUPERIOR No incluye juntas colector escape/admisión	GASKET HEAD SET Intake & Exhaust manifold gasket not included	KIT PARTE ALTA Non include guarnizioni collettore scarico / aspirazione
		<b>INFERIOR</b>	<b>CONVERSION</b>	<b>PARTE BASSA</b>
 FEL17100		KIT JUNTAS INFERIOR Retén 2 piezas, 4 piezas junta cárter.	CONVERSION GASKET SET 2 piece rear main bearing seal & 4 piece oil pan gasket	KIT PARTE BASSA Paraolio in 2 pz, 4 pz guarnizione coppa dell'olio.
		<b>COLECTOR ADMISIÓN- ESCAPE</b>	<b>MANIFOLD INTAKE &amp; EXHAUST</b>	<b>ASPIRAZIONE - SCARICO</b>
 FEL17302		COBRA	COBRA	COBRA
 FEL17304	3853256	NO COBRA	NO COBRA	NO COBRA

Ref	R.O. OEM	Descripción	Description	Descrizione
 FEL17950	3853343	<b>CARTER</b> KIT JUNTAS CARTER Retén trasero 2 piezas, 4 piezas junta cárter.	<b>OIL PAN</b> GASKET OIL PAN SET 2 piece rear main bearing seal & 4 piece oil pan gasket	<b>COPPA DELL'OLIO</b> KIT GUARNIZIONE Paraolio posteriore in 2, guarnizione coppa in 4 pz.
 FEL17900	3852693	<b>TAPA VÁLVULAS</b> Junta tapa válvulas	<b>VALVE COVER</b> Gasket	<b>COPERCHIO VALVOLE</b> Guarnizione
 FEL17903	3856443	<b>TAPA EMPUJADORES</b> Junta tapa empujadores	<b>PUSH ROD COVER</b> Gasket push rod cover	<b>COPERCHIO ASTE PUNTERIE</b> Guarnizione coperchio aste punterie

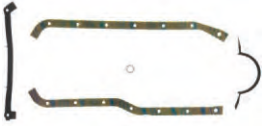
**3.0L (115 HP), 3.0L HIGH OUTPUT (130 HP), 130/3.0L (130 HP), 140/3.0L (140 HP)**

Ref	R.O. OEM	Descripción	Description	Descrizione
 FEL17000	3853336 908611	<b>CULATA</b> JUNTA CULATA	<b>CYLINDER HEAD</b> CYLINDER HEAD	<b>TESTATA</b> GUARNIZIONE TESTATA
 FEL17200		<b>KIT JUNTAS SUPERIOR</b> No incluye juntas colector escape/admisión	<b>GASKET HEAD SET</b> Intake & Exhaust manifold gasket not included	<b>KIT PARTE ALTA</b> Non include guarnizioni collettore scarico / aspirazione
 FEL17102		<b>KIT JUNTAS INFERIOR</b> Retén 1 pieza, 1 pieza junta cárter.	<b>CONVERSION GASKET SET</b> 1 piece rear main bearing seal & 1 piece oil pan gasket	<b>KIT PARTE BASSA</b> Paraolio in 1 pz, 1 pz guarnizione coppa dell'olio.
 FEL17100		<b>KIT JUNTAS INFERIOR</b> Retén 2 piezas, 4 piezas junta cárter.	<b>CONVERSION GASKET SET</b> 2 piece rear main bearing seal & 4 piece oil pan gasket	<b>KIT PARTE BASSA</b> Paraolio in 2 pz, 4 pz guarnizione coppa dell'olio.
 FEL17302		<b>COLECTOR ADMISIÓN-ESCAPE</b> COBRA con tapa de colector desmontable.	<b>MANIFOLD INTAKE &amp; EXHAUST</b> COBRA with removable end cap.	<b>ASPIRAZIONE - SCARICO</b> COBRA con coperchio collettore smontabile
 FEL17300		COBRA. Colector de una pieza. Excepto H.O.	COBRA with 1 piece manifold	COBRA. collettore in 1 pz. eccetto H.O.
 FEL17304		COBRA sólo H.O. Colector de una pieza	COBRA, H.O. only with 1 piece manifold.	COBRA solo H.O. collettore in 1 pz.
 FEL17301		Excepto COBRA.	Excl. COBRA.	Escluso COBRA
 FEL17950		<b>CARTER</b> KIT JUNTAS CARTER Retén trasero 2 piezas, 4 piezas junta cárter. Incluye junta de cárter de goma.	<b>OIL PAN</b> GASKET OIL PAN SET 2 piece rear main bearing seal & 4 piece oil pan gasket Rubber oil pan gasket incl.	<b>COPPA DELL'OLIO</b> KIT GUARNIZIONE Paraolio posteriore in 2, guarnizione coppa in 4 pz.. Guarnizione coppa dell'olio in gomma.
 FEL17900	3852693	<b>TAPA VÁLVULAS</b> Junta tapa válvulas	<b>VALVE COVER</b> Gasket	<b>COPERCHIO VALVOLE</b> Guarnizione
 FEL17903	3856443	<b>TAPA EMPUJADORES</b> Junta tapa empujadores	<b>PUSH ROD COVER</b> Gasket push rod cover	<b>COPERCHIO ASTE PUNTERIE</b> Guarnizione coperchio aste punterie

**4.3L (150, 160, 175, 180 & 205 HP)**

Ref	R.O. OEM	Descripción	Description	Descrizione
		<b>CULATA</b>	<b>CYLINDER HEAD</b>	<b>TESTATA</b>
FEL17010	3854299	JUNTA CULATA Se necesitan 2	CYLINDER HEAD 2 required	GUARNIZIONE TESTATA Ne servono 2.
FEL17210		KIT JUNTAS SUPERIOR Motor sin eje equilibrado. Incluye juntas tapa válvulas de goma y retenes.	GASKET HEAD SET Engine without balance shaft; Rubber valve cover gskts and premium valve stem seals incl.	KIT PARTE ALTA Motore senza asse bilanciato. Include guarnizione coperchio punterie e paraoli valvole.
FEL17211		KIT JUNTAS SUPERIOR Motor con eje equilibrado. Incluye juntas tapa válvulas de goma y retenes.	GASKET HEAD SET Engine with balance shaft; PermaDry molded rubber valve cover gaskets and premium valve stem seals incl.	KIT PARTE ALTA Motore con asse bilanciato. Include guarnizione coperchio punterie e paraoli valvole.
		<b>INFERIOR</b>	<b>CONVERSION</b>	<b>PARTE BASSA</b>
FEL17115		KIT JUNTAS INFERIOR Motor sin eje equilibrado con retén de una pieza y 1 pieza junta cárter de goma.	CONVERSION GASKET SET Engine without balance shaft with one-piece rear main bearing seal & 1 piece oil pan gasket	KIT PARTE BASSA Motore senza asse bilanciato. Paraolio post in 1 pz e guarnizione coppa in 1 pz.
FEL17110		KIT JUNTAS INFERIOR Motor sin eje equilibrado con retén de 2 piezas y 4 piezas junta cárter	CONVERSION GASKET SET Engine without balance shaft with 2 piece rear main bearing seal & 4 piece oil pan gasket;	KIT PARTE BASSA Motore senza asse bilanciato. Paraolio post in 2 pz e guarnizione coppa in 4 pz.
FEL17116		KIT JUNTAS INFERIOR Motor con eje equilibrado con retén de 1 pieza y 1 pieza junta cárter de goma.	CONVERSION GASKET SET Engine without balance shaft with 1 piece rear main bearing seal & 1 piece oil pan gasket; rubber oil pan gasket incl.	KIT PARTE BASSA Motore con asse bilanciato. Paraolio post in 1 pz e guarnizione coppa in 1 pz.
		<b>COLECTOR ADMISIÓN- ESCAPE</b>	<b>MANIFOLD INTAKE &amp; EXHAUST</b>	<b>ASPIRAZIONE - SCARICO</b>
FEL17310	857177	Kit Junta Admisión	Intake Gasket Set	Kit guarnizioni aspirazione
FEL17410	3853412	Kit Junta Escape	Exhaust Gasket Set	Kit guarnizioni scarico
		<b>CARTER</b>	<b>OIL PAN</b>	<b>COPPA DELL'OLIO</b>
FEL17971	3852655	1 pieza junta cárter de goma.	1 piece oil pan gasket; Rubber oil pan gasket incl.	Guarnizione coppa in 1 pz Guarnizione coppa dell'olio in gomma.
FEL17970		4 juntas carter	4 piece oil pan gasket	Guarnizione coppa in 4 pz
		<b>TAPA VÁLVULAS</b>	<b>VALVE COVER</b>	<b>COPERCHIO VALVOLE</b>
FEL17920	3854300	KIT JUNTA TAPA VÁLVULAS Motor sin eje equilibrado. Juntas de goma incluidas.	GASKET SET Engine without balance shaft, rubber gaskets included.	GUARNIZIONE COPERCHIO PUNTERIE Motore senza asse equilibrato. Guarnizione in gomma.

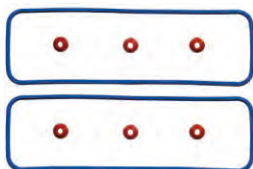

Ref	R.O. OEM	Descripción	Description	Descrizione
FEL17921	3854942	KIT JUNTA TAPA VÁLVULAS Motor con eje equilibrado. Juntas de goma incluidas.	GASKET SET Engine with balance shaft, rubber gaskets included.	GUARNIZIONE COPERCHIO PUNTERIE Motore con asse equilibrato. Guarnizione in gomma.

**5.0L (160, 170, 185 HP), 5.0L HIGH OUTPUT (175, 190, 200 HP),  
175 (175 HP), 190 (190 HP)**

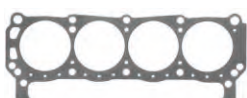

Ref	R.O. OEM	Descripción	Description	Descrizione
-----	----------	-------------	-------------	-------------

		<b>CULATA</b>	<b>CYLINDER HEAD</b>	<b>TESTATA</b>
--	--	---------------	----------------------	----------------

FEL17060		JUNTA CULATA Se necesitan 2	CYLINDER HEAD 2 required	GUARNIZIONE TESTATA Ne servono 2.
----------	--	--------------------------------	-----------------------------	--------------------------------------



FEL17261		KIT JUNTAS SUPERIOR Con tapa válvulas de aluminio. Incluye retenes de válvulas.	GASKET HEAD SET With cast aluminum valve covers. Premium valve stem seals included.	KIT PARTE ALTA Co coperchio punterie in alluminio, include paraolio valvole.
----------	--	---	--	---

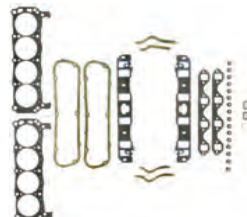

FEL17260		KIT JUNTAS SUPERIOR Incluye retenes válvulas.	GASKET HEAD SET Premium valve stem seals incl.	KIT PARTE ALTA include paraoli valvole
----------	--	--	---	---

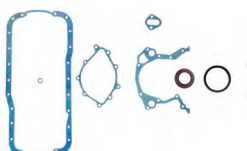

		<b>INFERIOR</b>	<b>CONVERSION</b>	<b>PARTE BASSA</b>
--	--	-----------------	-------------------	--------------------

FEL17161		KIT JUNTAS INFERIOR Retén 1 pieza, 1 pieza junta cárter de goma.	CONVERSION GASKET SET 1 piece rear main bearing seal & 1 piece oil pan gasket, rubber oil pan gasket included	KIT PARTE BASSA Paraolio in 1 pz, 1 pz guarnizione coppa dell'olio in gomma.
----------	--	--	--	---



FEL17160		KIT JUNTAS INFERIOR Retén 2 piezas, 4 piezas junta cárter	CONVERSION GASKET SET 2 piece rear main bearing seal & 4 piece oil pan gasket	KIT PARTE BASSA Paraolio in 2 pz, 4 pz guarnizione coppa dell'olio.
----------	--	---	---	---



		<b>COLECTOR ADMISIÓN- ESCAPE</b>	<b>MANIFOLD INTAKE &amp; EXHAUST</b>	<b>ASPIRAZIONE - SCARICO</b>
--	--	--------------------------------------	--	------------------------------

FEL17460		Junta Escape	Exhaust Gasket	Guarnizione scarico
----------	--	--------------	----------------	---------------------



FEL17360		Junta Admisión	Intake Gasket	Guarnizione aspirazione
----------	--	----------------	---------------	-------------------------



		<b>CARTER</b>	<b>OIL PAN</b>	<b>COPPA DELL'OLIO</b>
--	--	---------------	----------------	------------------------

FEL17995		KIT JUNTAS CARTER 4 Piezas	GASKET OIL PAN SET 4 Pieces	KIT GUARNIZIONE 4 pz
----------	--	-------------------------------	--------------------------------	-------------------------



FEL17997		JUNTA CARTER 1 pieza, incluye junta de goma	GASKET OIL PAN 1 piece oil pan gasket. Rubber gasket included.	GUARNIZIONE 1 pz. Guarnizione in gomma.
----------	--	--	--	--







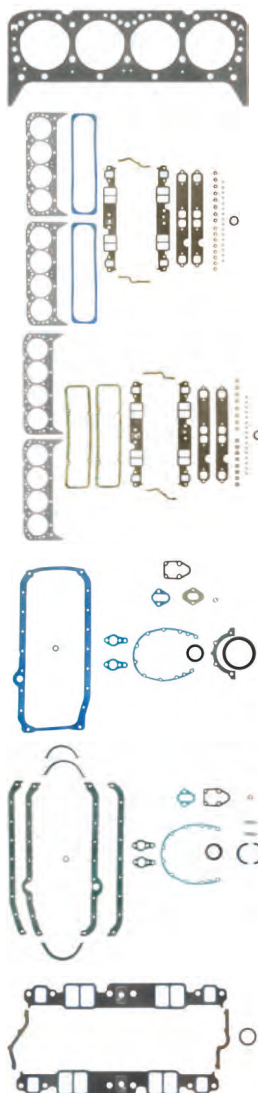



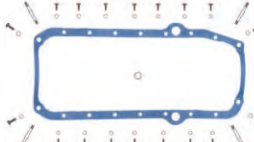

Ref	R.O. OEM	Descripción	Description	Descrizione
		<b>RETÉN TRASERO CIGÜEÑAL</b>	<b>CRANKSHAFT REAR SEAL</b>	<b>PARAOLIO POSTERIORE ALBERO MOTORE</b>
FEL17746		Retén partido. Contrarrotación. 2 piezas de goma.	Split seal. Reverse rotation rubber 2 piece.	Paraolio partido. Controrotante. 2 pz in gomma.
		<b>TAPA VÁLVULAS</b>	<b>VALVE COVER</b>	<b>COPERCHIO VALVOLE</b>
FEL17946		KIT JUNTA TAPA VÁLVULAS Con tapa válvulas de aluminio	GASKET SET With cast aluminium valve covers	GUARNIZIONE COPERCHIO PUNTERIE Con coperchio valvole in alluminio.
FEL17945		KIT JUNTA TAPA VÁLVULAS Con tapa válvulas de acero	GASKET SET With cast steel valve covers	GUARNIZIONE COPERCHIO PUNTERIE Con coperchio valvole in acciaio.
		<b>TAPA DISTRIBUCIÓN</b>	<b>TIMING COVER</b>	<b>COPERCHIO CARTER DISTRIBUZIONE</b>
FEL17995		RETÉN ACEITE Retén contrarrotación tapa distribución	OIL SEAL Rev. rotation timing cover seal	PARAOLIO paraolio contrarrotazione

**5.0L 305 V8 (185, 200, 225, 230 HP)**

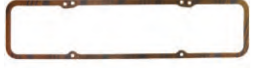

Ref	R.O. OEM	Descripción	Description	Descrizione
		<b>CULATA</b>	<b>CYLINDER HEAD</b>	<b>TESTATA</b>
FEL17020	3853380	JUNTA CULATA Se necesitan 2	CYLINDER HEAD 2 required	GUARNIZIONE TESTATA Ne servono 2.
FEL17224		KIT JUNTAS SUPERIOR Con tapa válvulas de aluminio. Tornillo centro tapa válvulas con juntas tapa válvulas de goma. Incluye retenes válvulas.	GASKET HEAD SET With center bolt desing valve covers; rubber valve cover gskts. incl; Premium valve stem seals incl.	KIT PARTE ALTA Con coperchio valvole in alluminio. Viti coperchio punterie al centro. Include paraoli valvole.
FEL17220		KIT JUNTAS SUPERIOR Tornillo en el canto tapa válvulas. Incluye retenes válvulas.	GASKET HEAD SET Rim bolt desing valvecovers; Premium valve stem seals incl.	KIT PARTE ALTA Viti coperchio punterie nel perimetro. Include paraoli valvole.
		<b>INFERIOR</b>	<b>CONVERSION</b>	<b>PARTE BASSA</b>
FEL17125		KIT JUNTAS INFERIOR Retén 1 pieza, 1 pieza junta cárter de goma.	CONVERSION GASKET SET 1 piece rear main bearing seal & 1 piece oil pan gasket, rubber oil pan gasket included	KIT PARTE BASSA Paraolio in 1 pz, 1 pz guarnizione coppa dell'olio.
FEL17120		KIT JUNTAS INFERIOR Retén 2 piezas, 4 piezas junta cárter	CONVERSION GASKET SET 2 piece rear main bearing seal & 4 piece oil pan gasket	KIT PARTE BASSA Paraolio in 2 pz, 4 pz guarnizione coppa dell'olio.
		<b>COLECTOR ADMISIÓN-ESCAPE</b>	<b>MANIFOLD INTAKE &amp; EXHAUST</b>	<b>ASPIRAZIONE - SCARICO</b>
FEL17320	856365	Junta Admisión	Intake Gasket	Guarnizione aspirazione

Ref	R.O. OEM	Descripción	Description	Descrizione
 FEL17420	856034	Junta Escape	Exhaust Gasket	Guarnizione scarico
		<b>CARTER</b>	<b>OIL PAN</b>	<b>COPPA DELL'OLIO</b>
 FEL17982	3856138	KIT JUNTAS CARTER 1 pieza junta cárter de goma.	GASKET OIL PAN SET 1 piece rubber oil pan gasket included	KIT GUARNIZIONE 1 pz guarnizione coppa dell'olio in gomma.
 FEL17983		KIT JUNTAS CARTER 1 pieza junta goma para motores con retén trasero de 2 piezas.	GASKET OIL PAN SET 1 piece rubber gasket for engines with 2 piece rear main bearing seal	KIT GUARNIZIONE 1 pz per motori con paraolio posteriore albero motore in 2 pz.
 FEL17980	855729	KIT JUNTAS CARTER Varilla aceite a babor con retén trasero de 2 piezas y junta cárter de 4 piezas.	GASKET OIL PAN SET Port dipstick with 2 piece rear main bearing seal & 4 piece oil pan gskt.	KIT GUARNIZIONE Asticella olio a babordo, motore con paraolio posteriore albero motore in 2 pz e guarnizione coppa dell'olio in 4 pz
 FEL17981		KIT JUNTAS CARTER Varilla aceite a estribor con retén trasero de 2 piezas y junta cárter de 4 piezas.	GASKET OIL PAN SET Starboard dipstick with 2 piece rear main bearing seal & 4 piece oil pan gskt.	KIT GUARNIZIONE Asticella olio a tribordo, motore con paraolio posteriore albero motore in 2 pz
		<b>RETÉN TRASERO CIGÜEÑAL</b>	<b>CRANKSHAFT REAR SEAL</b>	<b>PARAOLIO POSTERIORE ALBERO MOTORE</b>
 FEL17725		Contrarrotación, goma; 1 pieza	Rev. rotation, rubber; 1 piece	Controrotante, in 1 pz.
		<b>TAPA VÁLVULAS</b>	<b>VALVE COVER</b>	<b>COPERCHIO VALVOLE</b>
 FEL17931	3852687	KIT JUNTA TAPA VÁLVULAS Tornillo centro tapa válvulas con juntas de goma.	GASKET SET With center bolt desing valve covers; rubber gaskets incl.	GUARNIZIONE COPERCHIO PUNTERIE Coperchio con viti al centro.
 FEL17930	835096	KIT JUNTA TAPA VÁLVULAS Tornillo en el canto	GASKET SET Rim bolt desing	GUARNIZIONE COPERCHIO PUNTERIE Coperchio con viti nel perimetro
 FEL17930				
 FEL17930				
		<b>TAPA DISTRIBUCIÓN</b>	<b>TIMING COVER</b>	<b>COPERCHIO CARTER DISTRIBUZIONE</b>
 REC3853341		RETÉN ACEITE Retén contrarrotación tapa distribución	OIL SEAL Rev. rotation timing cover seal	PARAOLIO paraolio contrarrotazione

**5.0L 307 OHV V8 (210, 215, 225, 230, 235, 245 HP)**

Ref	R.O. OEM	Descripción	Description	Descrizione
		<b>CULATA</b>	<b>CYLINDER HEAD</b>	<b>TESTATA</b>
 FEL17030	3853380	JUNTA CULATA Se necesitan 2	CYLINDER HEAD 2 required	GUARNIZIONE TESTATA Ne servono 2.

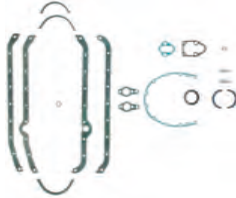
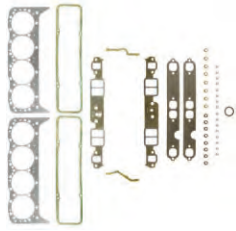



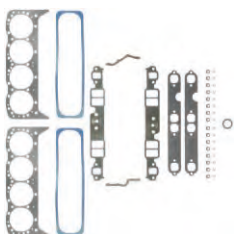
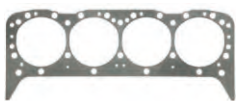

Ref	R.O. OEM	Descripción	Description	Descrizione
FEL17230		KIT JUNTAS SUPERIOR Incluye retenes válvulas.	GASKET HEAD SET Premium valve stem seals incl.	KIT PARTE ALTA Incluso tenuta valvole
		<b>INFERIOR</b>	<b>CONVERSION</b>	<b>PARTE BASSA</b>
FEL17120		KIT JUNTAS INFERIOR Retén trasero de 2 piezas y junta cárter de 4 piezas.	CONVERSION GASKET SET 2 piece rear main bearing seal & 4 piece oil pan gskt	KIT PARTE BASSA Paraolio posteriore in 2 pz e guarnizione coppa olio in 4 pz.
		<b>COLECTOR ADMISIÓN- ESCAPE</b>	<b>MANIFOLD INTAKE &amp; EXHAUST</b>	<b>ASPIRAZIONE - SCARICO</b>
FEL17320		Junta Admisión Excepto GEN+ con juntas de admisión de plástico.	Intake Gasket Excl. GEN+ eng. w/plastic intake manifold gskts.	Guarnizione aspirazione Eccetto GEN + con guarnizione aspirazione in plastica.
FEL17420		JUNTA ESCAPE	EXHAUST GASKET	GUARNIZIONE SCARICO
		<b>CARTER</b>	<b>OIL PAN</b>	<b>COPPA DELL'OLIO</b>
FEL17980	855729	KIT JUNTAS CARTER Varilla aceite a babor con retén trasero de 2 piezas y junta cárter de 4 piezas.	GASKET OIL PAN SET Port dipstick with 2 piece rear main bearing seal & 4 piece oil pan gskt.	KIT GUARNIZIONE Asticella olio a babordo, motore con paraolio posteriore albero motore in 2 pz e guarnizione in 4 pz.
		<b>RETÉN TRASERO CIGÜEÑAL</b>	<b>CRANKSHAFT REAR SEAL</b>	<b>PARAOLIO POSTERIORE ALBERO MOTORE</b>
FEL17725		Retén partido Contrarrotación, goma; 2 piezas	Split seal Rev. rotation, rubber; 2 piece	Controrotazione in 2 pz.
		<b>TAPA VÁLVULAS</b>	<b>VALVE COVER</b>	<b>COPERCHIO VALVOLE</b>
FEL17930	835096	KIT JUNTA TAPA VÁLVULAS Tornillo en el canto	GASKET SET Rim bolt desing	GUARNIZIONE COPERCHIO PUNTERIE Coperchio con viti nel perimetro
		<b>TAPA DISTRIBUCIÓN</b>	<b>TIMING COVER</b>	<b>COPERCHIO CARTER DISTRIBUZIONE</b>
REC3853341		RETÉN ACEITE Retén contrarrotación tapa distribución	OIL SEAL Rev. rotation timing cover seal	PARAOLIO paraolio contrarrotazione

**5.7L V8, 250 (215, 220, 250, 260, 270, 290 HP),  
250 KING COBRA ( 235, 270 HP), 260 (250, 260, 270, 290 HP)**

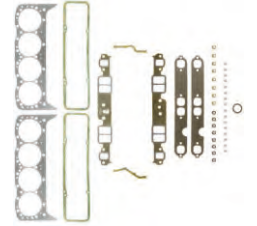
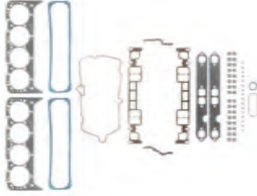
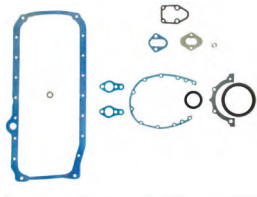
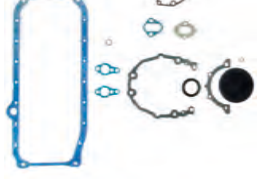
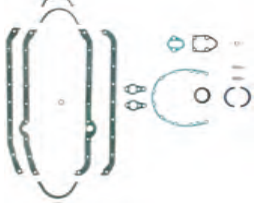
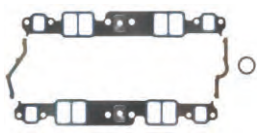
Ref	R.O. OEM	Descripción	Description	Descrizione
		<b>CULATA</b>	<b>CYLINDER HEAD</b>	<b>TESTATA</b>
FEL17030		JUNTA CULATA Se necesitan 2	CYLINDER HEAD 2 required	GUARNIZIONE TESTATA Ne servono 2.
FEL17214		KIT JUNTAS SUPERIOR Excepto GEN+ con juntas plástico colector admisión, Tornillo centro tapa válvulas con juntas tapa válvulas de goma. Retenes válvulas.	GASKET HEAD SET Exc. GEN+ eng. w/Center bolt desing valve covers; rubber valve cover gskts. incl; Premium valve stem seals incl.	KIT PARTE ALTA Escluso GEN+ con fuarnizione aspirazione in plastica, include paraoli valvole.

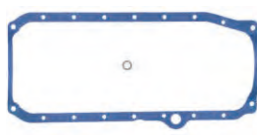
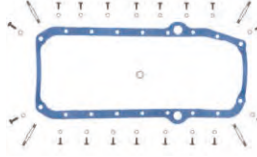

Ref	R.O. OEM	Descripción	Description	Descrizione
 FEL17230		KIT JUNTAS SUPERIOR Excepto GEN+ con juntas plástico colector admisión, Tornillo borde tapa válvulas con juntas tapa válvulas de goma. Incluye retenes válvulas.	GASKET HEAD SET Exc. GEN+ eng. w/Rim bolt desing valve covers; rubber valve cover gskts. incl; Premium valve stem seals incl.	KIT PARTE ALTA Escluso GEN+ con guarnizione aspirazione in plastica. Viteria nel perimetro del coperchi punterie include paroli valvole.
 FEL17232		KIT JUNTAS SUPERIOR GEN+ con juntas plástico colector admisión, con juntas tapa válvulas de goma. Retenes válvulas incluidos.	GASKET HEAD SET GEN+ w/ plastic intake manifold gskts. Rubber valve cover gaskets incl; Premium valve stem seals incl.	KIT PARTE ALTA GEN+ con guarnizione aspirazione in plastica. include paroli valvole.
		<b>INFERIOR</b>	<b>CONVERSION</b>	<b>PARTE BASSA</b>
 FEL17125		KIT JUNTAS INFERIOR Retén 1 pieza, 1 pieza junta cárter, incluye Junta de cárter de goma.	CONVERSION GASKET SET 1 piece rear main bearing seal & 1 piece oil pan gasket, rubber oil pan gasket included	KIT PARTE BASSA Paraolio in 1 pz, 1 pz guarnizione coppa dell'olio.
 FEL17124		KIT JUNTAS INFERIOR Con tapa de distribución de plástico, retén trasero de una pieza y junta cárter de una pieza. Junta de cárter de goma incl.	CONVERSION GASKET SET Eng. with plastic timing cover, w/one-piece rear main bearing seal & one piece oil pan gasket, rubber oil pan gskt incl.	KIT PARTE BASSA Coperchio in distribuzione in plastica, paraolio posteriore in 1 pz e guarnizione in 1 pz.
 FEL17120		KIT JUNTAS INFERIOR Retén trasero de 2 piezas y junta cárter de 4 piezas.	CONVERSION GASKET SET 2 piece rear main bearing seal & 4 piece oil pan gasket	KIT PARTE BASSA Paraolio posteriore in 2 pz e guarnizione coppa olio in 4 pz.
		<b>COLECTOR ADMISIÓN-ESCAPE</b>	<b>MANIFOLD INTAKE &amp; EXHAUST</b>	<b>ASPIRAZIONE - SCARICO</b>
 FEL17320		Junta Admisión Excepto GEN+ con juntas de admisión de plástico.	Intake Gasket Excl. GEN+ eng. w/plastic intake manifold gskts.	Guarnizione aspirazione Eccetto GEN+ con guarnizione aspirazione in plastica.
 FEL17420		JUNTA ESCAPE	EXHAUST GASKET	GUARNIZIONE SCARICO
		<b>CARTER</b>	<b>OIL PAN</b>	<b>COPPA DELL'OLIO</b>
 FEL17982	3856138	KIT JUNTAS CARTER 1 pieza junta cárter de goma.	GASKET OIL PAN SET 1 piece rubber oil pan gasket included	KIT GUARNIZIONE 1 pz guarnizione coppa dell'olio in gomma
 FEL17983		KIT JUNTAS CARTER 1 pieza junta goma para motores con retén trasero de 2 piezas.	GASKET OIL PAN SET 1 piece molded rubber gasket for engines with 2 piece rear main bearing seal	KIT GUARNIZIONE 1 pz per motori con paraolio posteriore albero motore in 2 pz.
 FEL17980	855729	KIT JUNTAS CARTER Varilla aceite a babor con retén trasero de 2 piezas y junta cárter de 4 piezas.	GASKET OIL PAN SET Port dipstick with 2 piece rear main bearing seal & 4 piece oil pan gskt.	KIT GUARNIZIONE Asticella olio a babordo, motore con paraolio posteriore albero motore in 2 pz e guarnizione.









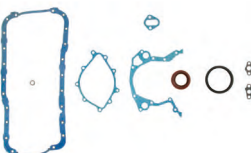
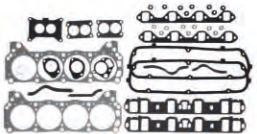
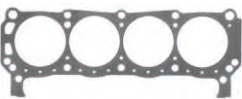

Ref	R.O. OEM	Descripción	Description	Descrizione
FEL17981		KIT JUNTAS CARTER Varilla aceite a estribor con retén trasero de 2 piezas y junta cárter de 4 piezas.	GASKET OIL PAN SET Starboard dipstick with 2 piece rear main bearing seal & 4 piece oil pan gskt.	KIT GUARNIZIONE Asticella olio a tribordo, motore con paraolio posteriori albero motore in 2 pz e guarnizione.
		<b>RETÉN TRASERO CIGÜEÑAL</b>	<b>CRANKSHAFT REAR SEAL</b>	<b>PARAOLIO POSTERIORE ALBERO MOTORE</b>
FEL17725		Contrarrotación, goma; 1 pieza	Rev. rotation, rubber; 1 piece	Controrotante, in 1 pz.
		<b>TAPA VÁLVULAS</b>	<b>VALVE COVER</b>	<b>COPERCHIO VALVOLE</b>
FEL17931	3852687	KIT JUNTA TAPA VÁLVULAS Tornillo centro tapa válvulas con juntas de goma.	GASKET SET w/Center bolt desing valve covers; rubber gaskets incl.	GUARNIZIONE COPERCHIO PUNTERIE Coperchio con viti al centro.
FEL17930	835096	KIT JUNTA TAPA VÁLVULAS Tornillo en el canto	GASKET SET Rim bolt desing	GUARNIZIONE COPERCHIO PUNTERIE Coperchio con viti nel perimetro
		<b>TAPA DISTRIBUCIÓN</b>	<b>TIMING COVER</b>	<b>COPERCHIO CARTER DISTRIBUZIONE</b>
REC3853341		RETÉN ACEITE Retén contrarrotación tapa distribución	OIL SEAL Rev. rotation timing cover seal	PARAOLIO paraolio contrarrotazione

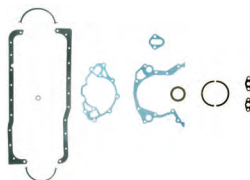
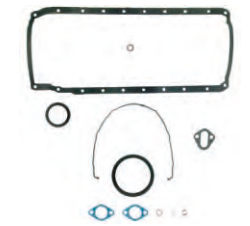
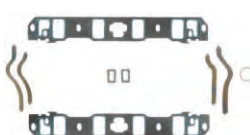
**5.8L (210, 215, 235 HP), 5.8L COBRA (240 HP), 250HP, 351 KING COBRA (260 HP)**

Ref	R.O. OEM	Descripción	Description	Descrizione
		<b>CULATA</b>	<b>CYLINDER HEAD</b>	<b>TESTATA</b>
FEL17060		JUNTA CULATA Se necesitan 2	CYLINDER HEAD 2 required	GUARNIZIONE TESTATA Ne servono 2.
FEL17261		KIT JUNTAS SUPERIOR Con tapa válvulas de aluminio. Incluye retenes de válvulas.	GASKET HEAD SET With cast aluminum valve covers. Premium valve stem seals included.	KIT PARTE ALTA Co coperchio punterie in alluminio, include paraolio valvole.
FEL17260		KIT JUNTAS SUPERIOR Incluye retenes válvulas.	GASKET HEAD SET Premium valve stem seals incl.	KIT PARTE ALTA include paraoli valvole
		<b>INFERIOR</b>	<b>CONVERSION</b>	<b>PARTE BASSA</b>
FEL17166		KIT JUNTAS INFERIOR Retén de una pieza y 1 pieza junta cárter, incluye junta de cárter de goma.	CONVERSION GASKET SET With 1 piece rear main bearing seal & 1 piece oil pan gasket; rubber oil pan gasket included	KIT PARTE BASSA Paraolio in 1 pz e guarnizione coppa dell'olio in 1 pz.

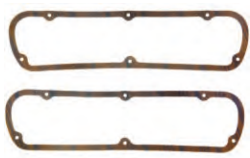

Ref	R.O. OEM	Descripción	Description	Descrizione
 FEL17165		KIT JUNTAS INFERIOR Gene V con retén trasero de una pieza y junta cárter de 1 pieza. Junta cárter de goma incluida.	CONVERSION GASKET SET Gene V w/one piece rear main bearing seal & one piece oil pan gskt. Rubber oil pan gasket incl.	KIT PARTE BASSA Gen V con paraolio posteriore di 1 pz e guarnizione coppa in 1 pz.
 FEL17146		KIT JUNTAS INFERIOR Retén de 2 piezas y 4 piezas junta cárter	CONVERSION GASKET SET With 2 piece rear main bearing seal & 4 piece oil pan gasket	KIT PARTE BASSA Paraolio in 2 pz e guarnizione coppa in 4 pz.
		<b>COLECTOR ADMISIÓN-ESCAPE</b>	<b>MANIFOLD INTAKE &amp; EXHAUST</b>	<b>ASPIRAZIONE - SCARICO</b>
 FEL17360		JUNTA ADMISIÓN	INTAKE GASKET	GUARNIZIONE ASPIRAZIONE
 FEL17460		JUNTA ESCAPE	EXHAUST GASKET	GUARNIZIONE SCARICO
		<b>CARTER</b>	<b>OIL PAN</b>	<b>COPPA DELL'OLIO</b>
 FEL17996		JUNTA 4 piezas	GASKET 4 piece oil pan gasket	GUARNIZIONE in 4 pz.
 FEL17998		1 pieza junta cárter incluye junta de goma.	With 1 piece oil pan gasket. Rubber gasket included.	Guarnizione coppa in 1 pz.
		<b>TAPA VÁLVULAS</b>	<b>VALVE COVER</b>	<b>COPERCHIO VALVOLE</b>
 FEL17946	3852687	KIT JUNTA TAPA VÁLVULAS Con tapa válvulas de aluminio.	GASKET SET W/Cast aluminum valve covers	GUARNIZIONE COPERCHIO PUNTERIE Coperchio in alluminio
 FEL17945	835096	KIT JUNTA TAPA VÁLVULAS Con tapa de válvulas de acero.	GASKET SET W/Stamped steel valve covers	GUARNIZIONE COPERCHIO PUNTERIE Coperchio in acciaio

**7.4 L, 454 (330, 335 HP GEN IV)  
HIGH OUTPUT KING COBRA (370 HP GEN IV, 330 HP GEN V),  
454 KING COBRA (275, 295, 310 HP GEN IV, 295, 310 GEN V)**

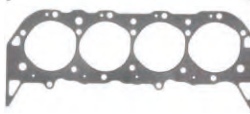
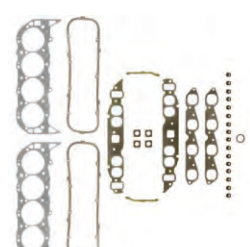
Ref	R.O. OEM	Descripción	Description	Descrizione
		<b>CULATA</b>	<b>CYLINDER HEAD</b>	<b>TESTATA</b>
 FEL17040		JUNTA CULATA Gene IV Se necesitan 2.	CYLINDER HEAD Gene IV 2 required.	GUARNIZIONE TESTATA Gene IV Ne servono 2.
 FEL17042		JUNTA CULATA Gene V & VI Se necesitan 2	CYLINDER HEAD Gene V & VI. 2 required	GUARNIZIONE TESTATA Gene V & VI. Ne servono 2.
		<b>SUPERIOR</b>	<b>HEAD SET</b>	<b>PARTE ALTA</b>
 FEL17240		KIT JUNTAS SUPERIOR Gene IV Se incluye retenes de válvula.	GASKET HEAD SET Gene IV premium valve stem seals incl.	KIT PARTE ALTA Gene IV Paraoli valvole inclusi.

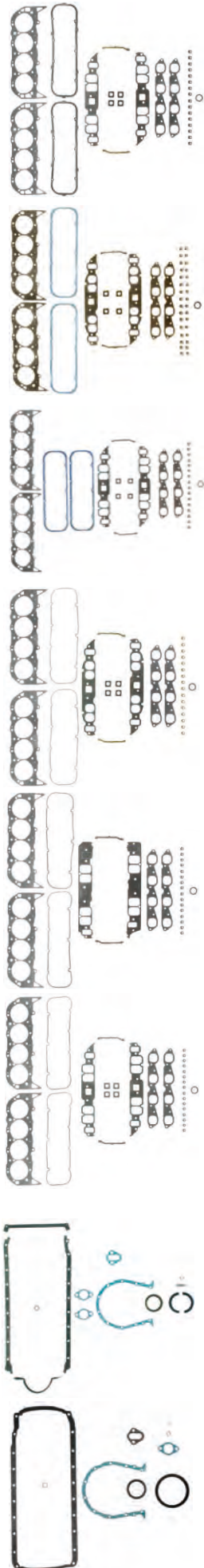

Ref	R.O. OEM	Descripción	Description	Descrizione
FEL17241		KIT JUNTAS SUPERIOR Gene IV sólo H.O. Se incluye retenes de válvula.	GASKET HEAD SET Gen IV only H.O. premium valve stem seals incl.	KIT PARTE ALTA Gen IV solo H.O. Si include paraoli valvole.
FEL17244		KIT JUNTAS SUPERIOR Gen V Excepto EFI o H.O. Juntas tapa valvula de goma. Se incluye retenes de válvula.	GASKET HEAD SET Gen V premium excl. EFI or H.O. Rubber valve cover & valve stem seals included.	KIT PARTE ALTA Gen V escluso EFI o H.O. inclusi paraoli valvole.
FEL17245		Gene V Excepto sólo H.O. Juntas tapa valvula de goma. Se incluye retenes de válvula.	Gen V premium H.O. only rubber valve cover & valve stem seals incl.	Gen V escluso H.O. inclusi paraoli valvole
FEL17242		Gene V & VI exc. H.O. o EFI Juntas tapa válvula de goma. Se incluye retenes de válvula.	Gen V & VI exc. H.O. or EFI. Rubber valve cover & premium valve stem seals included.	Gene V & VI escluso H.O. o EFI inclusi paraoli valvole
FEL17205		Gene VI sólo EFI Se incluye retenes de válvula. Juntas tapa valvula de goma.	Gen VI only EFI Rubber valve cover & premium valve stem seals included.	Gene VI solo EFI inclusi paraoli valvole
FEL17201		Gene VI sólo H.O. Se incluye retenes de válvula. Juntas tapa valvula de goma.	Gen VI only H.O. Rubber valve cover & premium valve stem seals incl.	Gene VI solo H.O. Inclusi paraoli valvole.
		<b>INFERIOR</b>	<b>CONVERSION</b>	<b>PARTE BASSA</b>
FEL17140		Gene IV con retén trasero de 2 piezas y junta cárter de 4 piezas.	Gene IV with 2 piece rear main bearing seal & 4 piece oil pan gasket.	Gene IV con paraolio posteriore in 2 pz e guarnizione coppa in 4 pz.
FEL17145		KIT JUNTAS INFERIOR Gene V con retén trasero de 1 pieza y junta cárter de 1 pieza. Junta cárter de goma incluida.	CONVERSION GASKET SET Gene V with 1 piece rear main bearing seal & 1 piece oil pan gskt. Rubber oil pan gskt. incl.	KIT PARTE BASSA Gen V con paraolio posteriore di 1 pz e guarnizione coppa in 1 pz.

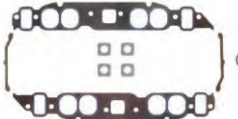
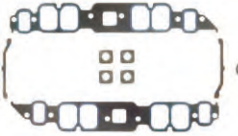
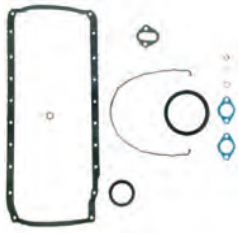

Ref	R.O OEM	Descripción	Description	Descrizione
FEL17146		KIT JUNTAS INFERIOR Gene VI con retén trasero de una pieza y junta cárter de 1 pieza. Junta cárter de goma incluida.	CONVERSION GASKET SET Gene VI with 1 piece rear main bearing seal & 1 piece oil pan gskt. Rubber oil pan gasket incl.	KIT PARTE BASSA Gen VI con paraolio posteriore in 1 pz, guarnizione coppa in 1 pz.
		<b>COLECTOR ADMISIÓN-ESCAPE</b>	<b>MANIFOLD INTAKE &amp; EXHAUST</b>	<b>ASPIRAZIONE - SCARICO</b>
FEL17341		JUNTA ADMISIÓN Gene V exc. EFI	INTAKE GASKET Gene V & exc. EFI	GUARNIZIONE ASPIRAZIONE Gen V ecc. EFI
FEL17340		Gene IV, V & VI excluido H.O. EFI	Gene IV, V & VI H.O. EFI excluded	Gene IV, V& VI esclso H.O. EFI
FEL17342		JUNTA ADMISIÓN Gene V & VI solo EFI	INTAKE GASKET Gene V & VI only EFI	GUARNIZIONE ASPIRAZIONE Gene V & VI solo EFI
FEL17440	3852472	JUNTA ESCAPE Gene IV, V & VI	EXHAUST GASKET Gene IV, V & VI	GUARNIZIONE SCARICO Gene IV V & VI
		<b>CARTER</b>	<b>OIL PAN</b>	<b>COPPA DELL'OLIO</b>
FEL17985		JUNTA CARTER GEN IV 4 pieza	GASKET OIL PAN GEN IV 4 piece	GUARNIZIONE GEN IV 4 pz,
FEL17986		JUNTA CARTER GEN V & VI, 1 pieza, incluye junta de goma	GASKET OIL PAN GEN V & VI, 1 piece oil pan gasket. rubber gasket included.	GUARNIZIONE GEN V & VI, 1 pz, guarnizione in gomma inclosa
		<b>RETÉN TRASERO CIGÜENAL</b>	<b>CRANKSHAFT REAR SEAL</b>	<b>PARAOLIO POSTERIORE ALBERO MOTORE</b>
FEL17740		Gen IV, Contrarrotación, goma; 2 piezas	Gene IV Rev. rotation, rubber; 2 piece	Gen IV, Controrotazione in 2 pz.
		<b>TAPA VÁLVULAS</b>	<b>VALVE COVER</b>	<b>COPERCHIO VALVOLE</b>
FEL17935	856626	KIT JUNTA TAPA VÁLVULAS Gen IV	GASKET SET Gen IV	GUARNIZIONE COPERCHIO PUNTERIE Gen IV
FEL17936		KIT JUNTA TAPA VÁLVULAS Gen V solo EFI Juntas de goma incluidas.	GASKET SET Gene V EFI only molded rubber gaskets incl.	GUARNIZIONE COPERCHIO PUNTERIE Gen V solo EFI Kit tenute inclusa
FEL17937	3853513	KIT JUNTA TAPA VÁLVULAS Gen V solo EFI & VI. Juntas de goma incluidas.	GASKET SET Gene V EFI only & VI Rubber gaskets incl.	GUARNIZIONE COPERCHIO PUNTERIE Gen V solo EFI & VI. Kit tenute inclusa

**7.5 L, V8, 460 KING COBRA (295, 340 HP)**

Ref	R.O. OEM	Descripción	Description	Descrizione
		<b>CULATA</b>	<b>CYLINDER HEAD</b>	<b>TESTATA</b>
FEL17068		JUNTA CULATA Se necesitan 2.	CYLINDER HEAD 2 required.	GUARNIZIONE TESTATA Ne servono 2.
FEL17268		KIT JUNTAS CULATA Se incluye retenes de válvula	CYLINDER HEAD SET Premium valve stem seals included.	KIT GUARNIZIONE TESTATA Si includono paraoli valvole
		<b>INFERIOR</b>	<b>CONVERSION</b>	<b>PARTE BASSA</b>
FEL17168		KIT JUNTAS INFERIOR Retén trasero de 2 piezas y junta cárter de 4 piezas.	CONVERSION GASKET SET 2 piece rear main bearing seal & 4 piece oil pan gasket.	KIT PARTE BASSA Paraolio posteriore in 2 pz e guarnizione coppa in 4 pz.
FEL17169		KIT JUNTAS INFERIOR con retén trasero de 2 piezas y junta cárter de 1 pieza. Junta cárter de goma incluida.	CONVERSION GASKET SET 2 piece rear main bearing seal & 1 piece oil pan gasket rubber oil pan gasket incl.	KIT PARTE BASSA paraolio posteriore di 2 pz e guarnizione coppa in 1 pz.
		<b>COLECTOR ADMISIÓN- ESCAPE</b>	<b>MANIFOLD INTAKE &amp; EXHAUST</b>	<b>ASPIRAZIONE - SCARICO</b>
FEL17368		JUNTA ADMISIÓN 4 piezas	INTAKE GASKET 4 piece	GUARNIZIONE ASPIRAZIONE 4 pz
FEL17468		JUNTA ESCAPE	EXHAUST GASKET	GUARNIZIONE SCARICO
		<b>CARTER</b>	<b>OIL PAN</b>	<b>COPPA DELL'OLIO</b>
FEL17994		JUNTA CARTER 1 pieza, incluye junta de goma	GASKET OIL PAN 1 piece oil pan gasket. Rubber gasket included.	GUARNIZIONE 1 pz, guarnizione in gomma inclosa
		<b>RETÉN TRASERO CIGÜENAL</b>	<b>CRANKSHAFT REAR SEAL</b>	<b>PARAOLIO POSTERIORE ALBERO MOTORE</b>
FEL17947		KIT JUNTAS	GASKET KIT	KIT GUARNIZIONE.

**8.2 L, 502 KING COBRA (375 HP GEN IV, 375 HP GEN V)**

Ref	R.O. OEM	Descripción	Description	Descrizione
		<b>CULATA</b>	<b>CYLINDER HEAD</b>	<b>TESTATA</b>
FEL17049		JUNTA CULATA Gene IV, V & VI super medida. Se necesitan 2.	CYLINDER HEAD Gene IV, V & VI super bore. 2 required.	GUARNIZIONE TESTATA Gene IV, V & VI grande. Ne servono 2.

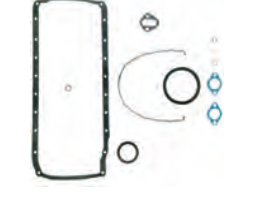
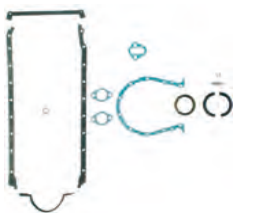
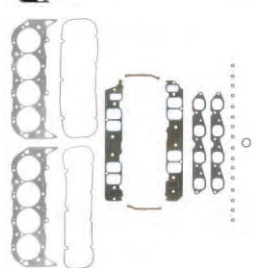
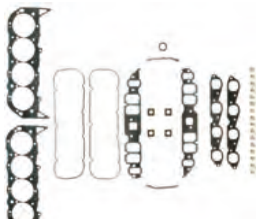
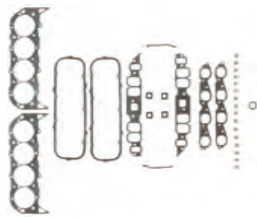
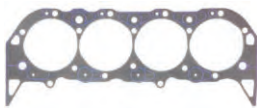

Ref	R.O. OEM	Descripción	Description	Descrizione
FEL17048		JUNTA CULATA Gene IV, V & VI Se necesitan 2.	CYLINDER HEAD Gene IV, V & VI. 2 required.	GUARNIZIONE TESTATA Gene IV, V & VI. Ne servono 2.
		<b>SUPERIOR</b>	<b>HEAD SET</b>	<b>PARTE ALTA</b>
FEL17248		KIT JUNTAS SUPERIOR Gene IV, V & VI Se necesitan 2.	ASKET HEAD SET Gene IV, V & VI. 2 required.	KIT PARTE ALTA Gene IV, V & VI. Ne servono 2.
FEL17249		KIT JUNTAS SUPERIOR Gene V exc. EFI Se incluye retenes de válvula. Juntas tapa valvula de goma.	GASKET HEAD SET Gene V exc. EFI. Molded rubber valve cover & premium valve stem seals incl.	KIT PARTE ALTA Gene V Ecc. EFI. Paraoli valvole inclusi.
FEL17281		KIT JUNTAS SUPERIOR Gene V sólo EFI Se incluye retenes de válvula. Juntas tapa valvula de goma.	GASKET HEAD SET Gene V only EFI Molded rubber valve cover & premium valve stem seals incl.	KIT PARTE ALTA Gene V solo EFI. Si include paraoli valvole.
FEL17207		KIT JUNTAS SUPERIOR Gene VI sólo EFI. Se incluye retenes de válvula. Juntas tapa valvula de goma.	GASKET HEAD SET Gene VI only EFI. Molded rubber valve cover & premium valve stem seals incl.	KIT PARTE ALTA Gene VI solo EFI Si include paraoli valvole.
		<b>INFERIOR</b>	<b>CONVERSION</b>	<b>PARTE BASSA</b>
FEL17140		KIT JUNTAS INFERIOR Gene IV Con retén trasero de 2 piezas y junta cárter de 4 piezas.	CONVERSION GASKET SET Gene IV With 2 pieces rear main bearing seal & 4 pieces oil pan gasket.	KIT PARTE BASSA Gene IV Con paraolio posteriore in 2 pz e guarnizione coppa in 4 pz.
FEL17145		KIT JUNTAS INFERIOR Gene V Con retén trasero de 1 pieza y junta cárter de 1 pieza. Junta cárter de goma y incluida.	CONVERSION GASKET SET Gene V With 1 piece rear main bearing seal & 1 piece oil pan gasket. Molded rubber oil pan gasket. incl.	KIT PARTE BASSA Gene V Con paraolio posteriore di 1 pz e guarnizione coppa in 1 pz.
FEL17146		KIT JUNTAS INFERIOR Gene VI Con retén trasero de 1 pieza y junta cárter de 1 pieza. Junta cárter de goma incluida.	CONVERSION GASKET SET Gene VI With 1 piece rear main bearing seal & 1 piece oil pan gasket. Molded rubber oil pan gasket. incl.	KIT PARTE BASSA Gene VI Con paraolio posteriore in 1 pz, guarnizione coppa in 1 pz.
		<b>COLECTOR ADMISIÓN- ESCAPE</b>	<b>MANIFOLD INTAKE &amp; EXHAUST</b>	<b>ASPIRAZIONE - SCARICO</b>
FEL17342		JUNTA ADMISIÓN Gene V & VI solo EFI	INTAKE GASKET Gene V & VI only EFI	GUARNIZIONE ASPIRAZI- ONE Gene V & VI solo EFI

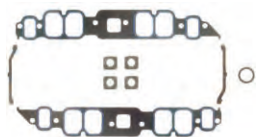

Ref	R.O. OEM	Descripción	Description	Descrizione
FEL17341		JUNTA ADMISIÓN Gene IV, V y VI sólo H.O.	INTAKE GASKET Gene IV, V & VI, H.O. only	GUARNIZIONE ASPIRAZIONE Gene IV, V e VI, solo H.O.
FEL17440		JUNTA ESCAPE Gene V & VI	EXHAUST GASKET Gene V & VI	GUARNIZIONE SCARICO Gene V & VI
		<b>CARTER</b>	<b>OIL PAN</b>	<b>COPPA DELL'OLIO</b>
FEL17985		JUNTA CARTER Gene IV Junta de 4 piezas.	GASKET OIL PAN Gene IV with 4 piece oil pan gasket.	GUARNIZIONE Gene IV, 4 pz,
FEL17986		JUNTA CARTER 1 pieza, incluye junta de goma	GASKET OIL PAN 1 piece oil pan gasket. rubber gasket included.	GUARNIZIONE 1 pz, guarnizione in gomma inclusa
		<b>RETÉN TRASERO CIGÜEÑAL</b>	<b>CRANKSHAFT REAR SEAL</b>	<b>PARAOLIO POSTERIORE ALBERO MOTORE</b>
FEL17740		KIT JUNTAS Gene IV Contrarrotación, goma; 2 piezas	GASKET KIT Rev. rotation, rubber; 2 piece	KIT GUARNIZIONE. Gene IV controrotante, gomma. 2 pz
		<b>TAPA VÁLVULAS</b>	<b>VALVE COVER</b>	<b>COPERCHIO VALVOLE</b>
FEL17935		KIT JUNTAS Gene IV	GASKET KIT Gene IV	KIT GUARNIZIONE. Gene IV
FEL17937		KIT JUNTAS Gene V sólo EFI & VI juntas de goma incluidas.	GASKET KIT Gene V (EFI oly) & VI rubber gasket included.	KIT GUARNIZIONE. Gene V. solo EFI & VI guarnizione in gomma incluso

**4 CIL  
2.3L FORD**







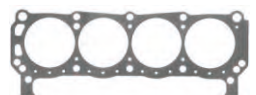

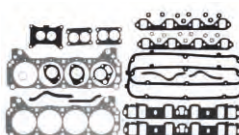

Ref	R.O. OEM	Descripción	Description	Descrizione
		<b>COLECTOR ADMISIÓN- ESCAPE</b>	<b>MANIFOLD INTAKE &amp; EXHAUST</b>	<b>ASPIRAZIONE - SCARICO</b>
REC912471	912471	JUNTA ADMISIÓN	INTAKE GASKET	GUARNIZIONE ASPIRAZIONE
REC913393	913393	JUNTA ESCAPE	EXHAUST GASKET	GUARNIZIONE SCARICO

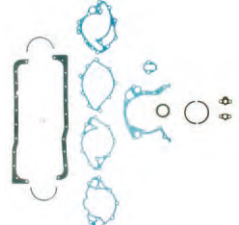
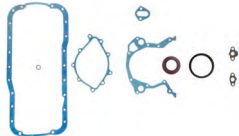
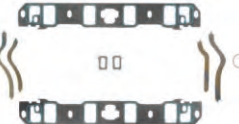
**8 CIL  
5.0 L (160, 170, 185 HP), 5.0L HIGH OUTPUT (175, 190, 200 HP),  
175 HP, 190 HP - FORD 302 (5.0)**



Ref	R.O. OEM	Descripción	Description	Descrizione
		<b>CULATA</b>	<b>CYLINDER HEAD</b>	<b>TESTATA</b>
FEL17060		JUNTAS	GASKET	GUARNIZIONE

Ref	R.O. OEM	Descripción	Description	Descrizione
 FEL17260		KIT JUNTAS Con tapa válvula sellada	GASKET SET Sealed valve cover	KIT GUARNIZIONE Coperchio valvole in acciaio
 FEL17261		KIT JUNTAS Con tapa válvula de aluminio	GASKET SET Aluminium valve cover	KIT GUARNIZIONE Coperchio valvole in alluminio
		<b>INFERIOR</b>	<b>CONVERSION</b>	<b>PARTE BASSA</b>
 FEL17160		KIT JUNTAS INFERIOR 4 piezas.	CONVERSION GASKET SET 4 piece oil pan gasket.	KIT PARTE BASSA 4 pz
 FEL17161		KIT JUNTAS INFERIOR 1 pieza	CONVERSION GASKET SET 1 piece	KIT PARTE BASSA 1 pz
		<b>COLECTOR ADMISIÓN- ESCAPE</b>	<b>MANIFOLD INTAKE &amp; EXHAUST</b>	<b>ASPIRAZIONE - SCARICO</b>
 FEL17360		KIT JUNTAS ADMISIÓN	INTAKE GASKET KIT	KIT GUARNIZIONE ASPIRAZIONE
 FEL17460		KIT JUNTAS ESCAPE	EXHAUST GASKET KIT	KIT GUARNIZIONE SCARICO
		<b>CARTER</b>	<b>OIL PAN</b>	<b>COPPA DELL'OLIO</b>
 FEL17995		JUNTA CARTER 4 piezas.	GASKET OIL PAN 4 piece	GUARNIZIONE 4 pz,
 FEL17997		JUNTA CARTER 1 pieza	GASKET OIL PAN 1 piece	GUARNIZIONE 1 pz,
		<b>RETÉN TRASERO CIGÜEÑAL</b>	<b>CRANKSHAFT REAR SEAL</b>	<b>PARAOLIO POSTERIORE ALBERO MOTORE</b>
 FEL17746		KIT JUNTAS Contrarrotación	GASKET KIT Rev. rotation	KIT GUARNIZIONE. controrotante
		<b>TAPA VÁLVULAS</b>	<b>VALVE COVER</b>	<b>COPERCHIO VALVOLE</b>
 FEL17945		KIT JUNTAS con tapa válvula sellada	GASKET KIT Sealed valve cover	KIT GUARNIZIONE. con coperchio valvole



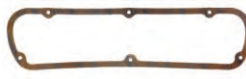
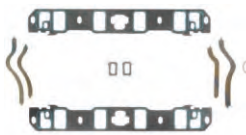
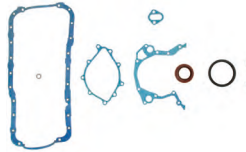
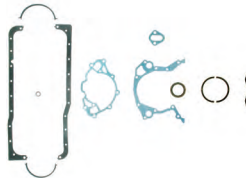
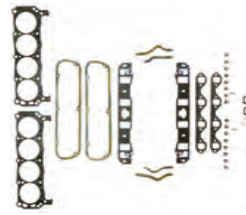
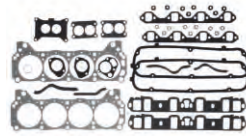
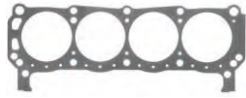

**8 CIL**  
**5.8L (210, 215, 235 HP), 5.8L COBRA (240 HP),**  
**250 HP, 351 KING COBRA (260 HP), FORD 351W**

Ref	R.O. OEM	Descripción	Description	Descrizione
		<b>CULATA</b>	<b>CYLINDER HEAD</b>	<b>TESTATA</b>
FEL17060		JUNTAS	GASKET	GUARNIZIONE
FEL17260		KIT JUNTAS SUPERIOR Con tapa válvula sellada	GASKET SET Sealed valve cover	KIT GUARNIZIONE Coperchio valvole in acciaio
FEL17261		KIT JUNTAS SUPERIOR Con tapa válvula de aluminio	GASKET SET Aluminium valve cover	KIT GUARNIZIONE Coperchio valvole in alluminio
		<b>INFERIOR</b>	<b>CONVERSION</b>	<b>PARTE BASSA</b>
FEL17165		KIT JUNTAS INFERIOR 4 piezas.	CONVERSION GASKET SET 4 piece oil pan gasket.	KIT PARTE BASSA 4 pz
FEL17166		KIT JUNTAS INFERIOR 1 pieza	CONVERSION GASKET SET 1 piece	KIT PARTE BASSA 1 pz
		<b>COLECTOR ADMISIÓN- ESCAPE</b>	<b>MANIFOLD INTAKE &amp; EXHAUST</b>	<b>ASPIRAZIONE - SCARICO</b>
FEL17360		KIT JUNTA ADMISIÓN	INTAKE GASKET KIT	KIT GUARNIZIONE ASPIRAZIONE
FEL17460		KIT JUNTA ESCAPE	EXHAUST GASKET KIT	KIT GUARNIZIONE SCARICO
		<b>CARTER</b>	<b>OIL PAN</b>	<b>COPPA DELL'OLIO</b>
FEL17996		JUNTA CARTER 4 piezas.	GASKET OIL PAN 4 piece	GUARNIZIONE 4 pz,
FEL17998		JUNTA CARTER 1 pieza	GASKET OIL PAN 1 piece	GUARNIZIONE 1 pz,
		<b>TAPA VÁLVULAS</b>	<b>VALVE COVER</b>	<b>COPERCHIO VALVOLE</b>
FEL17945		KIT JUNTAS con tapa válvula sellada	GASKET KIT Sealed valve cover	KIT GUARNIZIONE. con coperchio valvole
FEL17946		KIT JUNTAS con tapa válvula en aluminio	GASKET KIT Aluminium sealed valve cover	KIT GUARNIZIONE. coperchio valvole in alluminio

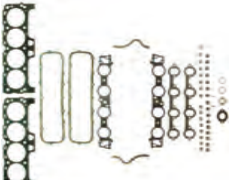
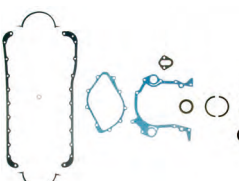
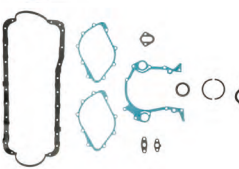
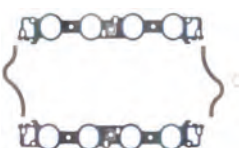
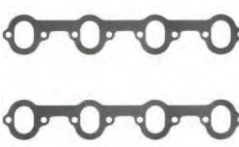

**8 CIL**  
**460 KING COBRA (295, 340 HP), FORD 460 (7.5L)**

Ref	R.O. OEM	Descripción	Description	Descrizione
		<b>CULATA</b>	<b>CYLINDER HEAD</b>	<b>TESTATA</b>
 FEL17068		JUNTAS	GASKET	GUARNIZIONE
 FEL17268		KIT JUNTAS Con tapa válvula sellada	GASKET SET Sealed valve cover	KIT GUARNIZIONE Coperchio valvole in acciaio
		<b>INFERIOR</b>	<b>CONVERSION</b>	<b>PARTE BASSA</b>
 FEL17168		KIT JUNTAS INFERIOR 4 piezas.	CONVERSION GASKET SET 4 piece oil pan gasket.	KIT PARTE BASSA 4 pz
 FEL17169		KIT JUNTAS INFERIOR 1 pieza	CONVERSION GASKET SET 1 piece	KIT PARTE BASSA 1 pz
		<b>COLECTOR ADMISIÓN- ESCAPE</b>	<b>MANIFOLD INTAKE &amp; EXHAUST</b>	<b>ASPIRAZIONE - SCARICO</b>
 FEL17368		KIT JUNTA ADMISIÓN	INTAKE GASKET KIT	KIT GUARNIZIONE ASPIRAZIONE
 FEL17468		KIT JUNTA ESCAPE	EXHAUST GASKET KIT	KIT GUARNIZIONE SCARICO
		<b>CARTER</b>	<b>OIL PAN</b>	<b>COPPA DELL'OLIO</b>
 FEL17994		JUNTA CARTER 1 pieza	GASKET OIL PAN 1 piece	GUARNIZIONE 1 pz,
		<b>TAPA VÁLVULAS</b>	<b>VALVE COVER</b>	<b>COPERCHIO VALVOLE</b>
 FEL17947		KIT JUNTAS	GASKET KIT	KIT GUARNIZIONE.

# COLECTORES Y CODOS MANIFOLDS & ELBOWS COLLETTORI E GOMITI

120HP, 4 CYL. 153CID / 2.5L GM SERIES 400

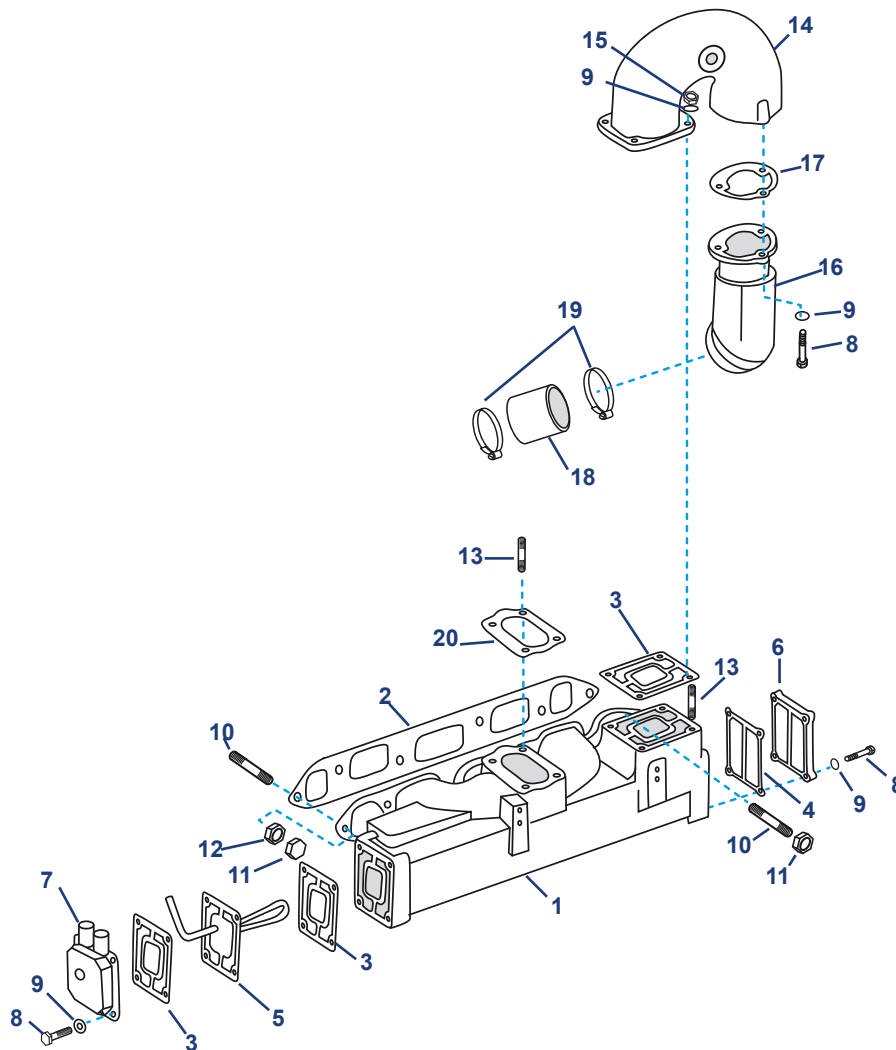

Nº	Ref.	R.O. OEM	Descripción	Description	Descrizione
1	BAOMC1-981462	981462	COLECTOR ESCAPE	EXHAUST MANIFOLD ASSEMBLY	COLLETTORE SCARICO
2	REC27-52546	311068	JUNTA COLECTOR	GASKET - EXHAUST MANIFOLD	GUARNIZIONE
2	FEL17300	311068	KIT JUNTAS COLECTOR	GASKET KIT - EXHAUST MANIFOLD	KIT GUARNIZIONI
3	REC311121	311121	JUNTA CODO A TAPA	GASKET - EXHAUST ELBOW AND END CAP	GUARNIZIONE
4	REC907761	907761	JUNTA TAPA	GASKET - END CAP	GUARNIZIONE
5	BA1-380446	380446	INTERCAMBIADOR DE CALOR	HEAT EXCHANGE ASSEMBLY	SCAMBIATORE DI CALORE
6	BAOMC1-907885	907885	TAPA TRASERA	END CAP - REAR	COPERCHIO POSTERIORE
7	BA1-910280	910280	TAPA DELANTERA	END CAP - FRONT	COPERCHIO ANTERIORE
8	REC317624	552940	TORNILLO	SCREW	VITE
9	REC13-39107	306470	CIERRE	LOCKWASHER	CHIUSURA
10	REC16-56826	3852093	PERNO	STUD	PERNO
11	REC11-862903	552938	TUERCA	NUT	DADO
12	REC13-35048	120177	CIERRE	LOCKWASHER	CHIUSURA
13	REC310870	310870	PERNO	STUD	PERNO
14	BAOMC20-980536	980536	CODO ESCAPE	EXHAUST ELBOW ASSEMBLY	GOMITO SCARICO
15	REC3852142	306422	TUERCA	NUT	DADO
16	REC909368	909368	CODO	ELBOW	GOMITO
17	REC907764	907764	JUNTA CODO A TAPA	GASKET - ELBOW	GUARNIZIONE
18	REC909371	909371	MANGUITO ESCAPE CODO	EXHAUST HOSE - ELBOW	MANICOTO SCARICO
19	GS38320	3852604	ABRAZADERA MANGUITO	CLAMP - EXHAUST HOSE	FASCETTA MANICOTTO
20	REC315055	315055	JUNTA CARBURADOR	GASKET - CARBURETOR	GUARNIZIONE CARBURATORE

120HP, 4 CIL. 153CID / 2.5L GM (1981-86)

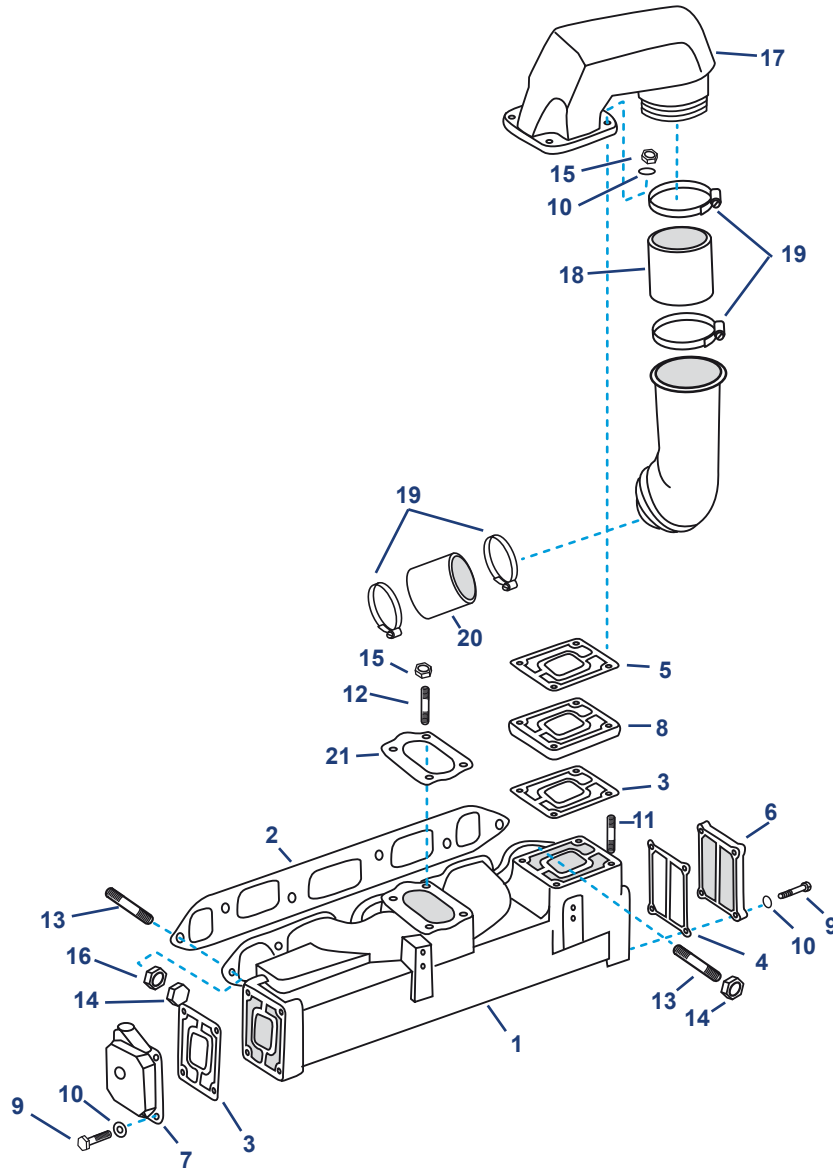

Nº	Ref.	R.O. OEM	Descripción	Description	Descrizione
1	BAOMC1-982657	982657	COLECTOR ESCAPE	EXHAUST MANIFOLD ASSEMBLY	COLLETTORE SCARICO
2	REC27-52546	311068	JUNTA COLECTOR ESCAPE	GASKET - EXHAUST MANIFOLD	GUARNIZIONE COLLETTORE
2	FEL17300	311068	KIT JUNTAS COLECTOR	GASKET KIT - EXHAUST MANIFOLD	KIT GUARNIZIONE
3	REC311121	311121	JUNTA TAPA Y ESPACIADOR	GASKET - END CAP AND SPACER	GUARNIZIONE
4	REC907761	907761	JUNTA TAPA	GASKET - END CAP	GUARNIZIONE
5	REC3850495	3850495	JUNTA CODO ESCAPE	GASKET - EXHAUST ELBOW	GUARNIZIONE SCARICO
6	BAOMC1-907885	907885	TAPA TRASERA	END CAP - REAR	COPERCHIO POSTERIORE
7	BA1-910384	910384	TAPA DELANTERA	END CAP - FRONT	COPERCHIO ANTERIORE
8	BAOMC20-908014	908014	ESPACIADOR	SPACER	DISTANZIALI
9	REC317624	552940	TORNILLO	SCREW	VITE
10	REC13-39107	306470	CIERRE	LOCKWASHER	CHIUSURA
11	REC910389	910389	PERNO	STUD	PERNO
12	REC310870	310870	PERNO	STUD	PERNO
13	REC16-56826	120177	PERNO	STUD	PERNO
14	REC11-862903	552938	TUERCA	NUT	DADO
15	REC3852142	306422	TUERCA	NUT	DADO
16	REC13-35048	120177	CIERRE	LOCKWASHER	CHIUSURA
17	BAOMC20-910380	3850799	CODO ESCAPE	EXHAUST ELBOW ASSEMBLY	GOMITO SCARICO
18	REC909232	909232	MANGUITO ESCAPE	EXHAUST HOSE	MANICOTO SCARICO
19	GS38320	3852604	ABRAZADERA	CLAMP	FASCETTA
20	REC909371	909371	MANGUITO ESCAPE	EXHAUST HOSE	MANICOTO SCARICO
21	REC315055	315055	JUNTA CARBURADOR	GASKET - CARBURETOR	GUARNIZIONE CARBURATORE

140HP, 4 CIL. 181CID / 3.0L GM (1973-90)

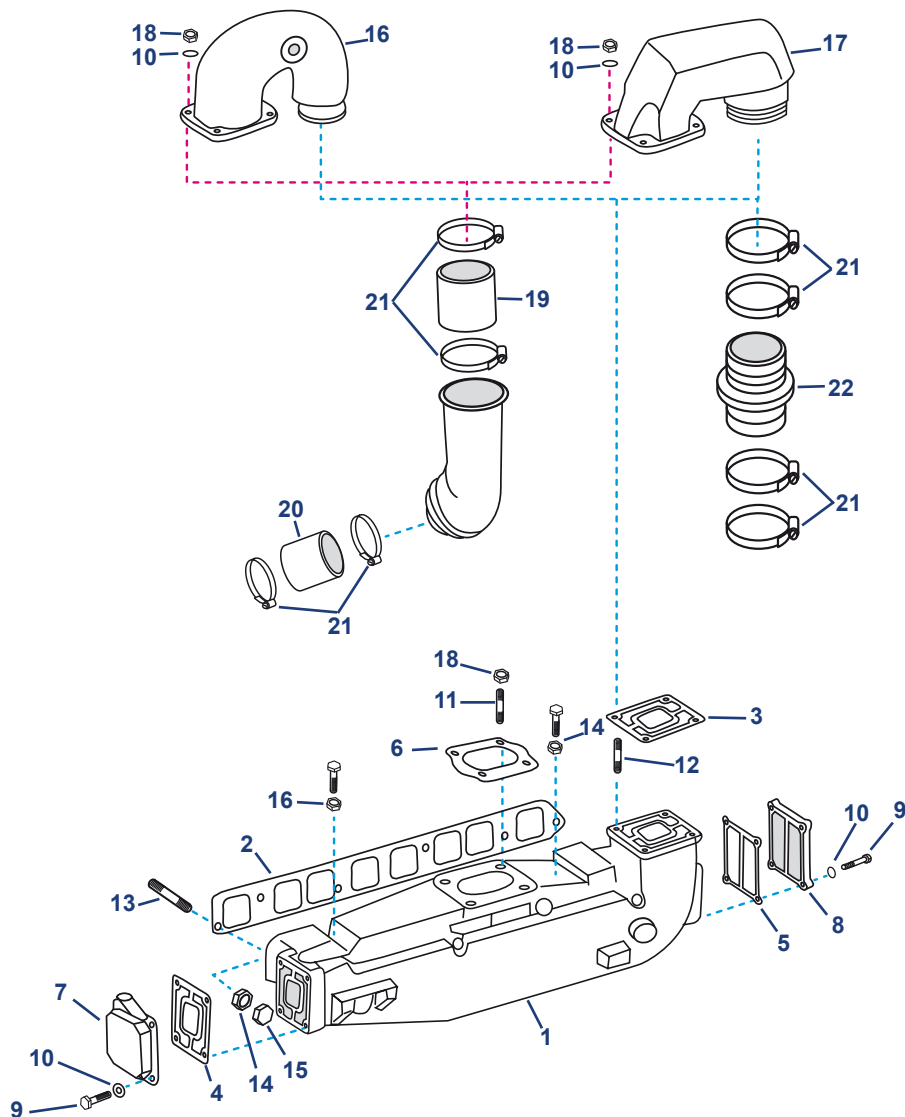

Nº	Ref.	R.O. OEM	Descripción	Description	Descrizione
1	BAOMC1-984054	984054	COLECTOR ESCAPE	EXHAUST MANIFOLD ASSEMBLY	COLLETTORE SCARICO
2	REC27-53354	908079	JUNTA COLECTOR ESCAPE	GASKET - EXHAUST MANIFOLD	GUARNIZIONE COLLETTORE
2	FEL17301	908079	KIT JUNTAS COLECTOR	GASKET KIT - EXHAUST MANIFOLD	KIT GUARNIZIONE
3	REC3850495	3850495	JUNTA CODO	GASKET - EXHAUST ELBOW	GUARNIZIONE GOMITO
4	REC311121	311121	JUNTA TAPA	GASKET - END CAP	GUARNIZIONE COPERCHIO
5	REC907761	907761	JUNTA TAPA	GASKET - END CAP	GUARNIZIONE COPERCHIO
6	REC315055	315055	JUNTA CARBURADOR	GASKET - CARBURETOR	GUARNIZIONE CARBURATORE
7	BA1-910384	910384	TAPA TRASERA	END CAP - FRONT	GUARNIZIONE POSTERIORE
8	BAOMC1-907885	907885	TAPA DELANTERA	END CAP - REAR	GUARNIZIONE ANTERIORE
9	REC317624	552940	TORNILLO TAPA	SCREW - END CAP	COPERCHIO
10	REC13-39107	306470	CIERRE	LOCKWASHER	CHIUSURA
11	REC16-70236	314616	PERNO CARBURADOR	STUD - CARBURETOR	PERNO CARBURATORE
12	REC310870	310870	PERNO CODO ESCAPE	STUD - EXHAUST ELBOW	PERNO GOMITO
13	REC16-56826	3852093	PERNO COLECTOR ESCAPE	STUD - EXHAUST MANIFOLD	PERNO COLLETTORE
14	REC13-35048	120177	CIERRE	LOCKWASHER	CHIUSURA
15	REC11-862903	552938	TUERCA	NUT	DADO
16	OSC0188	980020	CODO ESCAPE 1972-73 100/120/140/165 HP	EXHAUST ELBOW ASSEMBLY 1972-73 100/120/140/165 HP	GOMITO SCARICO 1972-73 100/120/140/165 HP
17	BAOMC20-910380	3850799	CODO ESCAPE OTROS MODELOS	EXHAUST ELBOW ASSEMBLY (ALL OTHER)	GOMITO SCARICO ALTRI MODELLI
18	REC3852142	306422	TUERCA	NUT	DADO
19	REC909232	909232	MANGUITO ESCAPE	EXHAUST HOSE	MANICOTTO SCARICO
20	REC909371	909371	MANGUITO ESCAPE	EXHAUST HOSE	MANICOTO SCARICO
21	GS38320	3852604	ABRAZADERA	CLAMP	FASCETA
22	REC3863450	3852741	MANGUITO ESCAPE	EXHAUST HOSE	MANICOTTO SCARICO

### 4.3 / 4.3 H.O. GM 262 CID V6 (1986-90)

Este colector ya no se fabrica. Para sustituirlo utilizar todas las piezas del motor modelo: 4.3GM (1991+)  
This manifold is obsolete. Parts of the 4.3GM (1991+) must be used to replace it.  
Kit di trasformazione: qui sotto troverete i pezzi necessari per sostituire il collettore: 4.3 GM (1991+)



### 4.3 GM 262 CID V6 (1991+)

Ref.	R.O. / OEM
REC53773	
<p>Kit juntas y tornillería Exhaust gasket hardware set Kit guarnizione e bulloneria</p>	
Ref.	R.O. / OEM
REC3862500	3862500
<p>Sensor temperatura Temperature sensor Sensore Temperatura</p>	

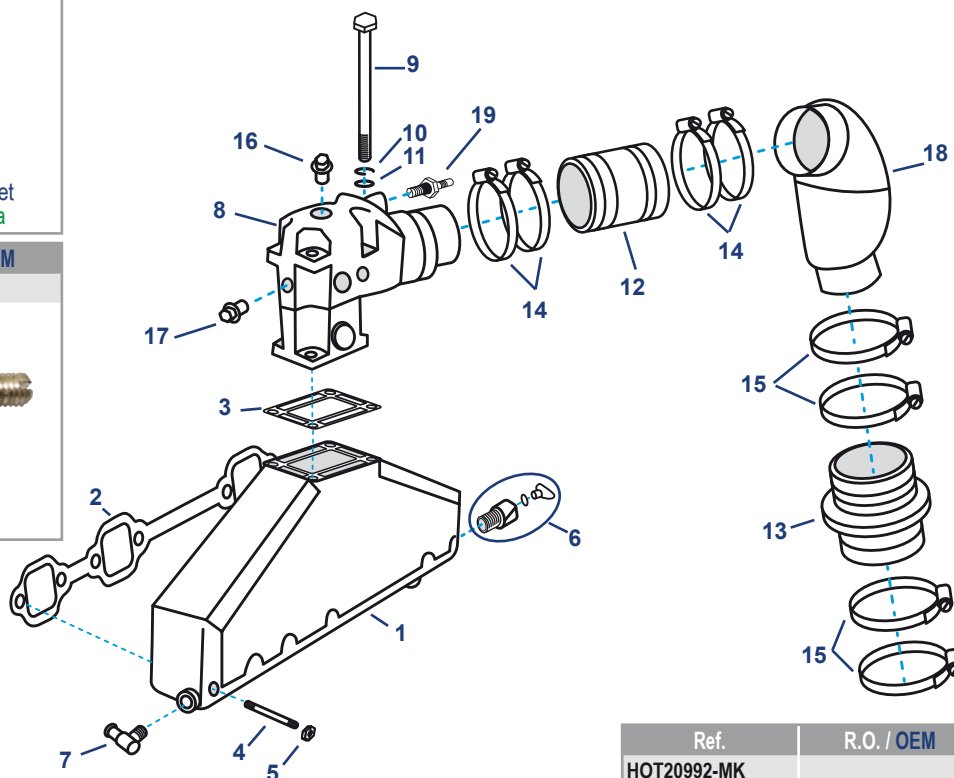

Ref.	R.O. / OEM
HOT20992-MK	
<p>Kit juntas y tornillería Exhaust gasket hardware set Kit guarnizione e bulloneria</p>	

Nº	Ref.	R.O. OEM	Descripción	Description	Descrizione
1	MAR499	3847499	COLECTOR ESCAPE	EXHAUST MANIFOLD ASSEMBLY	COLLETTORE SCARICO
2	REC27-99757	3853412	JUNTA COLECTOR ESCAPE	GASKET - EXHAUST MANIFOLD	COLLETTORE SCARICO
2	FEL17410	3853412	KIT JUNTAS COLECTOR ESCAPE	GASKET KIT- EXHAUST MANIFOLD	GUARNIZIONE SCARICO
3	REC3863191	351325	JUNTA CODO ESCAPE	GASKET - EXHAUST ELBOW	KIT GUARNIZIONE COLLETTORE SCARICO
4	REC3852467	3852467	PERNO	STUD	PERNO
5	REC46335	3853404	TUERCA	NUT	DADO
6	REC479956		RACOR COLECTOR	STRAIGHT FITTING	RACCORDO
7	REC3852538	3852538	TORNILLO CODO	ELBOW FITTING	VITE GOMITO
8	MAR061	3857944	CODO ESCAPE	EXHAUST ELBOW ASSEMBLY	GOMITO SCARICO
9	REC3852830	3852830	TORNILLO	SCREW	VITE
10	REC13-35048	120177	CIERRE	LOCKWASHER	CHIUSURA
11	REC21-20553	306405	ARANDELA	WASHER	RONDELLA
12	REC3852696	3852696	MANGUITO ESCAPE	EXHAUST HOSE	MANICOTTO SCARICO
13	REC3863450	3852741	MANGUITO ESCAPE	EXHAUST HOSE	MANICOTTO SCARICO
14	GS38322	3853860	ABRAZADERA	CLAMP	FASCETTA
15	GS38320	3852604	ABRAZADERA	CLAMP	FASCETTA
16	REC22-73379		TAPÓN	PLUG	TAPPO
17	REC22-428611	315713	TAPÓN	PLUG	TAPPO
18	RM3854874	3854874	CURVA (1991-98) COLA SX	ELBOW SYSTEM DRIVE SX (1991-98)	CURVA (1991-98) PIEDE SX
19	REC3862500	3862500	SENSOR TEMPERATURA	TEMPERATURE SENSOR	SENSORE TEMPERATURA

**800 GM 305/350 CID V8  
BLOQUE PEQUEÑO / SMALL BLOCK / BLOCCO PICCOLO (1979-89)**

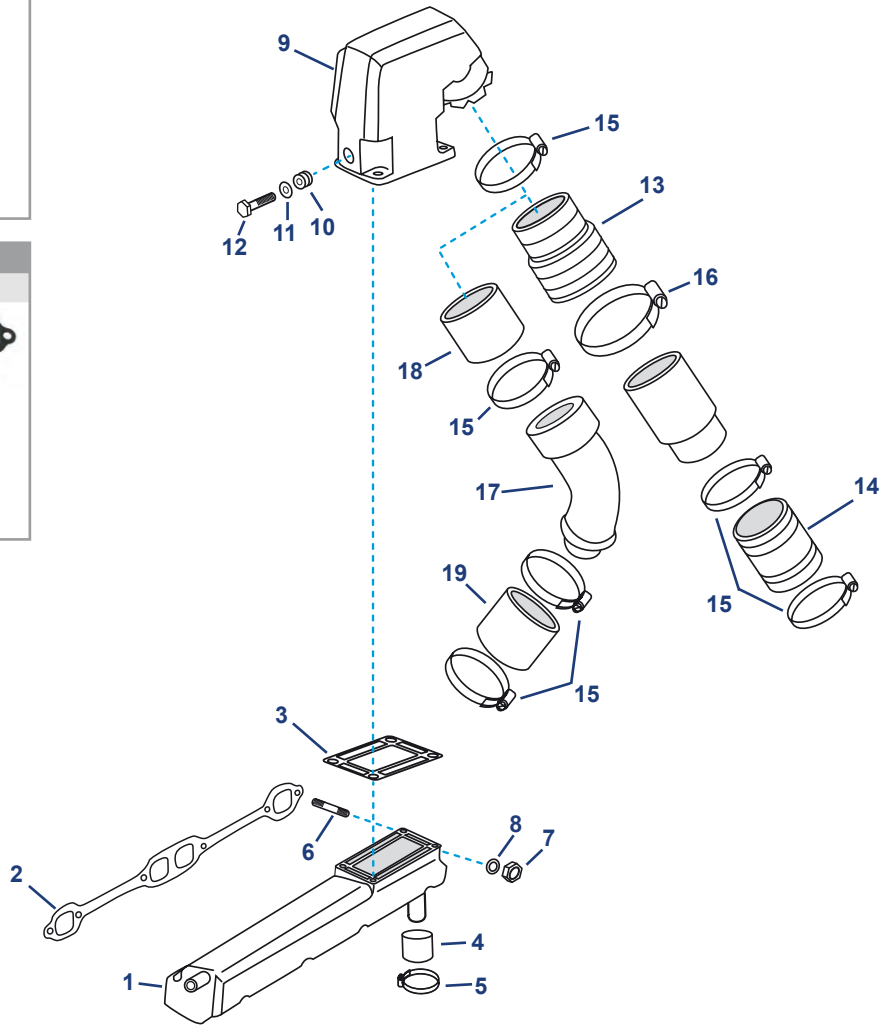

Nº	Ref.	R.O. OEM	Descripción	Description	Descrizione
1	HOT20902	912441	COLECTOR ESCAPE ESTRIBOR	EXHAUST MANIFOLD ASSEMBLY - STBD	COLLETTORE SCARICO TRIBORDO
1	HOT20903	912442	COLECTOR ESCAPE BABOR	EXHAUST MANIFOLD ASSEMBLY - PORT	COLLETTORE SCARICO BABORDO
2	REC27-33395	3852468	JUNTA COLECTOR ESCAPE	GASKET - EXHAUST MANIFOLD	GUARNIZIONE COLLETTORE SCARICO
2	FEL17420	3852468	KIT JUNTA COLECTOR ESCAPE	GASKET KIT - EXHAUST MANIFOLD	KIT GUARNIZIONE COLLETTORE SCARICO
3	REC3863191	3863191	JUNTA CODO ESCAPE	GASKET - EXHAUST ELBOW	GUARNIZIONE GOMITO SCARICO
4	REC764799	764799	TAPA	CAP	COPERCHIO
5	REC54-815504320	3853786	ABRAZADERA	CLAMP	FASCETTA
6	REC3852467	3852467	PERNO	STUD	PERNO
7	REC46335	908700	TUERCA	NUT	DADO
8	REC13-35048	309336	CIERRE	LOCKWASHER	CHIUSURA
9	HOT20921	909863	CODO ESCAPE	EXHAUST ELBOW ASSEMBLY	GOMITO SCARICO
10	REC22-428611	315713	TAPÓN	PLUG	TAPPO
11	REC3853397	306435	TORNILLO	SCREW	VITE
12	REC13-39107	306325	CIERRE	LOCKWASHER	CHIUSURA
13	REC912374	912374	MANGUITO ESCAPE (COBRA)	EXHAUST HOSE (COBRA)	MANCIOTTO SCARICO (COBRA)
14	REC3852742	3852742	MANGUITO ESCAPE (COBRA)	EXHAUST HOSE (COBRA)	MANCIOTTO SCARICO (COBRA)
15	GS38320	3852604	ABRAZADERA	CLAMP	FASCETTA
16	GS38322	984387	ABRAZADERA	CLAMP	FASCETTA
17	REC909609	909609	TUBO CODO ESTRIBOR	ELBOW TUBE - STBD (STRINGER MOUNT)	TUBO GOMITO TRIBORDO
17	REC909610	909610	TUBO CODO BABOR	ELBOW TUBE - PORT (STRINGER MOUNT)	TUBO GOMITO BABORDO
18	REC909232	909232	MANGUITO ESCAPE	EXHAUST HOSE	MANICOTTO SCARICO
19	REC909371	909371	MANGUITO ESCAPE	EXHAUST HOSE	MANICOTTO SCARICO

**5.7L GM 350 CID V8  
(1990+)**

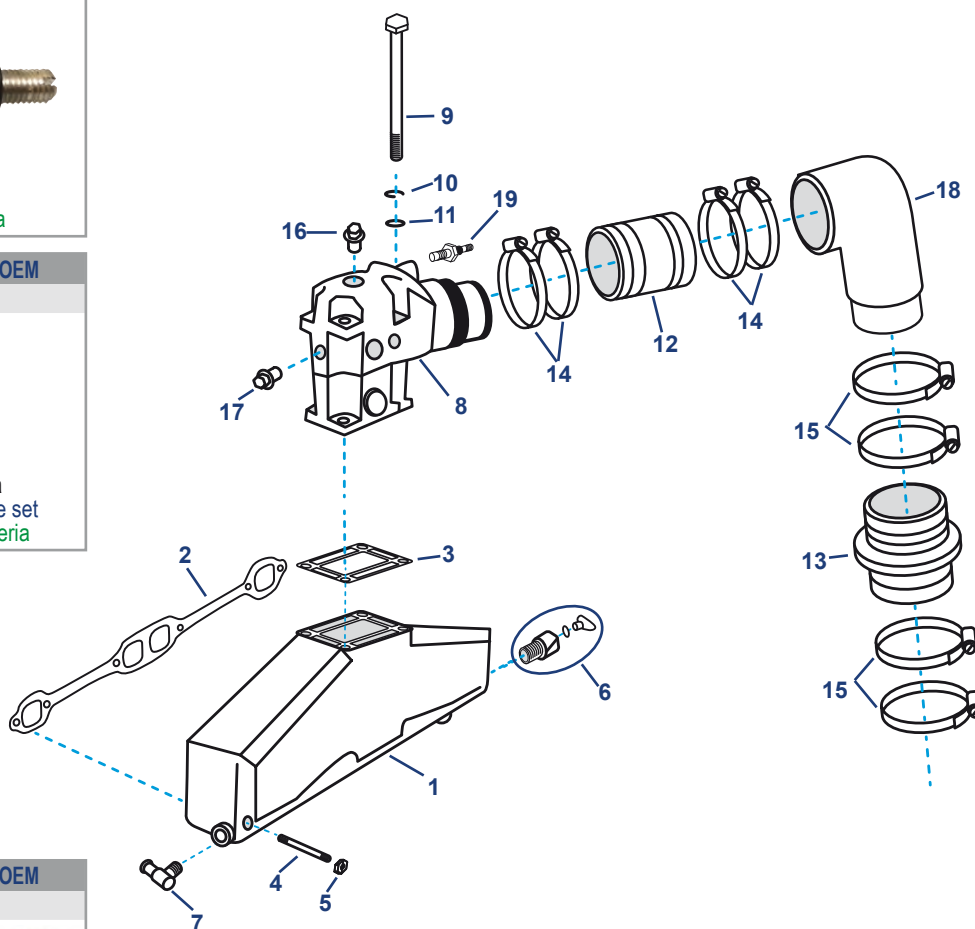
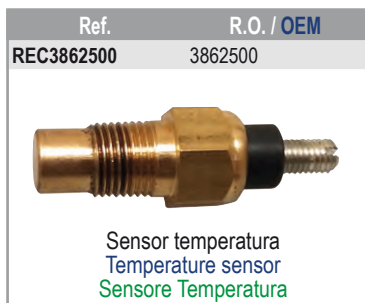

Nº	Ref.	R.O. / OEM	Descripción	Description	Descrizione
1	HOT20986	3857723	COLECTOR ESCAPE	EXHAUST MANIFOLD ASSEMBLY	COLLETTORE SCARICO
1	MAR501	3857723	COLECTOR ESCAPE	EXHAUST MANIFOLD ASSEMBLY	COLLETTORE SCARICO
2	REC27-33395	3852468	JUNTA COLECTOR ESCAPE	GASKET - EXHAUST MANIFOLD	GUARNIZIONE COLLETTORE SCARICO
2	FEL17420	3852468	KIT JUNTAS COLECTOR ESCAPE	GASKET KIT - EXHAUST MANIFOLD	KIT GUARNIZIONE COLLETTORE SCARICO
3	REC3863191	3863191	JUNTA CODO ESCAPE	GASKET - EXHAUST ELBOW	GUARNIZIONE GOMITO SCARICO
4	REC3852467	3852467	PERNO	STUD	PERNO
5	REC46335	3853404	CIERRE	LOCKNUT	CHIUSURA
6	REC479956		RACOR COLECTOR	STRAIGHT FITTING KIT	RACCORDO COLLETTORE
7	REC3852538	3852538	RACOR CODO	ELBOW FITTING	RACCORDO GOMITO
8	MAR061	3857944	CODO ESCAPE	EXHAUST ELBOW	GOMITO SCARICO
9	REC3852830	3852830	TORNILLO	SCREW	VITE
10	REC13-35048	120177	CIERRE	LOCKWASHER	CHIUSURA
11	REC21-20553	306405	ARANDELA	WASHER	RONDELLA
12	REC3852696	3852696	MANGUITO ESCAPE	EXHAUST HOSE	MANICOTTO SCARICO
13	REC3863450	3852741	MANGUITO ESCAPE	EXHAUST HOSE	MANICOTTO SCARICO
14	GS38322	3853860	ABRAZADERA	CLAMP	FASCETTA
15	GS38320	3852604	ABRAZADERA	CLAMP	FASCETTA
16	REC22-73379		TAPÓN	PLUG	TAPPO
17	REC22-428611	315713	TAPÓN	PLUG	TAPPO
18	REC763891	763891	TUBO ESCAPE	EXHAUST TUBE	TUBO SCARICO
19	REC3862500	3862500	SENSOR TEMPERATURA	TEMPERATURE SENSOR	SENSORE TEMPERTURA



**5.0/5.8L & EFI FORD 302/351 CID V8  
(1991+)**

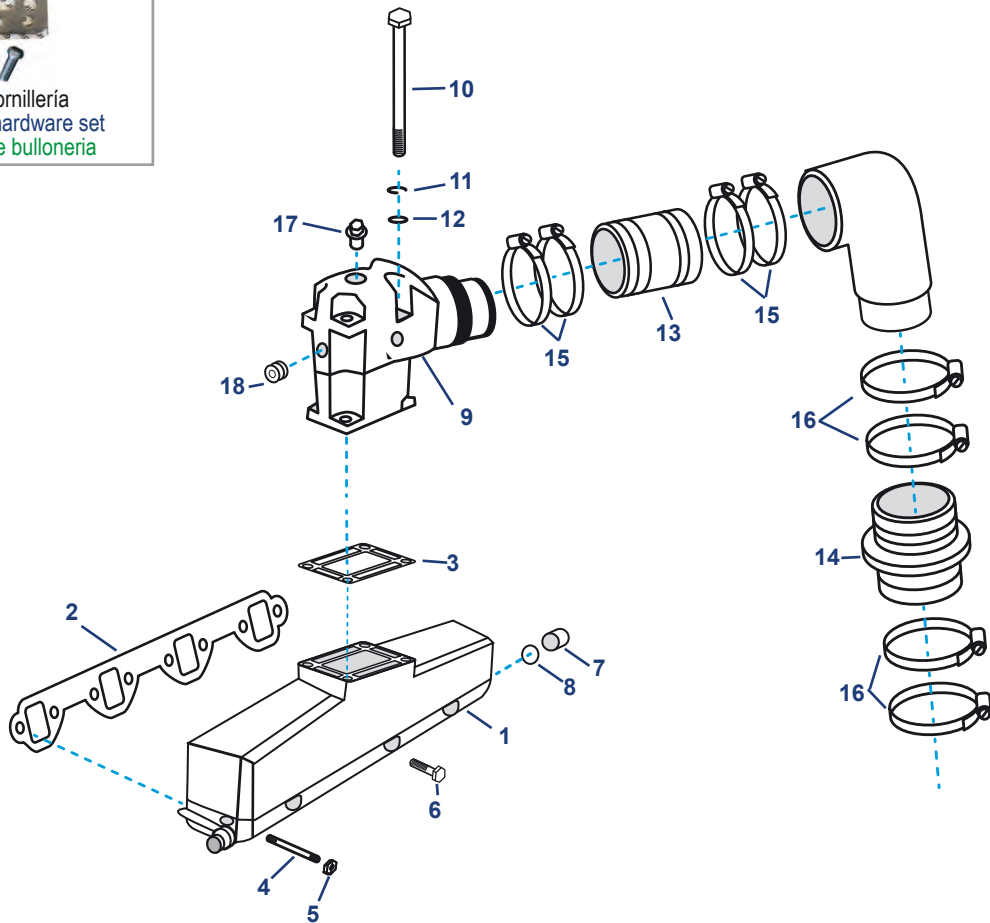

Nº	Ref.	R.O. OEM	Descripción	Description	Descrizione
1	BAOMC1-3852347	3852347	COLECTOR ESCAPE	EXHAUST MANIFOLD ASSEMBLY	COLLETTORE SCARICO
2	REC3852455	3852455	JUNTA COLECTOR ESCAPE	GASKET - EXHAUST MANIFOLD	GUARNIZIONE COLLETTORE SCARICO
2	FEL17460	3852455	KIT JUNTAS COLECTOR ESCAPE	GASKET KIT - EXHAUST MANIFOLD	KIT GUARNIZIONE COLLETTORE SCARICO
3	REC3863191	3863191	JUNTA CODO ESCAPE	GASKET - EXHAUST ELBOW	GUARNIZIONE GOMITO SCARICO
4	REC3853434	3853434	PERNO	STUD	PERNO
5	REC46335	3853404	TUERCA	NUT	DADO
6	REC10-37612	3853155	TORNILLO	SCREW	VITE
7	REC3852476	3852476	TAPA	CAP	COPERCHIO
8	REC3852602	912627	ARANDELA	CLAMP	FASCETTA
9	MAR061	3857944	CODO ESCAPE (1988-96) CARB.	EXHAUST ELBOW ASSEMBLY (1988-96 CARB.)	GOMITO SCARICO CARBURATORE (1988-96)
9	REC3855271	3855271	CODO ESCAPE BABOR (1993-96) EFI	EXHAUST ELBOW ASSLY - PORT (1993-96 EFI)	GOMITO SCARICO EFI BABORDO (1993-96)
9	REC3855269	3855269	CODO ESCAPE ESTRIBOR (1993-96) EFI	EXHAUST ELBOW ASBLY - STBD (1993-96 EFI)	GOMITO SCARICO EFI TRIBORDO (1993-96)
10	REC3852830	3852830	TORNILLO	SCREW	VITE
11	REC13-35048	120177	CIERRE	LOCKWASHER	CHIUSURA
12	REC21-20553	306405	ARANDELA	WASHER	RONDELLA
13	REC3852696	3852696	MANGUITO ESCAPE	EXHAUST HOSE	MANICOTTO SCARICO
14	REC3863450	3852741	MANGUITO ESCAPE	EXHAUST HOSE	MANICOTTO SCARICO
15	GS38322	3853860	ABRAZADERA	CLAMP	FASCETTA
16	GS38320	3852604	ABRAZADERA	CLAMP	FASCETTA
17	REC22-73379		TAPÓN	PLUG	TAPPO
18	REC22-428611	315713	TAPÓN	PLUG	TAPPO

**7.4/8.2L GM 454/502 CID V8  
(1991+)**

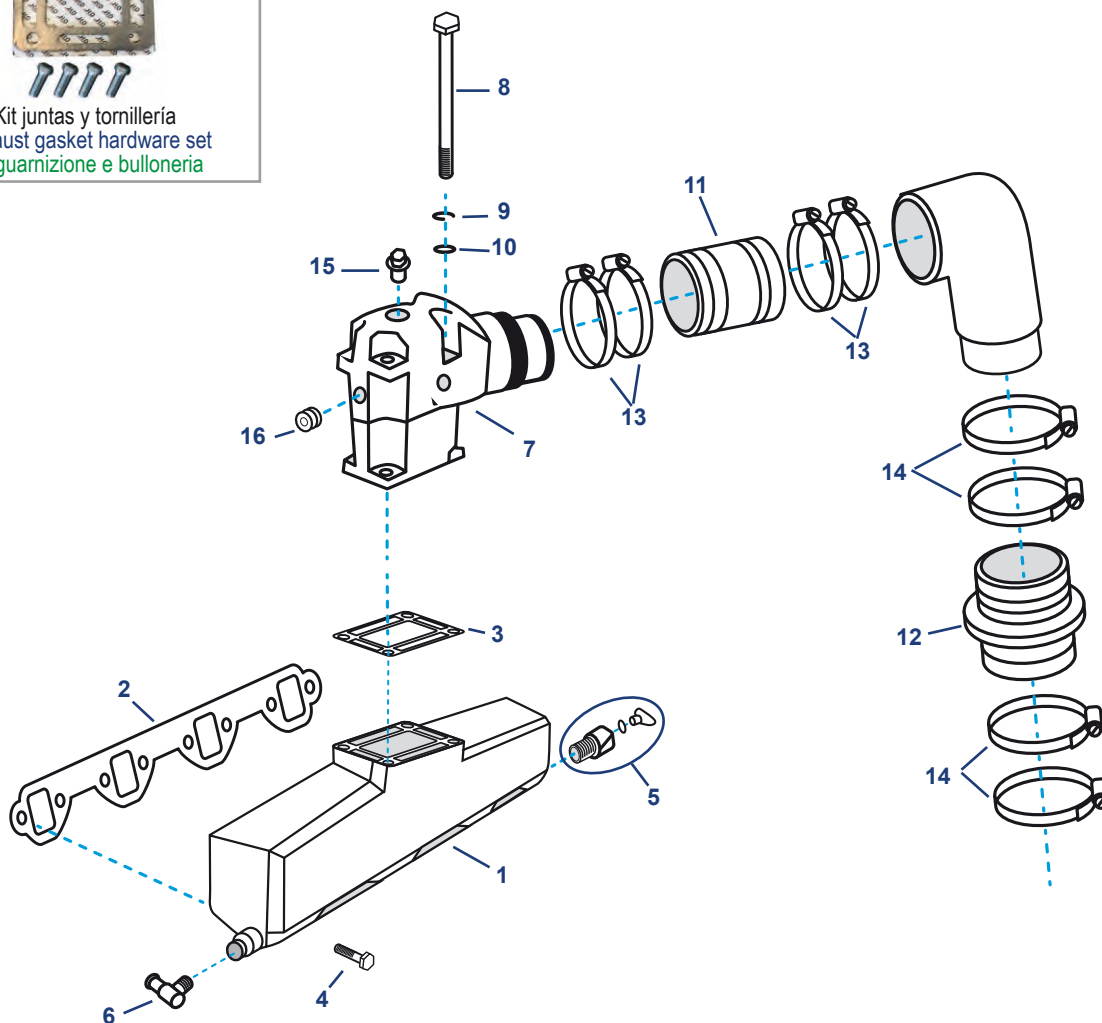

Nº	Ref.	R.O. OEM	Descripción	Description	Descrizione
1	RM3861459	3861459	COLECTOR ESCAPE	EXHAUST MANIFOLD ASSEMBLY	COLLETTORE SCARICO
2	REC27-46820	3852472	JUNTA COLECTOR ESCAPE	GASKET - EXHAUST MANIFOLD	GUARNIZIONE COLLETTORE SCARICO
2	FEL17440	3852472	KIT JUNTAS COLECTOR ESCAPE	GASKET KIT - EXHAUST MANIFOLD	KIT GUARNIZIONE COLLETTORE SCARICO
3	REC3863191	3863191	JUNTA CODO ESCAPE	GASKET - EXHAUST ELBOW	GUARNIZIONE GOMITO SCARICO
4	REC10-37612	3853326	TORNILLO	SCREW 3/8 - 16 X 1 1/4 FLANGE	PERNO
5	REC479956		RACOR COLECTOR	STRAIGHT FITTING	RACORDO COLLETTORE
6	REC3852538	3852538	RACOR CODO	ELBOW FITTING	RACORDO GOMITO
7	MAR061	3857944	CODO ESCAPE	EXHAUST ELBOW ASSEMBLY	GOMITO SCARICO
8	REC3852830	3852830	TORNILLO	SCREW	VITE
9	REC13-35048	120177	CIERRE	LOCKWASHER	CHIUSURA
10	REC21-20553	306405	ARANDELA	WASHER	RONDELLA
11	REC3852696	3852696	MANGUITO ESCAPE	EXHAUST HOSE	MANICOTTO SCARICO
12	REC3863450	3852741	MANGUITO ESCAPE	EXHAUST HOSE	MANICOTTO SCARICO
13	GS38322	3853860	ABRAZADERA	CLAMP	FASCETTA
14	GS38320	3852604	ABRAZADERA	CLAMP	FASCETTA
15	REC22-73379		TAPÓN	PLUG	TAPPO
16	REC22-428611	315713	TAPÓN	PLUG	TAPPO

**COLECTORES ESCAPE  
EXHAUST MANIFOLD  
COLLETTORE SCARICO**

Ref.	R.O. OEM
HGE6041	986041

**MOTORES / ENGINES / MOTORI**  
2.3 FORD  
4 en línea / 4 inline / 4 en rete



Ref.	R.O. OEM
BAOMC-1-980959	980959

**MOTORES / ENGINES / MOTORI**  
170, 175, 190, 235 HP  
V8  
CID302 & 351 FORD



**CODOS ESCAPE  
EXHAUST ELBOWS  
GOMITI SCARICO**

Ref.	R.O. OEM
HGE3394	914766

**MOTORES / ENGINES / MOTORI**  
2.3 FORD  
4 en línea / 4 inline / 4 en rete



Ref.	R.O. OEM
BAOMC20-981281	981281

**MOTORES / ENGINES / MOTORI**  
155HP, V6 GM



Ref.	R.O. OEM
HOT20921	909863

**MOTORES / ENGINES / MOTORI**  
240HP, 302 & 351 CID FORD



DESPIECE  
PARTS  
ESPLOSO  
P. 527

Ref.	R.O. OEM
BAOMC20-980617	980617

**MOTORES / ENGINES / MOTORI**  
170, 175, 190, 235 HP  
V8  
CID302 & 351 FORD



**JUNTAS COLECTOR  
EXHAUST MANIFOLD GASKET  
GUARNIZIONE COLLETTORE**

Ref.	R.O. OEM
REC913393	913393

**MOTORES / ENGINES / MOTORI**  
2.3 FORD  
4 en línea / 4 inline / 4 in linea



Ref.	R.O. OEM	
FEL17460	913393	KIT x 2
REC3852455	3852455	

**MOTORES / ENGINES / MOTORI**  
240HP  
302 & 351 CID FORD  
170, 175, 190, 235 HP  
V8



**JUNTAS COLECTOR ADMISIÓN  
INTAKE MANIFOLD GASKET  
GUARNIZIONE COLLETTORE  
ASPIRAZIONE**

Ref.	R.O. OEM
REC912471	912471

**MOTORES / ENGINES / MOTORI**  
FORD 140 HP 2.3L



**JUNTAS COLECTOR - CODOS  
EXHAUST MANIFOLD - ELBOW GASKET  
GUARNIZIONE  
COLLETTORE - GOMITO**

Ref.	R.O. OEM
REC878982	912477

**MOTORES / ENGINES / MOTORI**  
2.3 FORD  
4 en línea / 4 inline / 4 in linea



**JUNTAS CODOS  
ELBOW GASKET  
GUARNIZIONE GOMITO**

Ref.	R.O. OEM
REC3863191	913784

**MOTORES / ENGINES / MOTORI**  
240HP, 302 & 351 CID FORD



**TAPÓN DE GOMA  
RUBBER CAP  
TAPPO IN GOMMA**

Ref.	R.O. OEM
REC764799	764799
REC3852476	909829 3852476



**MOTORES / ENGINES / MOTORI**  
240HP, 302 & 351 CID FORD

**TAPA  
END CAP  
COPERCHIO**

Ref.	R.O. OEM
BA1-908719	908716

**MOTORES / ENGINES / MOTORI**  
170, 175, 190, 235 HP  
V8  
CID302 & 351 FORD



Ref.	R.O. OEM
BA1-312148	312148

**MOTORES / ENGINES / MOTORI**  
155HP  
V6 GM



**JUNTAS TAPA  
END CAP GASKET  
GUARNIZIONE COPERCHIO**

Ref.	R.O. OEM
BAOMC47-908935	908935

**MOTORES / ENGINES / MOTORI**  
170, 175, 190, 235 HP  
V8  
CID302 & 351 FORD



Ref.	R.O. OEM
BAOMC47-311130	311130

**MOTORES / ENGINES / MOTORI**  
155HP  
V6 GM



**BOMBA DE CIRCULACIÓN BLOQUE  
BLOCK CIRCULATING PUMP  
POMPA DI RICIRCOLO DI BLOCCO**

**BOMBAS  
PUMPS  
POMPE**

Ref.	R.O. OEM
PH600-0004	3858340

**MOTORES / ENGINES / MOTORI**  
GM 4L



Ref.	R.O. OEM
PH600-0005	3853850 985429

**MOTORES / ENGINES / MOTORI**  
GM V6 & V8 (bloque pequeño / small block /  
blocco piccolo)



Ref.	R.O. OEM
PH600-0002	3855991

**MOTORES / ENGINES / MOTORI**  
GM V8 (bloque grande / big block /  
blocco grande)



Ref.	R.O. OEM
PH600-0006	982517 3471293

**MOTORES / ENGINES / MOTO**  
Ford 5.0L & 5.8L



**MANGUITO  
HOSE  
MANICOTTO**

Ref.	R.O. OEM
CEF501003	312781
REC32-33189	312781

**MOTORES / ENGINES / MOTORI**  
COBRA



Ref.	R.O. OEM
REC32-8M0071007	0509282



# BOMBA ASPIRACIÓN AGUA MARINA RAW MARINE WATER PUMPS POMPE ASPIRAZIONE ACQUA MARINA

Ref.	R.O. OEM
SHEG9901	3858847

**MOTORES / ENGINES / MOTORI**  
4.3 & 8.2 (con colas SX / SX drives / Piedi SX)

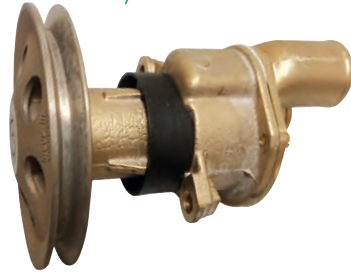

Ref.	R.O. OEM
SHEG9903	3855079
	3851982
	3857794

**MOTORES / ENGINES / MOTORI**  
3.0 L (con colas SX / SX drives / Piedi SX)

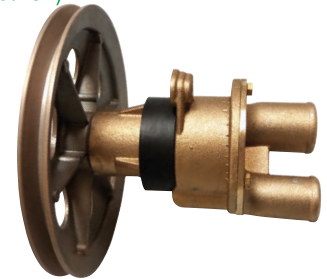

## TERMOSTATO THERMOSTAT TERMOSTATO

### KITS TERMOSTATO THERMOSTAT KITS KIT TERMOSTATI

Ref.	R.O. OEM	160 °C
REC3853799	3853799	

**MOTORES / ENGINES / MOTORI**  
Chevys 4 cil. (1980+)



Ref.	R.O. OEM
REC13430	

**MOTORES / ENGINES / MOTORI**  
Excepto / except / esclusi Chevys 4 cil. (1980+)



Ref.	R.O. OEM	140°
REC3853983		

**MOTORES / ENGINES / MOTORI**  
7.4L (1994-97)



3852111

3852071

3853983

### GUIA TERMOSTATOS Y KITS THERMOSTATS & KITS GUIDE GUIDA TERMOSTATI E KIT

MODELO MODEL MODELLO	AÑO YEAR ANNI	TERMOSTATO THERMOSTAT TERMOSTATO	KIT
90	1970		REC13430
100	1972-73		REC13430
120	1969-80		REC13430
120	1980-81	REC3853799	REC3853799
140	1973-80		REC13430
140	1980-81	REC3853799	REC3853799
155	1969-72		REC13430
165	1972-76		REC13430
170	1974		REC13430
175	1975-77		REC13430
185	1978-80		REC13430
190	1974-77		REC13430
200	1979-81		REC13430
210	1969-72		REC13430
215	1971		REC13430
225	1971		REC13430
230	1979-81		REC13430
235	1971		REC13430
235	1975-77		REC13430
240	1978		REC13430
245	1972-75		REC13430
250	1970-73		REC13430
250	1979		REC13430
260	1979-81		REC13430
305	1977-82		REC13430
350	1977-82		REC13430
454	1977-82		REC13430
2.5L	1982-88	REC3853799	REC3853799
3.0L	1982-88	REC3853799	REC3853799
3.8L	1981-85		REC13430
4.3L	1985-86		REC13430
5.0L	1982-88		REC13430
5.7L	1982-88		REC13430
7.4L	1994-97		REC3853983
7.5L	1988		REC13430

**CUERPO TERMOSTATO  
THERMOSTAT HOUSING  
CORPO TERMOSTATO**

Ref.	R.O. OEM
BAOMC29-314810	314810 982201



Ref.	R.O. OEM
BAOMC29-910303	3854254



Ref.	R.O. OEM
BAOMC29-908216	908216



Ref.	R.O. OEM
REC3850360	986292 987716 3850360

**MOTORES / ENGINES / MOTORI**  
V6 & V8



Ref.	R.O. OEM
HGE5470	985470

**MOTORES / ENGINES / MOTORI**  
Ford 2.3L



**BOMBAS COMBUSTIBLE  
FUEL PUMP  
POMPA BENZINA**

Ref.	R.O. OEM
REC3855276	981650

**MOTORES / ENGINES / MOTORI**  
GM V8, 305, 307, 350

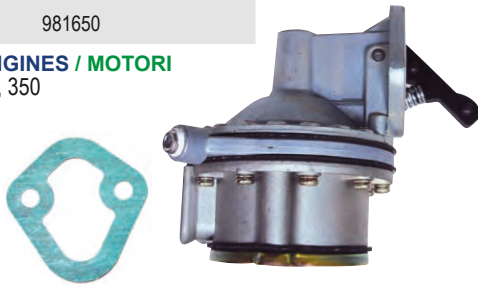

Ref.	R.O. OEM
REC62092T	982063

**MOTORES / ENGINES / MOTORI**  
FORD V8, 302



Ref.	R.O. OEM
REC86234A4	985603 982240 985602



Ref.	R.O. OEM
REC982997	982997



# FILTROS COMBUSTIBLE Y ELEMENTOS FUEL FILTERS AND ELEMENTS FILTRI COMBUSTIBILE E RACCORDI

534

## FILTRO SEPARADOR DE AGUA WATER SEPARATING FUEL FILTER FILTRO SEPARATORE ACQUA-BENZINA

Ref.	R.O. OEM
REC35-8M0061975	174144 502905



Ref.	R.O. OEM
REC3862228	987754 502906



## FILTRO ORIGINAL OEM FILTER FILTRO BENZINA ORIGINALE

Ref.	R.O. OEM
RM3862228	987754 502906



## FILTROS DECANTADORES COMPLETE FUEL FILTERS FILTRI DECANTATORE

Ref.	R.O. OEM
RAC320R-RAC-02	35-802893Q4

Con Bracket Inox y cubeta metálica.  
With Stainless Steel Bracket and metallic bowl.  
Con Bracket e vaschetta metallica.



## RECAMBIO FILTRO ELEMENT CARTUCCIA FILTRO

Ref.	R.O. OEM
RACS3220UL	35-809101



## FILTRO CON BRACKET FILTER WITH BRACKET FILTRO CON SUPPORTO

Ref.	R.O. OEM	MICRAS MICRON MICRON	TOMAS NPTF PORTS FILETTO	FLUJO FLOW FLUSSO
REC24950	35-60494A4	28	1/4"	50 GPH

Bracket de Aluminio. Con 2 tapones de bronce y 1 tubo de extensión.

Cast Aluminium Bracket. With 2 brass plugs & 1 extension tube.  
Supporto in alluminio. Con 2 tappi di bronzo e 1 tubo di estensione.



## KITS FILTROS COMBUSTIBLE FUEL FILTER SET KIT FILTRO BENZINA

Ref.	R.O. OEM
REC35-53336	908034



Ref.	R.O. OEM
REC984491	984491



Ref.	R.O. OEM
REC981911	981911



Ref.	R.O. OEM
REC35-49088A2	312456 381690



Ref.	R.O. OEM
REC982230	982230



Ref.	R.O. OEM
REC1397-2150	983870



## FILTROS ACEITE OIL FILTERS FILTRI OLIO

Ref.	R.O. OEM
REC35-06003	778864

**MOTORES / ENGINES / MOTORI**  
4L GM



Ref.	R.O. OEM
REC35-06007	502900

**MOTORES / ENGINES / MOTORI**  
2.3L, V8, 302, 351



Ref.	R.O. OEM
REC502900	502900

**MOTORES / ENGINES / MOTORI**  
2.3L, V8, 302, 351 Ford



Ref.	R.O. OEM
REC35-06004	173834 502903

**MOTORES / ENGINES / MOTORI**  
V6 GM



Ref.	R.O. OEM
RACS3228UL	173233 502901

**MOTORES / ENGINES / MOTORI**  
V8 GM



Ref.	R.O. OEM
REC3517857	174796 502904

**MOTORES / ENGINES / MOTORI**  
Ford 7.5L / 460



## CARBURADORES CARBURETORS CARBURATORI

Ref.	R.O. OEM
REC1347-818619R02	382733
	980530
	982217
	984180
	381498
	772831

**MOTORES / ENGINES / MOTORI**  
ROCHESTER 2 BB



Ref.	R.O. OEM
REC982217	381668
	980528
	982219
	982217

**MOTORES / ENGINES / MOTORI**  
ROCHESTER 2 BB

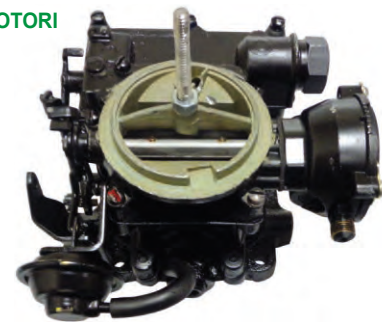

Ref.	R.O. OEM	
REC804624R02	981705	981564
	982223	985822
	983855	981803
	981359	981428
	982215	

**MOTORES / ENGINES / MOTORI**  
ROCHESTER 4 BB



Ref.	R.O. OEM
REC1347-9661A3	382821
	383766
	384194

**MOTORES / ENGINES / MOTORI**  
ROCHESTER 4 BB

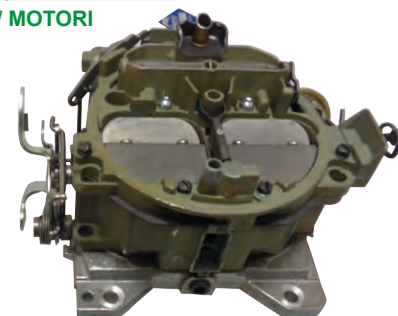
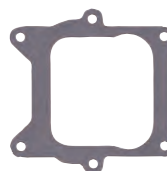



Ref.	R.O. OEM
MP426422	3854087 772846

**MOTORES / ENGINES / MOTORI**  
3.0L (1991-94)  
2.0L HO

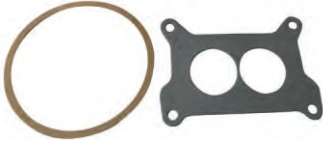
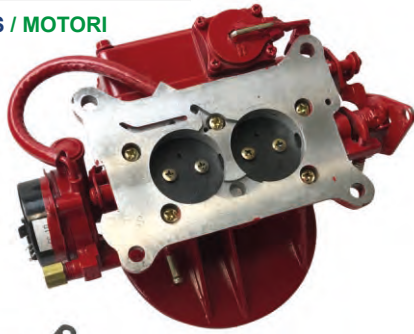

Ref.	R.O. OEM
RM21610333	3854086

**MOTORES / ENGINES / MOTORI**  
3.0L (1995-97)

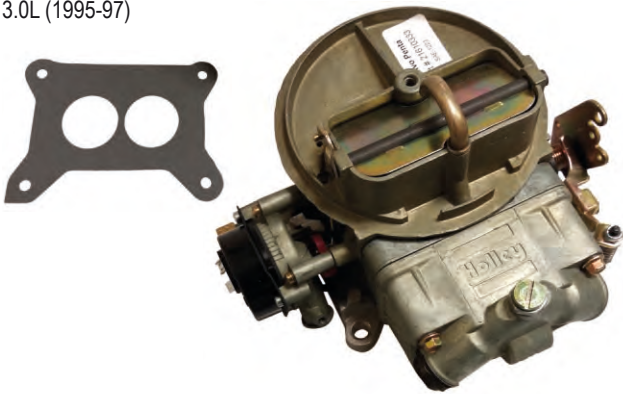

**JUNTAS BASE  
BASE GASKET  
GUARNIZIONE BASE**

Ref.	R.O. OEM
REC315055	315055



Ref.	R.O. OEM
REC27-8079821	909758

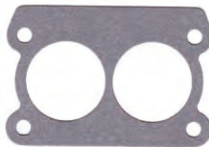

**MOTORES / ENGINES / MOTORI**  
Rochester

Ref.	R.O. OEM
REC3853283	3853283



Ref.	R.O. OEM
REC908765	908765



**KITS CARBURADOR  
CARBURETOR KITS  
KIT CARBURATORE**

Ref.	R.O. OEM
REC1396-5238	982539

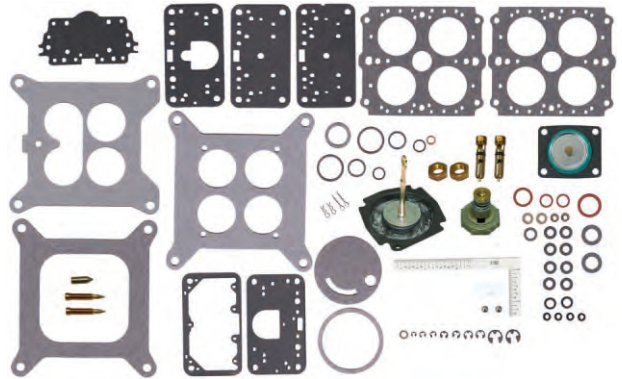

Ref.	R.O. OEM
REC823427A1	982384



Ref.	R.O. OEM
REC1397-5831	508452

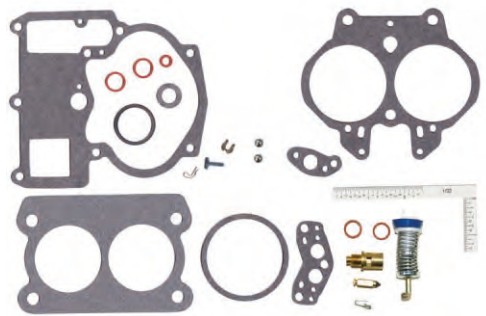

Ref.	R.O. OEM
REC1397-6367A1	508459



Ref.	R.O. OEM
REC823426A1	979659
	384743
	983864
	383918

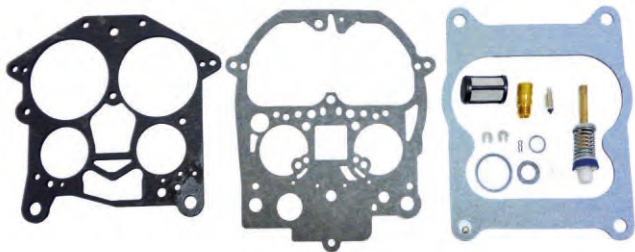

Ref.	R.O. OEM
REC1396-4656	982537
	982538

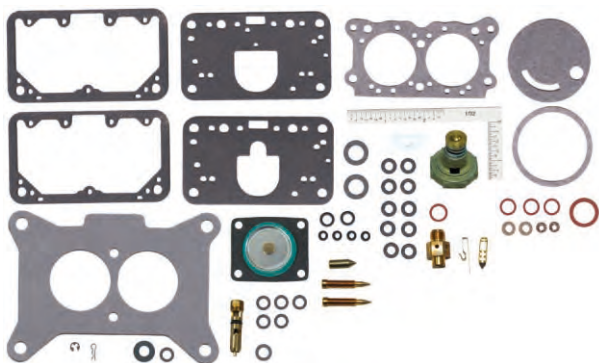

Ref.	R.O. OEM
REC841994	984487
	983073

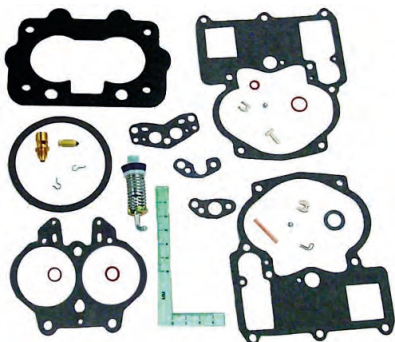

Ref.	R.O. OEM
REC985052	985052



Ref.	R.O. OEM
REC1397-3458	380186



Ref.	R.O. OEM
REC986799	986784
	986799

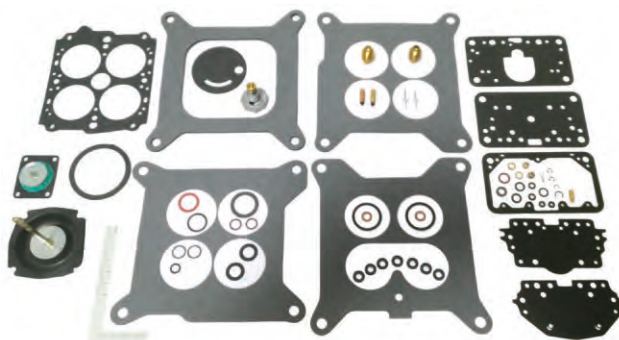

Ref.	R.O. OEM
REC982386	381400
	982386



Ref.	R.O. OEM
REC21533394	987438
	987440
	987485
	21533394

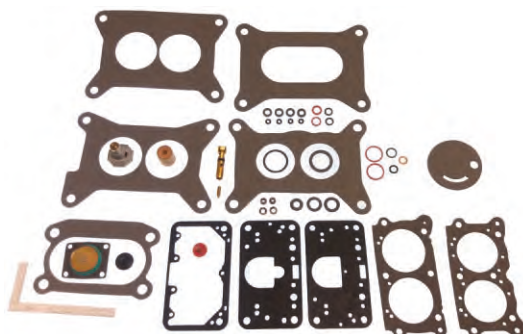

Ref.	R.O. OEM
REC3854105	987313 3854105

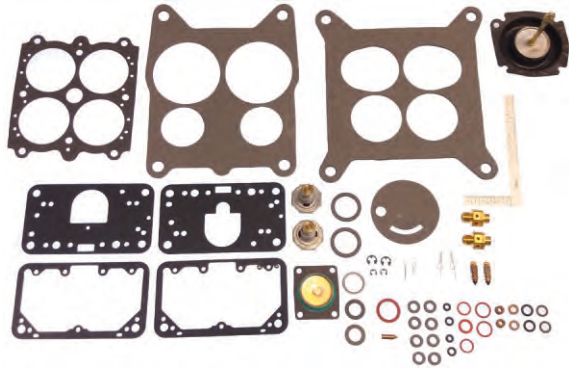

Ref.	R.O. OEM
REC3854020	986796 3854020 3854347

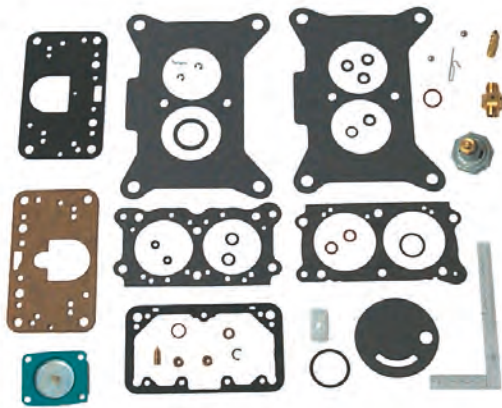

Ref.	R.O. OEM
REC986783	986783



Ref.	R.O. OEM
REC986782	986782

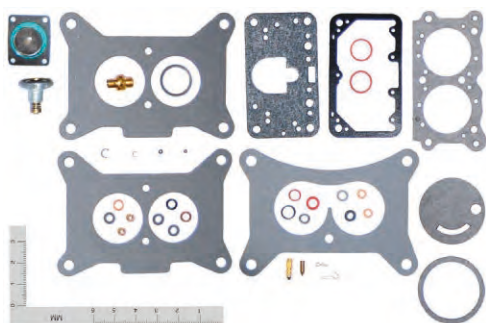

Ref.	R.O. OEM
REC986780	986780



Ref.	R.O. OEM
REC987315	987315

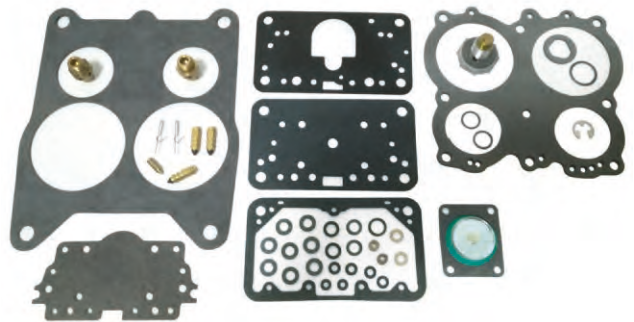

Ref.	R.O. OEM
REC823427A1	982384

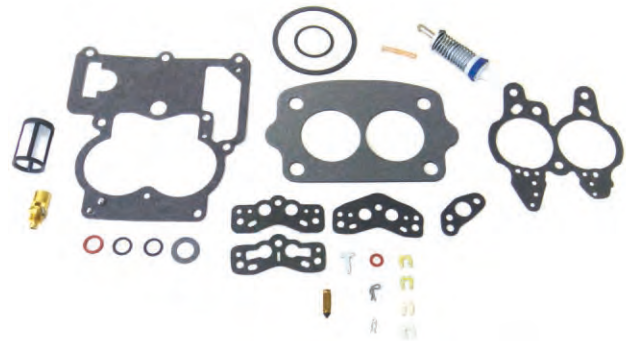

**BOYAS  
FLOATS  
GALLEGGIANTI**

Ref.	R.O. OEM
REC1397-3327	383087 983871



Ref.	R.O. OEM
REC1397-2060	381389



**GUÍA KITS CARBURADOR  
CARBURETOR APPLICATION  
GUIDA CARBURATORE**

Modelo Model Modello	AÑO YEAR ANNO	CÓDIGO CODE CORPI	REF	R.O. OEM
80	1968-69	R2, 2GC	REC1347-818619R02	382733 772831
90	1970-71	R2, 2GC	REC1347-818619R02	382733 772831
120 (400 Series)	1972-86	R2, 2GC	REC982217	381668 980528 982219
140 (400 Series)	1973-85	R2, 2GC	REC982217	979821 980530 982217 984180
155	1967-72	R2, 2GC	REC1347-818619R02	772831
165	1972-76	R2, 2GC	REC1347-818619R02	979821 98053
185	1989	R2, 2GC	REC1347-818619R02	984180
200	1966-68	R2, 2GC	REC1347-818619R02	381494
210	1968-72	R4, 4MV	REC1347-9661A3	382821 383766
215, 225, 230	1971-76	R4, 4MV	REC1347-9661A3	382821
230 (800 Series)	1979-89	R4, 4MV	REC804624R02	981705 982223
245	1972-75	R4, 4MV	REC1347-9661A3	384194

Modelo Model Modello	AÑO YEAR ANNO	CÓDIGO CODE CORPI	REF	R.O. OEM
250	1970-74	R4, 4MV	REC1347-9661A3	384194
260 (800 Series)	1975-76	R4, 4MV	REC1347-9661A3	384194
260 (800 Series)	1979-89	R4, 4MV	REC804624R02	982223
2.5L, 3.0L	1982-86	R2, 2GC	REC982217	982219 982217
3.0L	1987-90	R2, 2GC	REC982217	984180
3.0L	1991-94		MP426422	772846
3.0L	1995-97		RM21610333	3854086
3.8L (4V)	1979-85	R4, 4MV	REC804624R02	983855
4.3L (4V)	1979-89	R4, 4MV	REC804624R02	983855
5.0L (GM)(4V)	1979-89	R4, 4MV	REC804624R02	982223
5.7L (4V)	1979-89	R4, 4MV	REC804624R02	982223
305, 350 CI, I/B,	1977-83	R4, 4MV	REC804624R02	981359 982215 981564 982223
350 (4V)	1988-89	R4, 4MV	REC804624R02	985822
454 CI, I/B	1977-78	R4, 4MV	REC804624R02	981803 981428

**GUÍA KITS CARBURADOR Y BOYAS  
CARBURETOR & FLOATS APPLICATION  
GUIDA KIT CARBURATORE E GALLEGGIANTI**

Modelo Model Modello	AÑO YEAR ANNO	CÓDIGO CODE CORPI	MOD	KIT	BOYAS FLOAT GALLEGGIANT
80	1968-69	R2	2GC	REC823427A1	REC1397-2060
90	1970-71	R2	2GC	REC823427A1	REC1397-2060
100	1972-73	C1	RBS	REC1398-3089	
110	1964	R1	BC	REC1397-3458	
120	1965-71	C1	RBS	REC1398-3089 (2 carb)	
120	1972-85	R2	2GC	REC982386	REC1397-2060
140	1973-85	R2	2GC	REC823427A1	REC1397-2060
150	1964-65	R1	BC	REC1397-3458	
155	1967-72	R2	2GC	REC982386	
165	1972-76	R2	2GC	REC823427A1	REC1397-2060
170	1974	H2	2300	REC1396-4656	
175	1975-77	H2	2300	REC1396-4656	
185	1978-81	R2	2GE	REC841994	REC1397-2060
185	1989	H2	2300	REC1396-4656	
190	1974-77	H2	2300	REC1396-4656	
200	1966-68	R2	2GC,V	REC982386	
200	1979-85	R2	2GE	REC841994	REC1397-2060
200	1989	H2	2300	REC1396-4656	
210	1968-72	R4	4MV	REC823426A1	REC1397-3327
215	1971	R4	4MV	REC823426A1	REC1397-3327
225	1972-76	R4	4MV	REC823426A1	REC1397-3327
230	1975-76	R4	4MV	REC823426A1	REC1397-3327
230	1979-89	R4	4MV	REC823426A1	REC1397-3327
235	1975-77	H4	4160	REC1396-5238	
235	1989	H4		REC985052	
240	1978	H4		REC985052	
245	1972-75	R4	4MV	REC823426A1	REC1397-3327
250	1970-74	R4	4MV	REC823426A1	REC1397-3327
250	1979	H4		REC985052	
260	1975-76	R4	4MV	REC823426A1	REC1397-3327
260	1979-89	R4	4MV	REC823426A1	REC1397-3327
290 JET	1974-75	R4	4MV	REC823426A1	REC1397-3327
2.3 L	1987-89	R2	2GE	REC841994	REC1397-2060

Modelo Model Modello	AÑO YEAR ANNO	CÓDIGO CODE CORPI	MOD	KIT	BOYAS FLOAT GALLEGGIANT
2.5L	1982-85	R2	2GC	REC982386	REC1397-2060
2.5L	1986-90	R2	2GE	REC841994	REC1397-2060
2.5L	1986	R2	2GC	REC823427A1	REC1397-2060
3.0L	1982-90	R2	2GC	REC823427A1	REC1397-2060
3.0L/HO	1991-92	H2	2300	REC21533394	
3.8L	1979-85	R2	2GE	REC841994	REC1397-3327
4.3L	1986-89	R2	2GE	REC841994	REC1397-2060
4.3L	1979-89	R4	4MV	REC823426A1	REC1397-3327
4.3/262	1989	R2	2GE	REC841994	REC1397-2060
4.3 HO	1990-92	H2	2300	REC3854020	
4.3HO	1990-92	H4	4160	REC986799	
5.0L (GM)	1979-85	R2	2GE	REC841994	REC1397-2060
5.0L (GM)	1979-89	R4	4MV	REC823426A1	REC1397-3327
5.0L (Ford)	1989	H2	2300	REC1396-4656	
5.0 HO	1989-90	H2	2300	REC986782	
5.0 HO	1989-90	H4	4160	REC986799	
5.0 HO	1991	H4	4160	REC1396-5238	
5.7L	1979-89	R4	4MV	REC823426A1	REC1397-3327
5.7L	1990-92	H4	4175	REC986780	
5.7LE	1990	H4	4175	REC986780	
5.7LE	1991-92	H4	4175	REC987315	
5.8L	1989	H4		REC985052	
7.5L	1987-88	H4		REC985052	
305 C.I.I./B	1977-79	R2	2GE	REC841994	REC1397-2060
305 C.I.I./B	1977-78	R4	4MV	REC823426A1	REC1397-3327
305 C.I.I./B	1979-83	R4	4MV	REC823426A1	REC1397-3327
305 C.I.I./B	1979-83	R4	4MV	REC823426A1	REC1397-3327
350	1988-89	R4	4MV	REC823426A1	REC1397-3327
350	1988	R2	2GE	REC841994	REC1397-2060
454 C.I.I./B	1977-78	R4	4MV	REC823426A1	REC1397-3327
454 HO	1991-92	H4	4150	REC3854105	
460 C.I.	1987-88	H4	-	REC985052	
460	1989-90	H4	4160	REC986783	

## SENSORES SENSORS SENSORI

### TEMPERATURA AGUA WATER TEMPERATURE TEMPERATURA ACQUA

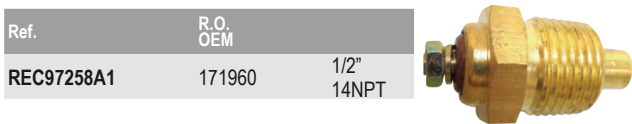

### KIT TEMPERATURA Y PRESIÓN DE ACEITE CON ALARMA COMPLETE TEMPERATURE & OIL PRESSURE WARNING KIT KIT TEMPERATURA PRESSIONE DELL'OLIO CON ALLARME



### TEMPERATURA AIRE AIR TEMPERATURE TEMPERATURA ARIA



### PRESIÓN DE ACEITE OIL PRESSURE PRESSIONE DELL'OLIO

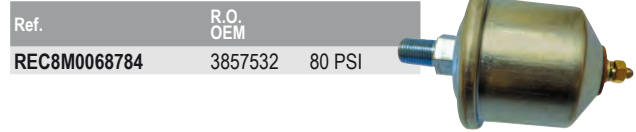

### VACUÓMETRO. MAP MAP SENSOR. MAP VACUOMETRO. MAP



### SENSOR TPS TPS SENSOR SENSORE TPS



## ENCENDIDO IGNITION ACCENSIONE

### TAPAS DISTRIBUIDOR DISTRIBUTOR CAPS CALOTTE SPINTEROGENI

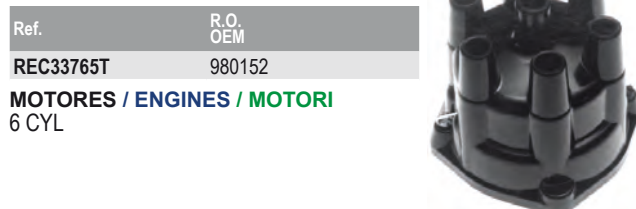
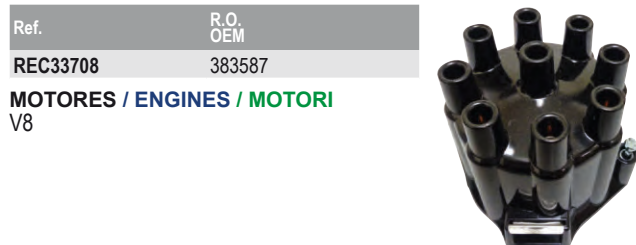
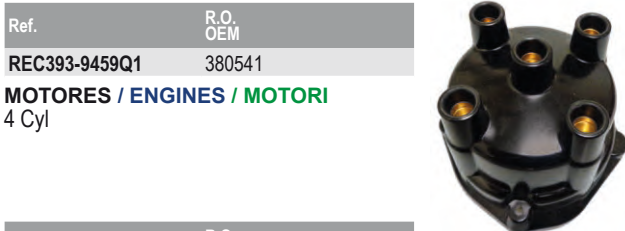

Ref.	R.O. OEM
REC3854217	3854217

**MOTORES / ENGINES / MOTORI**  
V8 EFI



Ref.	R.O. OEM
REC982209	982209

**MOTORES / ENGINES / MOTORI**  
MALLORY V8



Ref.	R.O. OEM
REC835702	982336

**MOTORES / ENGINES / MOTORI**  
PRESTOLITE V8  
Con clip / Clip on / Con clip



Ref.	R.O. OEM
REC392-9086T	3853814

**MOTORES / ENGINES / MOTORI**  
PRESTOLITE V6



Ref.	R.O. OEM
REC392-9766	3853815

**MOTORES / ENGINES / MOTORI**  
PRESTOLITE V8  
Con tornillo / Screw on / con vite



Ref.	R.O. OEM
REC3854260	3854260

**MOTORES / ENGINES / MOTORI**  
4 cly



Ref.	R.O. OEM
REC3854331	3854331

**MOTORES / ENGINES / MOTORI**  
DELCO V6  
Encendido electrónico / Electronic ignition /  
Accessione elettronico



Ref.	R.O. OEM
REC3854548	3854548

**MOTORES / ENGINES / MOTORI**  
DELCO V8  
Encendido electrónico / Electronic ignition /  
Accessione elettronico



Ref.	R.O. OEM
REC985218	985218

**MOTORES / ENGINES / MOTORI**  
MALLORY 4 CIL.



## PLATINO POINT PUNTINE

Ref.	R.O. OEM
REC34235T	380538

**MOTORES / ENGINES / MOTORI**  
DELCO 4 & 6 CIL.



Ref.	R.O. OEM
REC33700	380543

**MOTORES / ENGINES / MOTORI**  
DELCO V8



Ref.	R.O. OEM
REC391-5090	382135

**MOTORES / ENGINES / MOTORI**  
MALLORY V8



Ref.	R.O. OEM
REC8M6001219	980893 987136 987894

**MOTORES / ENGINES / MOTORI**  
PRESTOLITE V6 & V8



## CONDENSADORES CONDENSERS CONDENSATORE

Ref.	R.O. OEM
REC8M6001217	382136 382125

**MOTORES / ENGINES / MOTORI**  
MALLORY & DELCO V8



Ref.	R.O. OEM
REC8M6001249	987895

**MOTORES / ENGINES / MOTORI**  
PRESTOLITE V6 & V8



Ref.	R.O. OEM
REC33662	380537

**MOTORES / ENGINES / MOTORI**  
DELCO 4 & 6 CIL.



**ROTORES  
ROTORS  
ROTORI**

Ref.	R.O. OEM
REC3853801	3853801

**MOTORES / ENGINES / MOTORI**  
PRESTOLITE  
V6 & V8



Ref.	R.O. OEM
REC834975	980892

**MOTORES / ENGINES / MOTORI**  
PRESTOLITE V8  
Con clip / Clip on / Con clip



Ref.	R.O. OEM
REC3854261	3854261

**MOTORES / ENGINES / MOTORI**  
DELCO 4 CIL



Ref.	R.O. OEM
REC89825302	982211

**MOTORES / ENGINES / MOTORI**  
MALLORY V8



Ref.	R.O. OEM
REC841243	982342

**MOTORES / ENGINES / MOTORI**  
MALLORY V8  
Plano / Flat / piatto



Ref.	R.O. OEM
REC58217	384735

**MOTORES / ENGINES / MOTORI**  
DELCO 4 & 6 CIL.



Ref.	R.O. OEM
REC3854549	

**MOTORES / ENGINES / MOTORI**  
DELCO V6



Ref.	R.O. OEM
REC3854311	

**MOTORES / ENGINES / MOTORI**  
DELCO V8  
Encendido electrónico / Electronic ignition /  
Accessione elettronico



**KITS DE ENCENDIDO  
TUNE UP KITS  
KIT ACCENSIONE**

Ref.	R.O. OEM
REC801766	



Ref.	R.O. OEM
REC392-6325Q1	



REC834975 + REC8M6001219 + REC8M6001249

Ref.	R.O. OEM
REC391-5090Q1	



REC89825302 + REC391-5090 + REC8M6001217

Ref.	R.O. OEM
REC3423A1	



REC58217 + REC34235T + REC33662

Ref.	R.O. OEM
REC392-6324Q1	



REC3853801 + REC8M6001219 + REC8M6001249

## DISTRIBUIDORES DISTRIBUTORS SPINTEROGENI

Ref. R.O. OEM

REC195141

MOTORES / ENGINES / MOTORI  
GM 4 CIL.

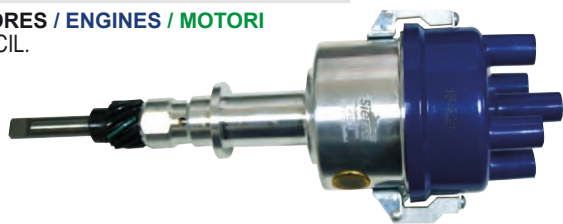

Ref. R.O. OEM

REC17177A1 17177A1

MOTORES / ENGINES / MOTORI  
GM V8



Ref. R.O. OEM

REC392-6316

MOTORES / ENGINES / MOTORI  
FORD 302 CID V8



Ref. R.O. OEM

REC392-6330 985764

MOTORES / ENGINES / MOTORI  
FORD 351 CID V8



## KITS DE CONVERSIÓN ELECTRÓNICO ELECTRONIC CONVERSION KITS KIT CONVERSIONE ELETTRONICO

- Sustituyen condensadores y contactos por componentes electrónicos.
- Usa bobina, tapa y rotor estandar.
- De fácil instalación, una pieza y dos cables.
- Precisión entre 1/4" calibrado de 0 a 8000 rpm.
- To substitute condensers for electronic devices
- Uses standard.coil, cap & rotor
- Easy installation; one piece, two cables.
- Precisely calibrated between 1/4" from 0 to 8000
- Sostituisc condensatori e contatti per componenti elettronici.
- Utilizza bobina, calotta e rotore standard.
- Facile installazione, un pz e due cavi.
- Precisione 1/4" calibrato da 0 a 8000.

Ref. R.O. OEM

REC26904

MOTORES / ENGINES / MOTORI

Para la mayoría de distribuidores de 8 cil.  
Mallory YL o YD con rotación  
reloj y contrareloj.  
For most Mallory V8  
distributors

Per al maggior parte degli  
spinterogeni per 8 cilindri  
Mallory YL o YD con  
rotazione oraria e antioraria



Ref. R.O. OEM

REC26902

MOTORES / ENGINES / MOTORI

Para la mayoría de distribuidores  
Prestolite V8 con tornillo en la tapa  
For most Prestolite V8 distributors  
with screw on cap

Per al maggior parte degli  
spinterogeni Prestolite V8 con vite  
nella calotta.



Ref. R.O. OEM

REC26901

MOTORES / ENGINES / MOTORI

Para la mayoría de distribuidores de 6  
cilindros Delco.  
For most Delco 6 cyl. distributors

Per al maggior parte degli spinterogeni  
per 6 cilindri Delco.



Ref. R.O. OEM

REC26903

MOTORES / ENGINES / MOTORI

Presolite V8



Ref. R.O. OEM

REC26900

MOTORES / ENGINES / MOTORI

GM 4 cyl





## MÓDULO ENCENDIDO IGNITION MODULE MODULO ACCENSIONE

Ref.	R.O. OEM
REC3854001	3854001 986642

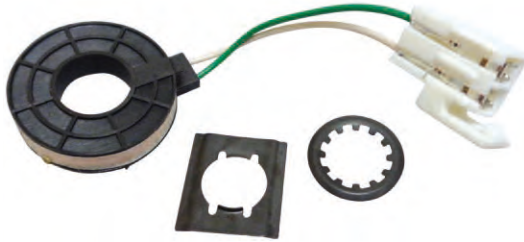

Ref.	R.O. OEM
REC3854003	3854003 986650

**MOTORES / ENGINES / MOTORI**  
4L, V8



## BOBINAS ENCENDIDO IGNITION COILS BOBINE ACCENSIONE

Ref.	R.O. OEM
REC300-00879	3852217

No usa resistencia externa.  
Utilizar con encendido Prestolite.  
Use without external resistor & Prestolite  
ignition  
Non utilizza resistenza esterna. Utilizzare con  
spinterogeno Prestolite



Ref.	R.O. OEM
REC1463-9382	3853548

Resistencia externa.  
Utilizar con encendido convencional.  
External resistor. Use with conventional  
ignition  
Resistenza esterna. Utilizzare con accensione  
convvenzionale



Ref.	R.O. OEM
REC3854161	3854161

**MOTORES / ENGINES / MOTORI**  
FORD



Ref.	R.O. OEM
REC3854002	3854002

**MOTORES / ENGINES / MOTORI**  
GM

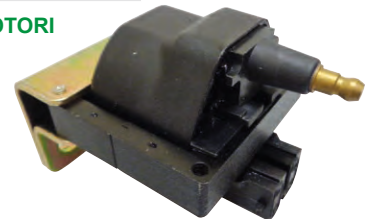

## GUÍA BOBINAS ENCENDIDO IGNITION COIL GUIDE GUIDA BOBINE ACCENSIONE

Año Year Anno		Ref
94-93	351 EFI King	REC3854161
	5.0L, 5.8L EFI	REC3854161
94-90	3.0L, 3.0L H.O.	REC3854002
94-89	5.0L, 5.0L H.O., 5.8L	REC1463-9382
	5.7L	REC1463-9382
94	7.4L	REC1463-9382
93-92	454, 454 H.O., 502	REC1463-9382
93	351 King	REC1463-9382
92-91	5.7L w/Electronic Ign.	REC1463-9382
92-90	5.7LE OMC Cobra (w/Conv. Ign.)	REC1463-9382
92	351	REC1463-9382
91-90	4.3L, 4.3L H.O. (2V Models)	REC1463-9382
90-87	2.3L	REC1463-9382
90	3.0L (PWC)	REC1463-9382
89-88	350 OMC King Cobra	REC1463-9382
	460 OMC King Cobra	REC1463-9382

Año Year Anno		Ref
89-85	2.5L, 3.0L, 4.3L Eng.	REC1463-9382
88-86	5.0L, 5.7L	REC1463-9382
88	370 OMC King Cobra	REC1463-9382
	335 OMC Cobra	REC1463-9382
87	340 OMC King Cobra	REC1463-9382
	7.5L	REC1463-9382
84-80	120, 140, 185, 200, 230, 260 HP	REC1463-9382
79	120, 140, 185, 200, 230, 250, 260 HP	REC1463-9382
78	120, 140, 185, 225, 230, 240, 305, 350, 454HP	REC1463-9382
77	120, 140, 175, 190, 225, 230, 235 HP	REC1463-9382
76	120, 140, 165, 175, 190, 225, 230, 235 HP	REC1463-9382
75	120, 140, 165, 175, 190, 225, 230, 235, 245,	REC1463-9382
74	120, 140, 165, 225, 245, 250, 290 HP	REC1463-9382
73	100, 120, 140, 165, 225, 245, 250 HP	REC1463-9382
72	100, 120, 155, 165, 210, 225, 245, 250 HP	REC1463-9382
71	90, 120, 155, 210, 215, 235, 250 HP	REC1463-9382

# BUJÍAS SPARK CANDELE

Año Year Anno	Modelo Model Modello	CHAMPION	NGK
1990-87	2.3L Cobra	CHARS12YC	NGKTR5
1996	3.0L SX Cobra	CHARS12YC	NGKTR5
1995-90	3.0L Cobra HO	CHARS12YC	NGKTR5
1994-93	3.0L Cobra	CHARS12YC	NGKTR5
1992-87	3.0L Cobra	CHARV15YC4	NGKUR4
1996 (.460»)	4.3L SX Cobra	CHARV15YC4	NGKUR4
1996 (.708»)	4.3L SX Cobra	CHARS12YC	NGKTR5
1995-86	4.3L Cobra	CHARV15YC4	NGKUR4
1991-90	4.3L Cobra HO	CHARV15YC4	NGKUR4
1994-93	4.3L Cobra HO	CHARV15YC4	NGKUR4
1996 (Carb.)	5.0L SX Cobra	CHARV15YC4	NGKUR4
1996 (EFI)	5.0L SX Cobra	CHARS12YC	NGKTR5
1995-96 (Carb.)	5.0L Cobra	CHARV15YC4	NGKUR4
1995-89 (Carb.)	5.0L Cobra HO	CHARV15YC4	NGKUR4
1995-94	5.0L Cobra EFI	CHARS12YC	NGKTR5

Año Year Anno	Modelo Model Modello	CHAMPION	NGK
1993	5.0L Cobra EFI	CHARV15YC4	NGKUR4
1996	5.7L SX Cobra	CHARV15YC4	NGKUR4
1992-86	5.7L King Cobra	CHARV15YC4	NGKUR4
1996 (Carb.)	5.8L SX Cobra	CHARV15YC4	NGKUR4
1996 (EFI)	5.8L SX Cobra	CHARS9YC	NGKTR5
1995-89 (Carb.)	5.8L Cobra	CHARV15YC4	NGKUR4
1995-92 (EFI)	5.8L Cobra	CHARS9YC	NGKTR5
1995-93 (EFI-HO)	5.8L King Cobra	CHARS9YC	NGKTR5
1996	7.4L SX Cobra	CHARV15YC4	NGKUR4
1995-90 (Carb.)	7.4L SX Cobra	CHARV15YC4	NGKUR4
1995 (EFI)	7.4L King Cobra	CHARV15YC4	NGKUR4
1993-91 (Carb.)	7.4L Cobra HO	CHARV15YC4	NGKUR4
1990-86	7.5L Cobra	CHARV15YC4	NGKUR4
1996	8.2L SX Cobra	CHARV15YC4	NGKUR4
1994-92	8.2L King Cobra	CHARV15YC4	NGKUR4

## JUEGOS DE CABLE PARA BUJÍAS DE ALTO RENDIMIENTO HD SPARK PLUG WIRE SET KIT CAVI CANDELE ALTE PRESTAZIONI

- Núcleo del cable de Kevlar de 8 mm antimagnético
- Funda de silicona amarilla
- Terminales bujías con muelle de acero inox
- Terminal del Distribuidor de Cobre
- Terminales Bobina
- Silicona resistente a altas temperaturas
- Garantía de 5 años

- Antimagnetic Kevlar core
- Yellow silicone boot & jacket
- SS snaplock
- Brass distributor terminal
- Coil terminals
- High resistant silicone
- 5 year warranty

- Nucleo dei cavi in Kevlar da 8 mm antimagnetico
- Fodera in silicone gialla
- Terminali candele con molle di acciaio inox.
- Terminale lato spinteorgeno in rame
- Terminali Bobina
- Silicone resistente alle alte temperature
- Garanzia 5 anni

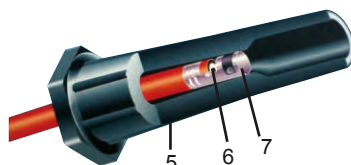
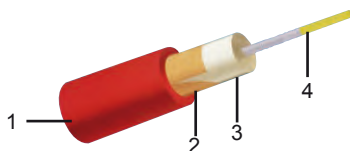

Nº	Descripción	Description	Descrizione
1	Camisa de silicona de 8 mm.	8 mm silicone jacket	Guaina in silicone da 8 mm
2	Latex resistente altas temperaturas	heat resistant latex	Latex resistente alle alte emperature
3	Acero inox	Stainless Steel	Acciaio inox
4	Núcleo de Kevlar	Kevlar core	Nucleo de Kvlar
5	Capuchón de silicona	silicone jacket	Capuccio in silicone
6	Trenzado fibra	Fiberglass braiding	Fibra di vetro
7	Terminal de acero inox	Stainless Steel terminal	Terminale in acciaio inox

Ref	R.O. OEM	MODELO MODEL MOELLO	ARRANQUE CONVENCIONAL IGNITION CONVENTIONAL AVVIAMENTO CONVENZIONALE	ARRANQUE ELECTRONICO IGNITION ELECTRONIC AVVIAMENTO ELETTRONICO	CYL
REC15-401		110 / 120 / 2.5L / 140 / 3.0L / 140 JET	✓		4
REC15-405	503748	3.0L / HO		✓	4
REC15-602	503748	185 (6 en línea / in line / in rete)	✓		6
REC15-604		3.8 L / 4.3 L (229, 262) V6	✓		6
REC15-601	503750	4.3L (262) V6		✓	6
REC15-801	503751	175 / 185 / 190 / 20 / 5.0 L - 5.7 L / (GM)	✓		8
REC15-806		(Tapas de terminal Mallory / Mallory ends caps models / Coperchio terminali Mallory)	✓		
REC15-806	503752 503755	5.0 L - 5.8 L (FORD)	✓		8
REC15-805	503753	5.0 L - 5.8 L - EFI (FORD)		✓	8
REC15-801	503754	225 / 230 / 235 / 240 / 250 / 260	✓		8
REC15-806		(Tapas de terminal Mallory / Mallory ends caps models / Coperchio terminali Mallory)	✓		
REC15-801	503752 503755	370 KING / 454 / 7.4 L / 502 / 8.2 L	✓		8
REC15-811	503752 503755	460 KING	✓		8

## MÓDULO SISTEMA CAMBIO SHIFT ASSIST MODULE MODULO SISTEMA CAMBIO

Ref.	R.O. OEM	CYL
REC987739	982755	4
	984281	
	985902	
	982774	
	984036	
	986342	6
	987740	
	982749	
	984276	
	984730	
986837		
987738		
987739		



## MOTORES DE ARRANQUE STARTERS MOTORINO D'AVVIAMENTO

Ref.	R.O. OEM		DIENTES TOOTH DENTI
PH140-0013	982121	12V	9
	981078		
	988217		

**MOTORES / ENGINES / MOTORI**  
Motor de arranque 4 en línea  
(Tornillos sujeción misma altura)  
Duty standard rotation 4 in line.  
In line mounting holes.  
4 in linea (viti di supporto parallele)



Ref.	R.O. OEM		DIENTES TOOTH DENTI
PH140-0022	981289	12V 1.4 Kw	9
	982202		



Ref.	R.O. OEM		DIENTES TOOTH DENTI
PH140-0005	984628	12V	10

**MOTORES / ENGINES / MOTORI**  
FORD 2.3L & 5.8L  
Con 3 tornillos de anclaje.  
3 mounting holes.  
Con 3 viti di supporto

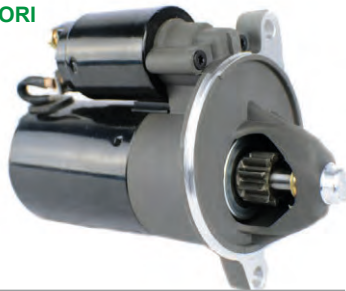

Ref.	R.O. OEM		DIENTES TOOTH DENTI
PH140-0022-CCW	981288	12V 1.4 Kw	9
	984982		

**MOTORES / ENGINES / MOTORI**  
Contrarrotación o montaje en campana.  
Counter clockwise starter  
Controrotante montato nella campana.

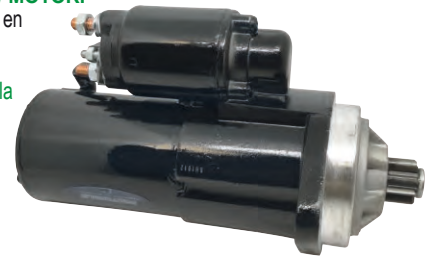

Ref.	R.O. OEM		DIENTES TOOTH DENTI
PH140-0006	984536	12V	10
	988013		

**MOTORES / ENGINES / MOTORI**  
OMC 460 COBRA

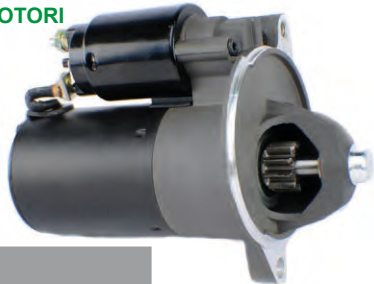

Ref.	R.O. OEM		DIENTES TOOTH DENTI
PH140-0004	987811	12V	10
	3854190		

**MOTORES / ENGINES / MOTORI**  
Ford 5.0L & 5.8L  
Con 2 tornillos de anclaje  
2 mounting holes  
Con 2 viti di supporto

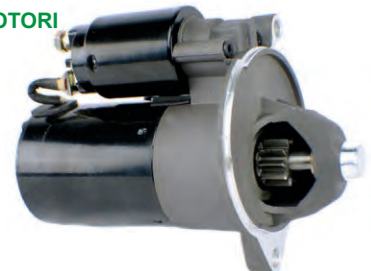

Ref.	R.O. OEM
PH375-0009	3854194

**MOTORES / ENGINES / MOTORI**  
Solenoid  
Solenoid  
Solenoid.



Ref.	R.O. OEM	DIENTES TOOTH DENTI
PH140-0004-CCW		12V 10

**MOTORES / ENGINES / MOTORI**  
 Contrarrotación.  
 Counter clockwise starter  
 Controrrotante.

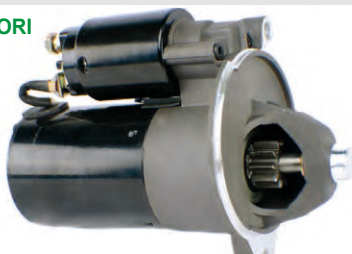

Ref.	R.O. OEM	DIENTES TOOTH DENTI
PH140-0017-D	3860566	12V 1.4 Kw 11

**MOTORES / ENGINES / MOTORI**  
 V6 & V8  
 Con volante de 14"  
 14" flywheel  
 Con volano da 14"

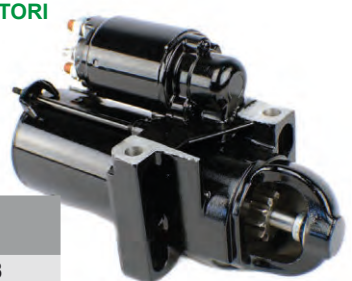

TORNILLO BOLT VITE	R.O. OEM
REC10-861788	10-861788



Ref.	R.O. OEM	DIENTES TOOTH DENTI
PH140-0015	3860566	12V 9

**MOTORES / ENGINES / MOTORI**  
 Tornillos sujeción en diagonal  
 Offset mounting holes  
 Con viti in diagonale



TORNILLO BOLT VITE	R.O. OEM
MP0180-001	
REC10-861788	10-861788





Ref.	R.O. OEM	DIENTES TOOTH DENTI
PH140-0020	988217	12V 9

**MOTORES / ENGINES / MOTORI**  
 COBRA 3.0 L  
 Volante de 12 3/4"  
 With 12 3/4" flywheel  
 Con volano de 13 3/4"



TORNILLO BOLT VITE	R.O. OEM
MP0180-001	
REC10-861788	10-861788





Ref.	R.O. OEM	DIENTES TOOTH DENTI
PH140-0017-HT		12V 11

**MOTORES / ENGINES / MOTORI**  
 HEAVY DUTY. GM 454 7.4L  
 Fijación en diagonal  
 with diagonally fixation screws.  
 Con viti in diagonale



TORNILLO BOLT VITE	R.O. OEM
REC10-861788	10-861788



**ALTERNADORES  
ALTERNATORS  
ALTERNATORI**

Ref.	R.O. OEM	12V 63A
PH300-0007	985964	

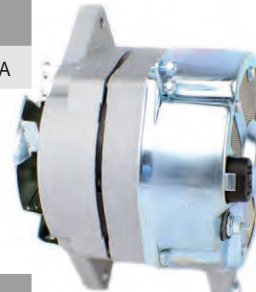

Ref.	R.O. OEM	12V 63A
PH300-0013	988247	



Ref.	R.O. OEM	12V 55A
PH300-0010	986008 985964	



**RELÉ  
RELAYS  
RELE**

**RELÉ BOMBA GASOLINA ELÉCTRICA  
RELAY FOR FUEL ELECTRIC PUMP  
RELE POMPA BENZINA ELETTRICA**

Ref.	R.O. OEM
REC3857533	3857533



**REGULADOR  
REGULATOR  
REGOLATORE**

Ref.	R.O. OEM
ARCVR-404	383440

**MOTORES / ENGINES / MOTORI  
PRESTOLITE**



**SOLENOIDES  
SOLENOID  
SOLENOIDE**

Ref.	R.O. OEM
PH375-0001	1114356 11143589

DELCO REMY



Ref.	R.O. OEM
PH375-0027	982187 985063
PH375-0030	979774
PH375-0012	383622 582708 345419 586180



PH375-0027



PH375-0030



PH375-0012

**TRIM**

**MOTOR TRIM  
TRIM MOTOR  
MOTORE TRIM**

Ref.	R.O. OEM	CABLES WIRES CAVI
PH200-T014	393259	2
	393988	
	394176	
	391264	
	983019 985237	



Ref.	R.O. OEM	CABLES WIRES CAVI
PH200-T020	387277	3
	582048	
	582155	



Ref.	R.O. OEM	CABLES WIRES CAVI
PH200-T023	986280	2
	3853945	

**MOTORES / ENGINES / MOTORI  
COBRA (1987-93)**



Ref.	R.O. OEM	CABLES WIRES CAVI
PH200-T009	982058	3
	982706	



Ref.	R.O. OEM	CABLES WIRES CAVI
REC382138	382138	2



Ref.	R.O. OEM	CABLES WIRES CAVI
ARC6211	983318	3

**MOTORES / ENGINES / MOTORI**  
2.5L, 3.0L (1979-85)

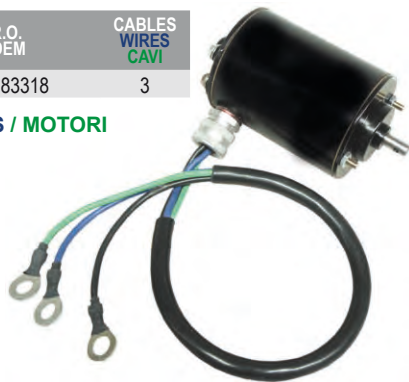

**LATIGUILLOS TRIM  
TRIM HOSES  
TUBI TRIM  
COBRA**

**BAJADA ESTRIBOR  
STBD. DOWN  
DISCESA TRIBORDO**

Ref.	R.O. OEM
REC3853854	3853854



**BAJADA BABOR  
PORT DOWN  
DISCESA BABORDO**

Ref.	R.O. OEM
REC3853856	3853856



**SUBIDA ESTRIBOR  
STBD. UP  
SALITA TRIBORDO**

Ref.	R.O. OEM
REC3853855	3853855



**SUBIDA BABOR  
PORT UP  
SALITA BABORDO**

Ref.	R.O. OEM
REC3853857	3853857



**UNIDADES DE TRANSMISIÓN  
UNIT DRIVES  
UNITÀ DI TRASMISSIONE**



**KIT CONVERSIÓN OMC-COBRA  
CONVERSION KIT OMC-COBRA  
KIT CONVERSIONE OMC - COBRA**

Ref.	R.O. OEM
REC9D-116	



Kit para adaptar las colas Mercruiser a las antiguas unidades OMC-Cobra hasta 300 HP, con el cambio en la unidad inferior. Fácil instalación.  
This kit will work on Cobra drives up to 300 HP.

Easy to replace the aging Cobra drives with a current style drive that has readily available spare parts.

Kit per adattare i piedi Mercruiser alle vecchie unità OMC-Cobra fino a 300 HP, con il cambio nella unità inferiore. Facile installazione.

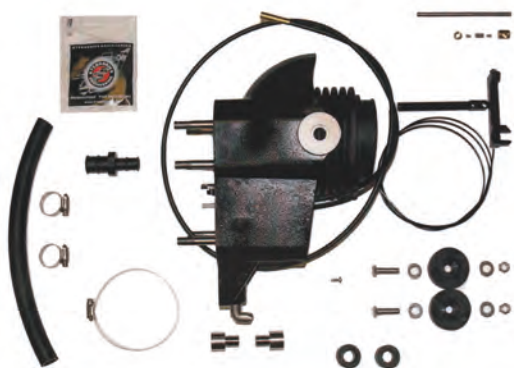

Cola no incluida.  
Stern Drive not included  
Piede no inclosco

**PARTE INFERIOR COMPLETA  
GEAR HOUSING ASSEMBLY  
PARTE INFERIORE COMPLETA  
COBRA (1986-93)**

Ref.	R.O. OEM
REC987800	987800

**MOTORES / ENGINES / MOTORI**  
3.0, 4.3, 5.0, 5.7 & 5.8L

Reducción / Ratio / Riduzione: 12:22



**PARTE SUPERIOR  
UPPER GEARCASE  
PARTE SUPERIORE  
COBRA (1986-93)**

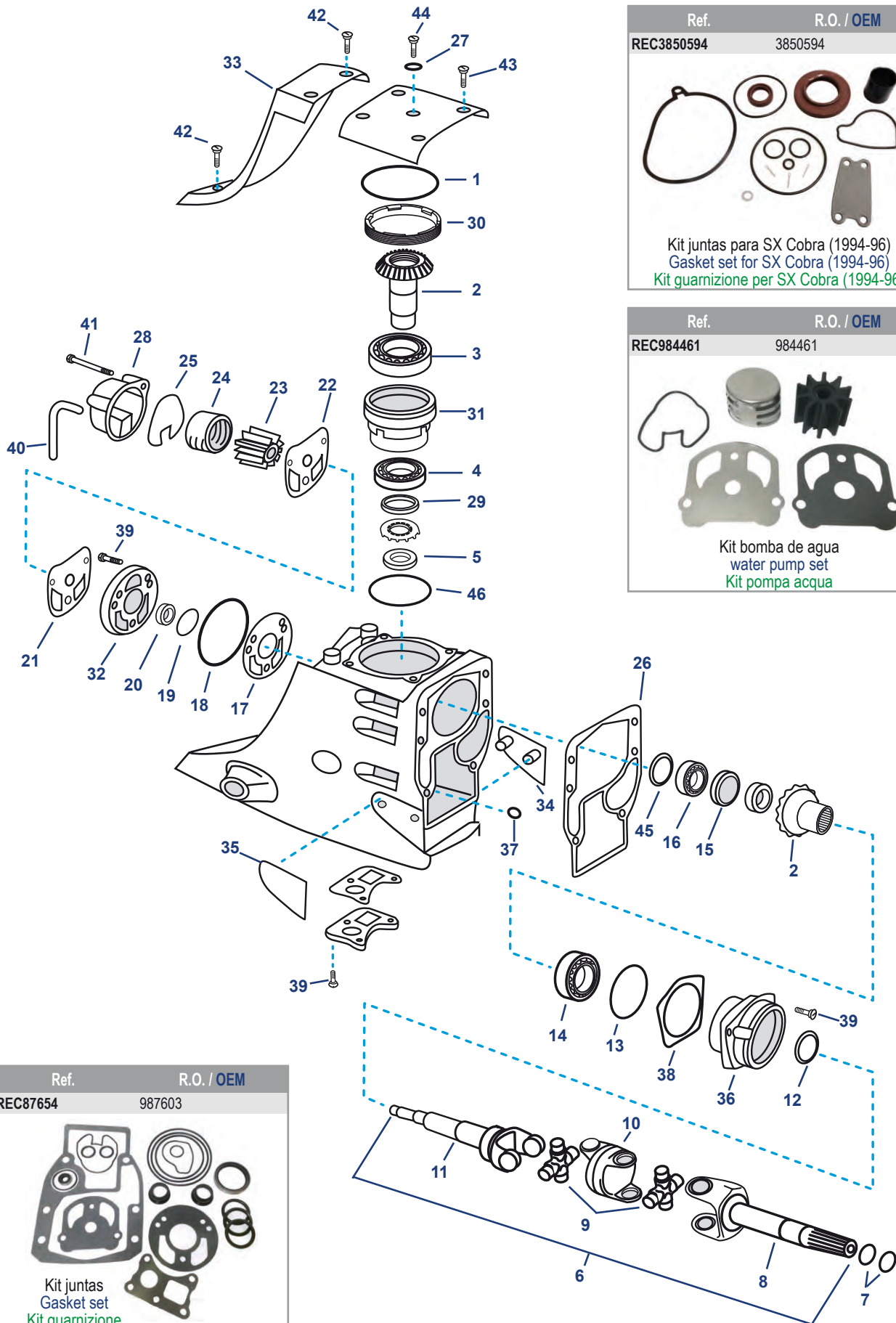

Ref.	R.O. / OEM
REC3850594	3850594

Kit juntas para SX Cobra (1994-96)  
Gasket set for SX Cobra (1994-96)  
Kit guarnizione per SX Cobra (1994-96)

Ref.	R.O. / OEM
REC984461	984461

Kit bomba de agua  
water pump set  
Kit pompa acqua

Ref.	R.O. / OEM
REC87654	987603

Kit juntas  
Gasket set  
Kit guarnizione  
(1986-93)

Nº	Ref.	R.O. OEM	Descripción	Description	Descrizione
1	REC313175	313175	ARO TÓRICO	O-RING	ANELLO
2	REC983825	983825	KIT PIÑONES (21:16) V8	GEAR SET	KIT PIGNONE
2	REC984012	984012	KIT PIÑONES (21:19) V6	GEAR SET	KIT PIGNONE
2	REC983826	983826	KIT PIÑONES (21:18) V8	GEAR SET	KIT PIGNONE
3	REC31-35990A1	983891	COJINETE	BEARING	CUSCINETTO
4	REC983892	983892	COJINETE	BEARING	CUSCINETTO
5	REC911753	911753	TUERCA PIÑÓN	PINION NUT	DADO
6	REC983880	983880	CARDÁN COMPLETO	U-JOINT & WATER PUMP SHAFT	CARDANO COMPLETO
7	REC25-25439	3852565	ARO TÓRICO	O-RING	ANELLO
8	REC59830A7	912212	UNIÓN COLA MOTOR	YOKE-DRIVE SHAFT	UNIONE MOTORE
9	REC3850812	3850812	CRUCETA CARDAN 1990-93	UNIVERSAL JOINT	CROCETTA CARDANO (1990-93)
9	REC75832T	912214	CRUCETA CARDAN 1986-99	UNIVERSAL JOINT	CROCETTA CARDANO (1986-99)
10	REC393831	912213	CARDAN	SOCKET	CARDANO
11	REC984264	984264	EJE BOMBA AGUA	YOKE & WATER PUMP SHAFT	ASSE POMPA ACQUA
12	REC911685	911685	RETÉN	OIL SEAL	PARAOLIO
13	REC25-70937	911686	ARO TÓRICO	O-RING	ANELLO
14	REC983877	983877	COJINETE	BEARING	CUSCINETTO
15	REC911937	911937	TUERCA PIÑÓN	U-JOINT NUT	DADO
16	REC983878	983878	COJINETE	BEARING	CUSCINETTO
17	REC911698	911698	JUNTA	GASKET	GUARNIZIONE
18	REC911700	911700	ARO TÓRICO	O-RING	ANELLO
19	REC909316	909316	ARO TÓRICO	O-RING	ANELLO
20	REC3853655	3853655	RETÉN	OIL SEAL	PARAOLIO
21	REC802385	911702	JUNTA	GASKET	GUARNIZIONE
22	REC911703	911703	TAPA BOMBA AGUA	WEAR PLATE	COPERCHIO POMPA ACQUA
23	REC777128	777128	TURBINA	IMPELLER	GIRANTE
23	CEF500317	777128	TURBINA OMC	IMPELLER	GIRANTE
24	REC764197	764197	CASQUILLO CUERPO BOMBA	WATER PUMP LINER	BOCCOLA CORPO POMPA
25	REC911704	911704	RETÉN	OIL SEAL	PARAOLIO
26	REC915840	915840	KIT JUNTAS	GASKET SET	KIT GUARNIZIONE
27	REC3852045	303067	ARO TORICO	O-RING	ANELLO
28	REC984744	984744	TAPA BOMBA AGUA	PUMP HOUSING	COPERCHIO POMPA ACQUA
29	REC911697	911697	ARANDELA	WASHER	RONDELLA
30	REC911751	911751	ARANDELA CIERRE	LOCK WASHER	RONDELLA CHIUSURA
31	REC911750	911750	CUERPO COJINETE	BEARING CARRIER	CORPO CUSCINETTO
32	REC911699	911699	BASE BOMBA AGUA	WATER PUMP ADAPTER	BASE POMPA ACQUA
33	REC983967	983967	TAPA	COVER ASSY.	COPERCHIO
34	REC3589522	3852561	TAPA LATERAL	THRUST PLATE	COPERCHIO LATERALE
35	REC3589524	3852562	TAPA LATERAL	THRUST PLATE	COPERCHIO LATERALE
37	RM3852516	910953	ARO RETENEDOR	RETAINER RING	ANELLO FERMO
38	REC911678	911678	GRUESO	SHIM 0.003	SPESSORE
38	REC911679	911679	GRUESO	SHIM 0.004	SPESSORE
38	REC911680	911680	GRUESO	SHIM 0.005	SPESSORE
38	REC911681	911681	GRUESO	SHIM 0.010	SPESSORE
39	REC3852454	908668	TORNILLO	SCREW	VITE
40	REC912614	912614	TUBO	VENT HOSE	TUBO
41	REC912238	912238	TORNILLO	SCREW	VITE
42	REC3852568	3852568	TORNILLO	SCREW	VITE
43	REC123018	123018	TORNILLO	SCREW	VITE
44	REC914488	914488	TORNILLO NIVEL	DIPSTICK	ASTINA
45	REC911662	911662	GRUESO	SHIM 0.003	SPESSORE
45	REC911665	911665	GRUESO	SHIM 0.010	SPESSORE
46	REC911668	911668	GRUESO	SHIM 0.010	SPESSORE



**PARTE INFERIOR  
LOWER GEARCASE  
PARTE INFERIORE  
COBRA (1986-93)**

Las colas Cobra con motores 3.0L de (1986-89) utilizan una parte inferior de menor diámetro como los motores 2.3L de (1987-90). Las posteriores utilizan la misma parte inferior que los V6 y V8.

The (1986-89) Cobra Sterndrives with four-cylinder 3.0L engines utilize a small diameter lower gear housing. The (1990-93) four-cylinder 3.0L Cobra Sterndrives use the same large diameter lower gear housing as the 1986-1993 V6 and V8 powered Cobra Sterndrives. (1987-90) 2.3L engines use the small gear housing.

I piedi Cobra con motori 3.0L del (1986-89) utilizzano la parte bassa differente ed è più piccola come nei motori 2.3L dal (1987-90), utilizzano la stessa parte inferiore che i V6 e V8.

Ref.	R.O. / OEM
REC439967	439967 984458

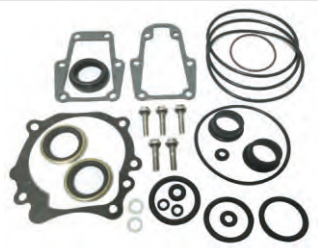

3.0L (1990-93), V6 / V8 (1986-93)  
excepto / except / ecetto KING COBRA

Ref.	R.O. / OEM
REC985612	985612



Kit retenes  
Gasket seal set  
Kit paraoli  
4 Cyl (1986-89), 2.3 L (1987-90)

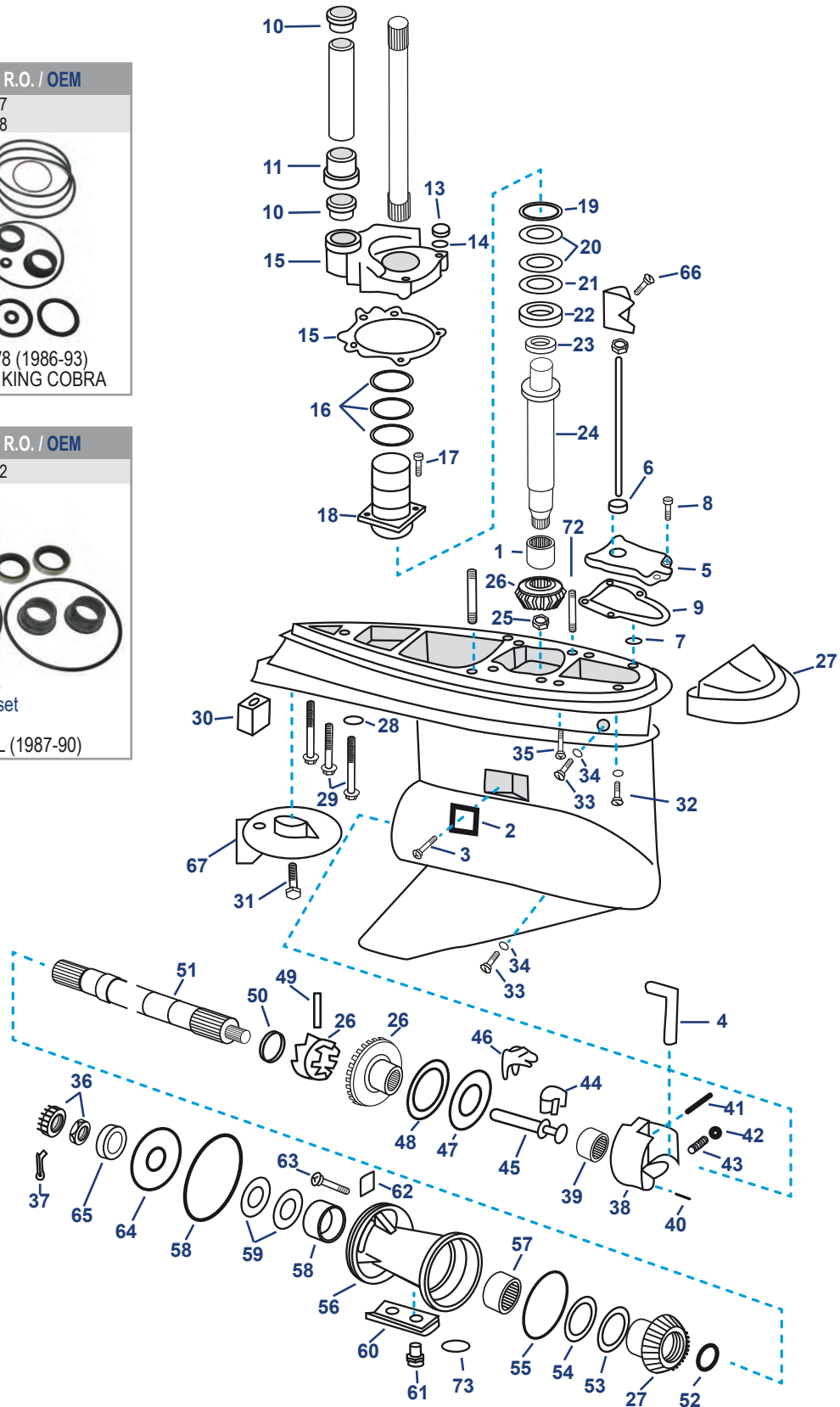

Nº	Ref.	R.O. OEM	Descripción	Description	Descrizione
1	REC387817	387817	COJINETE	PINION BEARING	CUSCINETO
2	REC384195	384195	COJINETE GM 4L	GM 4L BRING	CUSCINETTO GM 4L
2	REC337778	337778	REJILLA	SCREEN	TAPPO
3	REC337061	337061	TORNILLO	SCREW	VITE
4	REC915954	915954	EJE VARILLA CAMBIO	DETENT	ASTICELLA CAMBIO
5	REC986838	986838	TAPA CON RETÉN	COVER & SEAL	TAPPO CON PARAOLIO
6	REC912157	912157	CASQUILLO	WIPER	BOCCOLA
7	REC318372	318372	ARO TÓRICO	O-RING	ANELLO
8	REC304027	304027	TORNILLO	SCREW	VITE
9	REC911878	911878	JUNTA	GASKET	GUARNIZIONE
10	REC911705	911705	RETÉN	SEAL	PARAOLIO
11	REC911715	911715	GUÍA TUBO	GUIDE	GUIDA TUBO
12	REC915720	915720	TAPA GUÍA TUBO	WASHER	COPERCHIO GUIDA TUBO
13	REC11-8267089	121731	TAPÓN	NUT	TAPPO
14	REC12-29245	305981	ARANDELA	WASHER	RONDELLA
15	REC915719	915719	JUNTA	GASKET	GUARNIZIONE
16	REC318717	318717	ARO TÓRICO	O-RING	ANELLO
17	REC317624	317624	TORNILLO	SCREW	VITE
18	REC984462	984462	CUERPO COJINETE	BEARING HNG	CORPO CUSCINETTO
19	REC314728	314728	ARO TÓRICO	O-RING	ANELLO
20	REC323362	323362	SUPLEMENTO .003	SHIM	SPESSORE
20	REC323361	323361	SUPLEMENTO .004	SHIM	SPESSORE
20	REC314745	314745	SUPLEMENTO .005	SHIM	SPESSORE
21	REC327656	327656	ARANDELA TOPE	THRUST WASHER	RONDELLA
22	REC387656	387656	TOPE COJINETE	THRUST BEARING	FERMO CUSCINETTO
23	REC911710	911710	TAPÓN	PLUG	TAPPO
24	REC911693	911693	EJE PRIMARIO	LOWER SHAFT	ASSE PRINCIPALE
25	REC11-35921	314730	TUERCA	NUT	DADO
26	REC5004218	986980	KIT PIÑONES V6-V8 (1986-93)	GEAR SET V6-V8 (1986-93)	KIT PIGNONE V6-V8 (1986-93)
26	REC986979	986979	KIT PIÑONES 4 L (1986-93)	GEAR SET 4L (1986-93)	KIT PIGNONE 4L (1986-93)
27	CM984513	3853818	ANODO	ANODE	ANODO
28	REC330265	330265	ARANDELA	O-RING	RONDELLA
29	REC328096	328096	TORNILLO	SCREW	VITE
30	CM393023	436745	ANODO	ANODE	ANODO
31	REC313715	313715	TORNILLO	SCREW	VITE
32	REC912127	912127	TORNILLO	SCREW	VITE
33	REC22-67892A05	318544	TORNILLO	SCREW	VIRE
34	REC3855081	311598	ARO TÓRICO	O-RING	ANELLO
35	REC331999	331999	TORNILLO	SCREW	VITE
36	REC398042	5008966	KIT TUERCA HÉLICE	NUT & KEEPER	KIT DADO ELICA
37	REC3852056	306394	PASADOR	COTTER PIN	CHIAVISTELLO
38	REC389455	389455	TAPA COJINETE	HOUSING & BEARING ASSY.	COPERCHIO CUSCINETTO
39	REC389039	389039	COJINETE	BEARING	CUSCINETTO
39	REC382407	382407	COJINETE GM 4L	BEARING	CUSCINETTO GM 4L
40	REC331880	331880	PASADOR	PIN	SPINOTTO
41	REC328825	328825	PASADOR	PIN	SPINOTTO
42	REC160084	160084	BOLA	DETENT BALL	BOLLA
43	REC911962	385367	MUELLE	SPRING	MOLLA
44	REC334163	334163	REGULADOR EJE	CRADLE	REGOLATORE ASSE
45	REC322941	322941	EJE DESPLAZABLE	SHAFT	ASSE SELETTORE
46	REC322938	322938	UNA DESPLAZABLE	LEVER	LEVA
47	REC327669	327669	TOPE ARANDELA	THRUST WASHER	RONDELLA
47	REC324766	324766	TOPE ARANDELA GM 4L	THRUST WASHER	RONDELLA GM 4L
48	REC389042	389042	TOPE COJINETE	THRUST BRING	RONDELLA
48	REC385043	385043	TOPE COJINETE GM 4L	GM 4L T B	RONDELLA GM 4L
49	REC313448	313448	PASADOR DESPLAZABLE	CROSS PIN	CHIAVISTELLO
50	REC324369	324369	MUELLE	SPRING	MOLLA
51	REC395209	395209	EJE (1986-90) Ø1-3/16	PROP SHAFT 1-3/16 Ø	ASSE (1986-90) Ø1-3/16
51	REC5004765	5004765	EJE (1991-93) Ø1-1/4	PROP SHAFT 1-1/4 Ø	ASSE (1991-93) Ø1-1/4
51	REC436888	436888	EJE HÉLICE GM 4L	PROP SHAFT GM 4L	ASSE ELICA GM 4L
52	REC336565	336565	ARANDELA	THRUST WASHER	RONDELLA
53	REC382408	382408	TOPE COJINETE	THRUST BEARING	RONDELLA CUSCINETO
54	REC314731	314731	TOPE ARANDELA	THRUST WASHER	RONDELLA
55	REC967344	313446	ARO TÓRICO	O-RING	ANELLO
56	REC5000074	5000074	COJINETE DIÁBOLO 1986-90)	BEARING CARRIER	CUSCINETTO DIAVOLO (1986-90)
56	REC5004257	5004257	COJINETE DIÁBOLO (1991-93)	BEARING CARRIER	CUSCINETTO DIAVOLO (1991-93)
57	REC382407	382407	COJINETE	BEARING	CUSCINETTO
58	REC387247	387247	COJINETE (1986-90)	BEARING	CUSCINETTO
58	REC434467	434467	COJINETE (1991-93)	BEARING	CUSCINETTO
58	REC379504	379504	COJINETE GM 4L	BEARING	CUSCINETTO GM 4L
59	REC334950	334950	RETÉN (1986-90)	OIL SEAL	PARAOLIO
59	REC330137	330137	RETÉN (1991-93)	OIL SEAL	PARAOLIO
60	CM431708	431708	ANODO	ANODE	ANODO
61	REC908158	908158	TORNILLO	SCREW	VITE
62	REC333957	333957	PESTAÑA SUJECCIÓN	TAB	PIASTRA SUPPORTO
63	REC350271	350271	TORNILLO	SCREW	BULLONE
64	REC126870	126870	TOPE ARANDELA	THRUST WASHER	RONDELLA
65	REC320570	320570	TOPE HÉLICE	SPACER	SPESSORE
66	REC308825	308825	TORNILLO	SCREW	VITE
67	TEN00712	912392	ALETA	TRIM TAB	TRIM TAB

**PARTE SUPERIOR  
UPPER GEARCASE  
PARTE SUPERIORE  
COBRA (1994-98)**

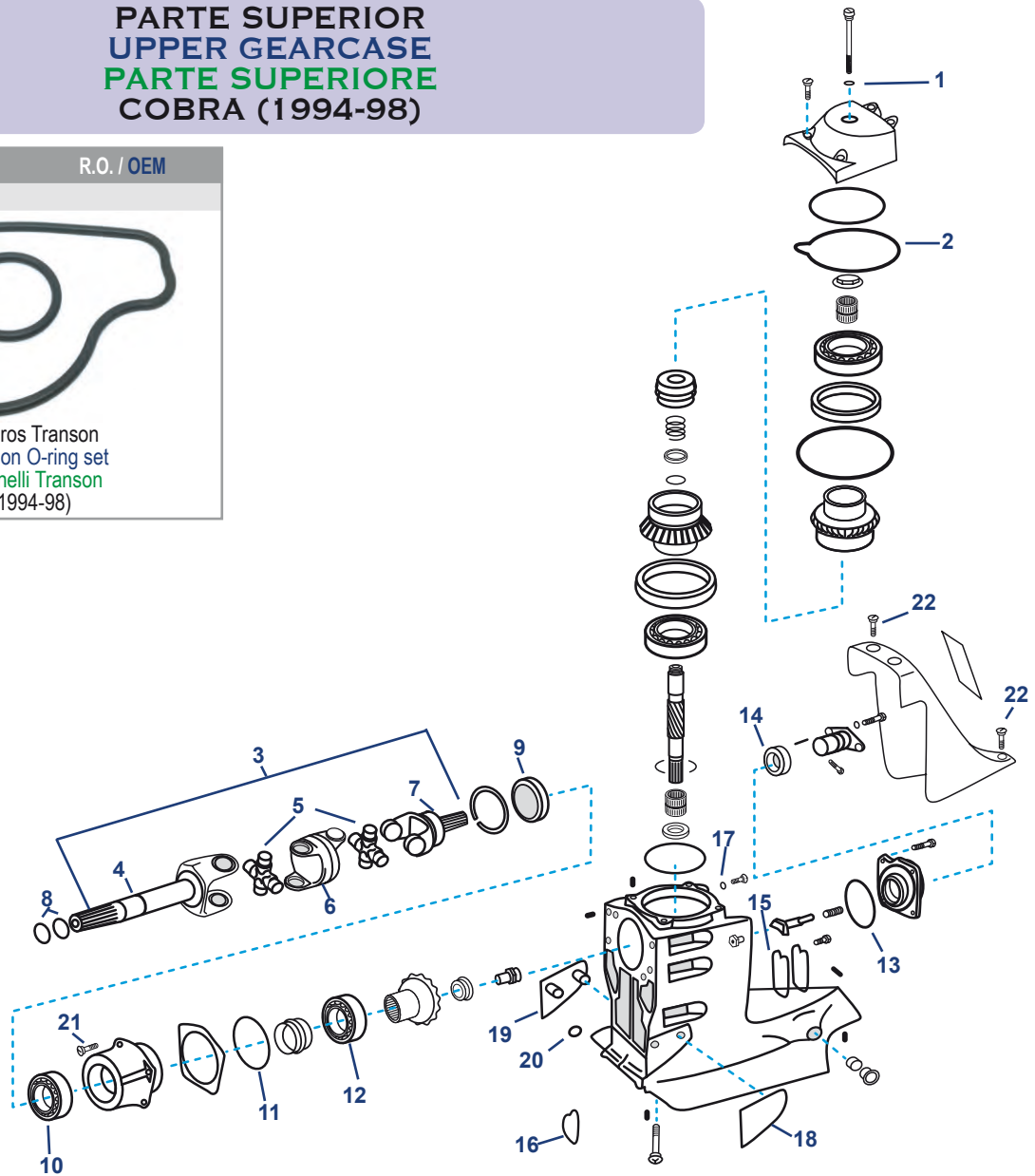
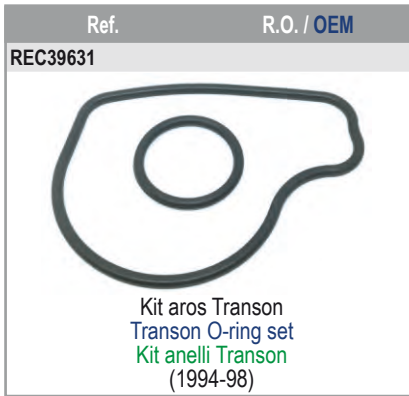

Nº	Ref.	R.O. OEM	Descripción	Description	Descrizione
1	REC3852045	303067	ARANDELA	O-RING	RONDELLA
2	REC3852317	3852317	JUNTA	GASKET	GUARNIZIONE
3	REC3860842	3860842	TRANSMISIÓN	U-JOINT ASSY	TRASMISSIONE
4	REC59830A7	912212	UNION COLA MOTOR	YOKE-LONG	UNION COLA MOTORE
5	REC3850812	3850812	CRUCETA CARDAN	U-JOINT	CROCETTA CARDANO
6	REC393831	912213	CARDAN	SOCKET	CARDANO
7	REC3850814	3850814	EJE CORTO CARDAN	YOKE	ASSE CORTO CARDANO
8	REC25-25439	3852565	ARANDELA	O-RING	RONDELLA
9	REC3852272	3852272	RETEN ACEITE	OIL SEAL	PARAOLIO
10	REC183247	3850853	COJINETE	BEARING	CUSCINETTO
11	REC967344	3852308	ARANDELA	O-RING	RONDELLA
12	REC3850852	3850852	COJINETE	BEARING	CUSCINETTO
13	REC925093	925093	ARANDELA	O-RING	RONDELLA
14	REC853868	853858	RETEN ACEITE	OIL SEAL	PARAOLIO
15	REC3852279	3852279	JUNTA	GASKET	GUARNIZIONE
16	REC3852560	3852560	RETEN	SEAL	TENUTA
17	REC3855081	333572	JUNTA	GASKET	GUARNIZIONE
18	REC3589522	3852561	TAPA	THRUST PLATE	COPERCHIO
19	REC3589524	3852562	TAPA	THRUST PLATE	COPERCHIO
20	REC3852165	910953	ARO RETENEDOR	RETAINING RING	TENUTA
21	REC3852454	908668	TORNILLO	SCREW	VITE
22	REC3852568	3852568	TORNILLO	SCREW	VITE

**PARTE INFERIOR**  
**LOWER GEARCASE**  
**PARTE INFERIORE**  
**COBRA (1994-98)**

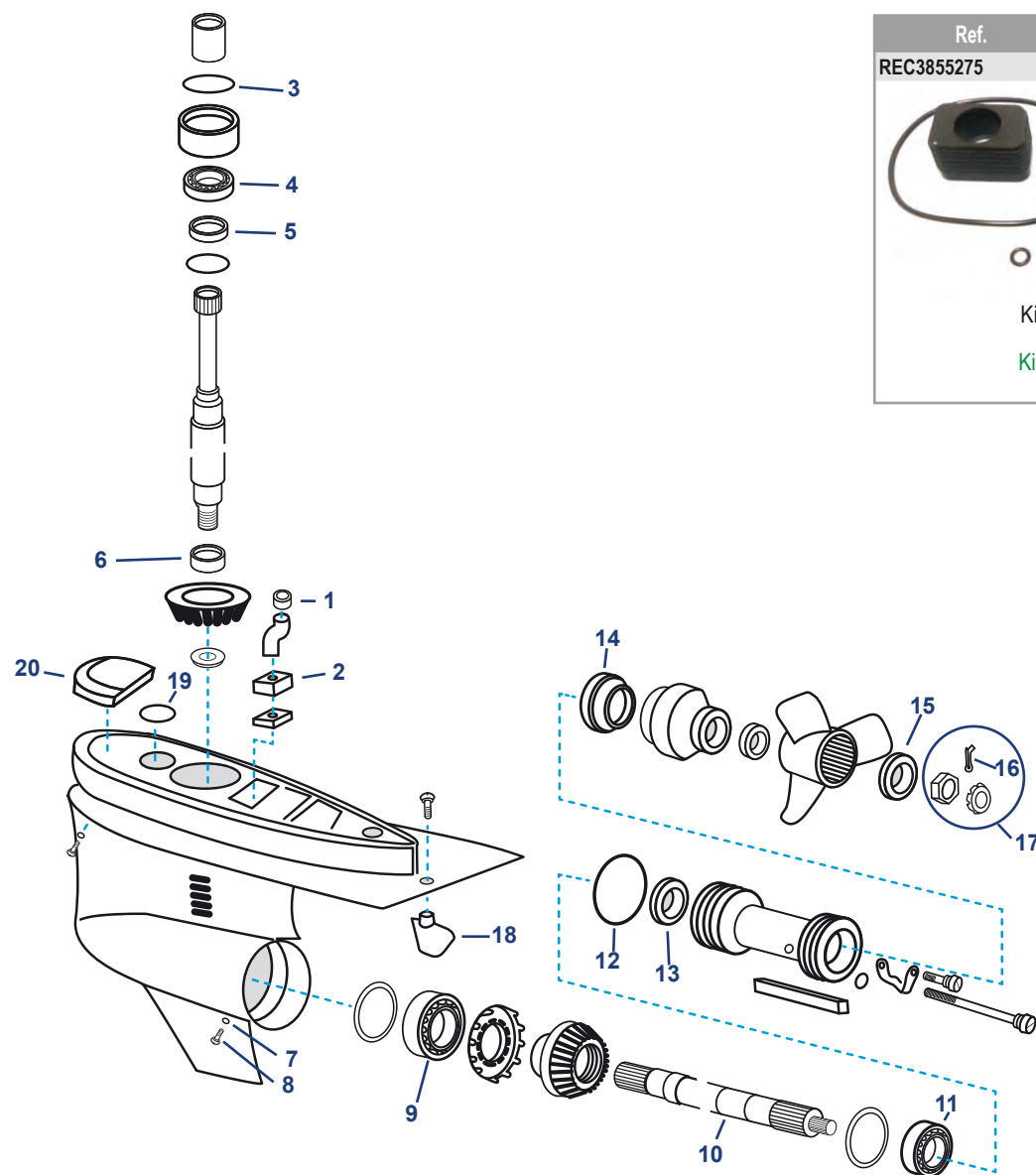

Nº	Ref.	R.O. OEM	Descripción	Description	Descrizione
1	REC3852315	3852315	SUPLEMENTO	GROMMET	SPESSORE
2	REC3854595	3854595	RETÉN	SEAL	TENUTA
3	REC3852866	3852866	ARO	O-RING	ANELLO
4	REC31-86748A1	3854250	COJINETE	BEARING	CUSCINETTO
5	REC31-66668A1	3854249	COJINETE	BEARING	CUSCINETTO
6	REC3853934	3853934	COJINETE	BEARING	CUSCINETTO
7	REC3855081	333572	ARANDELA	WASHER	RONDELLA
8	REC22-67892A05	3854539	TORNILLO	SCREW	VITE
9	REC3850942	3850942	COJINETE	BEARING	CUSCINETTO
10	REC3857675	3857675	EJE HÉLICE	PROP SHAFT	ASSE ELICA
11	REC31-66668A1	3854249	COJINETE	BEARING	CUSCINETTO
12	REC3852865	3852865	ARO	O-RING	ANELLO
13	REC3863090	3863090	RETÉN ACEITE	OIL SEAL	PARAOILIO
14	REC126870	126870	CIERRE HÉLICE	THRUST WASHER	CHIUSURA ELICA
15	REC3852350	3852350	ESPACIADOR	SPACER	DISTANZIALE
16	REC3852056	306394	PASADOR	COTTER PIN	CHIAVISTELLO
17	REC398042	5008966	KIT TUERCA HÉLICE	NUT & KEEPER	KIT DADO
18	REC854040	3854402	TIMON COLA	TRIM TAB	TIMONE PIEDE
19	REC3852959	3852959	ARO	O-RING	ANELLO
20	CM3855411	3855411	ANODO	ANODE	ANODO

PARTE SUPERIOR COLA  
UPPER GEAR HOUSING-STRINGER MOUNT  
PARTE SUPERIORE PIEDE  
400-800 (1973-85)

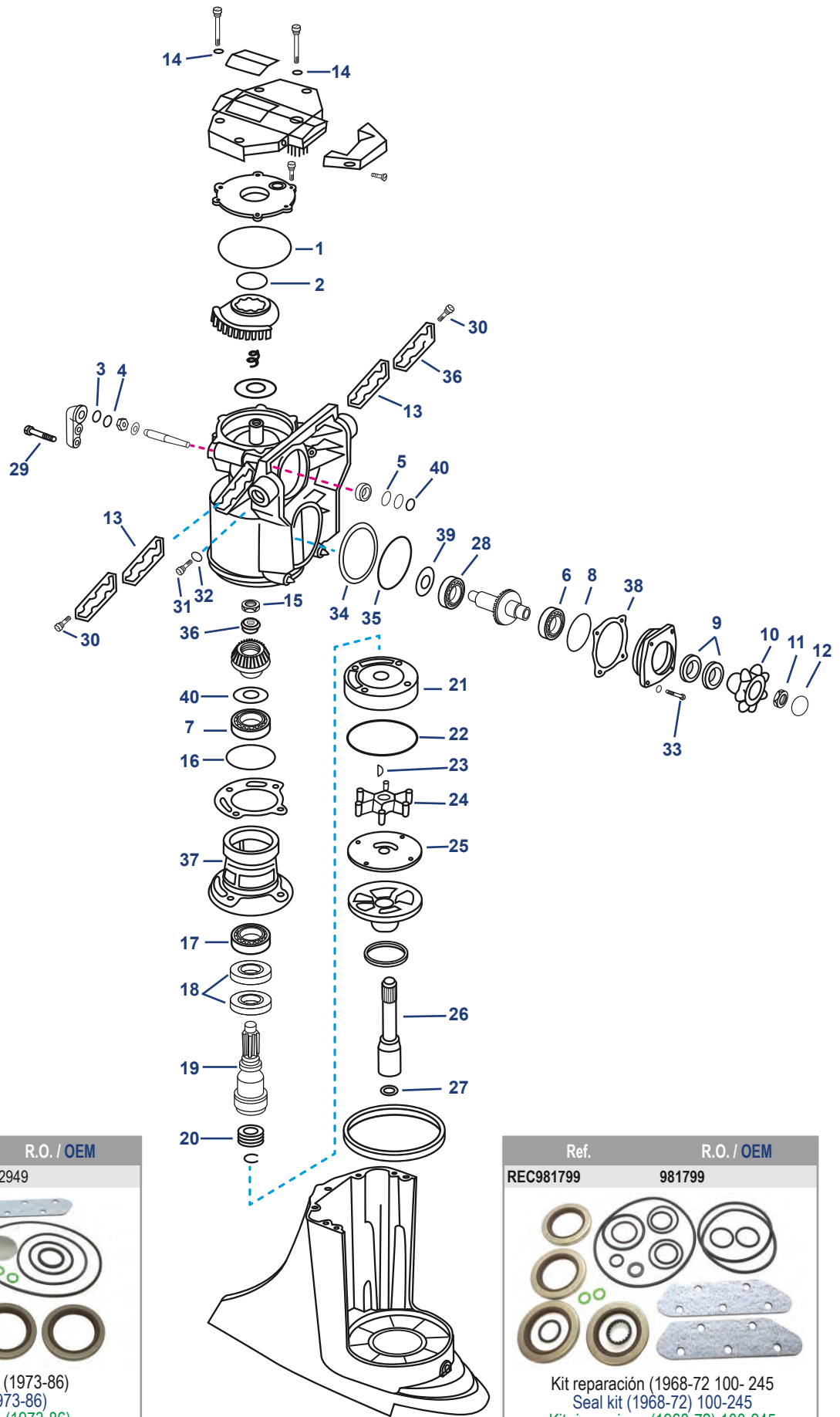

Ref.	R.O. / OEM
REC982949	982949
Kit reparación (1973-86) Seal kit (1973-86) Kit riparazione (1973-86)	

Ref.	R.O. / OEM
REC981799	981799
Kit reparación (1968-72) 100-245 Seal kit (1968-72) 100-245 Kit riparazione (1968-72) 100-245	

Nº	Ref.	R.O. OEM	Descripción	Description	Descrizione
1	REC313175	313175	ANILLO GOMA	O-RING	ANELLO IN GOMMA
2	REC25-30224	310327	ANILLO GOMA (C.ELÉCTRICO)	O-RING (ELEC. SHIFT)	ANELLO IN GOMMA (CAVI ELETTRICO)
2	REC25-30224	910582	ANILLO GOMA (400-800)	O-RING	ANELLO IN GOMMA (400-800)
3	REC125017	302540	ANILLO GOMA (ANTIGUO)	O-RING (EARLY MODEL)	ANELLO IN GOMMA (VECCHIO)
3	REC909140	909140	ANILLO GOMA (MODERNO)	O-RING (LATE MODEL)	ANELLO IN GOMMA (MODERNO)
4	REC909139	909139	RETÉN	QUAD RING	PARAOLIO
5	REC909048	909048	RETÉN	QUAD RING	PARAOLIO
6	REC382212	382212	COJINETES	BEARING	CUSCINETTO
7	REC379585	379585	COJINETES	BEARING	CUSCINETTO
8	REC25-35029	308621	ANILLO RETÉN	O-RING	ANELLO
9	REC981196	981196	RETÉN	OIL SEAL	PARAOLIO
10	REC908069	908069	ENGRANAJE	BALL GEAR	INGRANAGGIO
11	REC908064	908064	TUERCA	NUT	DADO
12	REC908062	908062	TAPA	COVER	COPERCHIO
13	REC308592	308592	JUNTA	GASKET	GUARNIZIONE
14	REC315189	315189	JUNTA	GASKET	GUARNIZIONE
15	REC907866	907866	CONTRATUERCA	LOCK NUT	CONTRO DADO
16	REC553126	553126	ANILLO GOMA	O-RING	ANELLO IN GOMMA
17	REC382165	382165	COJINETE	BEARING	CUSCINETTO
18	REC981268	981268	RETÉN	OIL SEAL	PARAOLIO
19	REC909121	909121	EJE TRANSMISIÓN	DRIVE SHAFT	ASSE TRASMISSIONE
19	REC981220	981220	EJE TRANSMISIÓN	DRIVE SHAFT	ASSE TRASMISSIONE
19	REC382883	382883	EJE TRANSMISIÓN	DRIVE SHAFT	ASSE TRASMISSIONE
20	REC907774	907774	RETÉN EJE	SHAFT SEAL	TENUTA ASSE
21	REC983298	983298	CUERPO BOMBA AGUA	PUMP HOUSING	CORPO POMPA ACQUA
22	REC910238	910238	ANILLO GOMA	O-RING	ANELLO
23	REC308928	308924	CHAVETA	KEY	CHIAVETTA
24	REC777130	777130	IMPULSOR	IMPELLER	GIRANTE
25	REC313176	313176	TAPA BOMBA AGUA	PUMP PLATE	COPERCHIO POMPA ACQUA
26	REC909753	909753	EJE CORTO BOMBA	SHORT DRIVE SHAFT	ASSE CORTO POMPA
26	REC908087	908087	EJE LARGO BOMBA	LONG DRIVE SHAFT	ASSE LUNGO POMPA
27	REC314491	314491	ANILLO GOMA	O-RING	ANELLO
28	REC375761	375761	COJINETE	BEARING	CUSCINETTO
29	REC305282	305282	TORNILLO	SCREW	VITE
30	REC328694	3852473	TORNILLO	SCREW	VITE
31	REC22-67892A05	318544	JUEGO TORNILLOS	SCREW SET	KIT VITI
32	REC3855081	311598	JUNTA	GASKET	GUARNIZIONE
33	REC909386	909386	TORNILLO	SCREW	VITE
34	REC308768	308768	RETÉN	SEAL	TENUTA
35	REC308590	308590	MUELLE	SPRING	MOLLA
36	REC909123	909123	TOPE PIÑÓN	CENTERING CONE	FERMO PIGNONE
37	REC910240	910240	TAPA	BEARING HOUSING	COPERCHIO
38	REC313202	313202	SUPLEMENTO A .002	SHIM	SPESSORE .002
38	REC313203	313203	SUPLEMENTO A .003	SHIM	SPESSORE .003
38	REC313204	313204	SUPLEMENTO A .004	SHIM	SPESSORE .004
38	REC313205	313205	SUPLEMENTO A .005	SHIM	SPESSORE .005
38	REC313206	313206	SUPLEMENTO A .006	SHIM	SPESSORE .006
39	REC313163	313163	SUPLEMENTO A .003	SHIM	SPESSORE .003
39	REC313164	313164	SUPLEMENTO A .004	SHIM	SPESSORE .004
39	REC313167	313167	SUPLEMENTO A .007	SHIM	SPESSORE .007
40	REC313194	313193	SUPLEMENTO A .003	SHIM	SPESSORE .003
40	REC313194	313194	SUPLEMENTO A .004	SHIM	SPESSORE .004
40	REC313195	313195	SUPLEMENTO A .005	SHIM	SPESSORE .005
40	REC313196	313196	SUPLEMENTO A .006	SHIM	SPESSORE .006
40	REC313197	313197	SUPLEMENTO A .007	SHIM	SPESSORE .007
40	REC313198	313198	SUPLEMENTO A .008	SHIM	SPESSORE .008
40	REC313199	313199	SUPLEMENTO A .009	SHIM	SPESSORE .009
40	REC313200	313200	SUPLEMENTO A .010	SHIM	SPESSORE .010

PARTE INFERIOR COLA  
LOWER GEAR HOUSING-STRINGER MOUNT  
PARTE INFERIORE PIEDE  
400-800 (1973-85)

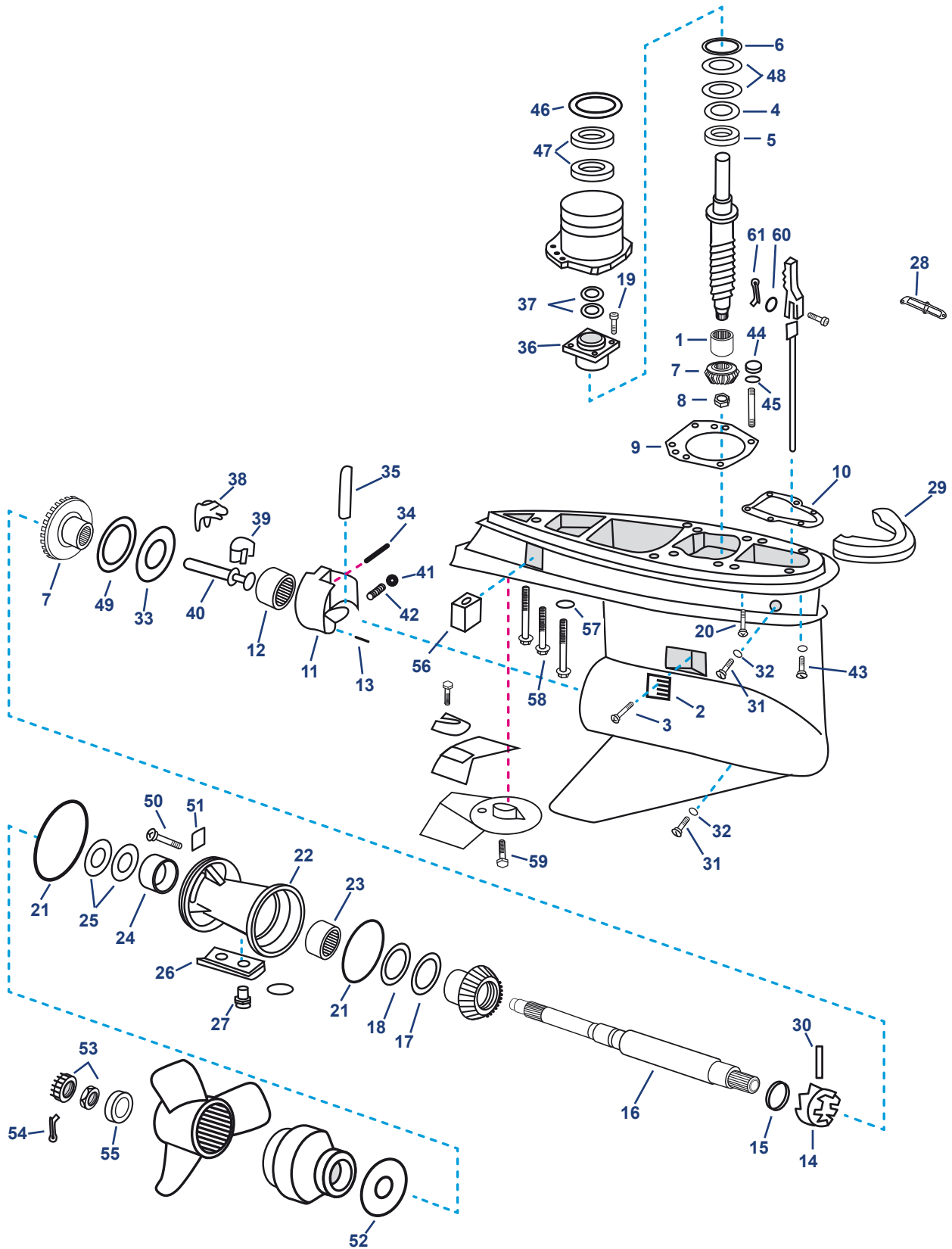

Nº	Ref.	R.O. OEM	Descripción	Description	Descrizione
1	REC387817	387817	COJINETE	PINION BEARING	CUSCINETTO
1	REC384195	384195	COJINETE GM 4CIL	PINION BEARING	CUSCINETTO GM 4 CIL
2	REC337778	337778	REJILLA	SCREEN	RETINA
3	REC337061	337061	TORNILLO	SCREW	BULLONE
4	REC327656	327656	TOPE ARANDELA	THRUST WASHER	FERMO RONDELLA
5	REC387656	387656	TOPE COJINETE	THRUST BEARING	FERMO CUSCINETTO
6	REC314728	314728	ANILLO GOMA	O-RING	ANELLO
7	REC320635	5004941	KIT COMPLETO PIÑONES 5.0,5.8-V8	P/FORWARD GEAR SET 5.0, 5.8-V8	KIT PIGNONI COMPLETO 5.0, 5.8 - V8
8	REC11-35921	314730	TUERCA	NUT	DADO
9	REC910236	910236	JUNTA	GASKET	GUARNIZIONE
9	REC338484	910338	JUNTA GM 4 CIL.	GASKET	GUARNIZIONE GM 4 CYL
10	REC324670	352165	JUNTA	GASKET	GUARNIZIONE
11	REC389455	389455	TAPA COJINETE	HSNG & BRING ASSY.	COPERCHIO CUSCINETTO
12	REC389039	389039	COJINETE	BEARING	CUSCINETTO
12	REC382407	382407	COJINETE 4 CIL	BEARING	CUSCINETTO
13	REC331880	331880	PASADOR	PIN	CHIAVISTELLO
14	REC337774	337774	DESPLAZABLE	CLUTCH DOG	SCORREVOLE
14	REC323664	323664	DESPLAZABLE	CLUTCH DOG	SCORREVOLE
15	REC324369	324369	MUELLE	SPRING	MOLLA
16	REC395209	395209	EJE HÉLICE 800 MOD.	PROP SHAFT	ASSE ELICA 800
16	REC436888	436888	EJE HÉLICE 1976-86	PROP SHAFT	ASSE ELICA 1976-86
17	REC382408	382408	TOPE COJINETE	THRUST BEARING	FERMO CUSCINETTO
18	REC314731	314731	TOPE ARANDELA	THRUST WASHER	FERMO RONDELLA
19	REC317624	317624	TORNILLO	SCREW	VITE
20	REC331999	331999	TORNILLO 3/8X1 3/4-16	SCREW 3/8 X 1 3/4-16	VITE 3/8 X 1 3/4-16
21	REC305123	305123	ARO	O-RING	ANELLO
21	REC313446	313446	ARO 4 CIL	O-RING	ANELLO 4 CYL
22	REC5000074	5000074	COJINETE DIÁBOLO	BEARING CARRIER	CUSCINETTO DIAVOLO
23	REC382407	382407	COJINETE	BEARING	CUSCINETTO
24	REC387247	387247	COJINETE	BEARING	CUSCINETTO
24	REC379504	379504	COJINETE 4 CIL	BEARING	CUSCINETTO 4 CIL
25	REC26-76868	320862	RETÉN	OIL SEAL	PARAOLIO
25	REC330137	330137	RETÉN 4 CIL	OIL SEAL	PARAOLIO 4 CIL
26	CM431708	431708	ANODO	ANODE	ANODO
27	REC908158	908158	TORNILLO	SCREW	VITE
28	REC909604	909604	JUNTA	GASKET	GUARNIZIONE
29	CM983494	983494	ANODO	ANODE	ANODO
30	REC313448	313448	PASADOR DESPLAZABLE	CROSS PIN	CHIAVISTELLO SCORREVOLE
31	REC22-67892A05	318544	TORNILLO CON RETÉN	DRAINIG SCREW	BULLONE CON ANELLO
32	REC3855081	311598	JUNTA	GASKET	GUARNIZIONE
33	REC327669	327669	TOPE ARANDELA	THRUST WASHER	FERMO RONDELLA
33	REC324766	324766	TOPE ARANDELA 4 CIL	THRUST WASHER	FERMO RONDELLA 4 CIL
34	REC328825	328825	PASADOR	PIN	CHIAVISTELLO
34	REC313448	320145	PASADOR 4 CIL	PIN	CHIAVISTELLO 4 CIL
35	REC910310	910310	PASADOR	PIN	CHIAVISTELLO
36	REC982422	982422	TAPA RETENES	BEARING & HG SEAL	COPERCHIO PARAOLIO
37	REC321467	321467	RETÉN	OIL SEAL	PARAOLIO
38	REC322938	322938	UÑA DESPLAZABLE	LEVER	CHIAVETTA
39	REC334163	982422	REGULADOR EJE	CRADLE	CHIAVETTA 4 CIL
40	REC322941	322941	EJE	SHAFT	ASSE
41	REC160084	160084	BOLA	DETENT BALL	BOLLA
42	REC911962	911962	MUELLE	SPRING	MOLLA
43	REC912127	912127	TORNILLO	SCREW	VITE
44	REC11-8267089	121731	TUERCA	NUT	DADO
45	REC12-29245	305981	ARANDELA	O-RING	RONDELLA
46	REC310649	310649	RETÉN	OIL SEAL	PARAOLI
47	REC313353	313353	RETÉN	OIL SEAL	PARAOLI
48	REC314745	314745	SUPLEMENTO.005	SHIM	SPESSORE .005
48	REC323361	323361	SUPLEMENTO.004	SHIM	SPESSORE .004
48	REC323362	323362	SUPLEMENTO.003	SHIM	SPESSORE .003
49	REC389042	389042	TOPE COJINETE	THRUST BEARING	FERMO CUSCINETTO
49	REC385043	385043	TOPE COJINETE 4 CIL	THRUST BEARING	FERMO CUSCINETTO 4 CIL
50	REC350271	350271	TORNILLO	SCREW	VITE
51	REC333957	333957	PESTAÑA SUJECCIÓN	TAB	TAB
52	REC126870	126870	TOPE ARANDELA (800)	THRUST WASHER	FERMO CUSCINETTO 800
52	REC127084	127084	TOPE ARANDELA 4 CIL	THRUST WASHER	FERMO CUSCINETTO 4 CIL
53	REC314503	5008966	TUERCA 4 CIL	NUT	DADO 4 CIL
53	REC398042	398042	TUERCA (800)	NUT	DADO 800
54	REC314502	314502	PASADOR 4 CIL	PIN	CHIAVISTELLO 4 CIL
54	REC3852056	306394	PASADOR (800)	PIN	CHIAVISTELLO 800
55	REC320570	320570	TOPE HÉLICE (800)	SPACER	FERMO ELICA 800
55	REC315810	315810	TOPE HÉLICE (400)	SPACER	FERMO ELICA 400
56	CM393023	436745	ANODO	ANODE	ANODO
57	REC330265	330265	ARANDELA	LOCK WASHER	RONDELLA
58	REC328096	328096	TORNILLO	SCREW	VITE
59	REC313715	313715	TORNILLO	SCREW	VITE
60	REC328702	306358	ARANDELA	WASHER	RONDELLA
61	REC306376	306376	PASADOR	COTTER PIN	CHIAVISTELLO



**TRANSOM  
TRANSOM SHIELD  
TRANSOM  
COBRA (1986-93)**

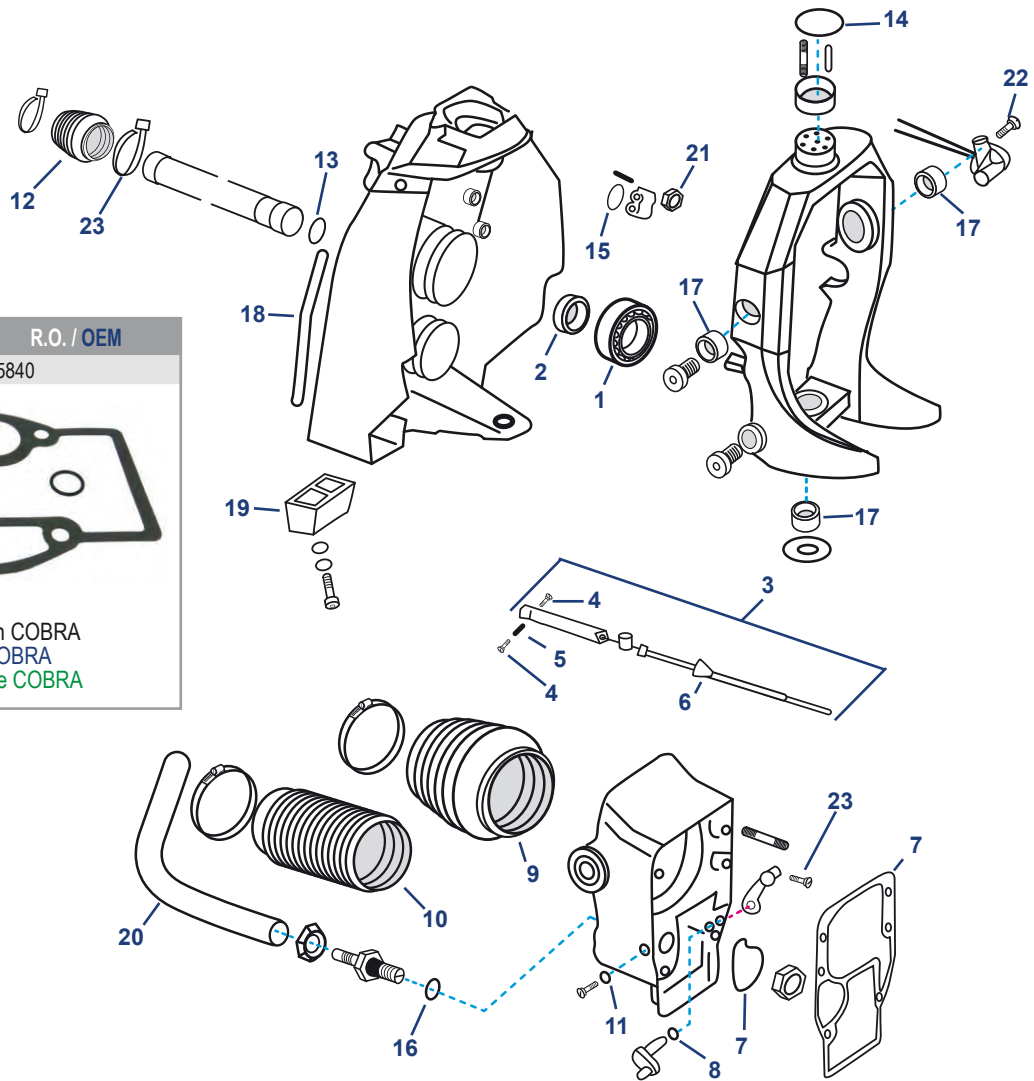
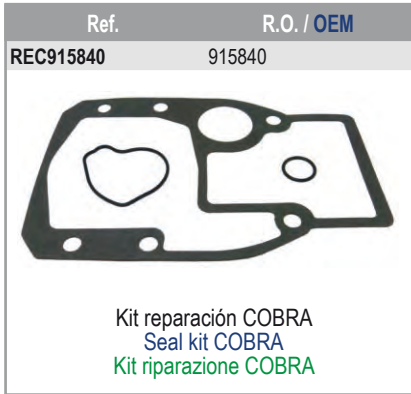

Nº	Ref.	R.O. OEM	Descripción	Description	Descrizione
1	REC30-879194A01	3853807	COJINETE TRANSOM	GIMBAL BEARING	CUSCINETTO TRANSOM
2	REC3852548	3852548	RETÉN TRASERO	REAR SEAL	PARAOILIO POSTERIORE
3	REC987661	987661	CABLE CAMBIO COBRA	SHIFT CABLE ASSEMBLY	CAVO CAMBIO COBRA
3	REC987678	987678	CABLE CAMBIO KING COBRA	SHIFT CABLE ASSEMBLY (KING COBRA)	CAVO CAMBIO KING COBRA
4	REC10-20518	912304	TORNILLO	SET SCREW	VITE
5	REC43436	915918	ANCLAJE	ANCHOR	FERMO
6	REC304174	304174	ARO TORICO	O-RING	ANELLO
7	REC915840	915840	KIT DE JUNTAS	GASKET SET	KIT GUARNIZIONE
8	REC25-48171	202893	ARO TORICO	O-RING	ANELLO
9	REC3841481	3854127	FUELLE TRANSOM	U-JOINT BELLOW	CUFFIA TRANSOM
9	CEF500514K	3854127	FUELLE TRANSOM	U-JOINT BELLOW	CUFFIA TRANSOM
10	REC914036	914036	FUELLE ESCAPE	EXHAUST BELLOW	CUFFIA SCARICO
10	CEF500527K	914036	FUELLE ESCAPE	EXHAUST BELLOW	CUFFIA SCARICO
11	REC332583	911311	ARO	O-RING	ANELLO
12	CEF500506	911826	FUELLE CABLE CAMBIO	SHIFT CABLE BELLOW	CUFFIA CAVO CAMBIO
13	REC309731	911871	ARO	O-RING	ANELLO
14	REC25-33145	302337	ARO	O-RING	ANELLO
15	REC331188	322501	ARO	O-RING	ANELLO
16	REC3852535	911718	ARO	O-RING	ANELLO
17	REC3808228	3852544	CASQUILLO	PIVOT PIN BEARING	BOCCOLA
18	REC3852550	3852550	JUNTA TRANSOM	GASKET	GUARNIZIONE
19	TEN00919	3853930	ANODO	ANODE	ANODO
20	REC3852352	911830	TUBO SUBIDA AGUA	TRIM HOSE UP	TUBO ACQUA
21	REC11-8267089	121731	TUERCA	LOCK NUT	DADO
22	REC308825	308825	TORNILLO	SCREW	VITE
23	REC908158	908158	TORNILLO	SCREW	VITE

# TRANSON ANTIGUO INTERMEDIATE HOUSING-STRINGER MOUNT TRANSONVECCHIO

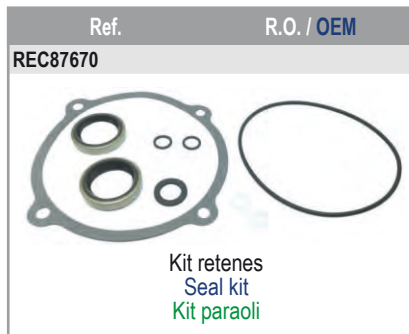
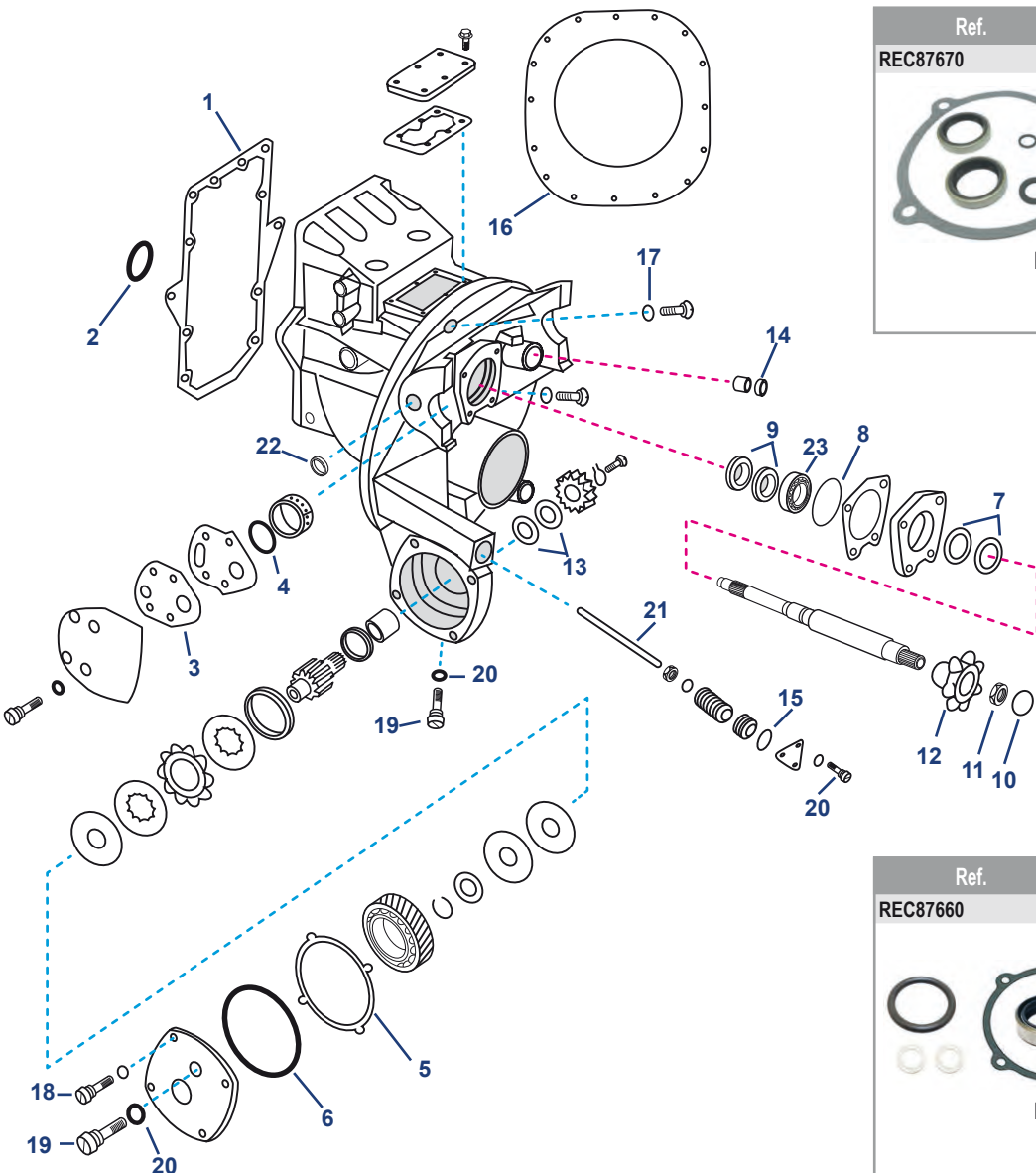

Nº	Ref.	R.O. / OEM	Descripción	Description	Descrizione
2	REC909515	909515	JUNTA	GASKET	GUARNIZIONE
2	REC25-33145	302337	ARO GOMA	O-RING	ANELLO
3	REC323338	316499	JUNTA CAMBIO ELECTRONICO	ELEC. SHIFT GASKET	GUARNIZIONE CAMBIO ELETTRONICO
4	REC25-457101	308626	ARO GOMA	O-RING	ANELLO
5	REC308799	308799	JUNTA	GASKET	GUARNIZIONE
6	REC908194	908194	ARO GOMA	O-RING	ANELLO
7	REC981195	981195	RETÉN	OIL SEAL	PARAOLIO
8	REC908383	908383	ARO	O-RING	ANELLO
9	REC26-419533	764337	RETÉN	OIL SEAL	PARAOLIO
10	REC908062	908062	TAPA	COVER	COPERCHIO
11	REC908064	908064	TUERCA	NUT	DADO
12	REC908063	908063	ENGRANAJE	BALL GEAR	INGRANAGGIO
13	REC321467	321467	RETÉN	OIL SEAL	PARAOLIO
14	REC908855	908855	RETÉN	OIL SEAL	PARAOLIO
15	REC125017	302540	ARO	O-RING	ANELLO
16	REC313080	313080	GOMA TRANSON 120HP (1967-77)	PLATE SEAL 120 HP (1967-77)	GOMMA TRANSON 120 HP (1967-77)
16	REC909527	909527	GOMA TRANSON (1978-86)	PLATE SEAL (1978-86)	GOMMA TRANSON (1978-86)
17	REC315189	315189	JUNTA	GASKET	GUARNIZIONE
18	REC909386	909386	TORNILLO	SCREW	VITE
19	REC10-79953Q04	307551	TORNILLO	SCREW	VITE
20	REC3855081	311598	JUNTA	GASKET	GUARNIZIONE
21	REC980183	980183	EJE ELEVADOR	TILT SHAFT	ALBERINO
22	REC313244	313244	JUNTA	GASKET	GUARNIZIONE
23	REC31-86748A1	3854250	COJINETE	BEARING	CUSCINETTO

**KITS REPARACIÓN  
REPAIR KITS  
KITS RIPARAZIONE**

Ref.	R.O. OEM
REC915840	915840

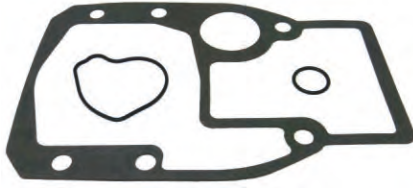

Ref.	R.O. OEM
REC981801	981801

**MOTORES / ENGINES / MOTORI**  
100 - 245 (1968-72)

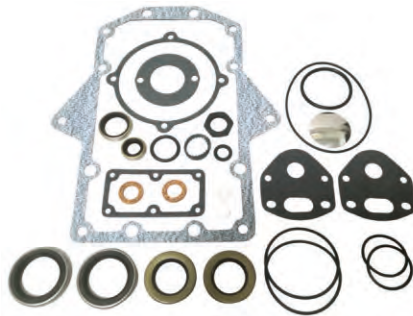

**KIT RETENES TRANSOM  
TRANSOM SEAL KITS  
KIT PARAOLIO TRANSOM**

Ref.	R.O. OEM
REC87660	



REF	R.O./OEM			
REC125017	302540	ARO	O-RING	ANELLO
REC308799	308799	JUNTA	GASKET	GUARNIZIONE
REC12-191833	311598	ARANDELA	WASHER	RONDELLA
REC908194	908194	ARO	O-RING	ANELLO
REC911019	911019	RETÉN	OIL SEAL	PARAOLIO

Ref.	R.O. OEM
REC87670	

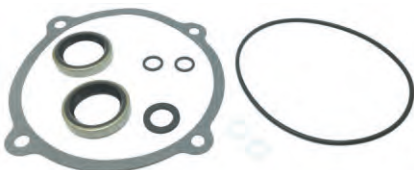

REF	R.O./OEM			
REC125017	302540	ARO	O-RING	ANELLO
REC308799	308799	JUNTA	GASKET	GUARNIZIONE
REC3855081	311598	ARANDELA	WASHER	RONDELLA
REC908194	908194	ARO	O-RING	ANELLO
REC321467	321467	RETÉN	OIL SEAL	PARAOLIO

**KIT RETENES PARTE INFERIOR  
GEARCASE SEAL KITS  
KIT PARAOLIO PARTE BASSA  
400-800**

Ref.	R.O. OEM
REC981797	981797

**MOTORES / ENGINES / MOTORI**  
100 - 245  
(1968-77)  
Cambio eléctrico / electric shift /  
cambio elettrico

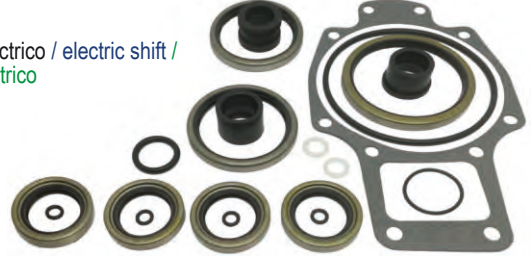

Ref.	R.O. OEM
REC982946	982946

**MOTORES / ENGINES / MOTORI**  
V6-V8  
(1978-86)  
Cambio mecánico / mechanic shift / cambio meccanico

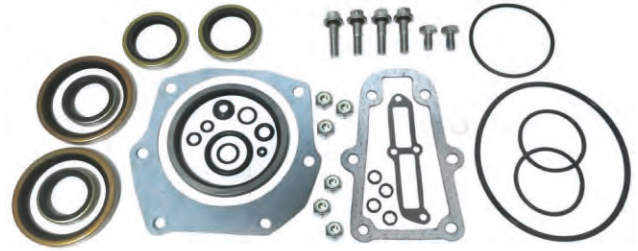

Ref.	R.O. OEM
REC982947	982947

**MOTORES / ENGINES / MOTORI**  
4 Cil.  
(1978-86)  
Cambio mecánico / mechanic shift / cambio meccanico

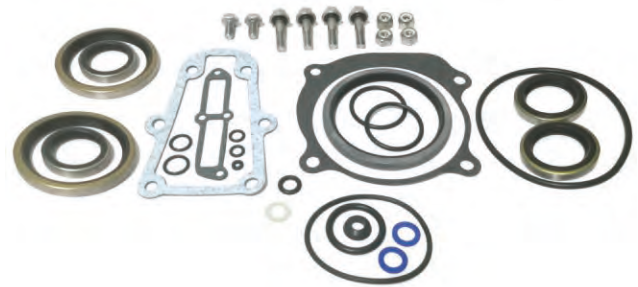

**GOMA TRANSOM  
PLATE SEAL  
GOMMA TRANSOM**

Ref.	R.O. OEM
REC313080	313080

**MOTORES / ENGINES / MOTORI**  
(1967-77) 120 HP+

Ref.	R.O. OEM
REC909527	909527

**MOTORES / ENGINES / MOTORI**  
(1978-86)



**EJES BOMBA AGUA  
WATER PUMP SHAFTS  
ASSE POMPA ACQUA**

**EJE CORTO  
SHORT SHAFT  
ASSE CORTO**



Ref.	R.O. OEM
REC909753	909753

**EJE LARGO  
LONG SHAFT  
ASSE LUNGO**



Ref.	R.O. OEM
REC908087	908087

**KIT BOMBA AGUA  
WATER PUMP KIT  
KIT POMPA ACQUA**

Ref.	R.O. OEM
REC879031	983218

**MOTORES / ENGINES / MOTORI**  
100 - 260 (1962-85)  
Excepto / Except / *eccetto* COBRA



REF	R.O./OEM			
REC310584	310584	ARO	O-RING	ANELLO
REC25-30613	310585	ARO	O-RING	ANELLO
REC313176	313178	TAPA BOMBA	PUMP PLATE	COPERCHIO POMPA
REC314491	314491	ARO	O-RING	ANELLO
REC777130	379475	TURBINA	IMPELLER	GIRANTE
REC907774	907774	RETÉN	OIL SEAL	PARAOILIO
REC910238	910238	ARO	O-RING	ANELLO
REC983298	983298	CARCASA	PUMP HOUSING	CARCASSA POMPA

**JUNTAS  
GASKETS  
GUARNIZIONI**

**VARILLA ACEITE  
DIPSTICK  
ASTICELLA DELL'OLIO**

Ref.	R.O. OEM
REC315189	315189



**SALIDA AGUA  
WATER OUTLET  
PASSAGGIO DELL'ACQUA**

Ref.	R.O. OEM
REC27-8146801	311069 3789161GM



**CIERRE COBRA  
OUTDRIVE SEAL COBRA  
CHIUSURA COBRA**

Ref.	R.O. OEM
REC3852560	3852560



**CAMBIO ELECTRÓNICO  
SWIVEL BRG. ELECT. SHIFT  
CAMBIO ELETTRONICO**

Ref.	R.O. OEM
REC313386	313368

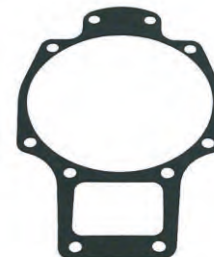

**CAMBIO MECÁNICO  
SWIVEL BRG. MECH SHIFT  
CAMBIO MECCANICO**

Ref.	R.O. OEM
REC338484	910338 324701 338484



**RETENES  
SEALS  
PARAOILIO**

**GUÍA AROS TÓRICOS  
O-RING GUIDE  
GUIDA TENUTE**

Ref.	R.O. OEM	Ø int	Ø ext	Grueso Thick Spessore
REC25-48171	202893	3/8	1/2	1/16
REC301877	301877	31/128	73/128	21/128
REC301967	301967	13/16	1	3/32
REC25-33145	302337	2	2 1/4	1/8
REC302537	302537	1 3/8	1 9/16	3/32
REC125017	302540	1	1 1/4	1/8
REC302588	302588	1 3/4	2	1/8
REC3852045	303067	3/8	9/16	3/32
REC25-62702	303191	5/16	7/16	1/16
REC303347	303347	7/16	5/8	3/32
REC25-35027	303360	1 1/16	1 5/16	1/8
REC304174	304174	1/2	5/8	1/16
REC305123	305123	3 3/4	4	1/8
REC305242	305242	5/16	9/16	1/8
REC3852928	305270	1 5/8	1 7/8	1/8
REC332583	305739	1/4	3/8	1/16
REC25-80863	307082	2 5/8	2 7/8	1/8
REC307450	307450	7/16	9/16	1/16
REC25-38933	307853	7/32	11/32	1/16
REC25-35029	308621	3 1/8	3 3/8	1/8
REC25-29845	308624	15/16	1 1/8	3/32
REC25-457101	308626	1 7/16	1 5/8	3/32
REC308627	308627	2 1/4	2 1/2	1/8
REC308876	308876	2 1/4	2 7/16	3/32
REC309731	309731	1 3/16	1 3/8	3/32
REC25-30224	310327	1 7/8	2 1/8	1/8
REC310414	310414	3 5/8	3 7/8	1/8
REC310584	310584	3/4	1	1/8
REC25-30613	310585	3/4	15/16	3/32
REC25-30613	310967	3/4	15/16	3/32
REC25-62705	311338	3/4	7/8	1/16
REC313175	313175	4 3/4	5	1/8
REC313340	31340	1 11/16	1 7/8	3/32
REC967344	313446	3 3/8	3 5/8	1/8
REC313754	313754	1 7/8	2 1/16	3/32
REC314491	314491	1	1 1/8	1/16
REC314728	314728	2 1/8	2 5/16	3/32
REC332583	317178	1/4	3/8	1/16
REC318372	318372	8 mm	16 mm	4 mm
REC318717	318717	1 1/2	1 7/8	3/16
REC319085	319085	1 1/8	1 1/2	3/16
REC0319662	319662	1 13/16	2	3/32
REC320140	320140	15/16	1 3/16	1/8
REC925093	320303	2 3/4	3	1/8
REC25-25007	321117	3/16	5/16	1/16
REC331188	322501	1 5/16	1 1/2	3/32
REC25-38933	322598	7/32	11/32	1/16
REC326649	326649	5/8	13/16	3/32
REC326741	326741	4 1/2	4 3/4	1/8
REC326849	326849	4 1/4	4 1/2	1/8
REC301877	326959	31/128	73/128	21/128
REC326649	329380	5/8	13/16	3/32
REC3852045	329381	3/8	9/16	3/32
REC332583	332583	1/4	3/8	1/16
REC332583	332584	1/4	3/8	1/16
REC333572	333572	1/4	7/16	3/32
REC338518	338518	2 9/16	2 3/4	3/32
REC338522	338522	1 5/8	1 3/16	3/32
REC339543	339543	1/2	11/16	3/32
REC553126	553126	3 1/4	3 1/2	1/8
REC0554545	554545	1 1/8	1 5/16	3/32

Ref.	R.O. OEM	Ø int	Ø ext	Grueso Thick Spessore
REC908194	908194	4	4 3/16	3/32
REC908383	908383	2 1/2	2 11/16	3/32
REC326649	909047	5/8	13/16	3/32
REC909048	909048	1/2	11/16	3/32
REC909139	909139	1	1 1/4	1/8
REC909140	909140	1 1/16	1 3/16	1/16
REC909316	909316	1 1/2	1 11/16	3/32
REC3852045	909747	5/16	1/2	3/32
REC910238	910238	5 1/4	5 1/2	1/8
REC25-30224	910582	1 7/8	2 1/8	1/8
REC332583	911311	1/4	3/8	1/16
REC25-70937	911686	3 1/2	3 3/4	1/8
REC911700	911700	4 1/8	4 3/8	1/8
REC3852535	911718	1 1/16	1 1/4	3/32
REC309731	911871	1 3/16	1 3/8	3/32
REC25-25439	3852565	7/8	1 1/16	3/32
REC25-25007	321117	3/16	5/16	1/16
REC25-38933	307853	7/32	11/32	1/16
REC25-38933	322598	7/32	11/32	1/16
REC332583	305739	1/4	3/8	1/16
REC332583	317178	1/4	3/8	1/16
REC332583	332583	1/4	3/8	1/16
REC332583	332584	1/4	3/8	1/16
REC332583	911311	1/4	3/8	1/16
REC25-62702	303191	5/16	7/16	1/16
REC25-48171	202893	3/8	1/2	1/16
REC307450	307450	7/16	9/16	1/16
REC304174	304174	1/2	5/8	1/16
REC25-62705	311338	3/4	7/8	1/16
REC314491	314491	1	1 1/8	1/16
REC909140	909140	1 1/16	1 13/16	1/16
REC909048	909048	1/2	11/16	3/32
REC333572	333572	1/4	7/16	3/32
REC3852045	909747	5/16	1/2	3/32
REC3852045	303067	3/8	9/16	3/32
REC3852045	329381	3/8	9/16	3/32
REC303347	303347	7/16	5/8	3/32
REC339543	339543	1/2	11/16	3/32
REC326649	326649	5/8	13/16	3/32
REC326649	329380	5/8	13/16	3/32
REC326649	909047	5/8	13/16	3/32
REC25-30613	310585	3/4	15/16	3/32
REC25-30613	310967	3/4	15/16	3/32
REC301967	301967	13/16	1	3/32
REC25-29845	308624	15/16	1 1/8	3/32
REC3852535	911718	1 1/16	1 1/4	3/32
REC0554545	554545	1 1/8	1 5/16	3/32
REC309731	309731	1 3/16	1 3/8	3/32
REC309731	911871	1 3/16	1 3/8	3/32
REC331188	322501	1 5/16	1 1/2	3/32
REC302537	302537	1 3/8	1 9/16	3/32
REC25-457101	308626	1 7/16	1 5/8	3/32
REC909316	909316	1 1/2	1 11/16	3/32
REC338522	338522	1 5/8	1 13/16	3/32
REC313340	313340	1 11/16	1 7/8	3/32
REC0319662	319662	1 13/16	2	3/32
REC313754	313754	1 7/8	2 1/16	3/32
REC314728	314728	2 1/8	2 5/16	3/32
REC308876	308876	2 1/4	2 7/16	3/32
REC908383	908383	2 1/2	2 11/16	3/32
REC338518	338518	2 9/16	2 3/4	3/32

Ref.	R.O. OEM	Ø int	Ø ext	Grueso Thick Spessore
REC908194	908194	4	4 <sup>3/16</sup>	3/32
REC909139	909139	1	1 <sup>1/4</sup>	1/8
REC305242	305242	5/16	9/16	1/8
REC310584	310584	3/4	1	1/8
REC320140	320140	15/16	1 <sup>3/16</sup>	1/8
REC125017	302540	1	1 <sup>1/4</sup>	1/8
REC25-35027	303360	1 <sup>1/16</sup>	1 <sup>5/16</sup>	1/8
REC3852928	305270	1 <sup>5/8</sup>	1 <sup>7/8</sup>	1/8
REC302588	302588	1 <sup>3/4</sup>	2	1/8
REC25-30224	310327	1 <sup>7/8</sup>	2 <sup>1/8</sup>	1/8
REC25-30224	910582	1 <sup>7/8</sup>	2 <sup>1/8</sup>	1/8
REC25-33145	302337	2	2 <sup>1/4</sup>	1/8
REC308627	308627	2 <sup>1/4</sup>	2 <sup>1/2</sup>	1/8
REC25-80863	307082	2 <sup>5/8</sup>	2 <sup>7/8</sup>	1/8
REC925093	320303	2 <sup>3/4</sup>	3	1/8
REC25-35029	308621	3 <sup>1/8</sup>	3 <sup>3/8</sup>	1/8

Ref.	R.O. OEM	Ø int	Ø ext	Grueso Thick Spessore
REC553126	553126	3 <sup>1/4</sup>	3 <sup>1/2</sup>	1/8
REC967344	313446	3 <sup>3/8</sup>	3 <sup>5/8</sup>	1/8
REC25-70937	911686	3 <sup>1/2</sup>	3 <sup>3/4</sup>	1/8
REC310414	310141	3 <sup>5/8</sup>	3 <sup>7/8</sup>	1/8
REC305123	305123	3 <sup>3/4</sup>	4	1/8
REC911700	91170	4 <sup>1/8</sup>	4 <sup>3/8</sup>	1/8
REC326849	326849	4 <sup>1/4</sup>	4 <sup>1/2</sup>	1/8
REC326741	326741	4 <sup>1/2</sup>	4 <sup>3/4</sup>	1/8
REC313175	313175	4 <sup>3/4</sup>	5	1/8
REC910238	910238	5 <sup>1/4</sup>	5 <sup>1/2</sup>	1/8
REC301877	301877	31/128	73/128	21/128
REC301877	326956	31/128	73/128	21/128
REC319085	319085	1 <sup>1/8</sup>	1 <sup>1/2</sup>	3/16
REC318717	318717	1 <sup>1/2</sup>	1 <sup>7/8</sup>	3/16
REC318372	318372	8 mm	16 mm	4 mm

**GUÍA RETENES ACEITE  
OIL SEALS GUIDE  
GUIDA PARAOLIO**

Ref.	R.O. OEM	Eje Shaft size Asse	Calibre Bore size Calibre
REC302564	302564	0.7813	1.3750
REC303345	303345	0.5625	1.0000
REC767970	305987	1.0000	1.3750
REC309989	309989	1.3750	2.0000
REC310599	310599	1.0000	1.500
REC310649	310649	2.500	3.0000
REC313282	313282	0.5540	1.065
REC313284	313284	0.6250	1.1250
REC313353	313353	1.9375	2.4375
REC26-419533	313392	1.1875	1.8750
REC314167	314167	0.4219	0.9375
REC318972	318972	0.50000	0.8750
REC26-76868	320862	1.1875	1.6875
REC26-69188	321453	0.8750	1.2500
REC321459	321459	0.6250	1.1250
REC321466	321466	0.7500	1.1250
REC321467	321467	1.0000	1.3750
REC321480	321480	0.5000	1.2500
REC321481	321481	0.6875	1.2500
REC321786	321786	0.6250	1.1250
REC321787	321787	0.6250	1.1250
REC321788	321788	0.5000	1.0000
REC321831	321831	0.7500	1.2500
REC321895	321895	1.625	1.9219
REC321928	321928	0.5260	1.3750
REC324639	324639	0.4375	0.9375
REC327031	327031	0.4375	0.8750
REC329922	329922	0.8750	1.3750
REC329923	329923	0.8750	1.3750
REC330137	330137	1.1250	1.6250
REC330327	330327	0.6250	1.1250
REC331103	331103	1.1250	1.6250
REC342786	332205	0.7500	1.1250
REC332261	332261	0.6250	1.3750
REC353076	353076	1.6250	2.0625
REC334950	334950	1.2500	1.6875
REC339620	339620	1.6250	2.1250
REC341280	341280	0.8750	1.3750
REC341281	314281	1.2500	1.6875
REC908855	908855	0.6250	1.0000
REC911019	911019	1.0000	2.5000
REC911685	911685	2.0000	2.5000
REC981195	981195	1.5000	2.1250
REC981196	981196	1.750	2.5000
REC981268	981268	1.6250	2.5000
REC3852272	3852272	45 mm	75 mm
REC3853655	3853655	0.5000	0.9062
REC853868	3853858	25 mm	35 mm

Ref.	R.O. OEM	Eje Shaft size Asse	Calibre Bore size Calibre
REC314167	314167	0.4219	0.9375
REC327031	327031	0.4375	0.8750
REC324639	324639	0.4375	0.9375
REC29-47270	318972	0.5000	0.8750
REC321480	321480	0.5000	1.2500
REC321788	321788	0.5000	1.0000
REC3853655	3853655	0.5000	0.9062
REC313282	313282	0.5540	1.0625
REC303345	303345	0.5625	1.0000
REC313284	313284	0.6250	1.1250
REC321459	321459	0.6250	1.1250
REC321787	321787	0.6250	1.1250
REC321928	321928	0.6250	1.3750
REC330327	330327	0.6250	1.1250
REC321786	321786	0.6250	1.1250
REC332261	332261	0.6250	1.3750
REC908855	908855	0.6250	1.0000
REC321481	321481	0.6875	1.2500
REC321466	321466	0.7500	1.1250
REC342786	332205	0.7500	1.1250
REC321831	321831	0.7500	1.2500
REC302564	302564	0.7813	1.3750
REC26-69188	321453	0.8750	1.2500
REC341280	341280	0.8750	1.3750
REC329922	329922	0.8750	1.3750
REC329923	329923	0.8750	1.3750
REC853868	3853858	25 mm	35 mm
REC310599	310599	1.0000	1.5000
REC321467	321467	1.0000	1.3750
REC911019	911019	1.0000	2.5000
REC767970	305987	1.0000	1.3750
REC330137	330137	1.250	1.6250
REC331103	331103	1.1250	1.6250
REC26-419533	313392	1.1875	1.8750
REC26-76868	3286	1.1875	1.6875
REC341281	314218	1.2500	1.6875
REC334950	334950	1.2500	1.6875
REC309989	309989	1.3750	2.0000
REC981195	981195	1.5000	2.1250
REC981268	981268	1.6250	2.5000
REC339620	339620	1.6250	2.1250
REC353076	353076	1.6250	2.0625
REC321895	321895	1.6250	1.9219
REC981196	981196	1.7500	2.5000
REC3852272	3852272	45 mm	75 mm
REC313353	313353	1.9375	2.4375
REC911685	911685	2.0000	2.5000
REC310649	310649	2.5000	3.0000

**APLICACIÓN DE RETENES COBRA  
COBRA SEALS APPLICATIONS  
APPLICAZIONI PARAOLI COBRA**

Motor Engine Motore	Año Year Anno	Ref.	Descripción	Description	Descrizione	Cantidad Quantity Quantità
<b>TRANSOM</b>						
262 - 460	1988-90	REC3852548	EJE	DRIVESHAFT	ASSE	1
<b>PARTE SUPERIOR / UPPER GEARCASE / PARTE SUPERIORE</b>						
262 - 460	1988-90	REC911685	COJINETE	BEARING CARRIER	CUSCINETTO	1
350 - 460	1988-90	REC3853655	EJE BOMBA	PUMP SHAFT	ASSE POMPA	1
2.3 L - 7.5 L	1986-88	REC3853655	EJE BOMBA	PUMP SHAFT	ASSE POMPA	1
2.3 L - 7.5 L	1986-90	REC911685	COJINETE	BEARING CARRIER	CUSCINETTO	1
5.7 L (1990) 574 AMPWS, ARPWS						
<b>PARTE INFERIOR / LOWER GEARCASE / PARTE INFERIORE</b>						
262 - 460	1988-89	REC26-76868	EJE HÉLICE	PROP SHAFT	ASSE ELICA	2
2.3 L	1990	REC330137	EJE HÉLICE	PROP SHAFT	ASSE ELICA	2
2.3 L - 3.0 L	1986-89	REC330137	EJE HÉLICE	PROP SHAFT	ASSE ELICA	2
3.0 L	1990	REC26-76868	EJE HÉLICE	PROP SHAFT	ASSE ELICA	2
4.3 L - 7.5 L	1986-90	REC26-76868	EJE HÉLICE	PROP SHAFT	ASSE ELICA	2

**GUIA CORREAS  
V-BELTS GUIDE  
GUIDA CINGHIE**

Modelo Model Modello	Años Year Anni	Bomba agua Water Pump Pompa acqua	Dirección Hidráulica Power Steering Idroguida	Alternador Alternator Alternatore	REF	R.O. OEM	Modelo Model Modello	Años Year Anni	Bomba agua Water Pump Pompa acqua	Dirección Hidráulica Power Steering Idroguida	Alternador Alternator Alternatore	REF	R.O. OEM
120	175						235	1971	✓		✓	REC3858462	311046
140	190							1975-77	✓		✓	REC3852106	311606
145	235						240	1975-84	✓		✓	REC3852106	311606
165	240	✓		✓	REC3852106	311606	250	1979	✓		✓	REC3852106	311606
170							245 Jet Drive	1973-75	✓		✓	REC3852106	311606
4 151 Gasolina / Fuel / Benzina									✓		✓	REC57-48122Q	3852504
140		✓		✓	REC829207	310953			✓		✓	REC3852106	311606
155	235						262 King Cobra 4.3L (V-6 262)	1989	✓	✓		REC3852464	3852464
185	240								Salada Sea Salata			GDY15386	910414
210	245						290 Jet Drive	1974-75	✓		✓	REC3858462	311046
215	250	✓		✓	REC3858462	311046			✓		✓	REC3858462	311046
225	260								46" Salada Sea Salata			REC3852464	3852464
230							305 V-8 305 Gasolina / Fuel / Benzina	1977-84	✓				
V-6, V-8									50" Salada Sea Salata			REC57-96834Q	912714
165	1972-76	✓		✓	REC3852106	311606	325 390 V-8 427				✓	REC57-48122Q	
165C, 165S 40-1/4"		✓		✓	REC3858462				✓		✓	REC3858462	311046
170	1974	✓		✓	REC3852106	311606	350 V-8 350 Gasolina / Fuel / Benzina	1977-84	46" Salada Sea Salata			REC3852464	3852464
175	1975-77	✓		✓	REC3852106	311606			50" Salada Sea Salata			REC57-96834Q	912714
185	1978-84	✓	✓	✓	REC829207	909971	350 King Cobra 5.7L (V-8 350) Gasolina / Fuel / Benzina	1988	✓		✓	REC3852464	3852464
190	1974-77	✓	✓	✓	REC829207	909971			✓		✓	REC57-48122Q	3852504
190		✓			REC3852106	311606			✓		✓	REC57-78200Q1	3852504
225		✓			REC3858462		370 V-8 454 Gasolina / Fuel / Benzina		✓	✓		GDY15386	910414
44-1/4"		✓			REC3858462				Salada Sea Salata			REC57-48122Q	3852504
200	1979-81	✓		✓	REC3858462	311046			✓		✓	REC3852464	3852464
210	1970-71	✓		✓	REC829207	909971			✓				
215		✓		✓	REC3858462	311046			✓				
V-8 302 Ford Gasolina / Fuel / Benzina	1971	✓		✓	REC966382				✓				
225	1972-84	✓		✓	GDY17335				✓				
250	1973	✓		✓	REC3858462	311046			✓				
		✓		✓	REC3858462	311046			✓				
	1979-81	✓	✓	✓	REC829207	909971			✓				
230		✓	✓	✓	REC829207	909971			✓				
260	1975	✓		✓	REC3858462	311046	454 V-8 454 Gasolina / Fuel / Benzina	1977-82	Salada Sea Salata		✓	REC3852464	3852464
		Salada Sea Salata			REC3852464	3852464			✓			REC57-96834Q	912714

Modelo Model Modello	Años Year Anni	Bomba agua Water Pump Pompa acqua	Dirección Hidráulica Power Steering Idroguida	Alternador Alternator Alternatore	REF	R.O. OEM
454 King Cobra V-8 454 Gasolina / Fuel / Benzina		✓	✓		REC57- 78200Q1	3852504
			✓		GDY15386	910414
		Salada Sea Salata			REC57-48122Q	3852504
460 King Cobra 7.5L (V-8 460)	1988	✓		✓	REC829207	909971
		✓	✓		REC57-34359	912714
888 V-8 427		✓		✓	REC966382	
2.3L "4" 140		✓	✓	✓	REC966382	912509
		✓		✓	REC966382	912509
2.5L, 3.0L 181		✓		✓	REC57-36356	910343
2.5L (1982-87)			✓	✓	REC3852106	311606
3.0L 181 (1982-89)			✓		REC829207	909971
3.8L (V-6 229)		✓		✓	REC57-48122Q	3852504
4.3L (V-6 262)		✓		✓	REC3852106	311606
3.8L (V-6 229) (1982-86)		✓	✓		REC3852464	3852464
4.3L (V-6 262) (1982-89)		Salada Sea Salata			GDY15386	910414

Modelo Model Modello	Años Year Anni	Bomba agua Water Pump Pompa acqua	Dirección Hidráulica Power Steering Idroguida	Alternador Alternator Alternatore	REF	R.O. OEM
5.0L (V-8 305)		✓		✓	REC3852464	3852464
5.7L (V-8 350)		✓	✓	✓	REC57-48122Q	3852504
5.0L (V-8 305) (1982-87)			✓		REC3852464	3852464
5.7L (V-8 350) (1982-90)		Salada Sea Salata			GDY15386	910414
5.0L (V-8 302)		✓		✓	REC3852106	311606C
5.7L (V-8 351)						
5.0L (V-8 305) (1988)		✓	✓	✓	REC3858462	3858462
5.8L (V-8 351)						
7.5L (V-8 460)	1987	✓		✓	REC829207	909971
		✓	✓		REC57-34359	912714

## COMPONENTES DE COLA GEARHOUSING COMPONENTS COMPONENTI PIEDE

### ACOPLAMIENTOS COUPLERS PARASTRAPPI

Ref.	R.O. OEM	AGUJERO HOLE FUORI	CUBO SALIDA HUB OUTER CUBO
REC3853962	3853962	Ø 91 mm	Ø 43 mm

#### MOTORES / ENGINES / MOTORI

2.5L (1986)  
3.0L (1986-90),  
4.3L, 5.0L, 5.7L (1986) KX & KWB  
7.4L (1990-98),  
8.2L (1992-93, 1998)



Ref.	R.O. OEM	AGUJERO HOLE FUORI	CUBO SALIDA HUB OUTER CUBO
REC3858437	3853917	Ø 76 mm	Ø 43 mm

#### MOTORES / ENGINES / MOTORI

4.3L (1986-98), 5.0L (1986-88, 1998),  
5.7 (1986-92, 1994, 1996-98)



### FUELLES CABLE CAMBIO SHIFT CABLE BELLOWS CUFFIE CAMBIO

Ref.	R.O. OEM
CEF500506	911826

#### MOTORES / ENGINES / MOTORI

Cobra 1986-93



### FUELLES TRANSON TRANSON BELLOWS CUFFIE TRANSON

Ref.	R.O. OEM
REC3841481	3854127
CEF500514K	3854127

#### MOTORES / ENGINES / MOTORI

Cobra 1986-98



### FUELLES ESCAPE EXHAUST BELLOWS CUFFIE SCARICO

Ref.	R.O. OEM
REC914036	914036
CEF500527K	914036

#### MOTORES / ENGINES / MOTORI

Cobra 1986-93





Ref.	R.O. OEM
REC912374	912374
CEF500521K	912374

**MOTORES / ENGINES / MOTORI**

7.5 (460) 1987,  
5.0-5.8 Ford 1989-90,  
5.7 1986,  
5.7 1987-1988.

Manguito superior / Upper hose / Manicotto superiore



Ref.	R.O. OEM
REC3863450	3852741

**MOTORES / ENGINES / MOTORI**

2.5 1986  
3.0 1986-91  
2.3 1989-90  
4.3 1990-91  
5.0-5.8 Ford 1991  
5.7 1986.

Manguito inferior / Lower hose / Manicotto inferiore



Ref.	R.O. OEM
REC3852696	3852696

**MOTORES / ENGINES / MOTORI**

4.3 1991,  
5.0-5.8 Ford 1991,  
7.5 (460) 1988-89,  
5.7LE 1990-91



Ref.	R.O. OEM
REC3852742	3852742

**MOTORES / ENGINES / MOTORI**

2.3/4.3/5.0/5.7/5.8L (1989-91)  
2.3 1987-88,  
4.3 1987-89,  
5.0-5.8 Ford 1989-90,  
5.7 1986,  
5.7 1987-91,  
1990-91 (350/454/454HO/460 King, 5.7LE  
1990-91. Manguito inferior / Lower hose / Manicotto inferiore



**KIT PIÑONES Y DESPLAZABLES  
GEAR SETS & CLUTCH DOGS  
KIT PIGNONI E SLETTORI**

**KIT PIÑONES ESTANDAR COMPLETO Y DESPLAZABLE 14:26  
COMPLETE GEAR SET & CLUTCH DOG 14:26  
KIT PIGNONI COMPLETO DI SELETTORE 14:26**

Ref.	R.O. OEM
REC5004218	986980



**DESPLAZABLE  
CLUTCH DOG  
SELETTORE**

Ref.	R.O. OEM	MOTOR ENGINE MOTORE	AÑO YEAR ANNO
REC337774	912607	3.8L/229CI V6	1981-85
		4.3L/262CI V6	1985
		5.0L/305CI V8	1981-85
		5.7L/350CI V8	1981-85



**4 CYL.  
3.0L (1986-89)  
2.3L (1987-90)**

**KIT PIÑONES ESTANDAR COMPLETO Y DESPLAZABLE 13:26  
COMPLETE GEAR SET & CLUTCH DOG 13:26  
KIT PIGNONI COMPLETO DI SELETTORE 13:26**

Ref.	R.O. OEM
REC986979	986979



**DESPLAZABLE  
CLUTCH DOG  
SELETTORE**

Ref.	R.O. OEM
REC323664	910578 323664



**KIT ENGRANAJES TRANSOM  
BALL GEAR KIT. TRANSOM  
KIT ENGRANAGGI TRANSOM**

Ref.	R.O. OEM
REC22050	



REF	R.O. OEM	Descripción	Description	Descrizione	Cantidad Quantity
REC25-35029	308621	ARO	O-RING	ANELLO	1
REC908062	908062	TAPA	BALL GEAR COVER	COPERCHIO	2
REC908063	908063	ENGRANAJE	BALL GEAR	INGRANAGGIO	1
REC908064	908064	TUERCA	NUT	DADO	2
REC908069	321467	ENGRANAJE	BALL GEAR	INGRANAGGIO	1
REC908383	908383	ARO	O-RING	ANELLO	1
REC981195	981195	RETÉN	OIL SEAL	PARAOILIO	2
REC981196	981196	RETÉN	OIL SEAL	PARAOILIO	2

**CABLE CAMBIO  
SHIFT CABLE  
CAVO CAMBIO**

Ref.	R.O. OEM
REC987661	987661



Ref.	R.O. OEM
REC987678	985518
	986423
	987604
	987678

**MOTORES / ENGINES / MOTORI  
KING COBRA**



**CABLE CAMBIO ELECTRICO  
ELECTRIC SHIFT CABLE  
CAVO CAMBIO ELETTRICO**

Ref.	R.O. OEM
REC379628	379628



**CRUCETAS CARDAN  
U-JOINTS  
CROCIERA**

Ref.	R.O. OEM
REC75832T	912214



**EJES TRANSMISIÓN  
DRIVE SHAFTS  
ASSE TRASMISSIONE**

Ref.	R.O. OEM
REC909121	909121



Ref.	R.O. OEM
REC981220	981220

**MOTORES / ENGINES / MOTORI  
V8 - V6**



Ref.	R.O. OEM
REC382883	382883

**MOTORES / ENGINES / MOTORI  
4 CIL.**



Ref.	R.O. OEM
REC915716	915716



Ref.	R.O. OEM
REC3850812	3850812



**EJE HÉLICE CON CAMBIO MECÁNICO  
PROP SHAFT WITH MECHANICAL SHIFT  
ASSE ELICA CON CAMBIO MECCANICO**



REC330137



REC26-76868



REC314731



REC382408



REC967344



REC305123



REC379504



REC387247



REC382407



REC436888



REC395209

4 CYL	V6-V8	REF	R.O./OEM	Descripción	Description	Descrizione
✓		REC330137	330137	RETEN ACEITE EJE HELICE	OIL SEAL - PROP SHAFT	PARAOILIO ASSE ELICA
	✓	REC26-76868	320862	RETEN ACEITE EJE HELICE	OIL SEAL - PROP SHAFT	PARAOILIO ASSE ELICA
✓		REC379504	379504	COJINETE ACEITE EJE HELICE	BEARING - PROP SHAFT	CUSCINETTO ASSE ELICA
	✓	REC387247	387247	COJINETE ACEITE EJE HELICE	BEARING - PROP SHAFT	CUSCINETTO ASSE ELICA
✓	✓	REC382407	382407	COJINETE CONTRARROTACIÓN TOPE ARANDELA	REVERSE GEAR BEARING CARRIER	CUSCINETTO CONTROROTANTE
✓	✓	REC314731	314731	CONTRARROTACIÓN TOPE ARANDELA	THRUST WASHER FOR REVERSE GEAR	FERMO CONTROROTANTE
✓	✓	REC382408	382408	CONTRARROTACIÓN TOPE COJINETE	THRUST BEARING FOR REVERSE GEAR	FERMO CUSCINETTO CONTROROTANTE
✓		REC967344	313446	ARO TÓRICO	O-RING	ANELLO
✓	✓	REC305123	305123	ARO TÓRICO	O-RING	ANELLO
✓		REC436888	436888	EJE HÉLICE	PROP SHAFT	ASSE ELICA
	✓	REC395209	395209	EJE HÉLICE	PROP SHAFT	ASSE ELICA

**CIERRES HÉLICE  
PROP HARDWARE  
CHIUSURA ELICA**

**STRINGER 800 COBRA V (1978-87)  
COBRA & KING COBRA (1992-93)  
COBRA, KING & SX (1994+)**

**TOPES  
THRUST WASHERS  
FERMI**

Ref.	R.O. OEM
REC126870	126870

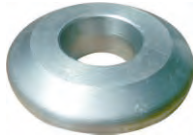

**ESPACIADOR  
SPACER  
DISTANZIALE**

Ref.	R.O. OEM
REC320570	320570



**MOTORES / ENGINES / MOTORI**  
Stringer 800 Cobra V (1978-87)  
Cobra & King Cobra (1992-93)

Ref.	R.O. OEM
REC3852350	3852350



**MOTORES / ENGINES / MOTORI**  
Cobra, King & SX (1994+)

**PASADOR  
COTTER PIN  
CHIAVISTELLI**

Ref.	R.O. OEM
REC3852056	306394



**KITS**

Ref.	R.O. OEM
REC398042	5008966



Ref.	R.O. OEM
REC175266	175266

**MOTORES / ENGINES / MOTORI**  
Stringer 800 Cobra V (1978-87)  
Cobra & King Cobra (1992-93)



Ref.	R.O. OEM
REC414153	434153

**MOTORES / ENGINES / MOTORI**  
Stringer 800 Cobra V (1978-87)  
Cobra & King Cobra (1992-93)

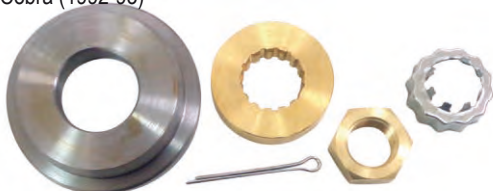

Ref.	R.O. OEM
REC22188	REC3852350 + REC398042

**MOTORES / ENGINES / MOTORI**  
Cobra, King & SX (1994+)



**STRINGER 400 DRIVES  
COBRA 4 CIL (1978-89)  
COBRA 2.3L (1990)**

**TOPES  
THRUST WASHERS  
FERMI**

Ref.	R.O. OEM
REC127084	127084

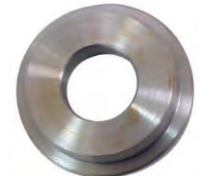

**ESPACIADOR  
SPACER  
DISTANZIALE**

Ref.	R.O. OEM
REC315810	315810



**PASADOR  
COTTER PIN  
CHIAVISTELLI**

Ref.	R.O. OEM
REC314502	314502



**TUERCA  
NUTS  
DADO**

Ref.	R.O. OEM
REC314503	314503



**KITS**

Ref.	R.O. OEM
REC175267	175267



Ref.	R.O. OEM
REC5005034	5005034

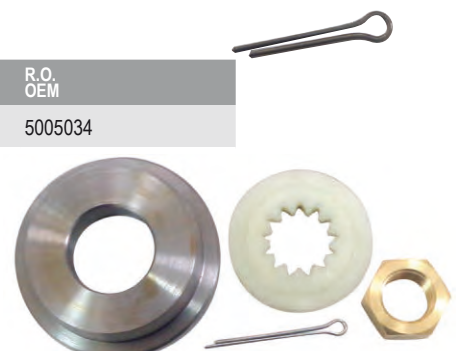

# HERRAMIENTAS COLAS STERNDRIVES TOOLS ATTREZZATURA PIEDI

## ALINEACION MOTOR ENGINE ALIGNMENT TOOL ALLINEAMENTO MOTORE

Ref.	R.O. OEM
REC91-805475A1	912273



## ÁNODOS ANODES ANODI

ZN	KG (kg)	AL	KG (kg)	R.O. OEM	MOTORES ENGINES MOTORI
CM3855411	1,04	CM3855411A	0,41	3855411	COBRA (1994-98)



ZN	KG (kg)	AL	KG (kg)	R.O. OEM	MOTORES ENGINES MOTORI
CM984513	0,97	CM984513A	0,38	3853818	COBRA (1986-93)



ZN	KG (kg)	AL	KG (kg)	R.O. OEM	MOTORES ENGINES MOTORI
CM983494	0,82	CM983494A	0,32	983494	400-800 (1978-85) COBRA (1986-93)



ZN	KG (kg)	AL	KG (kg)	R.O. OEM	MOTORES ENGINES MOTORI
CM431708	0,27	CM431708A	0,24	431708	400-800 (1978-85) COBRA (1986-93)



ZN	KG (kg)	AL	KG (kg)	R.O. OEM	MOTORES ENGINES MOTORI
CM397768	0,31	CM397768A	0,12	397768	



ZN	KG (kg)	AL	KG (kg)	R.O. OEM	MOTORES ENGINES MOTORI
CM984547	0,91	CM984547A	0,35	984547	COBRA



ZN	KG (kg)	AL	KG (kg)	R.O. OEM	MOTORES ENGINES MOTORI
CM976669	0,43	CM976669A	0,17	976669	



ZN	KG (kg)	AL	KG (kg)	R.O. OEM	MOTORES ENGINES MOTORI
CM982438	0,83		1,07	982438	100-245 HP



ZN	KG (kg)	AL	KG (kg)	R.O. OEM	MOTORES ENGINES MOTORI
CM393023	0,22	CM393023A	0,09	436745	400-800 (1978-85) COBRA (1986-93)



ZN	KG (kg)	SÓLO ÁNODO ANODE ONLY SOLO ANODO	KG (kg)	R.O. OEM	MOTORES ENGINES MOTORI
CMCC	0,93	CMC	0,45		COBRA



ZN	R.O. OEM	KG (kg)	MOTORES ENGINES MOTORI
TEN00920	3854061	0,98	COBRA 5700



ZN	R.O. OEM	KG (kg)	MOTORES ENGINES MOTORI
TEN00919	3853930	0,61	TRANSOM COBRA (1986-93)



# HÉLICES ALUMINO E INOXIDABLES DE 3 Y 4 PALAS 3 & 4 BLADE ALUMINUM & STAINLESS STEEL PROPELLERS ELICHE ALLUMINIO E INOX DA 3 E 4 PALE

SISTEMA CODIGO REFERENCIAS  
PART NO. CODING SYSTEM  
SISTEMA DI CODICE

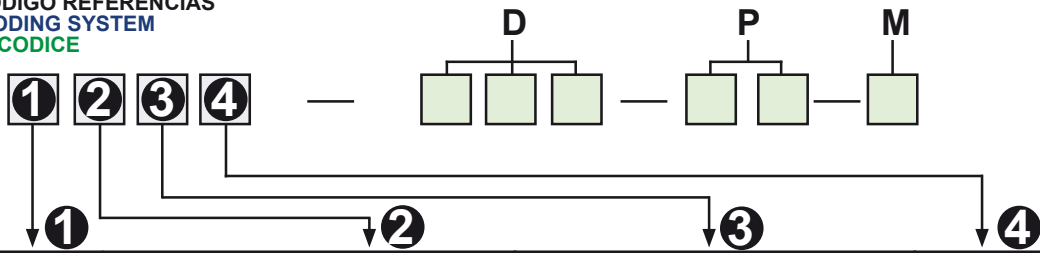

<p>1. Mercury, Mariner 2. Johnson, Evinrude 3. Yamaha 4. Suzuki 5. Tohatsu 6. 7. 8. Volvo Penta 9. Rubex System</p>	<p>0.5,6,8 and 9.8 HP Grupo /Group / Gruppo 1. A Grupo /Group / Gruppo 2. B Grupo /Group / Gruppo 3. C Grupo /Group / Gruppo 4. D Grupo /Group / Gruppo 5. E Grupo /Group / Gruppo 6. F Grupo /Group / Gruppo 7. VP (Cubo std./Std. Hub / mozzo std.) 8. VP (Cubo largo /Long Hub / mozzo lungo)</p>	<p>1. Aluminio /Aluminum / Alluminio 2. Saturn Acero inox. /S.S. / Acciaio inox. 3. New Saturn Acero inox. /S.S. / Acciaio inox. 4. Titan Acero inox. /S.S. / Acciaio inox. 5. HR Titan Acero inox. /S.S. / Acciaio inox.</p>	<p>1. 3R Rubber Hub 2. 3L Rubber Hub 3. 4R Rubber Hub 4. 4L Rubber Hub</p>
---	--	---	--

Ejemplo / Note / Esempio

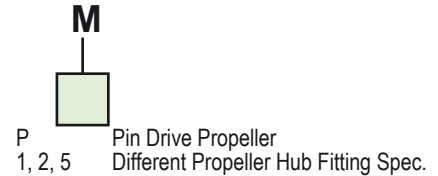
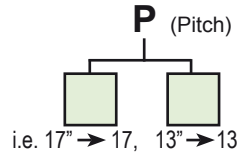
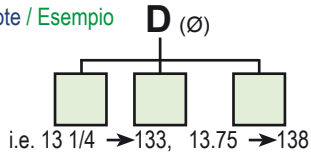

## SOLAS AMITA 3



- Helices de aluminio de 3 palas con núcleo de goma de gran resistencia.
- 3 blade aluminum propeller with heavy duty rubber hub.
- Eliche in alluminio a 3 pale con mozzi in gomma ad alta resistenza.

## SOLAS AMITA 4



- Helices de aluminio de 4 palas con núcleo de goma de gran resistencia.
- Van muy suaves a poca velocidad y hace el barco muy manejable con la mar picada.
- 4 Blade aluminum propeller with heavy duty rubber hub.
- Smoother low speed makes the offshore boating activity much easier.
- Eliche in alluminio a 4 pale con mozzo in gomma ad alta resistenza.
- Ideale per basse velocità, rendono l'imbarcazione molto maneggevole anche con mare mosso.

## SOLAS HR TITAN 3 PROP



- Hélice de acero inoxidable de 3 palas.
- Alto rendimiento para cascos de alta velocidad.
- La inclinación de la hoja proporciona un excelente elevación de proa y aceleración.
- El diseño de copa grande aumenta la mordida y reduce el deslizamiento.
- Three blade stainless steel propeller.
- Performance prop for high speed planning hulls.
- High rake blade design provides excellent bow lift and acceleration.
- Heavy cup design increases bite and reduces slip.
- Eliche di acciaio inox a 3 pale.
- Alte prestazioni per scafi ad alta velocità.
- Il passo della pala fornisce un'eccellente elevazione e accelerazione.
- Il disegno della coppa aumenta le prestazioni e riduce lo slittamento.

## SOLAS NEW SATURN PROP

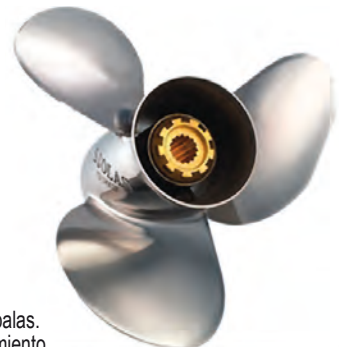

- Helices de acero inoxidable de 3 palas.
- Ofrece buena aceleración y rendimiento.
- Tamaño más pequeño que ofrece un diámetro extragrande.
- Three blade stainless steel propeller.
- Offers good acceleration & all-round performance.
- Smaller pitch sizes offered in extra large diameter with increased blade area.
- Eliche in acciaio inox a 3 pale.
- Consentono buone accelerazioni.
- Con un'area più ampia nelle pale.

HP	R.O. OEM	B	D	P	R	TIPO TYPE	ALUMINIO ALUMINIUM ALLUMINIO		INOX STAINLESS STEEL INOX	
							AMITA 3	AMITA 4	NEW SATURN	HR TITAN 3
MOD 400	382761	3	14	11	R	Alum.	SOL2411-140-11			
2,3 L - 3,0 L	765181	3	13 <sup>3/4</sup>	13	R	Alum.	SOL2411-138-13	SOL2413-133-13		
COBRA	765182	3	13 <sup>1/2</sup>	15	R	Alum.	SOL2411-135-15	SOL2413-130-15	SOL2431-135-15	
2,3 L - 3,0 L	765183	3	13 <sup>1/4</sup>	17	R	Alum.	SOL2411-133-17	SOL2413-128-17	SOL2431-133-17	
	765184	3	13	19	R	Alum.	SOL2411-130-19	SOL2413-125-19	SOL2431-130-19	
MOD 800	765186	3	15 <sup>1/4</sup>	15	R	Alum.	SOL2511-150-15	SOL2513-148-15	SOL2531-145-15	
COBRA		3	15 <sup>1/4</sup>	15	L	Alum.	SOL2512-150-15	SOL2514-148-15	SOL2532-145-15	
KING COBRA	765187	3	15	17	R	Alum.	SOL2511-148-17	SOL2513-145-17	SOL2531-143-17	
3,0 L & 8,2 L		3	15	17	L	Alum.	SOL2512-148-17	SOL2514-145-17	SOL2532-143-17	
	765188	3	14 <sup>4/5</sup>	19	R	Alum.	SOL2511-145-19	SOL2513-143-19	SOL2531-140-19	
15 Estrias / Spline / denti		3	14 <sup>4/5</sup>	19	L	Alum.	SOL2512-145-19	SOL2514-143-19	SOL2532-140-19	
	391202	3	14 <sup>1/2</sup>	21	R	Alum.	SOL2511-143-21		SOL2531-140-21	
		3	14 <sup>1/2</sup>	21	L	Alum.	SOL2512-143-21		SOL2532-140-21	
	391203	3	14 <sup>1/4</sup>	23	R	Alum.	SOL2511-142-23	SOL2513-140-23	SOL2531-140-23	
		3	14 <sup>1/4</sup>	23	L	Alum.	SOL2512-142-23		SOL2532-140-23	
3,0 L	763315	3	15	15	R	Alum.	SOL8611-150-15	SOL8613-148-15		
4,3 L	3855479-6	3	15	15	L	Alum.	SOL8612-150-15	SOL8614-148-15		
5,0 L	763316	3	14.8	17	R	Alum.	SOL8611-148-17	SOL8613-145-17		
5,7 L	3855480-4	3	14.8	17	L	Alum.	SOL8612-148-17	SOL8614-145-17		
5,8 L	3850301-7	3	14.5	19	R	Alum.	SOL8611-145-19	SOL8613-143-19		
7,4 L	3855481-2	3	14.5	19	L	Alum.	SOL8612-145-19	SOL8614-143-19		
	763318	3	14.3	21	R	Alum.	SOL8611-143-21	SOL8613-140-21		
19 Estrias / Spline / Denti		3	14.3	21	L	Alum.	SOL8612-143-21	SOL8614-140-21		
	763319	3	14.2	23	R	Alum.	SOL8611-142-23			
Cola / Drive / Piede SX	763304	3	15	15	R	INOX - SS				SOL8651-148-16
	763305	3	15	15	L	INOX - SS				SOL8652-148-16
	763306	3	15	17	R	INOX - SS				SOL8651-148-17
	763307	3	15	17	L	INOX - SS				SOL8652-148-17
	763308	3	14 <sup>1/2</sup>	19	R	INOX - SS				SOL8651-148-19
	763309	3	14 <sup>1/2</sup>	19	L	INOX - SS				SOL8652-148-19
	763310	3	14 <sup>1/4</sup>	21	R	INOX - SS				SOL8651-145-21
	3850322-3	3	14 <sup>1/4</sup>	21	L	INOX - SS				SOL8652-145-21
	763312	3	14 <sup>1/4</sup>	23	R	INOX - SS				SOL8651-140-24
	763313	3	14 <sup>1/4</sup>	23	L	INOX - SS				SOL8652-140-24

B= PALAS / Blades / Pale  
D= DIÁMETRO / Diametre / Diametro  
P= PASO / Pich / Passo

R=ROTACIÓN / Rotation / Rotazione  
(R) Derecha / Right / DX  
(L) Izquierda / Left / SX

## GUÍA DE NÚCLEOS HUB KIT APLICACION CHAST GUIDA MOZZI



# RUBEX

MODELO MODEL MODELLO	REF. KIT	MODELO HÉLICE PROPELLER TYPE MODELLO ELUCHE
400 Cobra, (1978-91), 13 Estrias / tooth spline / Scalature	SOLRBX-106	D
800 Cobra, King Cobra (1978-90) 15 Estrias / tooth spline / Scalature	SOLRBX-101	E
800 Cobra, King Cobra (1991-94), 15 Estrias / tooth spline / Scalature	SOLRBX-100	E
Cobra SX, (1994+), 19 Estrias / tooth spline / Scalature	SOLRBX-105	E

GUÍA HÉLICES ALUMINIO  
PROPELLERS ALUMINUM CHART  
GUIDA ELICHE ALLUMINIO

Modelo / Model / Modello <b>D</b> 40-140 H.P. 3 PALAS / 3 BLADE / 3 PALE				
B	D	P	R	Ref.
3	14	13	R	SOL9411-138-13
3	14	15	R	SOL9411-135-15
3	13	17	R	SOL9411-133-17
3	13	19	R	SOL9411-132-19

Modelo / Model / Modello <b>E</b> 135-300 H.P. 3 PALAS / 3 BLADE / 3 PALE				
B	D	P	R	Ref.
3	15	15	R	SOL9511-150-15
3	15	17	R	SOL9511-148-17
3	15	19	R	SOL9511-145-19
3	14	21	R	SOL9511-143-21

Modelo / Model / Modello <b>D</b> 40-140 H.P. 4 PALAS / 4 BLADE / 4 PALE				
B	D	P	R	Ref.
4	13,3	13	R	SOL9413-133-13
4	13	15	R	SOL9413-130-15
4	12,8	17	R	SOL9413-128-17
4	13,2	19	R	SOL9413-125-19

Modelo / Model / Modello <b>E</b> 135-300 H.P. 4 PALAS / 4 BLADE / 4 PALE				
B	D	P	R	Ref.
4	14,8	15	R	SOL9513-148-15
4	14,5	17	R	SOL9513-145-17
4	14,3	19	R	SOL9513-143-19
4	14	21	R	SOL9513-140-21



**RUBEX**

Hélice de aluminio con núcleo intercambiable (no incluido).  
Aluminium interchangeable hub propellers (not included).  
Eliche in alluminio con mozzo intercambiabile (non incluso).

GUÍA HÉLICES INOX.  
STAINLESS STEEL PROPELLERS APLICATION CHART  
GUIDA ELICHE INOX

Modelo / Model / Modello <b>D</b> 40-140 H.P. NS3 3 PALAS / 3 BLADE / 3 PALE				
B	D	P	R	Ref.
3	13 <sup>3/4</sup>	13	R	SOL9431-138-13
3	13 <sup>3/4</sup>	13	L	SOL9432-138-13
3	13 <sup>1/2</sup>	15	R	SOL9431-135-15
3	13 <sup>1/2</sup>	15	L	SOL9432-135-15
3	13 <sup>1/4</sup>	17	R	SOL9431-133-17
3	13 <sup>1/4</sup>	17	L	SOL9432-133-17
3	13	19	R	SOL9431-130-19
3	13	19	L	SOL9432-130-19
3	13	21	R	SOL9431-130-21

Modelo / Model / Modello <b>E</b> 135-350 H.P. L3 3 PALAS / 3 BLADE / 3 PALE				
B	D	P	R	Ref.
3	15 <sup>3/4</sup>	15	R	SOL9571-158-15
3	15 <sup>3/4</sup>	15	L	SOL9572-158-15
3	15 <sup>1/2</sup>	17	R	SOL9571-155-17
3	15 <sup>1/2</sup>	17	L	SOL9572-155-17
3	15 <sup>1/4</sup>	19	R	SOL9571-153-19
3	15 <sup>1/4</sup>	19	L	SOL9572-153-19
3	15	21	R	SOL9571-150-21
3	15	21	L	SOL9572-150-21
3	14 <sup>3/4</sup>	23	R	SOL9571-148-23
3	14 <sup>3/4</sup>	23	L	SOL9572-148-23

Modelo / Model / Modello <b>E</b> 90-140 H.P. NS3 3 PALAS / 3 BLADE / 3 PALE				
B	D	P	R	Ref.
3	14 <sup>1/2</sup>	15	R	SOL9531-145-15
3	14 <sup>1/2</sup>	15	L	SOL9532-145-15
3	14 <sup>1/4</sup>	17	R	SOL9531-143-17
3	14 <sup>1/4</sup>	17	L	SOL9532-143-17
3	14	19	R	SOL9531-140-19
3	14	19	L	SOL9532-140-19
3	14	21	R	SOL9531-140-21
3	14	21	L	SOL9532-140-21
3	14	23	R	SOL9531-140-23
3	14	23	L	SOL9532-140-23



**RUBEX**

Hélice de acero inox. con núcleo intercambiable (no incluido).  
Stainless steel interchangeable hub propellers (not included).  
Eliche di acciaio inox con mozzo intercambiabile (non incluso).

# ÍNDICE / TABLE OF CONTENTS / INDICE

## REF-->R.O. / OEM

REF.	R.O. /OEM	PAG	REF.	R.O. /OEM	PAG	REF.	R.O. /OEM	PAG
ARC6211	983318	549	FEL17224		508	PH140-0005	984628	546
ARCVR-404	383440	548	FEL17230		510-511	PH140-0006	984536	546
BA1-312148	312148	531	FEL17232		511	PH140-0006	988013	546
BA1-380446	380446	522	FEL17240		513	PH140-0013	981078	546
BA1-908719	908716	531	FEL17241		514	PH140-0013	982121	546
BA1-910280	910280	522	FEL17242		514	PH140-0013	988217	546
BA1-910384	910384	523-524	FEL17244		514	PH140-0015	3860566	547
BAOMC-1-980959	980959	530	FEL17245		514	PH140-0017-D	3860566	547
BAOMC1-3852347	3852347	528	FEL17248		517	PH140-0017-HT		547
BAOMC1-907885	907885	522-523-524	FEL17249		517	PH140-0020	988217	547
BAOMC1-981462	981462	522	FEL17260	507-512-519-520		PH140-0022	981289	546
BAOMC1-982657	982657	523	FEL17261	507-512-519-520		PH140-0022	982202	546
BAOMC1-984054	984054	524	FEL17268	516-521		PH140-0022-CCW	981288	546
BAOMC20-908014	908014	523	FEL17281	517		PH140-0022-CCW	984982	546
BAOMC20-910380	3850799	523-524	FEL17300	311068	505-522-523	PH200-T009	982058	548
BAOMC20-980536	980536	522	FEL17301	908079	505-524	PH200-T009	982706	548
BAOMC20-980617	980617	530	FEL17302		504-505	PH200-T014	391264	548
BAOMC20-981281	981281	530	FEL17304	3853256	504-505	PH200-T014	393259	548
BAOMC29-314810	314810	533	FEL17310	857177	506	PH200-T014	393988	548
BAOMC29-314810	982201	533	FEL17320	856365	508-510-511-515	PH200-T014	394176	548
BAOMC29-908216	908216	533	FEL17341		515-518	PH200-T014	983019	548
BAOMC29-910303	3854254	533	FEL17342		515-517	PH200-T014	985237	548
BAOMC47-311130	311130	531	FEL17360		507-513-519-520	PH200-T020	387277	548
BAOMC47-908935	908935	531	FEL17368		516-521	PH200-T020	582048	548
CEF500317	777128	551	FEL17410	3853412	506-525	PH200-T020	582155	548
CEF500506	911826	560-567	FEL17420	856034	509	PH200-T023	986280	548
CEF500514K	3854127	560-567	FEL17420	3852468	526-527	PH200-T023	3853945	548
CEF500521K	912374	568	FEL17420		510-511	PH300-0007	985964	547
CEF500527K	914036	560-567	FEL17440	3852472	515-518-529	PH300-0010	985964	547
CEF501003	312781	531	FEL17460	913393	530	PH300-0010	986008	547
CM3855411	3855411	555-571	FEL17460	3852455	528	PH300-0020	988247	547
CM3855411A	3855411	571	FEL17460		507-513-519-520	PH375-0001	1114356	548
CM393023	436745	553-559-571	FEL17468		516-521	PH375-0001	11143589	548
CM393023A	436745	571	FEL17725		509-510-512	PH375-0009	3854194	546
CM397768	397768	571	FEL17740		515-518	PH375-0012	345419	548
CM397768A	397768	571	FEL17746		508-519	PH375-0012	383622	548
CM431708	431708	553-559-571	FEL17900	3852693	505	PH375-0012	582708	548
CM431708A	431708	571	FEL17903	3856443	505	PH375-0012	586180	548
CM976669	976669	571	FEL17920	3854300	506	PH375-0027	982187	548
CM976669A	976669	571	FEL17921	3854942	507	PH375-0027	985063	548
CM982438	982438	571	FEL17930	835096	509-510-512	PH375-0030	979774	548
CM983494	983494	559-571	FEL17931	3852687	509-512	PH600-0002	3855991	531
CM983494A	983494	571	FEL17935	856626	515-518	PH600-0004	3858340	531
CM984513	3853818	553-571	FEL17936		515	PH600-0005	985429	531
CM984513A	3853818	571	FEL17937	3853513	515-518	PH600-0005	3853850	531
CM984547	984547	571	FEL17945	835096	508-513-519-520	PH600-0006	982517	531
CM984547A	984547	571	FEL17946	3852687	508-513-520	PH600-0006	3471293	531
CMC		571	FEL17947		516-521	RAC320R-RAC-02	35-802893Q4	534
CMCC		571	FEL17950	3853343	505	RACS3220UL	35-809101	534
CHARS12YC		545	FEL17970		506	RACS3228UL	173233	535
CHARS9YC		545	FEL17971	3852655	506	RACS3228UL	502901	535
CHARV15YC4		545	FEL17980	855729	509-510-511	REC0319662	319662	564
FEL17000	3853336	504-505	FEL17981		509-512	REC0554545	554545	564
FEL17000	908611	504-505	FEL17982	3856138	509-511	REC10-20518	912304	560
FEL17010	3854299	506	FEL17983		509-511	REC10-37612	3853155	528
FEL17020	3853380	508	FEL17985		515-518	REC10-37612	3853326	529
FEL17030	3853380	509	FEL17986		515-518	REC10-79953Q04	307551	561
FEL17030		510	FEL17994		516-521	REC10-861788	10-861788	547
FEL17040		513	FEL17995		507-508-519	REC11-35921	314730	553-559
FEL17042		513	FEL17996		513-520	REC11-8267089	121731	553-559-560
FEL17048		517	FEL17997		507-519	REC11-862903	552938	522-523-524
FEL17049		516	FEL17998		513-520	REC12-191833	311598	562
FEL17060	512-518-520		GDY15386	910414	566-567	REC12-29245	305981	553-559
FEL17068	516-521		GDY17335		566	REC123018	123018	551
FEL17100	504-505		GS38320	3852604	522-523-524-525-526-527-528-529	REC125017	302540	557-561-562-564-564
FEL17102	505		GS38322	984387	526	REC12532	382133	540
FEL17110	506		GS38322	3853860	525-527-528-529	REC126870	126870	553-555-559-570
FEL17115	506		HGE3394	914766	530	REC127084	127084	559-570
FEL17116	506		HGE5470	985470	533	REC13-35048	120177	522-523-524-525-526-527-528-529
FEL17120	508-510-511		HGE6041	986041	530	REC13-35048	309336	526
FEL17124	511		HOT20244-MK		526-527	REC13-39107	306325	526
FEL17125	508-511		HOT20902	912441	526	REC13-39107	306470	522-523-524
FEL17140	514-517		HOT20903	912442	526	REC13430		532
FEL17145	514-517		HOT20921	909863	526-530	REC1347-818619R02	98053	539
FEL17146	513-515-517		HOT20986	3857723	527	REC1347-818619R02	381494	539
FEL17160	507-519		HOT20992-MK		525-527-528-529	REC1347-818619R02	381498	535
FEL17161	507-519		MAR061	3857944	525-527-528-529	REC1347-818619R02	382733	535-539
FEL17165	513-520		MAR499	3847499	525	REC1347-818619R02	772831	535-539
FEL17166	512-520		MAR501	3857723	527	REC1347-818619R02	979821	539
FEL17168	516-521		MP0180-001		547	REC1347-818619R02	980530	535
FEL17169	516-521		MP426422	772846	536-539	REC1347-818619R02	982217	535
FEL17200	504-505		MP426422	3854087	536	REC1347-818619R02	984180	535-539
FEL17201	514		NGKTR5		545	REC1347-9661A3	382821	535-539
FEL17205	514		NGKUR4		545	REC1347-9661A3	383766	535-539
FEL17207	517		OSC0188	980020	524	REC1347-9661A3	384194	535-539
FEL17210	506		PH140-0004	987811	546	REC1396-4656	982537	537
FEL17211	506		PH140-0004	3854190	546	REC1396-4656	982538	537
FEL17214	510		PH140-0004-CCW		547			
FEL17220	508							



REF.	R.O./OEM	PAG	REF.	R.O./OEM	PAG	REF.	R.O./OEM	PAG
REC1396-4656		539	REC301967	301967	564	REC321788	321788	565
REC1396-5238	982539	536-539	REC302537	302537	564	REC321831	321831	565
REC1397-2060	381389	538-539	REC302564	302564	565	REC321895	321895	565
REC1397-2150	983870	534	REC302588	302588	564-565	REC321928	321928	565
REC1397-3327	383087	538	REC303345	303345	565	REC322938	322938	553-559
REC1397-3327	983871	538	REC303347	303347	564	REC322941	322941	553-559
REC1397-3327		539	REC304027	304027	553	REC323338	316499	561
REC1397-3458	380186	537-539	REC304174	304174	560-564	REC323361	323361	553-559
REC1397-5831	508452	536	REC305123	305123	559-564-565-569	REC323362	323362	553-559
REC1397-6367A1	508459	536	REC305242	305242	564-565	REC323664	323664	559-568
REC1398-3089		539	REC305282	305282	557	REC323664	910578	568
REC1463-9382	3853548	544	REC306376	306376	559	REC324369	324369	553-559-565
REC15-401		545	REC307450	307450	564	REC324670	352165	559
REC15-405	503748	545	REC308590	308590	557	REC324766	324766	553-559
REC15-601	503750	545	REC308592	308592	557	REC326649	326649	564
REC15-602	503748	545	REC308627	308627	564-565	REC326649	329380	564
REC15-604		545	REC308768	308768	557	REC326649	909047	564
REC15-801	503752	545	REC308799	308799	561-562	REC326741	326741	564-565
REC15-801	503755	545	REC308825	308825	553-560	REC326849	326849	564-565
REC15-805	503753	545	REC308876	308876	564	REC327031	327031	565
REC15-806	503751	545	REC308928	308924	557	REC327656	327656	553-559
REC15-806	503752	545	REC309731	309731	564	REC327669	327669	553-559
REC15-806	503754	545	REC309731	911871	560-564	REC328096	328096	553-559
REC15-806	503755	545	REC309989	309989	565	REC328694	3852473	557
REC15-811	503752	545	REC31-35990A1	983891	551	REC328702	306358	559
REC15-811	503755	545	REC31-66668A1	3854249	555	REC328825	328825	553-559
REC16-56826	120177	523	REC31-86748A1	3854250	555-561	REC329922	329922	565
REC16-56826	3852093	522-524	REC310414	310414	565	REC329923	329923	565
REC16-70236	314616	524	REC310414	310414	564	REC330137	330137	553-559-565-
REC160084	160084	553-559	REC310584	310584	563-564-565			566-569
REC171177A1	171177A1	543	REC310599	310599	565	REC330265	330265	553-559
REC175266	175266	570	REC310649	310649	559-565	REC330327	330327	565
REC175267	175267	570	REC310870	310870	522-523-524	REC331103	331103	565
REC18-8553		526	REC311121	311121	522-523-524	REC331188	322501	560-564
REC183247	3850853	554	REC313080	313080	561-562	REC331880	331880	553-559
REC195141		543	REC313163	313163	557	REC331999	331999	553-559
REC21-20553	306405	525-527-528-529	REC313164	313164	557	REC332261	332261	565
REC21533394	987438	537	REC313167	313167	557	REC332583	305739	564
REC21533394	987440	537	REC313175	313175	551-557-564-565	REC332583	317178	564
REC21533394	987485	537	REC313176	313176	557	REC332583	332583	564
REC21533394	21533394	537	REC313176	313178	563	REC332583	332584	564
REC21533394		539	REC313194	313193	557	REC332583	911311	560-564
REC22-428611	315713	525-526-527-528-529	REC313194	313194	557	REC333572	333572	564
REC22-67892A05	318544	553-559	REC313195	313195	557	REC333957	333957	553-559
REC22-67892A05	3854539	555	REC313196	313196	557	REC334163	334163	553
REC22-67892A05	318544	557	REC313197	313197	557	REC334163	982422	559
REC22-73379		525-527-528-529	REC313198	313198	557	REC334950	334950	553-565
REC22050		568	REC313199	313199	557	REC336565	336565	553
REC22188		570	REC313200	313200	557	REC33662	380537	541-542
REC24950	35-60494A4	534	REC313202	313202	557	REC33700	380543	541
REC25-25007	321117	564	REC313203	313203	557	REC337061	337061	553-559
REC25-25439	3852565	551-554-564	REC313204	313204	557	REC33708	383587	540
REC25-29845	308624	564	REC313205	313205	557	REC33765T	980152	540
REC25-30224	310327	564-564	REC313206	313206	557	REC337774	337774	559
REC25-30224	910582	557-564-565	REC313244	313244	561	REC337774	912607	568
REC25-30224	310327	557	REC313282	313282	565	REC337778	337778	553-559
REC25-30613	310585	563-564	REC313284	313284	565	REC338484	324701	563
REC25-30613	310967	564	REC313340	31340	564	REC338484	338484	563
REC25-33145	302337	560-561-564-565	REC313340	313340	564	REC338484	910338	559-563
REC25-35027	303360	564-565	REC313353	313353	559-565	REC338518	338518	564
REC25-35029	308621	557-564-565-568	REC313386	313386	563	REC338522	338522	564
REC25-38933	307853	564	REC313446	313446	559	REC339543	339543	564
REC25-38933	322598	564	REC313448	313448	553-559	REC339620	339620	565
REC25-457101	308626	561-564	REC313448	320145	559	REC341280	341280	565
REC25-48171	202893	560-564	REC313715	313715	553-559	REC341281	314218	565
REC25-62702	303191	564	REC313754	313754	564	REC341281	314281	565
REC25-62705	311338	564	REC314167	314167	565	REC34235T	380538	541-542
REC25-70937	911686	551-564-565	REC314491	314491	557-563-564	REC3423A1		542
REC25-80863	307082	564-565	REC314502	314502	559-570	REC342786	332205	565
REC26-419533	313392	565	REC314503	314503	570	REC35-03752		540
REC26-419533	764337	561	REC314503	5008966	559	REC35-06003	778864	535
REC26-69188	321453	565	REC314728	314728	553-559-564	REC35-06004	173834	535
REC26-76868	3286	565	REC314731	314731	553-559-569	REC35-06004	502903	535
REC26-76868	320862	559-565-569	REC314745	314745	553-559	REC35-06007	502900	535
REC26-76868		566	REC315055	315055	522-523-524-536	REC35-49088A2	312456	534
REC26900		543	REC315189	315189	557-561-563	REC35-49088A2	381690	534
REC26901		543	REC315810	315810	559-570	REC35-53336	908034	534
REC26902		543	REC317624	317624	553-559	REC35-8M0061975	174144	534
REC26903		543	REC317624	552940	522-523-524	REC35-8M0061975	502905	534
REC26904		543	REC318372	318372	553-564-565	REC350271	350271	553-559
REC27-33395	3852468	526-527	REC318717	318717	553-564-565	REC3517857	174796	535
REC27-46820	3852472	529	REC318972	318972	565	REC3517857	502904	535
REC27-52546	311068	522-523	REC319085	319085	564-565	REC353076	353076	565
REC27-53354	908079	524	REC32-33189	312781	531	REC3589522	3852561	551-554
REC27-8079821	909758	536	REC32-8M0071007	509282	531	REC3589522	3852562	551-554
REC27-8146801	311069	563	REC320140	320140	564-565	REC375761	375761	557
REC27-8146801	3789161GM	563	REC320570	320570	553-559-570	REC379504	379504	553-559-569
REC27-99757	3853412	525	REC320635	5004941	559	REC379585	379585	557
REC29-47270	318972	565	REC321459	321459	565	REC379628	379628	569
REC30-879194A01	3853807	560	REC321466	321466	565	REC3808228	3852544	560
REC300-00879	3852217	544	REC321467	321467	559-561-562-565	REC382138	382138	548
REC301877	301877	564-565	REC321480	321480	565	REC382165	382165	557
REC301877	326956	565	REC321481	321481	565	REC382212	382212	557
REC301877	326959	564	REC321786	321786	565	REC382407	382407	553-559-569
REC301877	326959	564	REC321787	321787	565	REC382408	382408	553-559-569

REF.	R.O./OEM	PAG	REF.	R.O./OEM	PAG	REF.	R.O./OEM	PAG
REC382883	382883	557-569	REC3857675	3857675	555	REC841994	983073	537
REC3841481	3854127	560-567	REC3858437	3853917	567	REC841994	984487	537
REC384195	384195	553-559	REC3858462	311046	566	REC841994		539
REC3850360	986292	533	REC3858462	3858462	567	REC853868	853858	554
REC3850360	987716	533	REC3858462		566	REC853868	3853858	565
REC3850360	3850360	533	REC3860842	3860842	554	REC854040	3854402	555
REC3850396	3850396	540	REC3862228	502906	534	REC862344A	982240	533
REC385043	385043	553-559	REC3862228	987754	534	REC862344A	985602	533
REC3850495	3850495	523-524	REC3862500	3862500	525-527	REC862344A	985603	533
REC3850594	3850594	550	REC3863090	3863090	555	REC87654	987603	550
REC3850812	3850812	551-554-569	REC3863191	351325	525	REC87660		561-562
REC3850814	3850814	554	REC3863191	913784	530	REC87670		561-562
REC3850852	3850852	554	REC3863191	3863191	526-527-528-529	REC878982	912477	530
REC3850942	3850942	555	REC3863450	3852741	524-525-527-528-529-568	REC879031	983218	563
REC3852045	303067	551-554-564	REC387247	387247	553-559-569	REC89825302	982211	542
REC3852045	329381	564	REC387656	387656	553-559	REC8M0068784	3857532	540
REC3852045	909747	564	REC387817	387817	553-559	REC8M6001217	382125	541
REC3852056	306394	553-555-559-570	REC389039	389039	553-559	REC8M6001217	382136	541
REC3852106	311606	566-567	REC389042	389042	553-559	REC8M6001217		542
REC3852106	311606C	567	REC389455	389455	553-559	REC8M6001219	980893	541
REC3852106	311606	566	REC391-5090	382135	541-542	REC8M6001219	987136	541
REC3852142	306422	522-523-524	REC391-5090Q1		542	REC8M6001219	987894	541
REC3852165	910953	554	REC392-6316		543	REC8M6001219		542
REC3852272	3852272	554-565	REC392-6324Q1		542	REC8M6001249	987895	541-542
REC3852279	3852279	554	REC392-6325Q1		542	REC907761	907761	522-523-524
REC3852315	3852315	555	REC392-6330	985764	543	REC907764	907764	522
REC3852317	3852317	554	REC392-9086T	3853814	541	REC907774	907774	557-563
REC3852350	3852350	555-570	REC392-9766	3853815	541	REC907866	907866	557
REC3852352	911830	560	REC393-9459Q1	380541	540	REC908062	908062	557-561-568
REC3852454	908668	551-554	REC393831	912213	551-554	REC908063	908063	561-568
REC3852455	3852455	528-530	REC395209	395209	553-559-569	REC908064	908064	557-561-568
REC3852464	3852464	566-567	REC39631		554	REC908069	321467	568
REC3852467	3852467	525-526-527	REC398042	398042	559	REC908069	908069	557
REC3852476	909829	531	REC398042	398042	553-555-570	REC908087	908087	557-563
REC3852476	3852476	528-531	REC398042	5008966	570	REC908158	908158	553-559-560
REC3852535	911718	560-564	REC41400		540	REC908194	908194	561-562-564-565
REC3852538	3852538	525-527-529-560-566	REC414153	434153	570	REC908383	908383	561-564-568
REC3852550	3852550	560	REC43436	915918	560	REC908765	908765	536
REC3852560	3852560	554-563	REC43467	434467	553	REC908855	908855	561-565
REC3852568	3852568	551-554	REC436888	436888	553-559-569	REC909048	909048	557-564
REC3852602	912627	528	REC439967	439967	552	REC909121	909121	557-569
REC3852696	3852696	525-527-528-529-568	REC439967	984458	552	REC909123	909123	557
REC3852742	3852742	526-568	REC46335	908700	526	REC909139	909139	557-564-565
REC3852830	3852830	525-527-528-529	REC46335	3853404	525-527-528	REC909140	909140	557-564
REC3852865	3852865	555	REC479956		525-527-529	REC909232	909232	523-524-526
REC3852866	3852866	555	REC5000074	5000074	553-559	REC909316	909316	551-564
REC3852928	305270	564-565	REC5004218	986980	553-568	REC909368	909368	522
REC3852959	3852959	555	REC5004257	5004257	553	REC909371	909371	522-523-524-526
REC3853283	3853283	536	REC5004765	5004765	553	REC909386	909386	557-561
REC3853341		509-510-512	REC5005034	5005034	570	REC909515	909515	561
REC3853397	306435	526	REC502900	502900	535	REC909527	909527	561-562
REC3853434	3853434	528	REC53773		525	REC909604	909604	559
REC3853655	3853655	551-565-566	REC54-815504320	3853786	526	REC909609	909609	526
REC3853799	3853799	532	REC553126	553126	557-567-565	REC909610	909610	526
REC3853801	3853801	542	REC57-34359	912714	567	REC909753	909753	557-563
REC3853854	3853854	549	REC57-36356	910343	567	REC91-805475A1	912273	571
REC3853855	3853855	549	REC57-48122Q	3852504	566-567	REC910236	910236	559
REC3853856	3853856	549	REC57-78200Q1	3852504	566-567	REC910238	910238	557-563-564-565
REC3853857	3853857	549	REC57-96834Q	912714	566	REC910240	910240	557
REC3853934	3853934	555	REC58217	384735	542	REC910310	910310	559
REC3853962	3853962	567	REC59830A7	912212	551-554	REC910389	910389	523
REC3853983		532	REC62092T	982063	533	REC911019	911019	562-565
REC3854001	986642	544	REC75832T	912214	551-569	REC911662	911662	551
REC3854001	3854001	544	REC763891	763891	527	REC911665	911665	551
REC3854002	3854002	544	REC764197	764197	551	REC911668	911668	551
REC3854003	986650	544	REC764799	764799	526-531	REC911678	911678	551
REC3854003	3854003	544	REC767970	305987	565	REC911679	911679	551
REC3854020	986796	538	REC777128	777128	551	REC911680	911680	551
REC3854020	3854020	538	REC777130	379475	563	REC911681	911681	551
REC3854020	3854347	538	REC777130	777130	557	REC911685	911685	551-565-566
REC3854020		539	REC801766		542	REC911693	911693	553
REC3854105	987313	538	REC802385	911702	551	REC911697	911697	551
REC3854105	3854105	538	REC804624R02	981359	535-539	REC911698	911698	551
REC3854105		539	REC804624R02	981428	535-539	REC911699	911699	551
REC3854158	3854158	540	REC804624R02	981564	535-539	REC911700	911700	565
REC3854159	3854159	540	REC804624R02	981705	535-539	REC911700	911700	551-564
REC3854161	3854161	544	REC804624R02	981803	535-539	REC911703	911703	551
REC3854217	3854217	541	REC804624R02	982215	535-539	REC911704	911704	551
REC3854260	3854260	541	REC804624R02	982223	535-539	REC911705	911705	553
REC3854261	3854261	542	REC804624R02	983855	535-539	REC911710	911710	553
REC3854311		542	REC804624R02	985822	535-539	REC911715	911715	553
REC3854331	3854331	541	REC805226A1	3855184	540	REC911750	911750	551
REC3854548	3854548	541	REC806490T	3853787	540	REC911751	911751	551
REC3854549		542	REC823426A1	383918	537	REC911753	911753	551
REC3854595	3854595	555	REC823426A1	384743	537	REC911878	911878	553
REC3855081	311598	553-557-559-561-562	REC823426A1	979659	537	REC911937	911937	551
REC3855081	333572	554-555	REC823426A1	983864	537	REC911962	385367	553
REC3855269	3855269	528	REC823426A1		539	REC911962	911962	559
REC3855271	3855271	528	REC823427A1	982384	536-538-539	REC912127	912127	553-559
REC3855275	3855275	555	REC829207	310953	566	REC912238	912238	551
REC3855276	981650	533	REC829207	909971	566-567	REC912374	912374	526-568
REC3857533	3857533	548	REC834975	980892	542	REC912471	912471	518-530
			REC835702	982336	541	REC912614	912614	551
			REC841243	982342	542	REC913393	913393	518-530
						REC914036	914036	560-567

REF.	R.O./OEM	PAG	REF.	R.O./OEM	PAG	REF.	R.O./OEM	PAG
REC914488	914488	551	REC987739	984036	546	SOL8614-140-21		573
REC915716	915716	569	REC987739	984276	546	SOL8614-143-19	3855481-2	573
REC915719	915719	553	REC987739	984281	546	SOL8614-145-17	3855480-4	573
REC915720	915720	553	REC987739	984730	546	SOL8614-148-15	3855479-6	573
REC915840	915840	551-560-562	REC987739	985902	546	SOL8651-140-24	763312	573
REC915954	915954	553	REC987739	986342	546	SOL8651-145-21	763310	573
REC925093	320303	564-565	REC987739	986837	546	SOL8651-148-16	763304	573
REC925093	925093	554	REC987739	987738	546	SOL8651-148-17	763306	573
REC966382	912509	566-567	REC987739	987739	546	SOL8651-148-19	763308	573
REC967344	313446	553-564-565-569	REC987739	987740	546	SOL8652-140-24	763313	573
REC967344	3852308	554	REC987800	987800	549	SOL8652-145-21	3850322-3	573
REC97258A1	171960	540	REC9D-116		549	SOL8652-148-16	763305	573
REC980183	980183	561	RM21610333	3854086	536-539	SOL8652-148-17	763307	573
REC981195	98195	565	RM3852516	910953	551	SOL8652-148-19	763309	573
REC981195	981195	561-565-568	RM3854874	3854874	525	SOL9411-132-19		574
REC981196	981196	557-565-568	RM3861459	3861459	529	SOL9411-133-17		574
REC981220	981220	557-569	RM3862228	502906	534	SOL9411-135-15		574
REC981268	981268	557-565-568	RM3862228	987754	534	SOL9411-138-13		574
REC981797	981797	562	SHEG9901	3858847	532	SOL9413-125-19		574
REC981799	981799	556	SHEG9903	3851982	532	SOL9413-128-17		574
REC981801	981801	562	SHEG9903	3855079	532	SOL9413-130-15		574
REC981911	981911	534	SHEG9903	3857794	532	SOL9413-133-13		574
REC982209	982209	541	SOL2411-130-19	765184	573	SOL9431-130-19		574
REC982217	381668	535-539	SOL2411-133-17	765183	573	SOL9431-130-21		574
REC982217	979821	539	SOL2411-135-15	765182	573	SOL9431-133-17		574
REC982217	980528	535-539	SOL2411-138-13	765181	573	SOL9431-135-15		574
REC982217	980530	539	SOL2411-140-11	382761	573	SOL9431-138-13		574
REC982217	982217	535-539	SOL2413-125-19	765184	573	SOL9432-130-19		574
REC982217	982219	535-539	SOL2413-128-17	765183	573	SOL9432-133-17		574
REC982217	984180	539	SOL2413-130-15	765182	573	SOL9432-135-15		574
REC982230	982230	534	SOL2413-133-13	765181	573	SOL9432-138-13		574
REC982386	381400	537	SOL2431-130-19	765184	573	SOL9511-143-21		574
REC982386	982386	537	SOL2431-133-17	765183	573	SOL9511-145-19		574
REC982386		539	SOL2431-135-15	765182	573	SOL9511-148-17		574
REC982422	982422	559	SOL2511-142-23	391203	573	SOL9511-150-15		574
REC982946	982946	562	SOL2511-143-21	391202	573	SOL9513-140-21		574
REC982947	982947	562	SOL2511-145-19	765188	573	SOL9513-143-19		574
REC982949	982949	556	SOL2511-148-17	765187	573	SOL9513-145-17		574
REC982997	982997	533	SOL2511-150-15	765186	573	SOL9513-148-15		574
REC983298	983298	557-563	SOL2512-142-23		573	SOL9531-140-19		574
REC983825	983825	551	SOL2512-143-21		573	SOL9531-140-21		574
REC983826	983826	551	SOL2512-145-19		573	SOL9531-140-23		574
REC983877	983877	551	SOL2512-148-17		573	SOL9531-143-17		574
REC983878	983878	551	SOL2512-150-15		573	SOL9531-145-15		574
REC983880	983880	551	SOL2513-140-23	391203	573	SOL9532-140-19		574
REC983892	983892	551	SOL2513-143-19	765188	573	SOL9532-140-21		574
REC983967	983967	551	SOL2513-145-17	765187	573	SOL9532-140-23		574
REC984012	984012	551	SOL2513-148-15	765186	573	SOL9532-143-17		574
REC984264	984264	551	SOL2514-143-19		573	SOL9532-145-15		574
REC984461	984461	550	SOL2514-145-17		573	SOL9571-148-23		574
REC984462	984462	553	SOL2514-148-15		573	SOL9571-150-21		574
REC984491	984491	534	SOL2531-140-19	765188	573	SOL9571-153-19		574
REC984744	984744	551	SOL2531-140-21	391202	573	SOL9571-155-17		574
REC985052	985052	537-539	SOL2531-140-23	391203	573	SOL9571-158-15		574
REC985218	985218	541	SOL2531-143-17	765187	573	SOL9572-148-23		574
REC985612	985612	552	SOL2531-145-15	765186	573	SOL9572-150-21		574
REC986780	986780	538-539	SOL2532-140-19		573	SOL9572-153-19		574
REC986782	986782	538-539	SOL2532-140-21		573	SOL9572-155-17		574
REC986783	986783	538-539	SOL2532-143-17		573	SOL9572-158-15		574
REC986799	986784	537	SOL2532-145-15		573	SOLRBX-100		573
REC986799	986799	537	SOL8611-142-23	763319	573	SOLRBX-101		573
REC986799		539	SOL8611-143-21	763318	573	SOLRBX-105		573
REC986838	986838	553	SOL8611-145-19	3850301-7	573	SOLRBX-106		573
REC986979	986979	553-568	SOL8611-148-17	763316	573	TEN00712	912392	553
REC987315	987315	538-539	SOL8611-150-15	763315	573	TEN00919	3853930	560-571
REC987661	987661	560-568	SOL8612-143-21		573	TEN00920	3854061	571
REC987678	985518	568	SOL8612-145-19	3855481-2	573			
REC987678	986423	568	SOL8612-148-17	3855480-4	573			
REC987678	987604	568	SOL8612-150-15	3855479-6	573			
REC987678	987678	560-568	SOL8613-140-21	763318	573			
REC987739	982749	546	SOL8613-143-19	3850301-7	573			
REC987739	982755	546	SOL8613-145-17	763316	573			
REC987739	982774	546	SOL8613-148-15	763315	573			

# ÍNDICE / TABLE OF CONTENTS / INDICE

## R.O. / OEM --> REF

R.O./OEM	REF	PAG	R.O./OEM	REF	PAG	R.O./OEM	REF	PAG
3286	REC26-76868	565	311130	BAOMC47-311130	531	321831	REC321831	565
17177A1	REC17177A1	543	311338	REC25-62705	564	321895	REC321895	565
31340	REC313340	564	311598	REC12-191833	562	321928	REC321928	565
91170	REC911700	565	311598	REC3855081	553-557-559-561-562	322501	REC331188	560-564
98053	REC1347-818619R02	539	311606	REC3852106	566-567	322598	REC25-38933	564
98195	REC981195	565	311606C	REC3852106	567	322938	REC322938	553-559
120177	REC13-35048	522-523-524-525-526-527-528-529	312148	BA1-312148	531	322941	REC322941	553-559
120177	REC16-56826	523	312456	REC35-49088A2	534	323361	REC323361	553-559
121731	REC11-8267089	553-559-560	312781	CEF501003	531	323362	REC323362	553-559
123018	REC123018	551	312781	REC32-33189	531	323664	REC323664	559-568
126870	REC126870	553-555-559-570	313080	REC313080	561-562	324369	REC324369	553-559-565
127084	REC127084	559-570	313163	REC313163	557	324701	REC338484	563
160084	REC160084	553-559	313164	REC313164	557	324766	REC324766	553-559
171960	REC97258A1	540	313167	REC313167	557	326649	REC326649	564
173233	RACS3228UL	535	313175	REC313175	551-557-564-565	326741	REC326741	564-565
173834	REC35-06004	535	313176	REC313176	557	326849	REC326849	564-565
174144	REC35-8M0061975	534	313178	REC313176	563	326956	REC301877	565
174796	REC3517857	535	313193	REC313194	557	326959	REC301877	564
175266	REC175266	570	313194	REC313194	557	327031	REC327031	565
175267	REC175267	570	313195	REC313195	557	327656	REC327656	553-559
202893	REC25-48171	560-564	313196	REC313196	557	327669	REC327669	553-559
301877	REC301877	564-565	313197	REC313197	557	328096	REC328096	553-559
301967	REC301967	564	313198	REC313198	557	328825	REC328825	553-559
302337	REC25-33145	560-561-564-565	313199	REC313199	557	329380	REC326649	564
302537	REC302537	564	313200	REC313200	557	329381	REC3852045	564
302540	REC125017	557-561-562-564	313202	REC313202	557	329922	REC329922	565
302564	REC302564	565	313203	REC313203	557	329923	REC329923	565
302588	REC302588	564-565	313204	REC313204	557	330137	REC330137	553-559-565-566-569
303067	REC3852045	551-554-564	313205	REC313205	557	330265	REC330265	553-559
303191	REC25-62702	564	313206	REC313206	557	330327	REC330327	565
303345	REC303345	565	313244	REC313244	561	331103	REC331103	565
303347	REC303347	564	313282	REC313282	565	331880	REC331880	553-559
303360	REC25-35027	564-565	313284	REC313284	565	331999	REC331999	553-559
304027	REC304027	553	313340	REC313340	564	332205	REC342786	565
304174	REC304174	560-564	313353	REC313353	559-565	332261	REC332261	565
305123	REC305123	559-564-565-569	313368	REC313368	563	332583	REC332583	564
305242	REC305242	564-565	313392	REC26-419533	565	332584	REC332583	564
305270	REC3852928	564-565	313446	REC313446	559	333572	REC333572	564
305282	REC305282	557	313446	REC967344	553-564-565-569	333572	REC3855081	554-555
305739	REC332583	564	313448	REC313448	553-559	333957	REC333957	553-559
305981	REC12-29245	553-559	313715	REC313715	553-559	334163	REC334163	553
305987	REC767970	565	313754	REC313754	564	334950	REC334950	553-565
306325	REC13-39107	526	314167	REC314167	565	336565	REC336565	553
306358	REC328702	559	314218	REC341281	565	337061	REC337061	553-559
306376	REC306376	559	314281	REC341281	565	337774	REC337774	559
306394	REC3852056	553-555-559-570	314491	REC314491	557-563-564	337778	REC337778	553-559
306405	REC21-20553	525-527-528-529	314502	REC314502	559-570	338484	REC338484	563
306422	REC3852142	522-523-524	314503	REC314503	570	338518	REC338518	564
306435	REC3853397	526	314616	REC16-70236	524	338522	REC338522	564
306470	REC13-39107	522-523-524	314728	REC314728	553-559-564	339543	REC339543	564
307082	REC25-80863	564-565	314730	REC11-35921	553-559	339620	REC339620	565
307450	REC307450	564	314731	REC314731	553-559-569	341280	REC341280	565
307551	REC10-79953Q04	561	314745	REC314745	553-559	345419	PH375-0012	548
307853	REC25-38933	564	314810	BAOMC29-314810	533	350271	REC350271	553-559
308590	REC308590	557	315055	REC315055	522-523-524-536	351325	REC3863191	525
308592	REC308592	557	315189	REC315189	557-561-563	352165	REC324670	559
308621	REC25-35029	557-564-565-568	315713	REC22-428611	525-526-527-528-529	353076	REC353076	565
308624	REC25-29845	564	315810	REC315810	559-570	375761	REC375761	557
308626	REC25-457101	561-564	316499	REC323338	561	379475	REC777130	563
308627	REC308627	564-565	317178	REC332583	564	379504	REC379504	553-559-569
308768	REC308768	557	317624	REC317624	553-559	379585	REC379585	557
308799	REC308799	561-562	318372	REC318372	553-564-565	379628	REC379628	569
308825	REC308825	553-560	318544	REC22-67892A05	553-557-559	380186	REC1397-3458	537-539
308876	REC308876	564	318717	REC318717	553-564-565	380446	BA1-380446	522
308924	REC308928	557	318972	REC29-47270	565	380537	REC33662	541-542
309336	REC13-35048	526	318972	REC318972	565	380538	REC34235T	541-542
309731	REC309731	564	319085	REC319085	564-565	380541	REC393-9459Q1	540
309989	REC309989	565	319662	REC0319662	564	380543	REC33700	541
310141	REC310414	565	320140	REC320140	564-565	381389	REC1397-2060	538-539
310327	REC25-30224	557-564-564	320145	REC313448	559	381400	REC982386	537
310414	REC310414	564	320303	REC925093	564-565	381494	REC1347-818619R02	539
310584	REC310584	563-564-565	320570	REC320570	553-559-570	381498	REC1347-818619R02	535
310585	REC25-30613	563-564	320862	REC26-76868	559-565-569	381668	REC982217	535-539
310599	REC310599	565	321117	REC25-25007	564	381690	REC35-49088A2	534
310649	REC310649	559-565	321453	REC26-69188	565	382125	REC8M6001217	541
310870	REC310870	522-523-524	321459	REC321459	565	382133	REC12532	540
310953	REC829207	566	321466	REC321466	565	382135	REC391-5090	541-542
310967	REC25-30613	564	321467	REC321467	559-561-562-565	382136	REC8M6001217	541
311046	REC3858462	566	321467	REC908069	568	382138	REC382138	548
311068	FEL17300	505-522-523	321480	REC321480	565	382165	REC382165	557
311068	REC27-52546	522-523	321481	REC321481	565	382212	REC382212	557
311069	REC27-8146801	563	321786	REC321786	565	382407	REC382407	553-559-569
311121	REC311121	522-523-524	321787	REC321787	565	382408	REC382408	553-559-569
			321788	REC321788	565	382733	REC1347-818619R02	535-539

R.O./OEM	REF	PAG
382761	SOL2411-140-11	573
382821	REC1347-9661A3	535-539
382883	REC382883	557-569
383087	REC1397-3327	538
383440	ARCVR-404	548
383587	REC33708	540
383622	PH375-0012	548
383766	REC1347-9661A3	535-539
383918	REC823426A1	537
384194	REC1347-9661A3	535-539
384195	REC384195	553-559
384735	REC58217	542
384743	REC823426A1	537
385043	REC385043	553-559
385367	REC911962	553
387247	REC387247	553-559-569
387277	PH200-T020	548
387656	REC387656	553-559
387817	REC387817	553-559
389039	REC389039	553-559
389042	REC389042	553-559
389455	REC389455	553-559
391202	SOL2511-143-21	573
391202	SOL2531-140-21	573
391203	SOL2511-142-23	573
391203	SOL2513-140-23	573
391203	SOL2531-140-23	573
391264	PH200-T014	548
393259	PH200-T014	548
393988	PH200-T014	548
394176	PH200-T014	548
395209	REC395209	553-559-569
397768	CM397768	571
397768	CM397768A	571
398042	REC398042	559
431708	CM431708	553-559-571
431708	CM431708A	571
434153	REC414153	570
434467	REC434467	553
436745	CM393023	553-559-571
436745	CM393023A	571
436888	REC436888	553-559-569
439967	REC439967	552
502900	REC35-06007	535
502900	REC502900	535
502901	RACS3228UL	535
502903	REC35-06004	535
502904	REC3517857	535
502905	REC35-8M0061975	534
502906	REC3862228	534
502906	RM3862228	534
503748	REC15-405	545
503748	REC15-602	545
503750	REC15-601	545
503751	REC15-806	545
503752	REC15-801	545
503752	REC15-806	545
503752	REC15-811	545
503753	REC15-805	545
503754	REC15-806	545
503755	REC15-801	545
503755	REC15-806	545
503755	REC15-811	545
508452	REC1397-5831	536
508459	REC1397-6367A1	536
509282	REC32-8M0071007	531
552938	REC11-862903	522-523-524
552940	REC317624	522-523-524
553126	REC553126	557-567-565
554545	REC0554545	564
582048	PH200-T020	548
582155	PH200-T020	548
582708	PH375-0012	548
586180	PH375-0012	548
763304	SOL8651-148-16	573
763305	SOL8652-148-16	573
763306	SOL8651-148-17	573
763307	SOL8652-148-17	573
763308	SOL8651-148-19	573
763309	SOL8652-148-19	573
763310	SOL8651-145-21	573
763312	SOL8651-140-24	573
763313	SOL8652-140-24	573
763315	SOL8611-150-15	573
763315	SOL8613-148-15	573
763316	SOL8611-148-17	573
763316	SOL8613-145-17	573
763318	SOL8611-143-21	573
763318	SOL8613-140-21	573

R.O./OEM	REF	PAG
763319	SOL8611-142-23	573
763891	REC763891	527
764197	REC764197	551
764337	REC26-419533	561
764799	REC764799	526-531
765181	SOL2411-138-13	573
765181	SOL2413-133-13	573
765182	SOL2411-135-15	573
765182	SOL2413-130-15	573
765182	SOL2431-135-15	573
765183	SOL2411-133-17	573
765183	SOL2413-128-17	573
765183	SOL2431-133-17	573
765184	SOL2411-130-19	573
765184	SOL2413-125-19	573
765184	SOL2431-130-19	573
765186	SOL2511-150-15	573
765186	SOL2513-148-15	573
765186	SOL2531-145-15	573
765187	SOL2511-148-17	573
765187	SOL2513-145-17	573
765187	SOL2531-143-17	573
765188	SOL2511-145-19	573
765188	SOL2513-143-19	573
765188	SOL2531-140-19	573
772831	REC1347-818619R02	535-539
772846	MP426422	536-539
777128	CEF500317	551
777128	REC777128	551
777130	REC777130	557
778864	REC35-06003	535
835096	FEL17930	509-510-512
835096	FEL17945	508-513-519-520
853858	REC853868	554
855729	FEL17980	509-510-511
856034	FEL17420	509
856365	FEL17320	508-510-511-515
856626	FEL17935	515-518
857177	FEL17310	506
907761	REC907761	522-523-524
907764	REC907764	522
907774	REC907774	557-563
907866	REC907866	557
907885	BAOMC1-907885	522-523-524
908014	BAOMC20-908014	523
908034	REC35-53336	534
908062	REC908062	557-561-568
908063	REC908063	561-568
908064	REC908064	557-561-568
908069	REC908069	557
908079	FEL17301	505-524
908079	REC27-53354	524
908087	REC908087	557-563
908158	REC908158	553-559-560
908194	REC908194	561-562-564-565
908216	BAOMC29-908216	533
908383	REC908383	561-564-568
908611	REC17000	304-305
908668	REC3852454	551-554
908700	REC46335	526
908716	BA1-908719	531
908765	REC908765	536
908855	REC908855	561-565
908935	BAOMC47-908935	531
909047	REC326649	564
909048	REC909048	557-564
909121	REC909121	557-569
909123	REC909123	557
909139	REC909139	557-564-565
909140	REC909140	557-564
909232	REC909232	523-524-526
909316	REC909316	551-564
909368	REC909368	522
909371	REC909371	522-523-524-526
909386	REC909386	557-561
909515	REC909515	561
909527	REC909527	561-562
909604	REC909604	559
909609	REC909609	526
909610	REC909610	526
909747	REC3852045	564
909753	REC909753	557-563
909758	REC27-8079821	536
909829	REC3852476	531
909863	HOT20921	526-530
909971	REC829207	566-567
910236	REC910236	559
910238	REC910238	557-563-564-565
910240	REC910240	557

R.O./OEM	REF	PAG
910280	BA1-910280	522
910310	REC910310	559
910338	REC338484	559-563
910343	REC57-36356	567
910384	BA1-910384	523-524
910389	REC910389	523
910414	GDY15386	566-567
910578	REC323664	568
910582	REC25-30224	557-564-565
910953	REC3852165	554
910953	RM3852516	551
911019	REC911019	562-565
911311	REC332583	560-564
911662	REC911662	551
911665	REC911665	551
911668	REC911668	551
911678	REC911678	551
911679	REC911679	551
911680	REC911680	551
911681	REC911681	551
911685	REC911685	551-565-566
911686	REC25-70937	551-564-565
911693	REC911693	553
911697	REC911697	551
911698	REC911698	551
911699	REC911699	551
911700	REC911700	551-564
911702	REC802385	551
911703	REC911703	551
911704	REC911704	551
911705	REC911705	553
911710	REC911710	553
911715	REC911715	553
911718	REC3852535	560-564
911750	REC911750	551
911751	REC911751	551
911753	REC911753	551
911826	CEF500506	560-567
911830	REC3852352	560
911871	REC309731	560-564
911878	REC911878	553
911937	REC911937	551
911962	REC911962	559
912127	REC912127	553-559
912212	REC59830A7	551-554
912213	REC393831	551-554
912214	REC75832T	551-569
912238	REC912238	551
912273	REC91-805475A1	571
912304	REC10-20518	560
912374	CEF500521K	568
912374	REC912374	526-568
912392	TEN00712	553
912441	HOT20902	526
912442	HOT20903	526
912471	REC912471	518-530
912477	REC878982	530
912509	REC966382	567
912607	REC337774	568
912614	REC912614	551
912627	REC3852602	528
912714	REC57-34359	567
912714	REC57-96834Q	566
913393	FEL17460	530
913393	REC913393	518-530
913784	REC3863191	530
914036	CEF500527K	560-567
914036	REC914036	560-567
914488	REC914488	551
914766	HGE3394	530
915716	REC915716	569
915719	REC915719	553
915720	REC915720	553
915840	REC915840	551-560-562
915918	REC43436	560
915954	REC915954	553
925093	REC925093	554
976669	CM976669	571
976669	CM976669A	571
979659	REC823426A1	537
979774	PH375-0030	548
979821	REC1347-818619R02	539
979821	REC982217	539
980020	OSCO188	524
980152	REC33765T	540
980183	REC980183	561
980528	REC982217	535-539
980530	REC1347-818619R02	535
980530	REC982217	539

R.O./OEM	REF	PAG	R.O./OEM	REF	PAG	R.O./OEM	REF	PAG
980536	BAOMC20-980536	522	984462	REC984462	553	3852350	REC3852350	555-570
980617	BAOMC20-980617	530	984487	REC841994	537	3852455	FEL17460	528
980892	REC834975	542	984491	REC984491	534	3852455	REC3852455	528-530
980893	REC8M6001219	541	984536	PH140-0006	546	3852464	REC3852464	566-567
980959	BAOMC-1-980959	530	984547	CM984547	571	3852467	REC3852467	525-526-527
981078	PH140-0013	546	984547	CM984547A	571	3852468	FEL17420	526-527
981195	REC981195	561-565-568	984628	PH140-0005	546	3852468	REC27-33395	526-527
981196	REC981196	557-565-568	984730	REC987739	546	3852472	FEL17440	515-518-529
981220	REC981220	557-569	984744	REC984744	551	3852472	REC27-46820	529
981268	REC981268	557-565-568	984982	PH140-0022-CCW	546	3852473	REC328694	557
981281	BAOMC20-981281	530	985052	REC985052	537-539	3852476	REC3852476	528-531
981288	PH140-0022-CCW	546	985063	PH375-0027	548	3852504	REC57-48122Q	566-567
981289	PH140-0022	546	985218	REC985218	541	3852504	REC57-78200Q1	566-567
981359	REC804624R02	535-539	985237	PH200-T014	548	3852538	REC3852538	525-527-529-560-566
981428	REC804624R02	535-539	985429	PH600-0005	531	3852544	REC3808228	560
981462	BAOMC1-981462	522	985470	HGE5470	533	3852550	REC3852550	560
981564	REC804624R02	535-539	985518	REC987678	568	3852560	REC3852560	554-563
981650	REC3855276	533	985602	REC86234A4	533	3852561	REC3589522	551-554
981705	REC804624R02	535-539	985603	REC86234A4	533	3852562	REC3589524	551-554
981797	REC981797	562	985612	REC985612	552	3852565	REC25-25439	551-554-564
981799	REC981799	556	985764	REC392-6330	543	3852568	REC3852568	551-554
981801	REC981801	562	985822	REC804624R02	535-539	3852604	GS38320	522-523-524-525-526-527-528-529
981803	REC804624R02	535-539	985902	REC987739	546	3852655	FEL17971	506
981911	REC981911	534	985964	PH300-0007	547	3852687	FEL17931	509-512
982058	PH200-T009	548	985964	PH300-0010	547	3852687	FEL17946	508-513-520
982063	REC62092T	533	986008	PH300-0010	547	3852693	FEL17900	505
982121	PH140-0013	546	986041	HGE6041	530	3852696	REC3852696	525-527-528-529-568
982187	PH375-0027	548	986280	PH200-T023	548	3852741	REC3863450	524-525-527-528-529-568
982201	BAOMC29-314810	533	986292	REC3850360	533	3852742	REC3852742	526-568
982202	PH140-0022	546	986342	REC987739	546	3852830	REC3852830	525-527-528-529
982209	REC982209	541	986423	REC987678	568	3852865	REC3852865	555
982211	REC89825302	542	986642	REC3854001	544	3852866	REC3852866	555
982215	REC804624R02	535-539	986650	REC3854003	544	3852959	REC3852959	555
982217	REC1347-818619R02	535	986780	REC986780	538	3853155	REC10-37612	528
982217	REC982217	535-539	986782	REC986782	538	3853256	FEL17304	504-505
982219	REC982217	535-539	986783	REC986783	538	3853283	REC3853283	536
982223	REC804624R02	535-539	986784	REC986799	537	3853326	REC10-37612	529
982230	REC982230	534	986796	REC3854020	538	3853336	FEL17000	504-505
982240	REC86234A4	533	986799	REC986799	537	3853343	FEL17950	505
982336	REC835702	541	986837	REC987739	546	3853380	FEL17020	508
982342	REC841243	542	986838	REC986838	553	3853380	FEL17030	509
982384	REC823427A1	536-538-539	986979	REC986979	553-568	3853404	REC46335	525-527-528
982386	REC982386	537	986980	REC5004218	553-568	3853412	FEL17410	506-525
982422	REC334163	559	987136	REC8M6001219	541	3853412	REC27-99757	525
982422	REC982422	559	987313	REC3854105	538	3853434	REC3853434	528
982438	CM982438	571	987315	REC987315	538-539	3853513	FEL17937	515-518
982517	PH600-0006	531	987438	REC21533394	537	3853548	REC1463-9382	544
982537	REC1396-4656	537	987440	REC21533394	537	3853655	REC3853655	551-565-566
982538	REC1396-4656	537	987485	REC21533394	537	3853786	REC54-815504320	526
982539	REC1396-5238	536-539	987603	REC87654	550	3853787	REC806490T	540
982657	BAOMC1-982657	523	987604	REC987678	568	3853799	REC3853799	532
982706	PH200-T009	548	987661	REC987661	560-568	3853801	REC3853801	542
982749	REC987739	546	987678	REC987678	560-568	3853807	REC30-879194A01	560
982755	REC987739	546	987716	REC3850360	533	3853814	REC392-9086T	541
982774	REC987739	546	987738	REC987739	546	3853815	REC392-9766	541
982946	REC982946	562	987739	REC987739	546	3853818	CM984513	553-571
982947	REC982947	562	987740	REC987739	546	3853818	CM984513A	571
982949	REC982949	556	987754	REC3862228	534	3853850	PH600-0005	531
982997	REC982997	533	987754	RM3862228	534	3853854	REC3853854	549
983019	PH200-T014	548	987800	REC987800	549	3853855	REC3853855	549
983073	REC841994	537	987811	PH140-0004	546	3853856	REC3853856	549
983218	REC879031	563	987894	REC8M6001219	541	3853857	REC3853857	549
983298	REC983298	557-563	987895	REC8M6001249	541	3853858	REC3853868	565
983318	ARC6211	549	988013	PH140-0006	546	3853860	GS38322	525-527-528-529
983494	CM983494	559-571	988217	PH140-0013	546	3853917	REC3858437	567
983494	CM983494A	571	988217	PH140-0020	547	3853930	TEN00919	560-571
983825	REC983825	551	988247	PH300-0020	547	3853934	REC3853934	555
983826	REC983826	551	1114356	PH375-0001	548	3853945	PH200-T023	548
983855	REC804624R02	535-539	3471293	PH600-0006	531	3853962	REC3853962	567
983864	REC823426A1	537	3847499	MAR499	525	3854001	REC3854001	544
983870	REC1397-2150	534	3850360	REC3850360	533	3854002	REC3854002	544
983871	REC1397-3327	538	3850396	REC3850396	540	3854003	REC3854003	544
983877	REC983877	551	3850495	REC3850495	523-524	3854020	REC3854020	538
983878	REC983878	551	3850594	REC3850594	550	3854061	TEN00920	571
983880	REC983880	551	3850799	BAOMC20-910380	523-524	3854086	RM21610333	536-539
983891	REC31-35990A1	551	3850812	REC3850812	551-554-569	3854087	MP426422	536
983892	REC983892	551	3850814	REC3850814	554	3854105	REC3854105	538
983967	REC983967	551	3850852	REC3850852	554	3854127	CEF500514K	560-567
984012	REC984012	551	3850853	REC183247	554	3854127	REC3841481	560-567
984036	REC987739	546	3850942	REC3850942	555	3854158	REC3854158	540
984054	BAOMC1-984054	524	3851982	SHEG9903	532	3854159	REC3854159	540
984180	REC1347-818619R02	535-539	3852093	REC16-56826	522-524	3854161	REC3854161	544
984180	REC982217	539	3852217	REC300-00879	544	3854190	PH140-0004	546
984264	REC984264	551	3852272	REC3852272	554-565	3854194	PH375-0009	546
984276	REC987739	546	3852279	REC3852279	554	3854217	REC3854217	541
984281	REC987739	546	3852308	REC967344	554	3854249	REC31-66668A1	555
984387	GS38322	526	3852315	REC3852315	555	3854250	REC31-86748A1	555-561
984458	REC439967	552	3852317	REC3852317	554			
984461	REC984461	550	3852347	BAOMC1-3852347	528			

R.O./OEM	REF	PAG	R.O./OEM	REF	PAG	R.O./OEM	REF	PAG
3854254	BAOMC29-910303	533	3857533	REC3857533	548	21533394	REC21533394	537
3854260	REC3854260	541	3857675	REC3857675	555	10-861788	REC10-861788	547
3854261	REC3854261	542	3857723	HOT20986	527	35-60494A4	REC24950	534
3854299	FEL17010	506	3857723	MAR501	527	35-802893Q4	RAC320R-RAC-02	534
3854300	FEL17920	506	3857794	SHEG9903	532	35-809101	RACS3220UL	534
3854331	REC3854331	541	3857944	MAR061	525-527-528-529	3789161GM	REC27-8146801	563
3854347	REC3854020	538	3858340	PH600-0004	531	3850301-7	SOL8611-145-19	573
3854402	REC854040	555	3858462	REC3858462	567	3850301-7	SOL8613-143-19	573
3854539	REC22-67892A05	555	3858847	SHEG9901	532	3850322-3	SOL8652-145-21	573
3854548	REC3854548	541	3860566	PH140-0015	547	3855479-6	SOL8612-150-15	573
3854595	REC3854595	555	3860566	PH140-0017-D	547	3855479-6	SOL8614-148-15	573
3854874	RM3854874	525	3860842	REC3860842	554	3855480-4	SOL8612-148-17	573
3854942	FEL17921	507	3861459	RM3861459	529	3855480-4	SOL8614-145-17	573
3855079	SHEG9903	532	3862500	REC3862500	525-527	3855481-2	SOL8612-145-19	573
3855184	REC805226A1	540	3863090	REC3863090	555	3855481-2	SOL8614-143-19	573
3855269	REC3855269	528	3863191	REC3863191	526-527-528-529			
3855271	REC3855271	528	5000074	REC5000074	553-559			
3855275	REC3855275	555	5004257	REC5004257	553			
3855411	CM3855411	555-571	5004765	REC5004765	553			
3855411	CM3855411A	571	5004941	REC320635	559			
3855991	PH600-0002	531	5005034	REC5005034	570			
3856138	FEL17982	509-511	5008966	REC314503	559			
3856443	FEL17903	505	5008966	REC314503	559			
3857532	REC8M0068784	540	5008966	REC398042	553-555-570			
			11143589	PH375-0001	548			

## ÍNDICE

<b>PARTES DE MOTOR</b>	<b>PÁG</b>
• JUNTAS CULATA Y KITS	584
• JUNTAS TAPA BALANCINES	589
• JUNTAS TURBO	591
• JUNTAS CARTER	590
• JUNTAS TAPAS	591
• JUNTAS TAPA RESPIRADERO	591
• JUNTAS TAPA VARILLA DE ACEITE	592
• JUNTAS TAPA RETÉN TRASERO Y DELANTERO	592
<b>RETENES DE CIGÜEÑAL</b>	<b>595</b>
<b>PISTONES</b>	<b>596</b>
• KITS AROS	596
• KITS COJINETES DE BANCADA	597
• KITS COJINETES DE BIELA	598
• KITS COJINETES AXIALES	599
<b>VALVULAS</b>	<b>599</b>
• RETENES	599
• VÁLVULAS ADMISIÓN & ESCAPE	600
<b>SISTEMA DE ESCAPE Y ADMISIÓN</b>	
• JUNTAS COLECTOR ADMISIÓN	589
• JUNTAS TAPA ADMISIÓN	589
• JUNTAS COLECTOR ESCAPE	590
• JUNTAS TAPA ESCAPE	590
• JUNTAS CODOS ESCAPE	590
• CODOS ESCAPE	601
<b>SISTEMA DE REFRIGERACIÓN</b>	
• BOMBA ASPIRACIÓN AGUA MARINA	602
• IMPULSORES	592
• JUNTAS BOMBA	603
• CORREA BOMBAS	606
<b>TERMOSTATOS</b>	<b>603</b>
• JUNTAS	604
<b>SISTEMA ALIMENTACIÓN Y FILTRACIÓN</b>	
• FILTROS COMBUSTIBLE	604
• FILTROS ACEITE	605
• JUNTAS BOMBA COMBUSTIBLE	591
• JUNTAS TAPA BOMBA	591
• JUNTAS BOMBA ACEITE	606
• FILTROS DE AIRE	607
<b>TURBOS</b>	<b>608</b>
<b>SISTEMA ELÉCTRICO</b>	
• SENSORES TEMPERATURA	607
• MOTORES DE ARRANQUE	610
• ALTERNADORES	611
• CORREAS	611
<b>ARANDELAS</b>	
• COBRE	593
• ANILLOS DE GOMA	594
• ARANDELAS SELLO	594
<b>SOPORTES ELÁSTICOS</b>	<b>612</b>
<b>ÁNODOS</b>	<b>612</b>
• JUNTAS TAPA ÁNODO	591
<b>HÉLICES</b>	<b>614</b>
<b>GUÍA DE MANTENIMIENTO</b>	<b>616</b>
<b>ÍNDICE REF</b>	<b>621</b>

## TABLE OF CONTENTS

<b>ENGINE PARTS</b>	<b>PAG</b>
• CYLINDER HEAD GASKETS & KITS	584
• VALVE COVER GASKET	589
• TURBO GASKET	591
• OIL PAN GASKETS	590
• COVER GASKETS	591
• BREATHER COVER GASKET	591
• COVER GASKET OIL DIPSTICK	592
• REAR & FRONT SEAL COVER GASKET	592
<b>CRANKSHAFT SEALS</b>	<b>595</b>
<b>PISTONS</b>	<b>596</b>
• PISTONS RINGS SET	596
• MAIN BEARING KITS	597
• CONNETTING ROD BEARING KITS	599
• AXIAL BEARING KITS	599
<b>VALVES</b>	<b>599</b>
• VALVE STEM SEALS	599
• INTAKE & EXHAUST VALVES	600
<b>EXHAUST &amp; INTAKE SYSTEM</b>	
• INTAKE MANIFOLD GASKET	589
• INTAKE COVER GASKET	589
• EXHAUST MANIFOLDS GASKETS	590
• EXHAUST COVER GASKET	590
• EXHAUST ELBOWS GASKETS	590
• EXHAUST ELBOWS	601
<b>COOLING SYSTEM</b>	
• RAW MARINE WATER PUMPS	602
• IMPELLERS	592
• PUMP GASKET	603
• PUMP BELT	606
<b>THERMOSTAT</b>	<b>603</b>
• GASKETS	604
<b>FUEL &amp; FILTRATION SYSTEM</b>	
• FUEL FILTERS	604
• OIL FILTER	605
• FUEL PUMP GASKET	591
• PUMP COVER GASKET	591
• OIL PUMP GASKETS	606
• AIR FILTERS	607
<b>TURBO</b>	<b>608</b>
<b>ELECTRIC SYSTEM</b>	
• TEMPERATURE SENSOR	607
• STARTER	610
• ALTERNATORS	611
• BELTS	611
<b>WASHERS</b>	
• COPPER WASHERS	593
• RUBBER O-RING	594
• SEAL WASHER	594
<b>FLEXIBLE ENGINE MOUNTS</b>	<b>612</b>
<b>ANODES</b>	<b>612</b>
• COVER GASKET ANODE	591
<b>PROPELLERS</b>	<b>614</b>
<b>MAINTENANCE GUIDE</b>	<b>616</b>
<b>REF TABLE</b>	<b>621</b>

## INDICE

<b>PARTI DEL MOTORE</b>	<b>PAG</b>
• GUARNIZIONE TESTATA E KIT	584
• GUARNIZIONE COPERCHIO PUNTERIE	589
• GUARNIZIONE TURBINE	591
• GUARNIZIONE CARTER	590
• GUARNIZIONE COPERCHIO	591
• GUARNIZIONE COPERCHIO SFIATATOIO	591
• GUARNIZIONE COPERCHIO ASTA DI LIVELLO DELL'OLIO	592
• GUARNIZIONE COPERCHIO PARAOLIO POSTERIORE E ANTERIORE	592
<b>PARAOLIO ALBERO MOTORE</b>	<b>595</b>
<b>PISTONI</b>	<b>596</b>
• KIT FASCE PISTONI	596
• KIT BRONZINE DI BANCO	597
• KIT BRONZINE DI BIELLA	598
• KIT BRONZINE ASSIALE	599
<b>VALVOLE</b>	<b>599</b>
• PARAOLIO VALVOLE	599
• PARAOLIO ASPIRAZIONE E SCARICO	600
<b>SISTEMA SCARICO E ASPIRAZIONE</b>	
• GUARNIZIONE COLLETTORE ASPIRAZIONE	589
• GUARNIZIONE COPERCHIO ASPIRAZIONE	589
• GUARNIZIONE COLLETTORE SCARICO	590
• GUARNIZIONE COPERCHIO SCARICO	590
• GUARNIZIONE GOMITI SCARICO	590
• GOMITI SCARICO	601
<b>SISTEMA DI REFFREDDAMENTO</b>	
• GUIDA POMPA DI RICIRCOLO	602
• GIRANTI	592
• GUARNIZIONE POMPA	603
• CINGHIE POMPA	606
<b>TERMOSTATI</b>	<b>603</b>
• GUARNIZIONE	604
<b>SISTEMA ALIMENTAZIONE E FILTRAZIONE</b>	
• FILTRI COMBUSTIBILE	604
• FILTRI OLIO	605
• GUARNIZIONE POMPA COMBUSTIBILE	591
• GUARNIZIONE COPERCHIO POMPA	591
• GUARNIZIONE POMPE OLIO	606
• FILTRI ARIA	607
<b>TURBINE</b>	<b>608</b>
<b>SISTEMA ELETTRICO</b>	
• SENSORI TEMPERATURA	607
• MOTORINO D'AVVIAMENTO	610
• ALTERNATORE	611
• CINGHIE	611
<b>RONDELLE</b>	
• RONDELLA DI RAME	593
• O-RING IN GOMMA	594
• RONDELLA TENUTA	594
<b>SUPPORTI ELASTICI</b>	<b>612</b>
<b>ANODI</b>	<b>612</b>
• GUARNIZIONE COPECHIO ANODO	591
<b>ELICHE</b>	<b>614</b>
<b>GUIDA DI MANUTENZIONE</b>	<b>616</b>
<b>INDICE REF</b>	<b>621</b>



# JUNTAS MOTORE ENGINE GASKET GUARNIZIONE MOTORI

## JUNTAS CULATA CYLINDER HEAD GASKET GUARNIZIONI TESTATA

Ref.	R.O. OEM	INCLUIDA EN EL KIT INCLUDED IN THE KIT INCLUSO NEL KIT
REC128170-01331	128170-01331	REC728170-92600

**MOTORES / ENGINES / MOTORI**  
1GM, L, Y-C



Ref.	R.O. OEM	INCLUIDA EN EL KIT INCLUDED IN THE KIT INCLUSO NEL KIT
REC128171-01911	128171-01911 128171-01330	REC728171-92601

**MOTORES / ENGINES / MOTORI**  
1GM10



Ref.	R.O. OEM	INCLUIDA EN EL KIT INCLUDED IN THE KIT INCLUSO NEL KIT
REC128271-01911	128271-01911	REC728271-92605

**MOTORES / ENGINES / MOTORI**  
2GM20, F, F-YEU, -YEU  
2GM1P

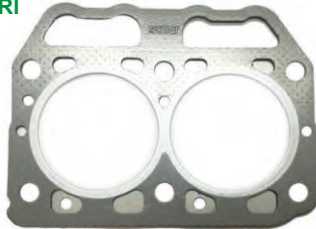

Ref.	R.O. OEM	INCLUIDA EN EL KIT INCLUDED IN THE KIT INCLUSO NEL KIT
REC129002-01331	129002-01331	REC729270-92601

**MOTORES / ENGINES / MOTORI**  
3JH3, E-YEU-E



Ref.	R.O. OEM	INCLUIDA EN EL KIT INCLUDED IN THE KIT INCLUSO NEL KIT
REC129001-01340	129001-01340	REC729271-92600

**MOTORES / ENGINES / MOTORI**  
3JH4E  
3JH5AE, E



Ref.	R.O. OEM	INCLUIDA EN EL KIT INCLUDED IN THE KIT INCLUSO NEL KIT
REC128374-01911	128374-01911	REC728374-92605

**MOTORES / ENGINES / MOTORI**  
3GM30, F, F-YEU

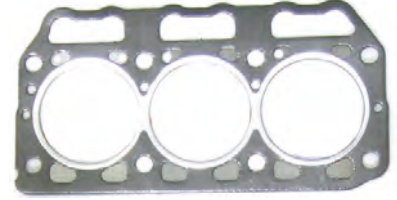

Ref.	R.O. OEM	INCLUIDA EN EL KIT INCLUDED IN THE KIT INCLUSO NEL KIT
REC128671-01330	128671-01330	REC728670-92602

**MOTORES / ENGINES / MOTORI**  
3HM35

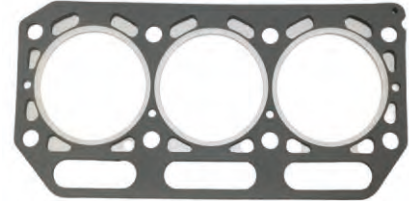

Ref.	R.O. OEM	INCLUIDA EN EL KIT INCLUDED IN THE KIT INCLUSO NEL KIT
REC128370-01332	128370-01331 128370-01332	REC728370-92605

**MOTORES / ENGINES / MOTORI**  
3GM, D, F

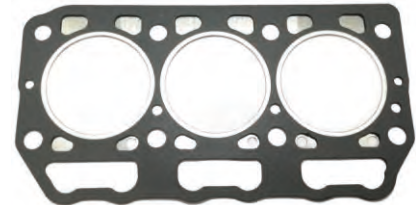

Ref.	R.O. OEM	INCLUIDA EN EL KIT INCLUDED IN THE KIT INCLUSO NEL KIT
REC129171-01330	129171-01330	REC729171-92600

**MOTORES / ENGINES / MOTORI**  
3JH2, 25A, E, L, -TCE

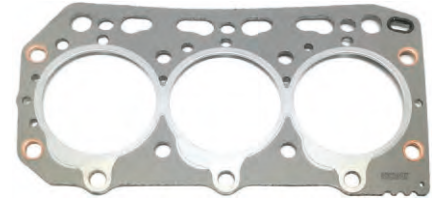

Ref.	R.O. OEM
REC121575-01334	121575-01334
	121575-01333
	121575-01332
	121575-01331

**MOTORES / ENGINES / MOTORI**  
3HM, F

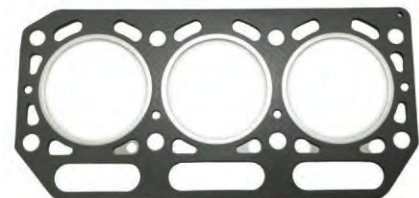

Ref.	R.O. OEM	INCLUIDA EN EL KIT INCLUDED IN THE KIT INCLUSO NEL KIT
REC128625-01342	128625-01342	REC728623-92601

**MOTORES / ENGINES / MOTORI**

6GHA-ET, -ST, -STE  
6GHAK-ST1  
6GHAM-STE  
6GHD-ST

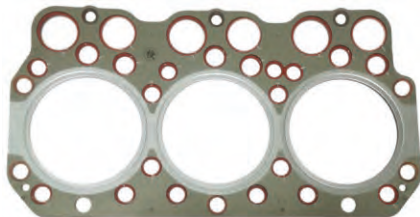

Ref.	R.O. OEM	INCLUIDA EN EL KIT INCLUDED IN THE KIT INCLUSO NEL KIT
REC129408-01330	129408-01330	REC729408-92605

**MOTORES / ENGINES / MOTORI**

4JH3, E, CE, ZA  
4JH3-TCE, -TE



Ref.	R.O. OEM	INCLUIDA EN EL KIT INCLUDED IN THE KIT INCLUSO NEL KIT
REC129407-01340	129407-01340	REC729407-92605

**MOTORES / ENGINES / MOTORI**

4JH4E, AE  
4JH5E

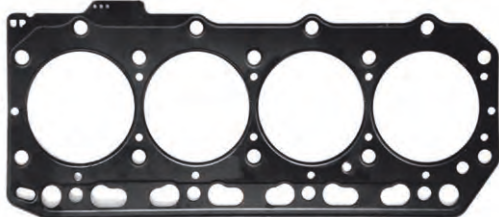

Ref.	R.O. OEM	INCLUIDA EN EL KIT INCLUDED IN THE KIT INCLUSO NEL KIT
REC129573-01351	129573-1351	REC729573-92605

**MOTORES / ENGINES / MOTORI**

4JH2-DTE, E, -HTE, -TE, -UTE

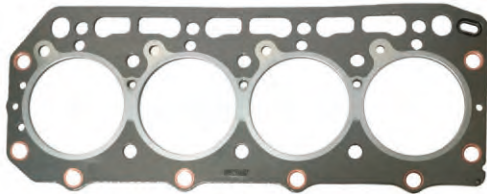

Ref.	R.O. OEM	INCLUIDA EN EL KIT INCLUDED IN THE KIT INCLUSO NEL KIT
REC129693-01331	129693-01331	REC729693-92600

**MOTORES / ENGINES / MOTORI**

4JH3-DTE, -HTE

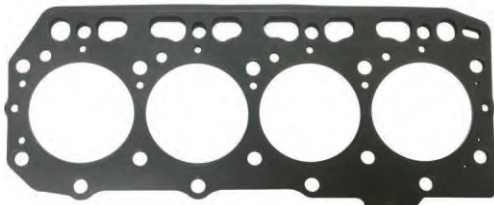

Ref.	R.O. OEM	INCLUIDA EN EL KIT INCLUDED IN THE KIT INCLUSO NEL KIT
REC129553-01350	129553-01350	REC729470-92605

**MOTORES / ENGINES / MOTORI**

4JH-DTE, E, -HTE, -HTZ, -HTZAE, -TE, -TZ

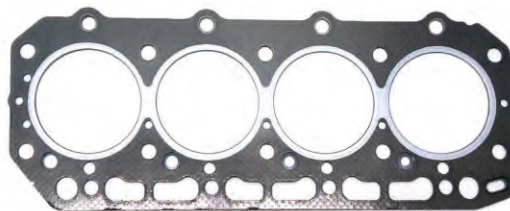

Ref.	R.O. OEM	INCLUIDA EN EL KIT INCLUDED IN THE KIT INCLUSO NEL KIT
REC119174-01340	119174-01340	REC719173-92600 REC719171-92602

**MOTORES / ENGINES / MOTORI**

4LH-TE, -HTE, -DTE, -STE, -HT, -HTZ, -HTZAY, -DTZ, -UT, -UTZAY, -UT2, -ST, -STZAY, -STZ, -WST, -WSTZY  
4LHA-STE, -STP, -STZE, -STZP, -DTE, -DTP, -DTZE, -DTZP, -HTE, -HTP, -HTZE, -HTZP

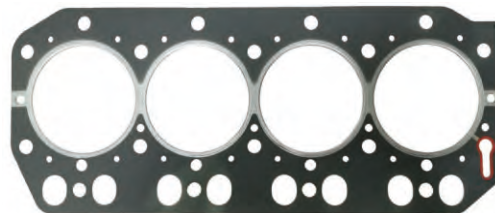

Ref.	R.O. OEM
REC119595-01350	119595-01350

**MOTORES / ENGINES / MOTORI**

6LY2-ST, -STE, -STVY, -STP, -WDT, -WDTZY, -WST  
6LY2A-STE, -STP, -UTP  
6LY2M-WDT, -WST

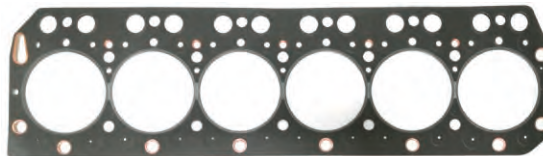

**MARK1**

Ref.	R.O. OEM
REC119771-00401	119771-00401

**MOTORES / ENGINES / MOTORI**

6LP-ST, -STE, -STZE, -STZE1, -STZY, -STZYJ, -WST, -WSTZY



Ref.	R.O. OEM
REC119770-00930	119770-00930

**MOTORES / ENGINES / MOTORI**

6LPA-DTE, -DTP, -DTZE, -DTZP, -DTZEP1  
6LP-DT, -DETE, -DTP, -DTZE, -DTZE1, -DTZEP, -DTZEP1, -DTZY, -WDT, -WDTZY



**MARK3**

Ref.	R.O. OEM
REC119770-00940	119770-00940



**MOTORES / ENGINES / MOTORI**

6LPA-DTE, -DTP, -DTZE, -DTZP, -DTZEP1  
6LP-DT, -DETE, -DTP, -DTZE, -DTZE1, -DTZEP, -DTZEP1, -DTZY, -WDT, -WDTZY



Ref.	R.O. OEM
REC119771-00411	119771-00411



**MOTORES / ENGINES / MOTORI**

6LP-ST, -STE, -STZE, -STZE1, -STZY, -STZYJ, -WST, -WSTZY



**MARK5**

Ref.	R.O. OEM
REC119771-00421	119771-00421



**MOTORES / ENGINES / MOTORI**

6LP-ST, -STE, -STZE, -STZE1, -STZY, -STZYJ, -WST, -WSTZY



Ref.	R.O. OEM
REC119770-00950	119770-00950



**MOTORES / ENGINES / MOTORI**

6LPA-DTE, -DTP, -DTZE, -DTZP, -DTZEP1  
6LP-DT, -DETE, -DTP, -DTZE, -DTZE1, -DTZEP, -DTZEP1, -DTZY, -WDT, -WDTZY



**KIT JUNTAS  
GASKET HEAD SETS  
KIT GUARNIZIONI**

Ref.	R.O. OEM
REC728170-92600	728170-92600

**MOTORES / ENGINES / MOTORI**

1GM  
1GML

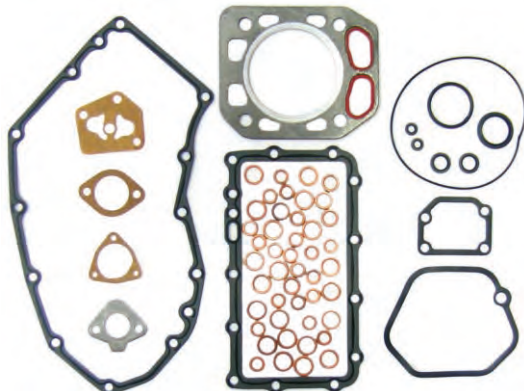

Ref.	R.O. OEM
REC728171-92601	728171-92601

**MOTORES / ENGINES / MOTORI**

1GM10

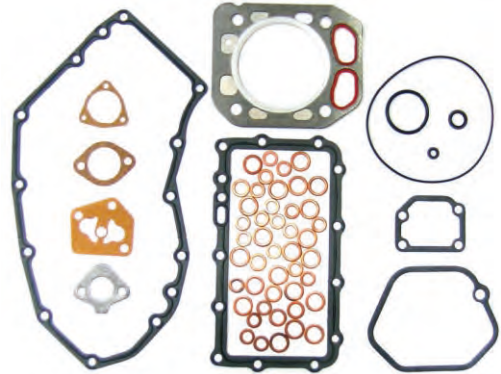

Ref.	R.O. OEM
REC728176-92600	728176-92600



**MOTORES / ENGINES / MOTORI**

1GMY-C

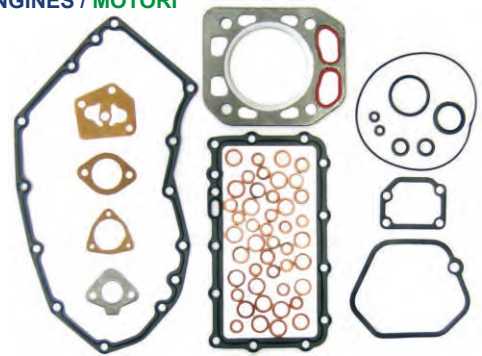

Ref.	R.O. OEM
REC728271-92605	728271-92605

**MOTORES / ENGINES / MOTORI**

2GM20, F

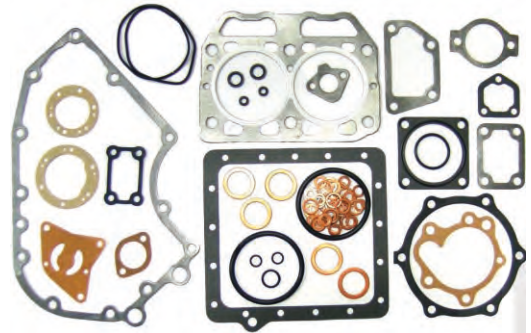

Ref.	R.O. OEM
REC728277-92606	728277-92606



**MOTORES / ENGINES / MOTORI**

2GM20F-YEU, -YEU  
2GM1P

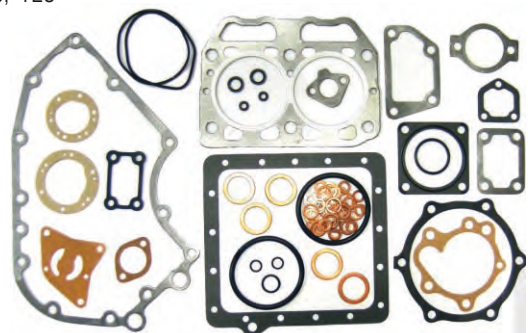

Ref.	R.O. OEM
REC728374-92605	728374-92605

**MOTORES / ENGINES / MOTORI**  
3GM30, F, F-YEU

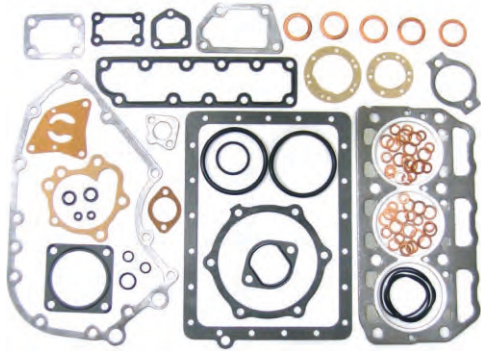

Ref.	R.O. OEM
REC728670-92600	728670-92600

**MOTORES / ENGINES / MOTORI**  
3HM, F

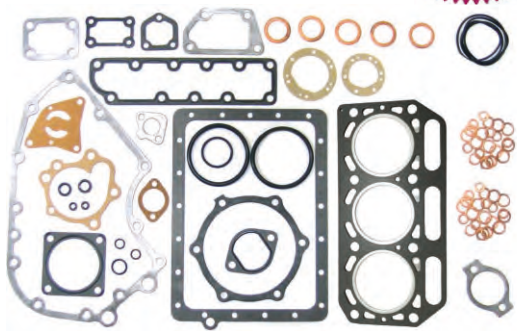

Ref.	R.O. OEM
REC729171-92600	729171-92600

**MOTORES / ENGINES / MOTORI**  
3JH2, E, L, -TCE

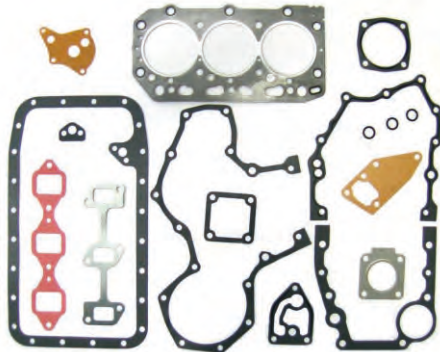

Ref.	R.O. OEM
REC729270-92601	729270-92601

**MOTORES / ENGINES / MOTORI**  
3JH3E-YEU-E

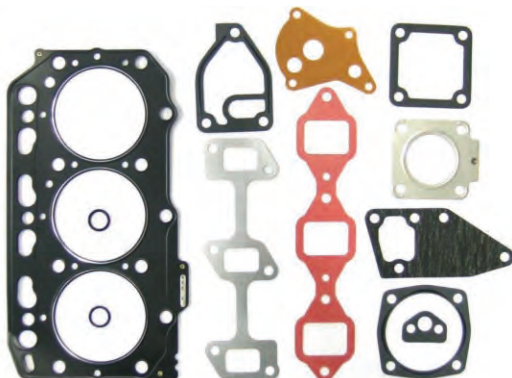

Ref.	R.O. OEM
REC729271-92600	729271-92600

**MOTORES / ENGINES / MOTORI**  
3JH4E  
3JH5

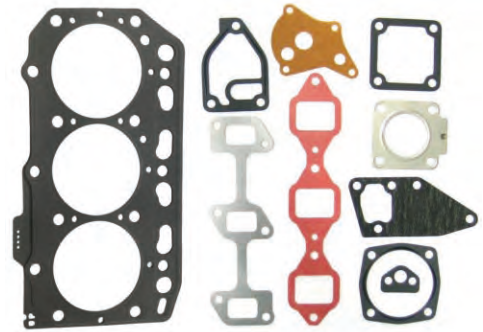

Ref.	R.O. OEM
REC728370-92605	728370-92605 728370-92600

**MOTORES / ENGINES / MOTORI**  
3GM, F, D

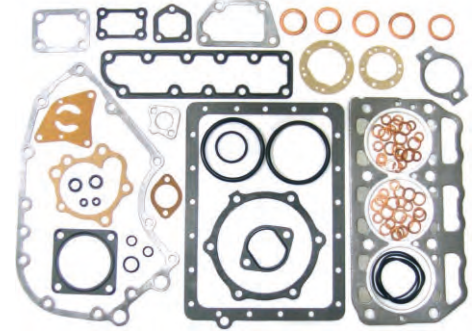

Ref.	R.O. OEM
REC728670-92602	728670-92601 978670-92602

**MOTORES / ENGINES / MOTORI**  
3HM35, C, F

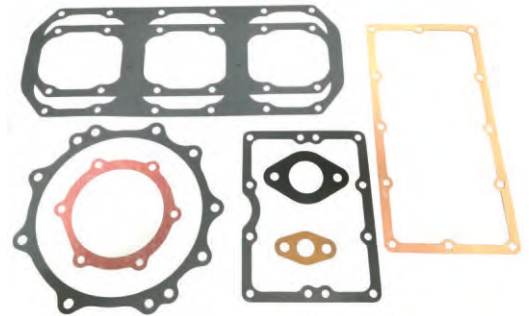

Ref.	R.O. OEM
REC729573-92605	729573-92605

**MOTORES / ENGINES / MOTORI**  
4JH2-DTE, E, -HTE, -TE, -UTE

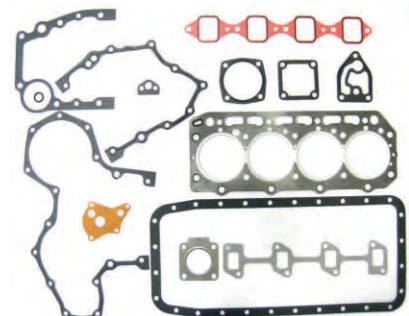

Ref.	R.O. OEM
REC719171-92602	719171-92602

**MOTORES / ENGINES / MOTORI**  
4LH-HTE, -STE, -TE

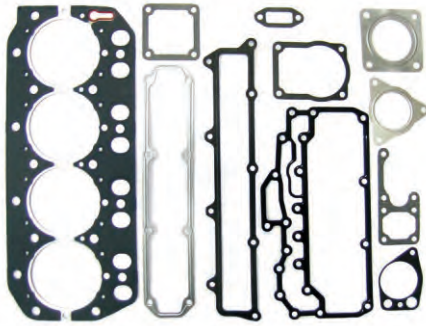

Ref.	R.O. OEM
REC729470-92605	729470-92605

**MOTORES / ENGINES / MOTORI**  
4JH-DTE, E, -HTE, -HTZ, -HTZAE, -TE, -TZ  
4JH4E, AE

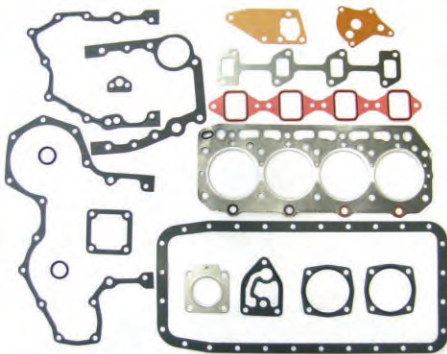

Ref.	R.O. OEM
REC729693-92600	

**MOTORES / ENGINES / MOTORI**  
4JH3-DTE, -HTE, -TE, -TCE

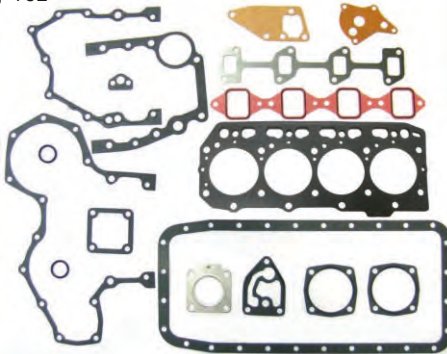

Ref.	R.O. OEM
REC719173-92600	719173-92600

**MOTORES / ENGINES / MOTORI**  
4LHA-DTE, -DTP, -DTZE, -DTZP, -HTE, -HTP,  
-HTZE, -HTZP, -STE, -STP, -STZE, -STZP, -DTE

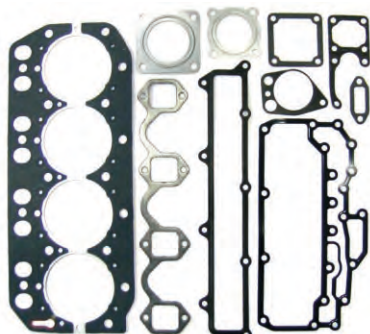

Ref.	R.O. OEM
REC729408-92605	729408-92600 729408-92605

**MOTORES / ENGINES / MOTORI**  
4JH3, CE, 3E, ZA

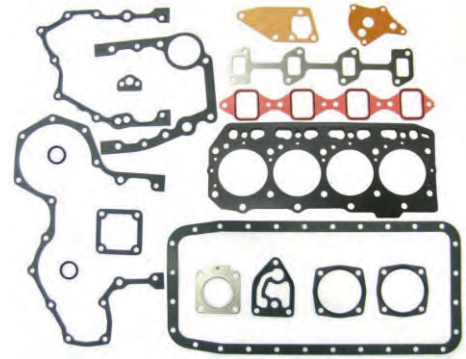

**NEW**

Ref.	R.O. OEM
REC930122	

**MOTORES / ENGINES / MOTORI**  
6LP-DTP, -DTZE, -DTZE1, -DTZP, -DTZP1  
6LPA-DTE, -DTP, -DTZE, -DTZP

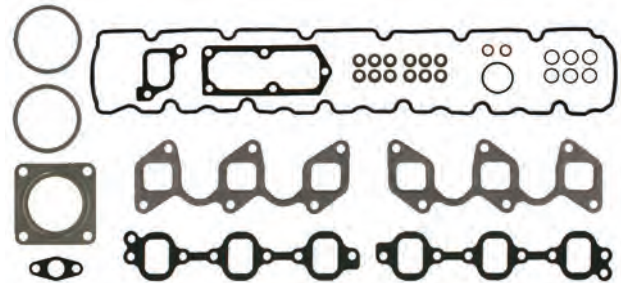

**NEW**

Ref.	R.O. OEM
REC040122	

**MOTORES / ENGINES / MOTORI**  
6LP-STE, -STP, -STZE, -STZE1  
6LPA-STE, -STP, -STZP

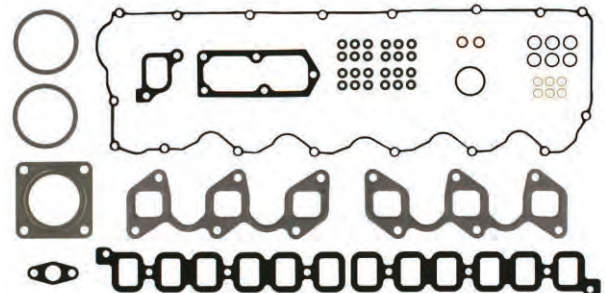

**NEW**

Ref.	R.O. OEM
REC728623-92601	728623-92601

**MOTORES / ENGINES / MOTORI**  
6GHD-ST  
6GHA-ET

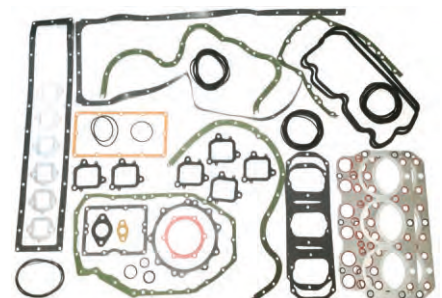

**NEW**

**JUNTAS TAPA BALANCINES**  
**VALVE COVER GASKET**  
**GUARNIZIONE COPERCHIO PUNTERIE**

Ref.	R.O. OEM
REC128170-11310	128170-11310

**MOTORES / ENGINES / MOTORI**  
 1GM, 10, L, Y-C



Ref.	R.O. OEM
REC105225-0240	128270-11310

**MOTORES / ENGINES / MOTORI**  
 2GM  
 2GM20, F, F-YEU, -YEU



Ref.	R.O. OEM
REC121450-11310	121450-11310

**MOTORES / ENGINES / MOTORI**  
 3GM30, F, F-YEU  
 3GMF, 30D



Ref.	R.O. OEM
REC119100-11360	119100-11360

**MOTORES / ENGINES / MOTORI**  
 4LHA-DTE, -DTP, -DTZE, -DTZP, -HTE, -HTP,  
 -HTZE, -HTZP, -STE, -STR, -STZE, -STZP  
 4LH-DTE, -HTE, -STE, -TE



Ref.	R.O. OEM
REC129601-11310	129601-11310

**MOTORES / ENGINES / MOTORI**  
 4JH



Ref.	R.O. OEM
REC119770-00060	119770-00060

**MOTORES / ENGINES / MOTORI**  
 6LP-DTE, -DTP, -DTZE, -DTZE1, -DTZP, -DTZP1  
 6LPA-DTE, -DTP, -DTZE, -DTZP



Ref.	R.O. OEM
REC119593-11380	119593-11380

**MOTORES / ENGINES / MOTORI**  
 6LY-STE, -UTE  
 6LYA-STE, -STP, -UTE, -UTP  
 6LY2-STE, -STP  
 6LY2A-STE, -STP

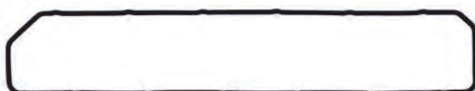

Ref.	R.O. OEM
REC119771-00040	119771-00040

**MOTORES / ENGINES / MOTORI**

6LP-STE, -STP, -STZE, -STZE1  
 6LPA-STE, -STP, -STZP

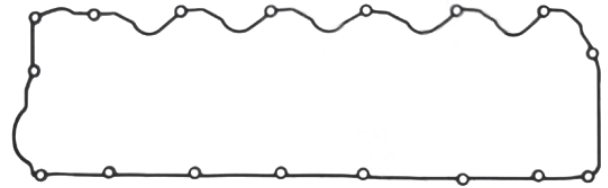

**JUNTAS COLECTOR ADMISIÓN**  
**INTAKE MANIFOLD GASKET**  
**GUARNIZIONE COLLETTORE**  
**ASPIRAZIONE**

Ref.	R.O. OEM
REC129150-12111	129150-12111

**MOTORES / ENGINES / MOTORI**

3JH2, -TCE, E, L  
 3JH25A  
 3JH3, -YEU-E  
 3JH4E  
 3JH5AE, E



Ref.	R.O. OEM
REC119100-12113	119100-12113

**MOTORES / ENGINES / MOTORI**

4LH-DTE, -DTZ, -HT, -HTE, -HTZ, -HTZAY, -ST,  
 -STE, -STZ, -STZAY, -TE, -UT, -UTZ, -UTZAY, -WST,  
 -WSTZY  
 4LHA-DTE, -DTP, -DTZE, -DTZP, -HTE, -HTP,  
 -HTZE, -HTZP, -STE, -STP, -STZE, -STZP



**JUNTAS TAPA ADMISIÓN**  
**INTAKE COVER GASKET**  
**GUARNIZIONE COPERCHIO**  
**ASPIRAZIONE**

Ref.	R.O. OEM
REC129150-77511	129150-77511

**MOTORES / ENGINES / MOTORI**

3JH2, -TCE, E, L  
 3JH25A  
 3JH3, -YEU-E  
 3JH4E  
 3JH5AE, E

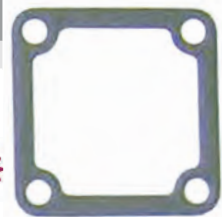

Ref.	R.O. OEM
REC129470-12130	129470-12130

**MOTORES / ENGINES / MOTORI**

4JH, -HTZ, -HTZAE, -TZ  
 4JH2-DTE, E, -HTE, -TE, -UTE  
 4JH3, E, CE, ZA, -TCE, -TE, -DTE, -HTE  
 4JH4E, AE  
 4JH5E



**JUNTAS COLECTOR ESCAPE  
EXHAUST MANIFOLD GASKET  
GUARNIZIONE COLLETTORE SCARICO**

Ref.	R.O. OEM
REC129150-13110	129150-13110

**MOTORES / ENGINES / MOTORI**

3JH2, E, L, -TCE  
3JH25A  
3JH4E  
3JH5AE, E



Ref.	R.O. OEM
REC129550-13110	129550-13110

**MOTORES / ENGINES / MOTORI**

4JH, -DTE, E, -HTE, -HTZ, -HTZAE, -TE, -TZ  
4JH2-DTE, E, -HTE, -TE, -UTE  
4JH3, E, CE, ZA, -TCE, -TE, -DTE, -HTE  
4JH4E, AE  
4JH5E



**JUNTAS TAPA ESCAPE  
EXHAUST COVER GASKET  
GUARNIZIONE COPERCHIO SCARICO**

Ref.	R.O. OEM
REC128370-13181	128370-13181

**MOTORES / ENGINES / MOTORI**

3GM30, F, F-YEU

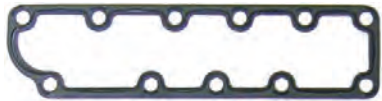

Ref.	R.O. OEM
REC119174-13201	119174-13201

**MOTORES / ENGINES / MOTORI**

4LH-DTE, -DTZ, -HT, -HTE, -HTZ, -ST, -HTZAY,  
-STE, -STZ, -STZAY, -TE, -UT, -UTZ, -UTZAY  
4LHA-DTE, -DTP, -DTZE, -DTZP, -HTE, -HTP,  
-HTZE, -HTZP, -STE, -STP, -STZE



**JUNTAS CODOS ESCAPE  
EXHAUST ELBOWS GASKETS  
GUARNIZIONE GOMITI SCARICO**

Ref.	R.O. OEM
REC129472-18090	129472-18090

**MOTORES / ENGINES / MOTORI**

3JH2, E, L, -TCE  
3JH225A  
3JH3, E-YEU-E  
3JH4E  
3JH5AE, E  
4JH2-DTE, E, -HTE, -TE, -UTE  
4JH, E, -HTE, -HTZ, -HTZAE, -TE, -TZ  
4JH3, E, CE, ZA, -TCE, -TE, -DTE, -HTE  
4JH4AE  
4JH5E



Ref.	R.O. OEM
REC119171-13510	119171-13510

**MOTORES / ENGINES / MOTORI**

4LH-DTE, -DTZ, -HT, -HTE, -HTZ, -ST,  
-HTZAY, -STE, -STZ, -STZAY, -TE, -UT,  
-UTZ, -UTZAY



Ref.	R.O. OEM
REC128170-13201	128170-13201

**MOTORES / ENGINES / MOTORI**

1GM  
2GM



**JUNTAS TURBO  
TURBO GASKET  
GUARNIZIONE TURBINE**

Ref.	R.O. OEM
REC128300-13230	128300-13230

**MOTORES / ENGINES / MOTORI**

4LH-DTE, -DTZ, -HT, -HTE, -HTZ, -ST, -HTZAY, -DTZE1, -DTZY, -ST,  
-STE, -STZ, -STZAY, -TE, -STE, -STZE, -STZE1,  
-UT, -UTZ, -UTZAY -STZY, -STZYJ  
4LHA-DTE, -DTP, -DTZE,  
-DTZP, -HTE, -HTP,  
-HTZE, -HTZP, -STE,  
-STP, -STZE



**JUNTAS CARTER  
OIL PAN GASKET  
GUARNIZIONE CARTER**

Ref.	R.O. OEM
REC128170-01751	128170-01751 128170-01750

**MOTORES / ENGINES / MOTORI**

1GM  
1GM10, -B, C, L, VE



Ref.	R.O. OEM
REC124000-01751	124000-01751 124000-01750

**MOTORES / ENGINES / MOTORI**

2GM20, -YEU, B, C, C-YEU, F, F-YEU, FC-YEU



Ref.	R.O. OEM
REC121000-01751	121000-01751 121000-01750

**MOTORES / ENGINES / MOTORI**

3GM, D, F  
3GM30, , -YEU, B, C, C-YEU, F, F-YEU,  
FC-YEU, FVE, VE



Ref.	R.O. OEM
REC129198-01750	129198-01750

**MOTORES / ENGINES / MOTORI**

3JH2, BE, E, Z



Ref.	R.O. OEM
REC129400-01751	129400-01751 129400-01750

**MOTORES / ENGINES / MOTORI**

4JH, E, -HT, -T, -TE  
4JH2E, -DTE, -HTE, -TE, -UTB, -UTE  
4JH3, ZA, -DTE, -HTE, -TCE, -TE



**NEW**

### JUNTAS TAPA COVER GASKET GUARNIZIONE COPERCHIO

Ref.	R.O. OEM
REC124610-01862	124610-01862 124610-01861

**MOTORES / ENGINES / MOTORI**

4LH-TE, -HTE, -HTZ  
4LHA-HTP, -HTZE,  
-HTZP  
6LY-UT, -ST, -UTZY,  
-STZY, -UTM, -STM,  
-UTE, -STE, -WST,  
-WSTZY, WUT, WUTZY

6LYM-UTE, -STE,  
-UTEHD  
6LY2-ST, -STVY, -STP,  
A-STP, A-UTP, -WDT,  
-WDTZY, -WST  
6LYA-STE, -STP, -UTE



**NEW**

Ref.	R.O. OEM
REC119000-01771	119000-01771

**MOTORES / ENGINES / MOTORI**

4LH-TE, -HTE, -HTZ  
4LHA-HTE, -HTP, -HTZE,  
-HTZP  
6LY-UT, -ST, -UTZY, -STZY,  
-UTM, -STM, -UTE, -STE,  
-WST, -WSTZY, -WUT  
6LYM-UT, -STE  
6LY2-ST, -STVY, -STP,  
-WDT, -WDTZY, -WST

6LY2A-STP, -UTP  
6LYA-STE, -STP, -UTE  
6LYM-UTE, -UTEHD



**NEW**

### JUNTAS TAPA LATERAL SEAL SIDE GUARNIZIONE COPERCHIO LATERALE

Ref.	R.O. OEM
REC121575-01861	121575-01861

**MOTORES / ENGINES / MOTORI**

1GM, 10, L, Y-C  
2GM20, F, -YEU  
2GM1P  
3GM, D, F  
3GM30, F, F-YEU  
3HM, 35, F



**NEW**

### JUNTAS TAPA ÁNODO ZINC COVER GASKET ZINC ANODE GUARNIZIONE COPERCHIO ÁNODO ZINCO

Ref.	R.O. OEM
REC121450-11681	121450-11681 121450-11680

**MOTORES / ENGINES / MOTORI**

2GM20, F, F-YEU, -YEU  
2GM1P  
3GM, D, F, F-YEU



**NEW**

### JUNTAS TAPA VARILLA ACEITE COVER GASKET OIL DIPSTICK GUARNIZIONE COPERCHIO ASTA DI LIVELLO DELL'OLIO

Ref.	R.O. OEM
REC124160-34845	124160-34845 124160-34844

**MOTORES / ENGINES / MOTORI**

3GM, D, F  
3GM30, F, F-YEU



**NEW**

### JUNTAS TAPA RESPIRADERO BREATHER COVER GASKET GUARNIZIONE COPERCHIO SFIATATOIO

Ref.	R.O. OEM
REC128170-03070	128170-03070

**MOTORES / ENGINES / MOTORI**

1GM, L, Y-C  
1GM10



Ref.	R.O. OEM
REC121000-03071	121000-03071 121000-03070

**MOTORES / ENGINES / MOTORI**

2GM1  
2GLMP  
2GM20, F, F-YEU, -YEU  
2GM1P  
3GM30F, F-YEU

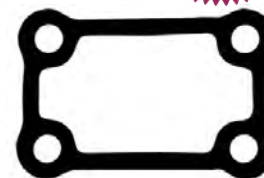

**NEW**

### JUNTAS BOMBA COMBUSTIBLE FUEL PUMP GASKET GUARNIZIONE POMPA COMBUSTIBILE

Ref.	R.O. OEM
REC121520-01851	121520-01851 121520-01850

**MOTORES / ENGINES / MOTORI**

1GM, L, LP, Y-C  
1GM10  
2GM20, F, F-YEU, -YEU  
3GM, D, F  
3GM30, F, F-YEU



**NEW**

### JUNTAS TAPA BOMBA PUMP COVER GASKET GUARNIZIONE COPERCHIO POMPA

Ref.	R.O. OEM
REC124240-01883	124240-01883 124240-01882

**MOTORES / ENGINES / MOTORI**

2GM20, F, F-YEU, -YEU  
2GM1P  
3GM, D, F  
3GM30, F, F-YEU

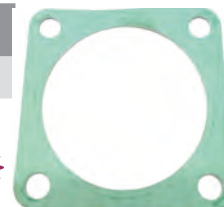

**NEW**

Ref.	R.O. OEM
REC104211-42090	104211-42090

**MOTORES / ENGINES / MOTORI**

1GM, L, Y-C  
2GM20, F, F-YEU  
2GH20-YEU  
2GM1P  
3GM, D, F  
3GM30, F, F-YEU



**NEW**



**JUNTAS TAPA RETÉN TRASERO  
REAR SEAL COVER GASKET  
GUARNIZIONE COPERCHIO  
PARAOLIO POSTERIORE**

Ref.	R.O. OEM
REC105225-02040	105225-02040

**MOTORES / ENGINES / MOTORI**  
2GM20, F, F-YEU, -YEU



Ref.	R.O. OEM
REC129100-01621	129100-01621

**MOTORES / ENGINES / MOTORI**  
3JH25A



Ref.	R.O. OEM
REC105582-82041	105582-82041

**MOTORES / ENGINES / MOTORI**  
1GMY, -C, -EC  
2GMFYE-E  
2GMYE-EC



**JUNTAS TAPA RETÉN DELANTERO  
FRONT SEAL COVER GASKET  
GUARNIZIONE COPERCHIO  
PARAOLIO ANTERIORE**

Ref.	R.O. OEM
REC128170-01510	128170-01510
	128170-01511

**MOTORES / ENGINES / MOTORI**  
1GM, L, Y-C  
1GM10

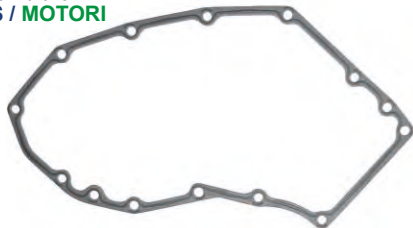

Ref.	R.O. OEM
REC121575-01510	121575-01510
	121575-01511
	121575-01512

**MOTORES / ENGINES / MOTORI**  
1GM, L, Y-C  
1GM10  
2GM20, F, F-YEU, -YEU  
2GMLP  
3GM, D, F  
3GM30, F, F-YEU

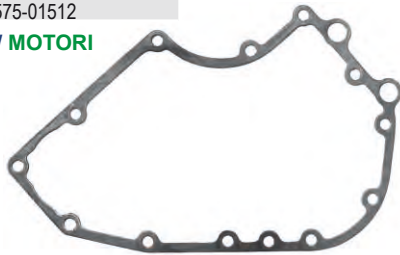

Ref.	R.O. OEM
REC129150-01531	129150-01531

**MOTORES / ENGINES / MOTORI**  
3JH25A



Ref.	R.O. OEM
REC129150-01511	129150-01511

**MOTORES / ENGINES / MOTORI**  
3JH25A

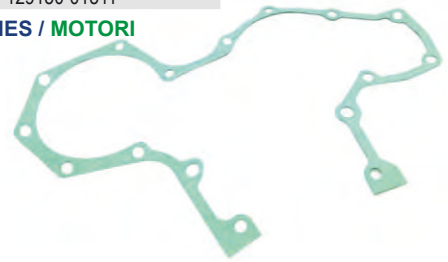

**IMPULSORES  
IMPELLERS  
GIRANTI**

Ref.	R.O. OEM
CEF500113	128176-42080
REC1411-0001	

**MOTORES / ENGINES / MOTORI**  
1GM, L, Y-C  
1GM10



Ref.	R.O. OEM
REC653-0001	128990-42200
	128990-42570

**MOTORES / ENGINES / MOTORI**  
2GM20, F-YEU, -YEU  
3GM30, F-YEU

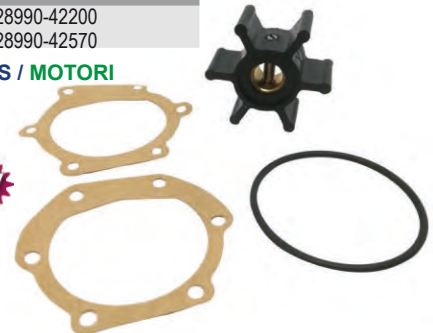

Ref.	R.O. OEM
REC3586494	104211-42070
	104211-42071

**MOTORES / ENGINES / MOTORI**  
2GM, SZK  
3GM30



Ref.	R.O. OEM
REC22779-0001	124223-42091
	124223-42092
	128296-42070
	128620-42200

**MOTORES / ENGINES / MOTORI**  
2GM20F  
3GM30F



Ref.	R.O. OEM
REC3841697	120650-42310
	127610-42200

**MOTORES / ENGINES / MOTORI**  
4LHA-DTE, -DTP, -DTZE, -DTZP, -HTE, -HTP, -HTZE, -HTZP, -STE, -STP, -STZE, -STZP  
4LH-DTE, -DTZ, -HT, -HTE, -HTZ, -HTZAY, -ST, -STE, -STZ, -STZAY, -TE, -UT, -UTZ, -UTZAY  
4CH-DT

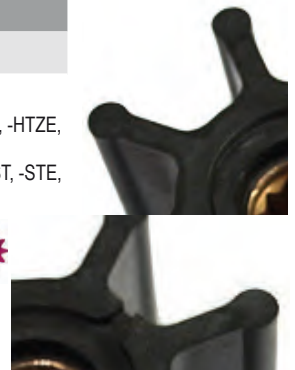

Ref.	R.O. OEM
REC21213660	129470-42530
	129470-42352
	129670-42530
	129670-42531

**MOTORES / ENGINES / MOTORI**

3JH2, E, L, -TCE  
3JH25A  
3JH3, E-YEU-E  
3JHAE  
3JH5AE, E  
4JH2-DTE, E, HTE, -TE, -UTE  
4JH3-HTE, -TE, -DTE  
4JH4E, AE  
4JH5E  
4JHE  
4JH-HTE, -HTZ, -HTZAE, -TE, -TZ



**NEW**

Ref.	R.O. OEM
REC13554-0001	119773-42600
	119773-42601

**MOTORES / ENGINES / MOTORI**

6LPA-DTP, -DTZP, -STP, -STZ  
6LP-DT, -DTE, -DTZE, -DTZY, -ST, -STE, -STZE,  
-STZY, -WDT, -WDTZY



**NEW**

Ref.	R.O. OEM
CEF500162G	119574-42550
	119574-42552

**MOTORES / ENGINES / MOTORI**

6LY2-ST, -STE, -STVY



**NEW**

Ref.	R.O. OEM
REC119574-42550	119574-42550
	119574-42552

**MOTORES / ENGINES / MOTORI**

6LY2-WDT, -WDTZY, -WST  
6LY2A-STE, -STP, -UTP  
6LY2M-WDT, -WST  
6LY3-ETP, -STP, -UTP  
6LYA-STE, -STP, -UTE



**NEW**

Ref.	R.O. OEM
REC128628-42203	128628-42203

**MOTORES / ENGINES / MOTORI**

6GHA-ET, -ST, -STE, K-STI, M-STE  
6GHD-ST

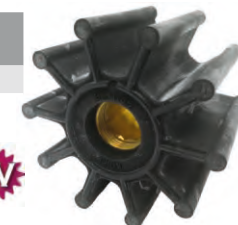

**NEW**

Ref.	R.O. OEM
CEF500161	119593-42200
	119593-42201

**MOTORES / ENGINES / MOTORI**

6LYM-UTEHD  
6LY-ST, -STE, -STM, -STZY, -UT, -UTE, -UTM,  
UTZY, WST, WSTZY, -WUT, -WUTZY, -UTE, -STE



**NEW**

**ARANDELAS  
WASHER  
RONDELLE**

**ARANDELAS DE COBRE  
COPPER WASHER  
RONDELLA DI RAME**

Ref.	R.O. OEM
REC23414-120000	23414-120000
REC23414-100000	23414-100000
REC23414-250000	23414-250000
REC23414-080000	23414-080000

**MOTORES / ENGINES / MOTORI**

1GM, L, Y-C  
1GM10  
2GM20, F  
2GM1P  
2GM20F-YEU, -YEU  
3GM  
3GM30, F, F-YEU  
3HM35  
3JH2, -TCE, E, L  
3JH25A  
3JH3, E-YEU-E  
4JH, -DTE, -HTE, -HTZ, -HTZA, -TE,  
-TZ  
4JH2-DTE, E, -HTE, -TE, -UTE  
4JH3, E, CE, ZA, -TCE, -TE, -DTE,  
-HTE  
4LH-DTE, -STE, -HTE, -TE, -DTZ, -HT,  
-HTZ, -HTZAY, -ST, -STZ, -STZAY, -UT,  
-UTZ, -UTZAY, -WST, -WSTZY  
4LHA-DTE, -DTP, -DTZE, -DTZP, -HTE,  
-HTP, -HTZE, -HTZP, -STE, -STP, AQ-  
STZE, -STZP

**NEW**



REC23414-120000



REC23414-100000



REC23414-250000



REC23414-080000

**ANILLOS DE GOMA  
RUBBER O-RINGS  
O-RING IN GOMMA**

Ref.	R.O. OEM
REC24311-000160	24311-000160
REC24311-000120	24311-000120

**MOTORES / ENGINES / MOTORI**

1GM, L, Y-C  
2GM20, F, F-YEU, -YEU  
2GMLP  
3GM30, F, F-YEU  
3HM35  
3JH25A  
3JH2L  
3JH3E-YEU-E  
3YM20  
3YM27A  
3YM30, AE  
4CH-DT  
4JH3, ZA, CE, -TCE, -TE,  
-DTE, -HTE



Ref.	R.O. OEM
REC24311-000700	24311-000700

**MOTORES / ENGINES / MOTORI**

1GM, L, Y-C  
1GM10  
2GM20, F, F-YEU, -YEU  
2GMLP  
3GM30, F, F-YEU  
3HM35  
4LHA-DTE, -DTP, -DTZE,  
-DTZP, -HTE, -HTP,  
-HTZE, -STE, -HTZP,  
-STP, -STZE, -STZP



Ref.	R.O. OEM
REC24311-000100	24311-000100

**MOTORES / ENGINES / MOTORI**

1GM, L, Y-C  
1GM10  
2GM20, F, F-YEU, -YEU  
2GMLP  
3GM30, F, F-YEU  
3HM35



Ref.	R.O. OEM
REC24341-000240	24341-000240

**MOTORES / ENGINES / MOTORI**

1GM 4JH  
2GM 4JL  
3JH 6LY



Ref.	R.O. OEM
REC24321-000350	24321-000350
	24325-000350

**MOTORES / ENGINES / MOTORI**

2GM20F-YEU, -YEU  
2GMLP  
3GM30, F, F-YEU  
3HYM35  
4CH-DT  
6GHA-ET, -ST, -STE  
6HGAK-ST1  
6GHAM-STE  
6GSD-ST



Ref.	R.O. OEM
REC105225-02020	105225-02020

**MOTORES / ENGINES / MOTORI**

2GM20F-YEU, -YEU  
2GMLP  
3GM30, F, F-YEU



Ref.	R.O. OEM
REC121850-51960	121850-51960

**MOTORES / ENGINES / MOTORI**

3JH  
4JH



Ref.	R.O. OEM
REC129470-01550	129470-01550

**MOTORES / ENGINES / MOTORI**

3JH2, -TCE, E  
3JH3  
4JH, -DTE, -HTE, -HTZ, -HTZAE, -TE, -TZ  
4JH2-DTE, -HTE, -TE, -UTE  
4JH3, ZA, CE, -TCE, -TE, -DTE, -HTE



Ref.	R.O. OEM
REC24311-000320	24311-000320

**MOTORES / ENGINES / MOTORI**

3JH  
4JH



Ref.	R.O. OEM
REC119609-32040	119609-32040

**MOTORES / ENGINES / MOTORI**

3JH25A  
3JH40  
3JH4E  
4JH



**ARANDELAS SELLO  
SEAL WASHER  
RONDELLA TENUTA**

Ref.	R.O. OEM
REC22190-060002	22190-060002
REC22190-080002	22190-080002

**MOTORES / ENGINES / MOTORI**

1GM10  
1GML, Y-C  
2GM20, F, F-YEU, -YEU  
2GMLP  
3GM30, F, F-YEU  
3JH25A  
4JH-HTZAE, -TZ  
4JH3, E, CE, ZA, -TCE, -TE  
SERIE 4LHA



Ref.	R.O. OEM
REC22190-120002	22190-120002



**MOTORES / ENGINES / MOTORI**

- 1GM10
- 1GML, Y-C
- 2GM20, F, F-YEU, -YEU
- 2GMLP
- 3GM30, F, F-YEU
- 3HM35
- 3JH3, E-YEU-E
- 3YM20
- 3YM27A
- 3YM30, AE
- 4JH-HTZAE
- 4JH3, ZA, E, -TCE, -TE, CE, -DTE, -HTE
- 4JHA3CE

- 4JH-HTE, -TE
- 4JH4E, AE
- 4JH5E
- SERIE 4LHA
- SERIE 4LH
- SERIE 6LP
- SERIE 6LPA



Ref.	R.O. OEM
REC43400-500390	43400-500390



**MOTORES / ENGINES / MOTORI**

- 1GML, Y-C
- 2GM20, F, F-YEU, -YEU
- 2GMLP
- 3GM30, F, F-YEU
- 3JH25A
- 4JH3, E, CE, ZA, -TCE, -TE
- SERIE 4LHA



Ref.	R.O. OEM
REC22190-100002	22190-100002
REC22190-140002	22190-140002



**MOTORES / ENGINES / MOTORI**

- 3JH
- 4JH



REC22190-100002

REC22190-140002

Ref.	R.O. OEM
REC43400-500450	43400-500450



**MOTORES / ENGINES / MOTORI**

- 1GM10
- 1GML, Y-C
- 2GM20, F, F-YEU, -YEU
- 2GMLP
- 3GM30, F, F-YEU
- 3HM35
- 3JH3, E-YEU-E
- 3YM20
- 3YM27A
- 3YM30, AE
- 4JH-HTZAE
- 4JH3, ZA, CE, E, -TCE, -TE, CE, -DTE, -HTE, -HTE, -TE



Ref.	R.O. OEM
REC22190-240002	22190-240002



**MOTORES / ENGINES / MOTORI**

- 1GM10
- 1GML, Y-C
- 6LY3-ETP, -STP, -UTP



**RETENES CIGÜEÑAL  
CRANKSHAFT SEALS  
PARA OLIO ALBERO MOTORE**

**DELANTERO  
FRONT SEAL  
ANTERIORE**

Ref.	R.O. OEM
REC121450-01801	121450-01801



**MOTORES / ENGINES / MOTORI**

- 1GM10
- 1GML, Y-C
- 2GM20, F, F-YEU, -YEU
- 2GMLP
- 2GMSZK
- 3GM30, F, F-YEU
- 3HM, F
- 3HM35



Ref.	R.O. OEM
REC129795-01800	129795-01800



**MOTORES / ENGINES / MOTORI**

- 3JH2, -TCE
- 3JH25A
- 3JH2E, L
- 3JH3, E-YEU-E
- 3JH4E
- 4JH, -DTE, -HTE, -HTZ, -HTZAE, -TE, -TZ
- 4JH2-DTE, -HTE, -TE, -UTE, E
- 4JH3-DTE, -HTEM, -TE
- 4JH4E, E
- 4JH5E



Ref.	R.O. OEM
REC121850-01800	121850-01800



**MOTORES / ENGINES / MOTORI**

- 4LH-DTE, -DTZ, -HT, -HTE, -HTZ, -HTZAY, -ST, -STE, -STZ, -STZAY, -TE, -UT, -UTZ, -UTZAY, -WST, -WSTZY
- 4LHA-DTE, -DTP, -DTZE, -DTZP, -HTE, -HTP, -HTZE, -HTZP, -STE, -STP, -STZE, -STZP
- 6LY-ST, -STE, -STM, -STZY, -UT, -UTE, -UTM, -UTZY
- 6LY3-ETP, -STP, -UTP
- 6LYM-STE, -UTE



Ref.	R.O. OEM
REC122710-01781	122710-01781



**MOTORES / ENGINES / MOTORI**

- 6GHA-ET, -ST, -STE
- 6GHAK-ST1
- 6GHAM-STE
- 6GHD-ST



Ref.	R.O. OEM
REC119595-01800	119595-01800

**MOTORES / ENGINES / MOTORI**  
 6LY-WSY, -WSTZY, -WUT, -WUTZY  
 6LY2-ST, -STE, -STP, -STVY, -WDT, -WDTZY, -WST,  
 A-STE, A-STP, A-UTP, M-WDT, M-WST  
 6LYA-STE, -STP, -UTE  
 6LYM-UTEHD



**NEW**

Ref.	R.O. OEM
REC119770-90090	119770-90090

**MOTORES / ENGINES / MOTORI**  
 6LP-DT, -DTE, -DTZE, -DTZY, -ST, -STE, -STZE,  
 -STZY, -WDT, -WDTZY  
 6LPA-DTP, -DTZP, -STP, -STZ



**NEW**

**TRASERO  
REAR SEAL  
POSTERIORE**

Ref.	R.O. OEM
REC124085-02220	124085-02220

**MOTORES / ENGINES / MOTORI**  
 1GM, L, Y-C  
 1GM10  
 2GM20, -YEU, F, F-YEU  
 2GMLP  
 2GMSZK  
 3GM30, F, F-YEU  
 3HM35



**NEW**

Ref.	R.O. OEM
REC123672-01782	123672-01782

**MOTORES / ENGINES / MOTORI**  
 3JH2, -TCE, E, L  
 3JH25A  
 3JH3, E-YEU-E  
 3JH4E  
 3JH5AE, E  
 3YM20  
 3YM27A  
 3YM30, AE  
 4JH, -DTE, -HTE, -HTZ,  
 -HTZAE, -TE, -TZ  
 4JH2-DTE, -HTE, -TE,  
 -UTE, E  
 4JH3-HTE, -TE  
 4JH4AE, E  
 4JH5E  
 4JHE  
 4CH-DT  
 6CX-ETE, -GT  
 6CXM-ETE



**NEW**

Ref.	R.O. OEM
REC124411-01780	124411-01780

**MOTORES / ENGINES / MOTORI**  
 4LH-DTE, -DTZ, -HT, -HTE, -HTZ, -HTZAY,  
 -ST, -STE, -STZ, -STZAY,  
 -TE, -UT, -UTZ, -UTZAY,  
 -WST, -WSTZY  
 4LHA-DTE, -DTP, -DTZE,  
 -DTZP, -HTE, -HTP,  
 -HTZE, -HTZP, -STE,  
 -STP, -STZE, -STZP  
 6LY-ST, -STE, -STM,  
 -STZY, -UT, -UTE, -UTM,  
 -UTZY, -WST, -WSTZY,  
 -WUT, -WUTZY  
 6LY2-ST, -STE, -STP,  
 -STVY, -WDTZY, -WST  
 6LY2A-STE, -STP, -UTP  
 6LY2M-WDT, -WST  
 6LY3-ETP, -STP, -UTP  
 6LYA-STE, -STP, -UTE  
 6LYM-STE, -UTE,  
 -UTEHD



**NEW**

Ref.	R.O. OEM
REC119770-90290	119770-90290

**MOTORES / ENGINES / MOTORI**  
 6LP-DT, -DTE, -DTZE, -DTZY, -ST, -STE, -STZE,  
 -STZY, -WDT, -WDTZY  
 6LPA-DTP, -DTZP, -STP, -STZ



**NEW**

Ref.	R.O. OEM
REC128610-01650	128610-01650

**MOTORES / ENGINES / MOTORI**  
 6GHA-ET, -ST, -STE  
 6GHAK  
 ST1  
 6GHAM-STE  
 6GHD-ST



**NEW**

**PISTONES  
PISTONS  
PISTONI**

**KITS AROS DE PISTONES  
PISTONS RINGS SETS  
KIT FASCE PISTONI**

Ref.	R.O. OEM
REC721000-22500	721000-22500

**MOTORES / ENGINES / MOTORI**  
 1GM  
 1GML  
 2GMSZK



**NEW**

Ref.	R.O. OEM
REC721575-22500	721575-22500 705311-22500

**MOTORES / ENGINES / MOTORI**  
 1GM10  
 2GM20, -YEU, F, F-YEU  
 2GMLP  
 3GM30, F, F-YEU  
 3HM, F



**NEW**

Ref.	R.O. OEM
REC729120-22500	729120-22500

**MOTORES / ENGINES / MOTORI**  
 3JH2, -TCE, E, L  
 3JH25A



**NEW**

Ref.	R.O. OEM
REC129005-22500	129005-22500

**MOTORES / ENGINES / MOTORI**  
 3JH4E  
 3JH5AE, E  
 4JH4AE, E  
 4JH5E



**NEW**

Ref.	R.O. OEM
REC127610-22501	127610-22501

**MOTORES / ENGINES / MOTORI**  
4CH-DT  
4JH2-HTE, -TE, -UTE



Ref.	R.O. OEM
REC719000-22501	719000-22501

**MOTORES / ENGINES / MOTORI**  
4LH-DTE, -HT, -HTE, -HTZ, -HTZAY, -ST, -STE, -STZ, -STZAY, -TE, -UT, -UTZ, -UTZAY  
4LHA-DTE, -DTP, -DTZE, -DTZP, -HTE, -HTP, -HTZE, -HTZP, -STE, -STP, -STZE, -STZP



Ref.	R.O. OEM
REC129590-22510	129590-22510

**MOTORES / ENGINES / MOTORI**  
4JH, -HTE, -HTZ, -HTZAE, -TE, -TZ, E



Ref.	R.O. OEM
REC119593-22351	119593-22351

**MOTORES / ENGINES / MOTORI**  
4LH-DTZ  
6LY-ST, -STE, -STM, -STZY, -UT, -UTE, UTM, -UTZY, -WST, -WSTZY, -WUT, -WUTZY  
6LYA-STE, -STP, -UTE  
6LYM-STE, -UTE, -UTEHD



Ref.	R.O. OEM
REC119595-22300	119595-22300

**MOTORES / ENGINES / MOTORI**  
6LY2-ST, -STE, -STP, -STVY, -WDT, -WDTZY, -WST  
6LY2A-STE, -STP, -UTP  
6LY2M-WDT, -WST



Ref.	R.O. OEM
REC728633-22500	728633-22500

**MOTORES / ENGINES / MOTORI**  
6GHA-ET, -ST, -STE  
6GHAK-ST1  
6GHAM-STE



Ref.	R.O. OEM
REC704571-22500	704571-22500

**MOTORES / ENGINES / MOTORI**  
YSM12



**KIT DE 6 JUEGOS  
KIT WITH 6 SETS  
KIT DE 6**

Ref.	R.O. OEM
REC119770-00250	119770-00250

**MOTORES / ENGINES / MOTORI**  
6LP-DT, -DTE, -DTZE, -DTZY, -ST, -STE, -STZE, -STZY, -WDT, -WDTZY  
6LPA-DTP, -DTZP, -STP, -STZ



**KITS COJINETES BANCADA  
MAIN BEARING KITS  
KIT BRONZINE DI BANCO**

Ref.	R.O. OEM
REC129150-02800	129150-02800

**MOTORES / ENGINES / MOTORI**  
3JH2, E, L, -TCE  
3JH25A  
4JH2-DTE, E, -HTE, -TE, -UTE,  
4JH-DTE, E, -HTE, -HTZ, -HTZAE,  
-TE, -TZ



Ref.	R.O. OEM
REC719000-02800	719000-02800

**MOTORES / ENGINES / MOTORI**  
4LHA-DTE, -DTP, -DTZE, -DTZP, -HTE, -HTP, -HTZE, -HTZP, -STE, -STP, -STZE, -STZP  
4LH-STE, -DTZ, -HT, -HTE, -HTZ, -HTZAY, -ST, -STE, -STZ, -STZAY, -TE, -UT, -UTZ, -UTZAY, -WST, -WSTZY



Ref.	R.O. OEM
REC719717-02901	719717-02901

**MOTORES / ENGINES / MOTORI**  
3YM20  
3YM27A  
3YM30, AE



Ref.	R.O. OEM
REC129690-02800	129690-02800

**MOTORES / ENGINES / MOTORI**  
3JH3  
4JH3-DFTE, -HTE, -TE



Ref.	R.O. OEM
------	-------------

**MOTORES / ENGINES / MOTORI**  
 6LY2-ST, -STE, -STVY, -STP, -WDT, -WDTZY, -WST  
 6LY2A-STE, -UTP  
 6LY2M-WD, -WST  
 6LY3-ETP, -STP, -UTP  
 6LYA-STE, -STP, -UTE  
 6LYM-UTE  
 6LY-ST, -STE, -STM, -STZY, -UT, -UTE, -UTM,  
 -UTZY, -WST, -WSTZY, -WUT, -WUTZY



**DELANTERO  
FRONT  
ANTERIORE**

Ref.	R.O. OEM
------	-------------

**MOTORES / ENGINES / MOTORI**  
 1GM, L, Y-C 2GMLP  
 1GM10 2GMSZK  
 2GM20, F, F-YEU, -YEU 3GM30, F, 30F-YEU



Ref.	R.O. OEM
------	-------------

**MOTORES / ENGINES / MOTORI**  
 3JH3E-YEU-E  
 3JH4E  
 3JH5AE, E  
 4JH4E, AE  
 4JH5E



**DELANTERO. KIT COMPLETO  
FRONT. FULL KIT  
ANTERIORE. KIT COMPLETO**

Ref.	R.O. OEM
------	-------------

**MOTORES / ENGINES / MOTORI**  
 6LPA-DTP, -DTZP, -STP, -STZ  
 6LP-DT, -DTE, -STZE, -DTZY, -ST, -STE,  
 -STZE, -STZY, -WDT, WDTZY



Ref.	R.O. OEM
------	-------------

**MOTORES / ENGINES / MOTORI**  
 6GHA-ET, -ST, -STE  
 6GHAK-ST1  
 6GHAM-STE  
 6GHD-ST



**CENTRAL  
CENTRAL  
CENTRO**

Ref.	R.O. OEM
------	-------------

**MOTORES / ENGINES / MOTORI**  
 3GM30, F, F-YEU



**TRASERO  
REAR  
POSTRIORE**

Ref.	R.O. OEM
------	-------------

**MOTORES / ENGINES / MOTORI**  
 1GM, L, Y-C  
 1GM10  
 2GM20, F, F-YEU, -YEU  
 2GMLP  
 2GMSZK  
 3GM30, F, 30F-YEU



**KITS COJINETES BIELA  
CONNETING ROD BEARING KITS  
KIT BRONZINE DI BIELLA**

Ref.	R.O. OEM
------	-------------

**MOTORES / ENGINES / MOTORI**  
 6GHA-ET, -ST, -STE  
 6GHAK-ST1  
 6GHAM-STE  
 6GHD-ST



Ref.	R.O. OEM
------	-------------

**MOTORES / ENGINES / MOTORI**  
 3JH2, E, L, -TCE 4JH2-DTE, E, -HTE, -TE,  
 -UTE  
 3JH25A 4JH3-DTE, -HTE, -TE  
 3JH3, E-YEU-E 4JH3-DTE, -HTE, -TE  
 3JH4E 4JH4E, AE  
 3JH5AE, E 4JH5E  
 4JH, -DTE, E, -HTE,  
 -HTZ, -HTZAE, -TE, -TZ



Ref.	R.O. OEM
------	-------------

**MOTORES / ENGINES / MOTORI**  
 1GM, L, Y-C  
 1GM10  
 2GM20, F, F-YEU, -YEU  
 2GMLP  
 2GMSZK  
 3GM30, F, 30F-YEU



Ref.	R.O. OEM
------	-------------

**MOTORES / ENGINES / MOTORI**  
 4LHA-DTE, -DTP, -DTZE, -DTZP, -HTE, -HTP,  
 -HTZE, -HTZP, -STE, -STP, -STZE, -STZP  
 4LH-DTE, -DTZ, -HT, -HTE, -HTZ, HTZAY, -ST,  
 -STE, -STZ, -STZAY, -TE, -UT, -UTZ, -UTZAY, -WST,  
 -WSTZY



Ref.	R.O. OEM
------	-------------

**MOTORES / ENGINES / MOTORI**  
 6LYA-STE, -STP, -UTE  
 6LYM-UTE, -STE, -UTEHD  
 6LY-ST, -STE, -STM, -STZY, -UT, -UTE, -UTM,  
 UTZY, -WST, -WSTZY, -WUT, -WUTZY



Ref.	R.O. OEM
------	-------------

**MOTORES / ENGINES / MOTORI**  
 6LY2-ST, -STE, -STVY, -STP, -WDT, -WDTZY, -WST  
 6LY2A-ST, -STP, -UTP  
 6LY2M-WDT, -WST  
 6LY3-ETP, -STP, -UTP



Ref.	R.O. OEM
------	-------------

REC119770-00260 119770-00260 MARK 2  
 REC119770-01010 119770-01010 MARK 3  
 REC119770-01020 119770-01020 MARK 4  
 REC119770-01030 119770-01030 MARK 5  
 REC119770-01040 119770-01040 MARK 6



**MOTORES / ENGINES / MOTORI**  
 6LPA-DTP, -DTZP, -STP, -STZ  
 6LP-DT, -DTE, -DTZE, -DTZY, -ST, -STE, -STZE,  
 -STZY, -WDT, -WDTZY

**KITS COJINETES AXIALES  
AXIAL BEARING KITS  
KIT BRONZINE ASSIALE**

Ref.	R.O. OEM
REC121450-02160	121450-02160

**MOTORES / ENGINES / MOTORI**  
2GM20, F, F-YEU, -YEU  
2GM1P  
2GMSZK  
3GM30, F, F-YEU



**NEW**

Ref.	R.O. OEM
REC119717-02930	119717-02930

**MOTORES / ENGINES / MOTORI**  
3YM20  
3YM27A  
3YM30, AE



**NEW**

Ref.	R.O. OEM
REC129150-02931	129150-02931

**MOTORES / ENGINES / MOTORI**  
3JH2, E, L, -TCE  
3JH25A  
3JH3, E-YEU-E  
3JH4E  
3JH5AE, E  
4JH, -DTE, E, -HTE,  
-HTZ, -HTZAE, -TE, -TZ  
4JH2-DTE, E, -HTE, -TE,  
-UTE  
4JH3-DTE, -HTE, -TE  
4JH4E, AE  
4JH5E



**NEW**

Ref.	R.O. OEM
REC719000-02930	719000-02930

**MOTORES / ENGINES / MOTORI**

4LHA-DTE, -DSTP, -DTZE,  
-DTZP, -HTE, -HTP, -HTZE,  
-HTZP, -STE, -STP, -STZE,  
-STZP  
4LH-DTE, -DTZ, -HT,  
-HTE, -HTZ, HTZAY, -ST,  
-STE, -STZ, -STZAY, -TE,  
-UT, -UTZ, -UTZAY, -WST,  
-WSTZY



**NEW**

Ref.	R.O. OEM
REC128610-02250	128610-02250

**MOTORES / ENGINES / MOTORI**

6GHA-ET, ST, STE  
6GHAK-ST1  
6GHAM-STE  
6GHD-ST



**NEW**

Ref.	R.O. OEM
REC719593-02590	719593-02590

**MOTORES / ENGINES / MOTORI**

6LY2-ST, -STE, -STP, -STVY,  
-WDT, -WST, -WDTZY  
6LY2A-STE, -STP, -UTP  
6LY2M-WDT  
3-UTP  
6LYA-STE, -STP, -UTE  
6LYM-UTE, -STE, -UTEHD  
6LY-ST, -STE, -STM, -STZY,  
-UT, -UTE, -UTM, UTZY, -WST,  
-WSTZY, -WUT, -WUTZY



**NEW**

Ref.	R.O. OEM
REC119770-00130	119770-00130

**MOTORES / ENGINES / MOTORI**

6LPA-DTP, -DTZP, -STP, -STZ  
6LP-DT, -DTE, -DTZE, -DTZY, -ST, -STE, -STZE,  
-STZY, -WDT, -WDTZY



**NEW**

**VÁLVULAS  
VALVE  
VALVOLE**

**RETENES VÁLVULAS  
VALVE STEM SEALS  
PARAOLIO VALVOLE**

Ref.	R.O. OEM
REC124950-11340	124950-11340

**MOTORES / ENGINES / MOTORI**  
1GM, L, Y-C  
1GM10  
2GM20, F, F-YEU, -YEU  
2GM1P  
2GMSZ  
3GM30, F, F-YEU  
3HM, F  
3HM35



**NEW**

Ref.	R.O. OEM
REC127616-11280	127616-11280

**MOTORES / ENGINES / MOTORI**  
4CH-DT  
6CX-ETE, -GT, M-ETE



**NEW**

Ref.	R.O. OEM
REC121850-11150	121850-11150

**MOTORES / ENGINES / MOTORI**

6GHA-ET, -ST, -STE  
6GHAK-ST1  
6GHAM-STE  
6GHD-ST



**NEW**

Ref.	R.O. OEM
REC119770-91030	119770-91030

**MOTORES / ENGINES / MOTORI**

6LPA-DTP, -DTZP  
6LP-DT, -DTE, -DTZE, -DTZY, -ST, -STE, -STZE,  
-STZY, -WDT, -WDTZY



**NEW**



**RETENES VÁLVULAS ADMISIÓN Y ESCAPE  
INTAKE & EXHAUST SEAL VALVES  
PARAOLIO VALVOLE ASPIRAZIONE E SCARICO**

MOTORES ENGINES MOTORI	ADMISIÓN INTAKE ASPIRAZIONE	R.O. OEM	ESCAPE EXHAUST SCARICO	R.O. OEM
4LHA-HTP, -HTZE, -HTZP, -STE, -STP, -STZE, -STZP 4LH-DTE, -DTZ, -HT, -HTE, -HTZ, -HTZAY, -ST, -STE, -STZ, -STZAY, -TE 6LY2-ST, -STE, -STVY, -STP, -WDT, -WDTZY, -WST 6LY2A-STE, -UTP 6LY2M-WDT, -WST 6LYA-STE, -STP, -UTE 6LYM-UTE, -STE, -UTEHD 6LY-ST, -STE, -STM, -STZY, -UT, -UTE, -UTM, UTZY, -WST, -WSTZY, -WUT, -WUTZY	REC121850-11150	121850-11150	REC119171-11150	119171-11150
3YM20 3YM27A 3YM30, AE	REC119717-11340	119717-11340	REC119717-11350	119717-11350
3JH2, L, E, -TCE 3JH25A 3JH3, E-YEU-E 3JH4E 3JH5AE, E 4JH2-DTE, E, -HTE, -TE, -UTE 4JH3-DTE, -HTE, -TE 4JH4E, AE 4JH5E 4JHE, -HTE, -HTZ, -HTZAE, -TE 6LY3-ETP, -STP, -UTP	REC124460-11340	124460-11340	REC121400-11340	121400-11340



**VÁLVULAS ADMISIÓN Y ESCAPE  
INTAKE & EXHAUST VALVES  
VALVOLE ASPIRAZIONE E SCARICO**

MOTORES ENGINES MOTORI	ADMISIÓN INTAKE ASPIRAZIONE	R.O. OEM	ESCAPE EXHAUST SCARICO	R.O. OEM
4LH-DTE, -DTZ, -HTE, -HTZ, -HTZAY, -ST, -STE, -STZ, -STZAY, -TE, -UT, -UTZ, -UTZAY, -WST, -WSTZY 4LHA-DTE, -DTP, -DTZE, -STZP, -STE, -STP, -STZE, -STZP 6LY-ST, -STE, -STM, -STZY, -UT, -UTE, -UTM, -UTZY, -WST, -WSTZY, -WUT, -WUTZY 6LY2-ST, -STE, -STP, -STVY, -WDT, -WDTZY, -WST, -STE, -STP 6LY2A-UTP 6LY2M-WDT, -WST 6LYA-STE, -STP, UTE 6LYM-STE, -UTE, -UTEHD 6LP-DT, -DTE, -DTZE, -DTZY, -ST, -STE, -STZE, -STZY, -WDT, -WDTZY 6LPA-DT, -DTZP	REC119173-11101	119173-11101	REC119593-11110	119593-11110
4LHA-HTE, -HTP, -HTZE, -HTZP	REC121850-11100	121850-11100		
6GHA-ET, -ST, -STE 6GHAK-ST1 6GHAM-STE 6GHD-ST 3JH5AE, E 4JH4AE 4JH5 3JH2, -TCE, E, L 3JH25A 3JH3 4JH-DTE, -HTE, E 4JH2-DTE, -HTE, -TE, -UTE, E 4JH3-TE 4JH, -HTZ, -HTZAE, -TE, TZ 4JH3-DTE, -HTE	REC128619-11100	128619-11100	REC128619-11110	128619-11110
3HM, F 3HM35	REC129005-11100	129005-11100		
1GM, L, Y-C 1GM10 2GM20, F, F-YEU, -YEU 2GM1P 2GMSZK 3GM30, F, 30F-YEU YSM12 YSB12 YSE12	REC129100-11100	129100-11100	REC129100-11112	129100-11112
4LH-HT, -HTZ, -HTZAY 4LHA-HTE, -HTZE, -HTZP	REC129120-11100	129120-11100	REC129120-11110	129120-11110
	REC104211-11100	104211-11100	REC104211-11110	104211-11110
	REC105225-11100	105225-11100	REC105225-11110	105225-11110
	REC104511-11100	104511-11100		
			REC119171-111100	119171-11110



# CODOS ESCAPE EXHAUST ELBOWS GOMITI SCARICO

Ref.	R.O. OEM
HGE3520	104214-13531
	104214-13521
	104070-13520
	128370-13600
	128990-13520
	127070-13520

## MOTORES / ENGINES / MOTORI

2GM20F, FVE, F-YEU, FC-YEU  
2GMFYE, FL  
3GM, F, FY-E, FYE-E, FLE  
3GMD  
3HM  
3GM30, VE, B, C, -YEU,  
C-YEU, F-YEU, FC-YEU  
3HM35, C  
3YM20  
3YM30, AE



Ref.	R.O. OEM
MAR13552	129792-13552
	129792-13551
	129792-13550
	129671-13551
	129579-13551

## MOTORES / ENGINES / MOTORI

4JH-TZ, -TZA, -HTZ,  
-HTZA, -HTZY, -DTZ,  
-DTZP, -DTZA, -DTZY,  
-TZAE, -HTZAE, -TE,  
-TZ, -TZA, -TZAY, -TZ1,  
-TZ2  
4JH2-TE, -HTE, -DTE,  
-UTE, -ETB, -DTZ  
4JH3-T, -T1, -TZA,  
-TZAY, -HTZ1, -HTZA,  
-HTZY1, -HTZAY



**NEW**

Ref.	R.O. OEM
MAR13200	724770-13200

## MOTORES / ENGINES / MOTORI

2QM  
2QM20



**NEW**

Ref.	R.O. OEM
MAR13561	129470-13561
	129470-13560

## MOTORES / ENGINES / MOTORI

3JH2  
3JH3, E  
3JH5E  
4JH2E, CE, TE, -DTE  
4JH3, E



**NEW**

# CODO ESCAPE INOX STAINLESS STEEL ELBOW GOMITO SCARICO INOX

Ref.	R.O. OEM
SED3092401	119181-13500

## MOTORES / ENGINES / MOTORI

6LPSTE - 6LPDTE (260-315 HP)



Ref.	R.O. OEM
SED3092400	119173-13501

## MOTORES / ENGINES / MOTORI

4LHA-HTE (150 HP), -DTE (190 HP), -STE (230 HP),  
-HTP/-STP/ -ST2P (240 HP)  
6LPA-ST2P (315 HP), -DTP (260 HP)  
6LP-DTE (250 HP), -STE (300 HP)



Ref.	R.O. OEM
SED3092500	119773-13501 119773-13500

## MOTORES / ENGINES / MOTORI

4LH-STE, -YA, -HTP, -DTP, -STP  
4LHA-THE, -DTE, -HTP, -DTP  
6LP-DTE, -STE  
6LPA-STP, -DTP  
6LY2-STE, ST2P  
6LY2A-STEP



# BOMBA ASPIRACIÓN AGUA MARINA RAW MARINE WATER PUMPS POMPE ASPIRAZIONE ACQUA MARINA

Ref.	R.O. OEM	Ref. JOHNSON	IMPULSOR IMPELLER GIRANTE
REC119574-42502	119574-42502	10-13170-01	REC119574-42550
	119574-42501		
	119574-42500		

**MOTORES / ENGINES / MOTORI**  
6LY2-ST, -STVY, -STE, -WST, -WDT, -WDTZY  
6LY2A-STP, -UTP  
6LYA-STP, -STE, -UTE  
6LY2M-WDT, -WST



**NEW**

Ref.	R.O. OEM	Ref. JOHNSON	IMPULSOR IMPELLER GIRANTE
REC129271-42502	129271-42502	10-13328-03	REC21213660
	129271-42501		
	129271-42500		

**MOTORES / ENGINES / MOTORI**

3JH4E  
3JH5A, AE, E  
3JH40  
4JH4AE, E  
4JH5E  
4JH80  
4JH110  
4JH45  
4JH57



**NEW**

Ref.	R.O. OEM	Ref. JOHNSON	IMPULSOR IMPELLER GIRANTE	TUBO TUBE TUBO
REC128397-42500	128397-42500	10-13328-03	REC653-0001	1/2"
	128377-42500			
	121575-42200			
	128990-42510			

**MOTORES / ENGINES / MOTORI**

2GM20-YEU, C-YEU, F-YEU, FC-YEU  
3GM30-YEU, C-YEU, F-YEU, FC-YEU  
2YM15  
3YM20  
3YM30



**NEW**

Ref.	R.O. OEM	IMPULSOR IMPELLER GIRANTE
REC728270-42002	128270-42000	CEF500100GX
	128270-42001	
	128270-42002	

**MOTORES / ENGINES / MOTORI**

2GM, F, L, YE-EC  
2GM20, VE, B, C  
2GMZ  
3GTM  
3GMF, LE  
3HM, F  
3GM30, VE, B, C



**NEW**

Ref.	R.O. OEM	Ref. JOHNSON	IMPULSOR IMPELLER GIRANTE
REC129670-42513	129670-42513	10-13328-04	REC21213660
	129670-42512		
	429670-42511		
	429670-42510		
	129670-42500		
	129670-42501		
	129670-42502		

**MOTORES / ENGINES / MOTORI**

3JH3E, -EPA, CE, E-YEU-E  
3JH4E  
4JH3E, CE, CE1, -TE, -TCE, -HTE, -DTE  
4JH4E, -TE, -HTE, -HTE-1



**NEW**

Ref.	R.O. OEM	Ref. JOHNSON	IMPULSOR IMPELLER GIRANTE
REC119578-42501	119578-42501	10-1286-01	CEF500162G
	119578-42500		

**MOTORES / ENGINES / MOTORI**

6LPY3-ETP  
6LY3-STP, -UTP, -STC, -UTC,  
-ETP-24, -STP-24, -UTP-24,  
-STC-24, -UTC-24



**NEW**

Ref.	R.O. OEM	Ref. JOHNSON	IMPULSOR IMPELLER GIRANTE
REC119773-42502	119773-42502	10-24493-01	REC13554-0001
	119773-42501		
	119773-42650		
	119773-42651		
	119773-42652		

**MOTORES / ENGINES / MOTORI**

6LP-DTE, -STE, -DTE, -DT, -ST, -WDT, -WST  
6LPA-DTE, -DTP, -STE, -STP, -STP2  
Los modelos siguientes necesitan las tomas antiguas:  
The following models need the old water intake:  
I seguenti modelli richiedono i vecchi entrata d'acqua:  
6LP-DTZE, -STZE, -DTZY, -STZY, -STZYJ  
6LPA-STZP, -DTZP1, -STZE, -STZEP1, -STZP2, -STZP3



**NEW**

## CORREA BOMBAS PUMPS BELT CINGHIE POMPA

Ref.	R.O. OEM
REC104511-78780E	104511-78780E

**MOTORES / ENGINES / MOTORI**

2GM20, F, F-YEU, -YEU  
3GM30, F, F-YEU  
3HM, F  
3HM35



**NEW**

**JUNTAS BOMBAS  
PUMPS GASKET  
GUARNIZIONE POMPA**

Ref.	R.O. OEM
REC121000-42052	121000-42052 121000-42051 121000-42050

**MOTORES / ENGINES / MOTORI**

1GM, L, Y-C  
1GM10  
2GM20, F, -YEU,  
F-YEU  
2GMLP

3GM, D, F  
3GM30, F, F-YEU  
3HM, F  
3HM35



Ref.	R.O. OEM
REC129150-01881	129150-01881

**MOTORES / ENGINES / MOTORI**

3JH2, -TCE, E  
3JH25A  
3JH3, E-YEU-E  
3JH4E  
3JH5AE, E

4JH, -DTE, -HTZ,  
-HTZA, -TZ, -TE



**JUNTAS BASE BOMBAS  
PUMPS BASE GASKET  
GUARNIZIONE BASE POMPA**

Ref.	R.O. OEM
REC129486-42050	129486-42050 129150-42020

**MOTORES / ENGINES / MOTORI**

3JH2, -TCE, E, 2L  
3JH25A  
3JH3, E-YEU-E  
3JH4E  
3JH5AE, E  
4JH, -DTE, -HTE, -HTZ, -HTZAE, -TE, -TZ  
4JH2-DTZ, -DTE, -HTE, -TE, E, -UTE  
4JH3-DTZ, ZA, -CE, -TCE, -TE, E, -DTE, -HTE



Ref.	R.O. OEM
REC129150-35111	129150-35111

**MOTORES / ENGINES / MOTORI**

3JH  
4JH

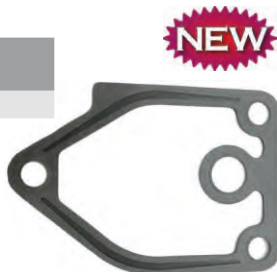

Ref.	R.O. OEM
REC119000-42021	119000-42021

**MOTORES / ENGINES / MOTORI**

4LH-DTE, -HTE, -STE, -TE, -DTZ, -HT, -HTZ, -HTZAY,  
-ST, -STZ, -STZAY, -UT, -UTZ, -UTZAY, -WST, -WSTZY  
4LHA-DTE, -DTZE, -DTZP, -HTE, -HTP, -HTZE, -HTZP,  
-STE, -STP, -STZE, -STZP



**JUNTAS TAPA BOMBAS  
PUMPS COVER GASKET  
GUARNIZIONE COPERCHIO POMPA**

Ref.	R.O. OEM
REC128170-42090	128170-42090

**MOTORES / ENGINES / MOTORI**

1GM  
1GM10, -B, C, L, VE



Ref.	R.O. OEM
REC124223-42110	124223-42110

**MOTORES / ENGINES / MOTORI**

2GMF  
2GM20F, FVE  
3GMF  
3GM30F, FVE

3HM, F  
3HM35, C, F



Ref.	R.O. OEM
REC104211-42090	104211-42090

**MOTORES / ENGINES / MOTORI**

2GM, F  
2GM20, B, C, VE  
3GM  
3GMD  
3GM30, B, C, VE

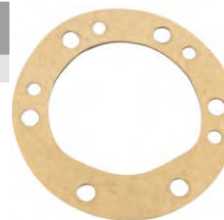

**TERMOSTATO  
THERMOSTAT  
TERMOSTATO**

Ref.	R.O. OEM	42 °C
REC105582-49200	105582-49200 181130-49200 124223-49250	

**MOTORES / ENGINES / MOTORI**

1GM, L, Y-C  
1GM10  
2GM20, -YEU  
2GMSZK

3GM30  
3HM  
3HM35



Ref.	R.O. OEM	71 °C
REC128990-49800	128990-49800	

**MOTORES / ENGINES / MOTORI**

3YM20  
3YM27A  
3YM30



Ref.	R.O. OEM	71 °C
REC121750-49800	121750-49800	

**MOTORES / ENGINES / MOTORI**

2GM20F, F-YEU  
3GM30F, F-YEU  
3HMF  
3YM30AE  
4JH2-DTE



Ref.	R.O. OEM	76,5 °C
REC129470-49801	129470-49801	

**MOTORES / ENGINES / MOTORI**

3JH2M, E, L, -TCE  
3JH25A  
3JH3, E-YEU-E  
3JH4E  
3JH5AE, E  
4JH

4JH2E, -HTE, -TE, -UTE  
4JH3-DTE, -HTE, -TE  
4JH4E, AE  
4JH5E  
4JHE, -HTE, -HTZ,  
-HTZAE, -TE, -TZ



Ref.	R.O. OEM
REC121850-49811	121850-49811 71 °C

**MOTORES / ENGINES / MOTORI**  
4LHA-DTE, -DTP, -DTZE, -DTZP, -HTE, -HTP,  
-HTZE, -HTZP, -STE, -STP, -STZE, -STZP  
4LH-DTE, -DTZ, -HT, -HTE, -HTZ, -HTZAY,  
-STE, -TE, -UT



Ref.	R.O. OEM
REC119773-49550	119773-49550 70 °C

**MOTORES / ENGINES / MOTORI**  
6LPA-DTP, -DTZP, -STP, -STZ



Ref.	R.O. OEM
REC127605-48590	127605-48590 71 °C

**MOTORES / ENGINES / MOTORI**  
6LY2-ST, -STE, -STVY, -WDT, -WDTZY, -WST  
6LY2A-STE, -STP, -UTP  
6LY2M-WDT, -WST  
6LY3-ETP, -STP, -UTP



Ref.	R.O. OEM
REC145640-48410	145640-48410 71 °C

**MOTORES / ENGINES / MOTORI**  
6CX-GT  
6GHA-ET, -ST, -STE  
6GHAK-ST1  
6GHAM-STE  
6GHD-ST  
6KHL-ST



Ref.	R.O. OEM
REC119593-49550	119593-49550 76,5 °C

**MOTORES / ENGINES / MOTORI**  
6LYM-UTE, -STE, -UTEHD  
6LY-ST, -STE, -STM, -STZY, -UT, -UTE, UTM,  
-UTZY, -WST, -WSTZY, -WUT, -WUTZY



Ref.	R.O. OEM
REC165000-69950	165000-69950

**MOTORES / ENGINES / MOTORI**  
4BY  
6BY



**JUNTAS TAPA TERMOSTATO  
THERMOSTAT COVER GASKET  
GUARNIZIONE COPERCHIO  
TERMOSTATI**

Ref.	R.O. OEM
REC104211-49160	104211-49160

**MOTORES / ENGINES / MOTORI**  
1GM, L, Y-C  
1GM10  
2GM20, F, F-YEU, -YEU  
2GM, LP  
3GM, F  
3GM30, F, F-YEU



Ref.	R.O. OEM
REC129350-49541	129350-49541 129350-49540

**MOTORES / ENGINES / MOTORI**  
2GMPL



Ref.	R.O. OEM
REC129795-49551	129795-49551

**MOTORES / ENGINES / MOTORI**  
3JH  
4JH



**JUNTAS CUERPO TERMOSTATO  
THERMOSTAT HOUSING GASKET  
GUARNIZIONE CORPO TERMOSTATI**

Ref.	R.O. OEM
REC121450-44411	121450-44411 121450-44410

**MOTORES / ENGINES / MOTORI**  
1GM, L, Y-C  
1GM10  
2GM20, F, F-YEU, -YEU  
2GM, LP  
3GM, F  
3GM30, F, F-YEU



**FILTROS  
FILTERS  
FILTRI**

**FILTROS COMBUSTIBLE  
FUEL FILTER  
FILTRO BENZINA**

Ref.	R.O. OEM
REC119773-55510	119773-55510

**MOTORES / ENGINES / MOTORI**  
6LPA-DTP, -DTZP, -STP, -STZ  
6LP-DT, -DTE, -DTZE, -DTZY,  
-ST, -STE, -STZE, -STZY, -WDT,  
-WDTZY



Ref.	R.O. OEM
REC127695-55630	127695-55630

**MOTORES / ENGINES / MOTORI**  
6LY2M-WST, -WDT  
6LY-ST, -STZY, -UT, -UTE, -UTM, -UTZY, -WST,  
-WSTZY, -WUT, -WUTZY



Ref.	R.O. OEM
REC121857-55710	121857-55710

**MOTORES / ENGINES / MOTORI**  
4LH-HTE, -TE



Ref.	R.O. OEM
REC129470-55703	129470-55703

**MOTORES / ENGINES / MOTORI**  
3JH25A  
3JH2E, L, -TCE  
3JH3E-YEU-E  
3JHAE  
4JH2-DTE, E, -HTE, -TE  
4JH4E, AE  
4JH5E  
4JH-DTE, E, -HTE, -HTZ, -HTZAE  
6JH2



Ref.	R.O. OEM
REC129574-55711	129574-55711

**MOTORES / ENGINES / MOTORI**  
4JH2-UTE  
4JH3-DTE, -HTE, -TE



Ref.	R.O. OEM
REC41650-501140	41650-501140

**MOTORES / ENGINES / MOTORI**  
6GHA-ET, -ST, -STE  
6GHAK-ST1  
6GHAM-STE  
6GHD-ST



Ref.	R.O. OEM
REC41650-502320	41650-502320

**MOTORES / ENGINES / MOTORI**  
4JH-TZ  
4LHA-DTE, -DTP, -DTZE, -DTZP, -HTE, -HTP,  
-HTZE, -HTZP, -STE, -STP, -STZE, -STZP  
4LH-DTE, -DTZ, -HT, -HTZ, -HTZAY, -ST, -STE,  
-STZ, -STZAY, -UT, -UTZ, -UTZAY



Ref.	R.O. OEM
REC41650-502330	41650-502330

**MOTORES / ENGINES / MOTORI**  
6LY2A-STE, -STP, -UTP  
6LY3-ETP, -STP, -UTP  
6LYA-STE, -STP, -UTE  
6LYM-UTE, -STE, -UTEHD  
6LY-STE, -STM



Ref.	R.O. OEM
REC104500-55710	104500-55710

**MOTORES / ENGINES / MOTORI**  
1GM, L, Y-C  
1GM10  
2GM20, F, F-YEU, -YEU  
2GM1P  
3GM30, F, F-YEU  
3HM, F  
3HM35  
3YM20  
3YM27A  
3YM30, A



Ref.	R.O. OEM
REC127695-55630	127695-55630

**MOTORES / ENGINES / MOTORI**  
6CX-ETE, -GT  
6CXM-ETE



Ref.	R.O. OEM
REC119802-55810	119802-55810

**MOTORES / ENGINES / MOTORI**  
3JH5AE, E



Ref.	R.O. OEM
REC120324-55760	120324-55760

**MOTORES / ENGINES / MOTORI**  
6LY2M-WST, -WDT  
6LY-ST, -STZY, -UT, -UTE, -UTM, -UTZY, -WST,  
-WSTZY, -WUT, -WUTZY, -STM



## FILTROS ACEITE OIL FILTERS FILTRI OLIO

Ref.	R.O. OEM
REC126650-35350	126650-35350

**MOTORES / ENGINES / MOTORI**  
6GHA-ST, -STE  
6GHAK-ST1  
6GHAM-STE  
6GHD-ST



Ref.	R.O. OEM
REC119305-35151	119305-35151

**MOTORES / ENGINES / MOTORI**  
1GM, Y-C  
1GM10  
2GM20, F, F-YEU, -YEU  
2GM1P, SZK  
3GM30, F, F-YEU  
3JH2, E, L, -YCE  
3JH3-YEU-E  
3JH4E  
3JH5, AE  
3YM20  
3YM30



Ref.	R.O. OEM
------	-------------

REC119593-35100 119593-35100



**MOTORES / ENGINES / MOTORI**

6LY3-ETP, -STP, -UTP  
6LYA-STE, -STP, -UTE  
6LYM-UTE, -STE, -UTEHD  
6LY2-ST, -STE, -STVY, -STP, -WDT,  
-WDTZY, -WST  
6LY2A-STE, -STP, -UTP  
6LY2M-WDT, -WST  
6LY-ST, -STE, -STM, -STZY, -UT, -UTE,  
-UTM, -UTZY, -WST, -WSTZY, -WUT, -WUTZY



Ref.	R.O. OEM
------	-------------

REC119770-90620 119770-90620



**MOTORES / ENGINES / MOTORI**

6LPA-DTP, -STZ, -STP  
6LPS-DTZP  
6LP-DT, -DTE, -DTZE, -DTZY,  
-ST, -STE, -STZE, -STZY, -WDT,  
-WDTZY



Ref.	R.O. OEM
------	-------------

REC119593-35400 119593-35400

**MOTORES / ENGINES / MOTORI**

6LY2-ST, -STE, -STVY, -STP,  
-WDT, -WDTZY, -WST  
6LY2A-STE, -STP, -UTP  
6LY2M-WDT, -WST  
6LY-ST, -STE, -STM, -STZY,  
-UT, -UTE, -UTM, -UTZY, -WST,  
-WSTZY, -WUT, -WUTZY



Ref.	R.O. OEM
------	-------------

REC124550-35110 124550-35110  
124085-35113

**MOTORES / ENGINES / MOTORI**

3HM, F  
3HM35



Ref.	R.O. OEM
------	-------------

REC127695-35150 127695-35150  
127695-35160

**MOTORES / ENGINES / MOTORI**

4LHA-DTE, -DTP, -DTZE, -DTZP,  
-HTE, -HTP, -HTZE, -HTZP,  
-STE, -STP, -STZE, -STZP  
4LH-DTE, -DTZ, -HT, -HTZ,  
-HTZAY, -ST, -STE, -STZ,  
-STZAY, -UT, -UTZ, -UTZAY,  
-WST, -WSTZY  
6CX-ETE, -GT  
6CXM-ETE



Ref.	R.O. OEM
------	-------------

REC119005-35100 119005-35100  
119005-35151 109005-35170

**MOTORES / ENGINES / MOTORI**

4LH-HTE, -TE



Ref.	R.O. OEM
------	-------------

REC129150-35153 129150-35153  
129150-35170



**MOTORES / ENGINES / MOTORI**

2JH2-DTE 3JH25A  
4JH, -DTE, E, -HTE, -HTZ,  
-HTZAE, -TE, -TZ  
4JH2E, -HTE, -TE, -UTE  
4JH3-HTE, -TE  
4JH4E, AE  
4JH5E



Ref.	R.O. OEM
------	-------------

REC128633-35400 128633-35400

**MOTORES / ENGINES / MOTORI**

6GHA-ET



**JUNTAS BOMBA ACEITE  
OIL PUMP GASKETS  
GUARNIZIONE POMPE OLIO**

Ref.	R.O. OEM
------	-------------

REC128170-32030 128170-32030

**MOTORES / ENGINES / MOTORI**

1GM, L, Y-C  
1GM10



Ref.	R.O. OEM
------	-------------

REC121450-32021 121450-32021

**MOTORES / ENGINES / MOTORI**

2GM20, F 3GM30, F, F-YEU  
2GM 3GM  
2GM50F-YEU



Ref.	R.O. OEM
------	-------------

REC129120-35121 129120-35121

**MOTORES / ENGINES / MOTORI**

3JH3, E, E-YEU-E

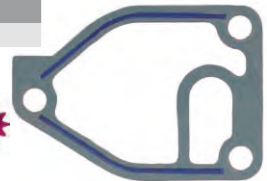

Ref.	R.O. OEM
------	-------------

REC129470-35040 129470-35040

**MOTORES / ENGINES / MOTORI**

3JH2, -TCE, E, L  
3JH3, E-YEU-E  
4LH-TE, -HTE, -DTE, -STE, -HT, -HTZ, -HTZAY,  
-DTZ, -UT, -UTZAY, -UT2, -ST, -STZAY, -STZ,  
-WST, -WSTZY  
4LHA-STE, -STP  
4LHS-STZE, -STZP, -DTE, -DTP, -DTZE, -DTZP,  
-HTE, -HTP, -HTZE, -HTZP



Ref.	R.O. OEM
------	-------------

REC129150-35042 129150-35042

**MOTORES / ENGINES / MOTORI**

3JH25A  
3JH40  
3JH4E  
4JH



Ref.	R.O. OEM
REC119000-32020	119000-32020

**MOTORES / ENGINES / MOTORI**  
 4LH-TE, -HTE, -DTE, -STE, -HT, -HTZ, -HTZAY,  
 -DTZ, -UT, -UTZAY, -UT2, -ST, -STZAY, -STZ,  
 -WST, -WSTZY  
 4LHA-STE, -STP  
 4LHS-STZE, -STZP, -DTE, -DTP, -DTZE, -DTZP,  
 -HTE, -HTP, -HTZE, -HTZP



**NEW**

**JUNTA SOPORTE FILTRO DE ACEITE**  
**OIL FILTER SUPPORT GASKET**  
**GUARNIZIONE SUPPORTO**  
**FILTRO OLIO**

Ref.	R.O. OEM
REC129470-35121	129470-35121

**MOTORES / ENGINES / MOTORI**  
 3JH2, -TCE, E, L  
 3JH3, E-YEU-E  
 4LH-TE, -HTE, -DTE, -STE, -HT, -HTZ,  
 -HTZAY, -DTZ, -UT, -UTZAY, -UT2, -ST,  
 -STZAY, -STZ, -WST, -WSTZY  
 4LHA-STE, -STP  
 4LHS-STZE, -STZP, -DTE, -DTP, -DTZE,  
 -DTZP, -HTE, -HTP, -HTZE, -HTZP



**NEW**

**FILTROS AIRE**  
**AIR FILTERS**  
**FILTRI ARIA**

Ref.	R.O. OEM
REC128170-12540	128170-12540

**MOTORES / ENGINES / MOTORI**  
 1GM  
 1GML



Ref.	R.O. OEM
REC128270-12540	128270-12540

**MOTORES / ENGINES / MOTORI**  
 2GM, LP, SZK  
 2GM20F, F-YEU, -YEU  
 3GM30, F, F-YEU



**NEW**

Ref.	R.O. OEM
REC124770-12540	124770-12540

**MOTORES / ENGINES / MOTORI**  
 3HM, F  
 3HM35

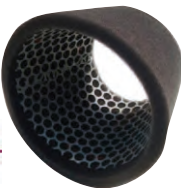

**NEW**

Ref.	R.O. OEM
REC129470-12330	129470-12330

**MOTORES / ENGINES / MOTORI**  
 3JH2-TCE  
 4JH2-DTE, E, -TE, -UTE  
 4JH3-DTE, -HTE, -TE  
 4JHE, -TE, -TZ



**NEW**

Ref.	R.O. OEM
REC119195-18880	119195-18880

**MOTORES / ENGINES / MOTORI**  
 4LHA-DTE, -DTP, -DTZE, -DTZP,  
 -HTE, -HTP, -HTZE, -HTZP, -STE,  
 -STP, -STZE, -STZP  
 6LY2-ST, -STE



Ref.	R.O. OEM
RECXN199611	XN199611

**MOTORES / ENGINES / MOTORI**  
 4LH-DTE, -DTZ, -HT, -HTE, -HTZ,  
 -HTZAY, -STE, -TE



**NEW**

Ref.	R.O. OEM
REC119593-18880	119593-18880

**MOTORES / ENGINES / MOTORI**  
 6CX-ETE  
 6LPA-DTP, -DTZP, -STP, -STZ  
 6LP-DT, -DTE, -DTZE, -DTZY,  
 -ST, -STE, -STZE, -STZY,  
 -WDT, -WDTZY  
 6LY2-STVY, -WDT, -WDTZY,  
 -WST, A-STE, A-STP, A-UTP  
 6LY2M-WDT, -WST  
 6LY3-ETP, -STP, -UTP  
 6LYA-STE, -STP, -UTE  
 6LYM-UTE, -STE, -UTEHD



6LY-ST, -STE, -STM, -STZY,  
 -UT, -UTE, -UTM, -UTZY,  
 -WST, -WSTZY, -WUT,  
 -WUTZY

Ref.	R.O. OEM
REC127692-18880	127692-18880

**MOTORES / ENGINES / MOTORI**  
 6CX-GT  
 6CXM-ETE



**NEW**

**SENSORES TEMPERATURA**  
**TEMPERATURA SENSORS**  
**SENSORI TEMPERATURA**

Ref.	R.O. OEM
REC127610-91350	127610-91350

**MOTORES / ENGINES / MOTORI**  
 2GM20F  
 2GMF-YEU  
 3GM30F, F-YEU,  
 3HMF  
 3JH25A  
 3JH2, E, L, -TCE  
 3JH3  
 4CH-DT  
 4JH, -TZ  
 4JH2E, -DTE, -HTE, -TE, -UTE  
 4JHA-DTE  
 4LHA-DTP, -DTZE, -DTZP, -HTE, -HTP,  
 -HTZE, -HTZP, -STE, -STP, -STZE, -STZP  
 4LH-DTE, -DTZ, -HT, -HTE, -HTZ, -HTZAY,  
 -ST, -STE, -STZ, -STZAY, -TE  
 6CX-ETE, M-ETE, 6GHA-ET, -ST, -STE

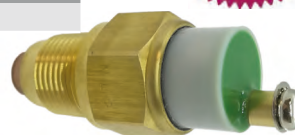

**NEW**

6GHAK-ST1, 6GHAM-STE  
 6GHD-ST  
 6KHL-ST  
 6LPA-DTP, -STP, -STZ  
 6LP-DT, -DTE, -DTZE, -DTZY, -ST, -STE,  
 -STZE, -STZY, WDT, -WDTZY  
 6LY2-ST, -WDT, -WDTZY, -WST  
 6LY2A-STE, -STP, -UTP  
 6LY2M-WDT, -WST  
 6LYA-STE, -STP, -UTE  
 6LYM-UTE, -STE  
 6LY-ST, -STE, -STM, -STZY, -UT, -UTE,  
 -UTM, -UTZY, -WST, -WSTZY, -WUT, -WUTZY

Ref.	R.O. OEM
REC128275-91340	128275-91340

**MOTORES / ENGINES / MOTORI**  
 1GM, L, Y-C  
 1GM10  
 2GM20, -YEU  
 2GM, LP, SZK



**NEW**

Ref.	R.O. OEM
REC120130-91370	120130-91370

**MOTORES / ENGINES / MOTORI**  
 3JH4E  
 3JH5AE, E  
 4JH3-DTE, -HTE, -TE  
 4JH4AE



**NEW**



# TURBOS TURBO TURBINE

	TURBO TURBO TURBINE	R.O. OEM	MODELO TURBO TURBO MODEL MODELLO TURBINE
4LH-HTE 4LH-TE	REC119171-18010	119171-18010	MY58
4LH-DTE	REC119173-18011	119173-18011	53269886292
4JH3-T	REC129671-18001	129671-18001	MYCZ
4LH-STE	REC119195-18031	119195-18031	MYAV
4LHA-DTZE 4LHA-DTE 4LHA-DTP	REC119173-18041	119173-18041	MYDH



	TURBO TURBO TURBINE	R.O. OEM	MODELO TURBO TURBO MODEL MODELLO TURBINE
4LH-HTE	REC119172-18011	119172-18011	MYBF
4JH-TE	REC129497-18000	129497-18000	MY29
4JH-DTE	REC129473-18000	129473-18000	MY34
4LHA-STP 4LHA-STE	REC119175-18031	119175-18031	MYDA
4LHA-HTE	REC119172-18030	119172-18030	MYDN



# MOTORES ARRANQUE STARTERS MOTORINO AVVIAMENTO

Ref.	R.O. OEM			DIENTES TOOTH DENTI
PH150-0004	124250-77012	12V	1.4 Kw	15 BENDIX
	129573-77010			
	171008-77010			
	171006-77010			
	121256-77011			
	124450-77011			
	124772-77010			
124772-77020				

**MOTORES / ENGINES / MOTORI**

- 3HM, F
- 3HM35
- 3JH2, E, L, TCE
- 3JH25A
- 3JH3
- 4JH, E, -HTE, -HTZ, -HTZAE, -TE, -TZ, -DTE
- 4JH2-DTE, E, -HTE, -TE, -UTE
- 4JH3-DTE, -HTE, -TE

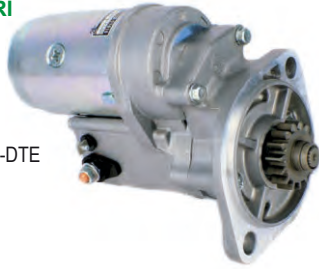

Ref.	R.O. OEM			DIENTES TOOTH DENTI
PH150-0005	119773-77010	12V	2.5 Kw	12 BENDIX

**MOTORES / ENGINES / MOTORI**

- 6LPA-DTP, -DTZP, -STP, -STZ
- 6LP-DT, , -DTE, -DTZE, -DTZY, -ST, -STE, -STZE, -STZY, -WDT, -WDTZY



Ref.	R.O. OEM			DIENTES TOOTH DENTI
PH140-0008	128170-77010	12V	1.0 Kw	9 BENDIX
	128170-77010D			

**MOTORES / ENGINES / MOTORI**

- 1GM
- 2GM20F, F-YEU, -YEU
- 3GM30, F, F-YEU



Ref.	R.O. OEM			DIENTES TOOTH DENTI
REC123500-77010	123500-77010	12V	3 Kw	11 BENDIX
	124610-77010			
	124610-77019			
	424610-77010			

**MOTORES / ENGINES / MOTORI**

- 6LY-STE, -UTE
- 6LYM-UTE, -STE
- 6LY2-STE
- 6LY2A-STP, -UTP
- 6LYA-STP, -STE, -UTE



Ref.	R.O. OEM			DIENTES TOOTH DENTI
PH140-0007	114362-77011	12V	0.8 Kw	8 BENDIX
	114362-77010			
	114361-77011			
	114399-77010			
	114399-77010			

**MOTORES / ENGINES / MOTORI**

- L40S
- L60S



Ref.	R.O. OEM			DIENTES TOOTH DENTI
REC121254-77012	121254-77010	12V	2.5 Kw	15 BENDIX
	121254-77011			
	121254-77012			
	121254-77019			
	129429-77010			
	129429-77011			
171058-77010				

**MOTORES / ENGINES / MOTORI**

- 4LHA-DTE, -DTP, -DTZE, -DTZP, -HTE, -HTP, -HTZE, -HTZP, -STE, -STP, -STZE, -STZP
- 4LH-DTE, -DTZ, -HT, -HTE, -HTZ, -HTZAY, -ST, -STE, -STZ, -STZAY, -TE, -UT, -UTZ, -UTZAY



Ref.	R.O. OEM			DIENTES TOOTH DENTI
PH140-0009	129698-77010	12V	1.4 Kw	11 BENDIX
	129608-77010			
	129242-77010			
	121370-77010			

**MOTORES / ENGINES / MOTORI**

- 1GM10
- 2GM20
- 3JH3, E-YEU-E, E
- 3QM
- 3QM30, F, H
- 2QM20



Ref.	R.O. OEM			DIENTES TOOTH DENTI
REC104211-77011	104211-77011	12V	1.0 Kw	9 BENDIX
	104211-77010			

**MOTORES / ENGINES / MOTORI**

- SB8
- SVE8
- YSE8
- YSM8
- YSM10
- YSE10
- SVE12
- SB12



# ALTERNADORES ALTERNATORS ALTERNATORI

Ref.	R.O. OEM		
PH300-0020	119836-77200	12V	40 A
	119836-77201		
	119612-77230		
	129930-77211		

Regulador interno y polea simple de serpentín. Tipo Hitachi  
Internal regulator and simple coil pulley.  
Type Hitachi  
Regolatore interno e puleggia a spirale semplice. Scriveri Hitachi



Ref.	R.O. OEM		
PH300-0002	119573-77200	12V	80 A
	119573-77201		
	129470-77200		
	129772-77200		

## MOTORES / ENGINES / MOTORI

2GM20, F, F-YEU, -YEU 4LH-DTE, -DTZ, -HT, -HTE, -HTZ, -HTZAY, -ST, -STE, -STZ, -STZAY, -TE, -UT, -UTZ, -UTZAY  
3JH4E  
3JH5AE, E  
3YM20  
4JH2-DTE, E, -HTE, -TE, -UTE  
4JH3-DTE, -HTE, -TE  
4JH4E, AE  
4JH5E  
4JH-DTE, E, -HTE  
4LHA-DTE, -DTP, -DTZE, -DTZP, -HTE, -HTP, -HTZE, -HTZP, -STE, -STP, -STZE, -STZP

Regulador interno y polea simple.  
Internal regulator and simple pulley.  
Regolatore interno e puleggia semplice.



Ref.	R.O. OEM		
PH300-0005	128270-77200	12V	35A
	128270-77201		
	128270-77202		
	128171-77200		

## MOTORES / ENGINES / MOTORI

1GM10 3JH2, E, L, -TCE  
1GML, Y-C 3JH25A  
2GM20 3JH3  
2GM20 4JH, -HTZ, -HTZAE, -TE, -TZ  
3HM, F

Regulador interno y polea simple.  
Internal regulator and simple pulley.  
Regolatore interno e puleggia semplice.



Ref.	R.O. OEM		
PH300-0018	119773-77200	12V	80A
	119773-77201		

## MOTORES / ENGINES / MOTORI

6LPA-DTP, -DTZP, -STP, -STZ  
6LP-DT, -DTE, -DTZE, -DTZY, -ST, -STE, -STZE, -STZY, -WDT, -WDTZY, -WST, -WSTZY, -DTZE1, -STZE1  
6LPA-STP2, -STZP2, -STZP3, -DTZEP1, -STZEP1, -STZYJ

Regulador interno y polea doble.  
Tipo Nippondenso.  
Internal regulator and double pulley.  
Type Nippondenso.  
Regolatore interno e puleggia doppia.  
Tipo Nippondenso.



## CORREAS ALTERNADOR ALTERNATOR BELT CINGHIE ALTERNATORE

NEW

Ref.	R.O. OEM	MOTORES ENGINES MOTORI	
REC251321-003000	251321-003000	2GMSZK	
REC25132-003100	25132-003100	2GM20, -YEU 2GM20	
REC25132-003700	25132-003700	2GM20F, F-YEU 3GM30, F-YEU	
REC128670-77350	128670-77350	3HM	
REC129612-42290E	129612-42290E	3YM20	
REC129940-42310E	129940-42310E	3JH3E-YEU-E 3JH4E	
REC128170-77350	128170-77350	1GM10 1GML 3GM 3HMF 3JH2, E, L, -TCE 3JH25A 3JH3	
REC25132-004500	25132-004500	4JH, -HTE, -HTZ, -HTZAE, -TE, -TZ 3JH5AE, E 4JHAE 4JH4E, AE 4JH5E	
REC25152-004300	25152-004300	4JH2-DTE, E, -HTE, -TE, -UTE 4JH3, -TE, -HTE 4JH-DTE	
REC25132-004600	25132-004600	4LHA-DTE, -DTP, -DTZE, -DTZP, -HTE, -HTP, -HTZE, -HTZP, -STE, -STP, -STZE, -STZP 4LH-DTE, -DTZ, -HT, -HTE, -HTZ, -HTZAY, -ST, -STE, -STZ, -STZAY, -TE, -UT, -UTZ, -UTZAY, -WST, -WSTZY 6LYA-STE, -UTE, -STP 6LY2A-STP, -UTP 6LY2M-WDT, -WST 6LYM-UTE, -STE, -UTEHD 6LY-STE 6LY2-STVY, -WDT, -WDTZY, -WST 6LY-ST, -STM, -STZY, -UT, -UTE, -UTM, -UTZY, -WST, -WSTZY, -WUT, -WUTZY	
REC121850-42280E	121850-42280E	6GHA-ET, -ST, -STE 6GHAK-ST1 6GHAM-STE 6GHD-ST	
REC25132-002700	25132-002700	Necesita 2 unidades por alternador It need 2 units per alternator Hai bisogno di 2 unità per alternatore	
REC25132-004250	25132-004250	6CX-ETE, -GT, M-ETE Necesita 2 unidades por alternador It need 2 units per alternator Hai bisogno di 2 unità per alternatore	
REC119775-77260	119775-77260 119773-77250	6LPA-DTP, -DTZP, -STP, -STZ 6LP-DT, -DTE, -DTZE, -DTZY, -ST, -STE, -STZE, -STZY, -WDT, -WDTZY Necesita 2 unidades por alternador It need 2 units per alternator Hai bisogno di 2 unità per alternatore	



## SOPORTES ELÁSTICOS FLEXIBLE ENGINE MOUNTS SUPPORTI ELASTICI

612

Ref.	R.O. OEM	CARGA MÁXIMA MAX LOAD CARICA MAX
GS38120	124770-12540	40 Kg / 88 lb

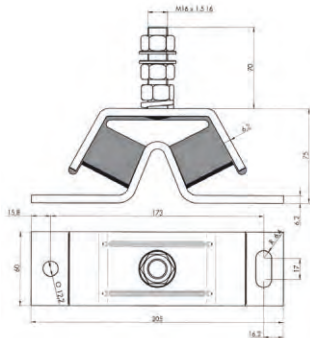

Ref.	R.O. OEM	CARGA MÁXIMA MAX LOAD CARICA MAX
GS38107	128270-08341	75 Kg / 165 lb

**MOTORES / ENGINES / MOTORI**  
2GM20, VE, B, F, FVE  
3GM30, B, C, F



Ref.	R.O. OEM	CARGA MÁXIMA MAX LOAD CARICA MAX
GS38108	124772-08341	100 Kg / 220 lb

**MOTORES / ENGINES / MOTORI**  
2GM20, VE, B, F, FVE  
3GM30, VE, B, C, F, FVE  
3JH2CE, -TCE, E, BE, S-TBE, G-TBE, S-TE, G-TE  
1GM10V  
2GM20V, FV  
3GM30V, FV  
3JHM35  
3HM35F

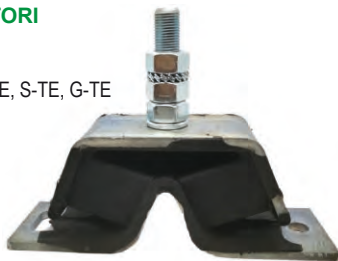

Ref.	R.O. OEM	CARGA MÁXIMA MAX LOAD CARICA MAX
GS38121	121370-08351	150 Kg / 330 lb

**MOTORES / ENGINES / MOTORI**  
3JH2CE, -TCE, E, BE, S-TBE, G-TBE, S-TE, G-TE  
4JH-DTE, -HTE, E, -TE  
4JH2E, -TE, -HTE, -DTE, -UTE, -UTB  
3JH2CE, -TCE, E, BE, S-TBE, G-TBE, S-TE, G-TE



## ÁNODOS ANODES ANODI

ZN	R.O. OEM
CMC272100-20030	27210-200300

**MOTORES / ENGINES / MOTORI**  
2GM20, F, F-YEU, -YEU  
2GM1P, SZK  
3GM30, F, F-YEU  
3HM, F  
3HM35  
6GHA-ET, -ST, -STE, K-ST1, M-STE  
6GHD-ST  
6KHL-ST



**COLA DE VELERO  
SAILBOAT GEARCASE  
PIEDE VELA**

ZN	AL	R.O. OEM
CM19642002652Z	CM19642002652A	196420-02652 196450-02492

**MOTORES / ENGINES / MOTORI**  
SD20  
SD25  
SD30  
SD31  
SD40  
SD50  
SD60



ZN	R.O. OEM
CMC10421141-300	104211-41300

**MOTORES / ENGINES / MOTORI**  
YSE8  
8FS  
YSE10  
12PSP



ZN	AL	R.O. OEM
CM19644002660KITZ	CM19644002660KITA	196440-02660 196450-02501

**MOTORES / ENGINES / MOTORI**  
SD20  
SD25  
SD30  
SD31  
SD40  
SD50  
SD60

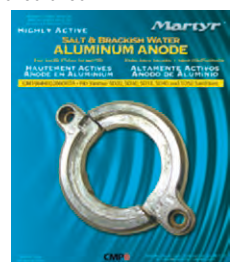

ZN	R.O. OEM
TEN01301	27210-200300

**MOTORES / ENGINES / MOTORI**  
 2GM20, F, F-YEU, -YEU  
 2GM1P, SZK  
 3GM30, F, F-YEU  
 3HM, F  
 3HM35  
 6GHA-ET, -ST, -STE, K-ST1, M-STE  
 6GHD-ST  
 6KHL-ST



ZN	R.O. OEM	KG (KG)
TEN01310	27200-400400	

**MOTORES / ENGINES / MOTORI**  
 6LA-DT, -DTE, -ST  
 6LAK-ST, -ST1  
 6LAH-ST, -STE  
 6LAA, E, -VTE  
 8LLA-DTE



ZN	R.O. OEM
TEN01302	

**MOTORES / ENGINES / MOTORI**  
 70-85 HP



ZN	R.O. OEM	KG (KG)
TEN01308	104211-41300	

**MOTORES / ENGINES / MOTORI**  
 SEALDRIVE



ZN	R.O. OEM
TEN01303	27210-200200

**MOTORES / ENGINES / MOTORI**  
 1GM, L, Y-C  
 1GM10  
 6GHA-ET, -ST, -STE, K-ST1, M-STE  
 6GHD-S  
 6KHL-ST



ZN	R.O. OEM	KG (KG)
TEN01304	196630-02670	

**MOTORES / ENGINES / MOTORI**  
 D27  
 D36



ZN	R.O. OEM
TEN01311	27200-300400

**MOTORES / ENGINES / MOTORI**  
 6GHA-ET, -ST, -STE, K-ST1, M-STE  
 6GHD-ST  
 6KHL-ST



ZN	R.O. OEM	KG (KG)
TEN01305/1	196440-02660 196450-02501	

**MOTORES / ENGINES / MOTORI**  
 SD20 SD40  
 SD25 SD50  
 SD30 SD60  
 SD31



ZN	R.O. OEM	KG (KG)
TEN01312	27210-200370	

**MOTORES / ENGINES / MOTORI**  
 6GHA-ET, -ST, -STE, K-ST1, M-STE  
 6GHD-ST  
 6CX-GT



ZN	R.O. OEM	KG (KG)
TENPLAC-1	196440-02690	

**MOTORES / ENGINES / MOTORI**  
 SD20 SD40  
 SD25 SD50  
 SD30 SD60  
 SD31



ZN	R.O. OEM	KG (KG)
TEN01306	27210-200550 177301-549000	

**MOTORES / ENGINES / MOTORI**  
 6LYM-UTEHD  
 6LY-ST, -STE, -STM, -STZY, -UT, -UTE, -UTM,  
 -UTZY, -WST, -WSTZY, -WUT, -WUTZY



ZN	R.O. OEM	KG (KG)
TEN01391-1	196350-02570	

**MOTORES / ENGINES / MOTORI**  
 ZT350  
 ZT370



ZN	R.O. OEM	KG (KG)
TEN01390-1	196350-02550	

**MOTORES / ENGINES / MOTORI**  
 ZT350  
 ZT370



ZN	R.O. OEM	KG (KG)
TEN01300	104211-41300	

**MOTORES / ENGINES / MOTORI**  
 YSE8  
 8FS  
 YSE10  
 12PSP



ZN	R.O. OEM	KG (KG)
TEN01393-1	196350-07360	

**MOTORES / ENGINES / MOTORI**  
 ZT350  
 ZT370



**TUERCA HÉLICE  
BLADE NUT  
DADO ELICA**

ZN	R.O. OEM	(KG)
TEN01392-1	196350-09910	



**NEW**

**MOTORES / ENGINES / MOTORI**

ZT350  
ZT370

**TIMÓN  
RUDDER  
TIMONE**

ZN	R.O. OEM	(KG)
TEN01319	196640-62680	



**NEW**

**MOTORES / ENGINES / MOTORI**

B63  
D36A  
D27A

**ALETA CABITACIÓN  
CABITATION FLAP  
FLAP CABINAZIONE**

ZN	R.O. OEM	(KG)
TEN01394-1	196350-02350	



**NEW**

**MOTORES / ENGINES / MOTORI**

ZT350  
ZT370

**KITS TECNOSEAL**

KIT	ÁNODO ZN ZN ANODE ANODO ZN	R.O. OEM	TAPÓN PLUG TAPPO	(KG)
TEN01317T		119574-18790		
	TEN01317	177301-54900		
TEN01317TP				

**MOTORES / ENGINES / MOTORI**

4LHA-STZP  
4LH-DTE, -DTZ, -HT, -HTE, -HTZ, -HTZAY, -ST,  
-STE, -STZ, -STZAY, -TE, -UT, -UTZ, -UTZAY

**NEW**



KIT	ÁNODO ZN ZN ANODE ANODO ZN	R.O. OEM	TAPÓN PLUG TAPPO	(KG)
TEN01316T		119574-44150		
TEN01318T				
	TEN01316	27210-200370		
	TEN01318			
TEN01316TP TEN01318TP				

**MOTORES / ENGINES / MOTORI**

4LHA-DTE, -DTP, -DTZE, -DTZP, -HTE, -HTP,  
-HTZE, -HTZP, -STE, -STP, -STZE

**NEW**



**HÉLICES ALUMINO E INOXIDABLES DE 3 Y 4 PALAS  
3 & 4 BLADE ALUMINUM & STAINLESS STEEL PROPELLERS  
ELICHE ALLUMINIO E INOX DA 3 E 4 PALE**

SISTEMA CODIGO REFERENCIAS  
PART NO. CODING SYSTEM  
SISTEMA DI CODICE

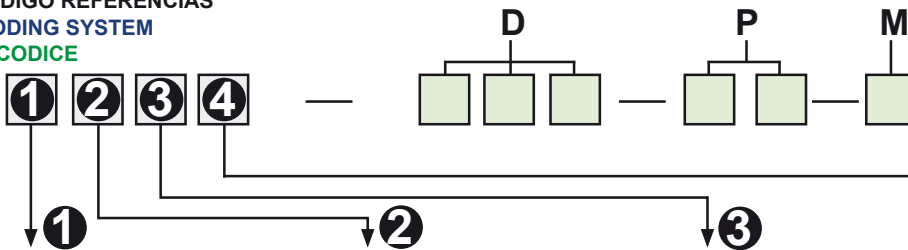

<ol style="list-style-type: none"> <li>Mercury, Mariner</li> <li>Johnson, Evinrude</li> <li>Yamaha</li> <li>Suzuki</li> <li>Tohatsu</li> <li></li> <li></li> <li>Volvo Penta</li> <li>Rubex System</li> </ol>	<ol style="list-style-type: none"> <li>0.5, 6, 8 and 9.8 HP Grupo /Group / Gruppo</li> <li>A Grupo /Group / Gruppo</li> <li>B Grupo /Group / Gruppo</li> <li>C Grupo /Group / Gruppo</li> <li>D Grupo /Group / Gruppo</li> <li>E Grupo /Group / Gruppo</li> <li>F Grupo /Group / Gruppo</li> <li>VP (Cubo std./Std. Hub / mozzo std.)</li> <li>VP (Cubo largo /Long Hub / mozzo lungo)</li> </ol>	<ol style="list-style-type: none"> <li>Aluminio /Aluminum / Alluminio</li> <li>Saturn Acero inox. /S.S. / Acciaio inox.</li> <li>New Saturn Acero inox. /S.S. / Acciaio inox.</li> <li>Titan Acero inox. /S.S. / Acciaio inox.</li> <li>HR Titan Acero inox. /S.S. / Acciaio inox.</li> </ol>	<ol style="list-style-type: none"> <li>3R Rubber Hub</li> <li>3L Rubber Hub</li> <li>4R Rubber Hub</li> <li>4L Rubber Hub</li> </ol>
---	---	---	--

Ejemplo / Note / Esempio

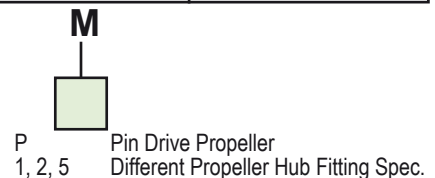
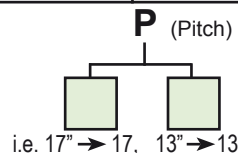
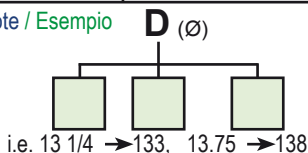



**AMITA 3**

- Helices de aluminio de 3 palas con núcleo de goma de gran resistencia.
- 3 blade aluminum propeller with heavy duty rubber hub.
- Eliche in alluminio a 3 pale con mozzi in gomma ad alta resistenza.



**AMITA 3-E PLUS**

- Helices de aluminio de 3 palas con núcleo de goma de gran resistencia. Palas más largas que Amita3 para un empuje superior. Ideal para barcos pesados.
- 3 blade aluminum propeller with heavy duty rubber hub. Larger blades than Amita3 for superior thrust. Ideal for heavy boats.
- Eliche in alluminio a 3 pale con mozzi in gomma ad alta resistenza. Lame più grandi di Amita3 per una spinta superiore. Ideale per imbarcazioni pesanti.



HP	R.O. OEM	B	D	P	R	TIPO TYPE	ALUMINIO ALUMINIUM ALLUMINIO	
							AMITA 3	AMITA 3-E PLUS
SZ110, 111, 160, 161 Cubo standard / Standard Hub / Mozzo standard 9,5 mm		3	15.5	15	L	Alum.	SOL8712-150-15	
		3	14.8	17	L	Alum.	SOL8712-148-17	
		3	14.5	19	L	Alum.	SOL8712-148-17	
		3	14.3	21	L	Alum.	SOL8712-143-21	
SZ200, 251, 301 Cubo standard / Standard Hub / Mozzo standard 11,5 mm		3	15	15	L	Alum.	SOL8812-150-15	
		3	14.8	17	L	Alum.	SOL8812-148-17	
		3	14.5	19	L	Alum.	SOL8812-145-19	
		3	14.3	21	L	Alum.	SOL8812-143-21	
		3	14.2	23	L	Alum.	SOL8812-142-23	
		3	15.8	15	L	Alum.		SOL8812-158-15
		3	15.5	17	L	Alum.		SOL8812-155-17
		3	15.3	19	L	Alum.		SOL8812-153-19
3	15.3	21	L	Alum.		SOL8812-153-21		



**B3**

**HELICES DE ACERO INOXIDABLE**

Para Colas YANMAR ZT350 y ZT370  
Hélices delanteras de 4 palas. Hélices traseras de 3 palas.  
19 estrías y escape a través de la hélice.

**STAINLESS STEEL PROPELLERS**

For YANMAR sterndrives ZT350 & ZT370  
Front propellers with 4 blades.  
Rear propellers with 3 blades.  
19 Tooth Spline and Thru hub exhaust.

**ELICHE IN ACCIAIO INOX**

Per piedi YANMAR ZT350 e ZT370  
Elica anteriori di 4 pale. Elica posteriore di 3 pale.  
19 denti, scarico all'elica.



R.O. OEM	POSICIÓN POSITON POSIZIONE		B	D	P	R	TIPO TYPE	ALUMINIO ALUMINIUM ALLUMINIO
	DELANTERO FRONT ANTERIORE	TRASERO REAR POSTERIORE						
196350-09400	✓		4	16"	20	L	Inox.	SOL1654-160-20
196350-09400		✓	3	14 <sup>3/8"</sup>	20	R	Inox.	SOL1651-144-20
	✓		4	16"	21	L	Inox.	SOL1654-160-21
		✓	3	14 <sup>3/8"</sup>	21	R	Inox.	SOL1651-144-21
196350-09420	✓		4	15 <sup>3/4"</sup>	22	L	Inox.	SOL1654-158-22
196350-09720		✓	3	14 <sup>1/4"</sup>	22	R	Inox.	SOL1651-143-22
	✓		4	15 <sup>3/4"</sup>	23	L	Inox.	SOL1654-158-23
		✓	3	14 <sup>1/4"</sup>	23	R	Inox.	SOL1651-143-23
196350-09440	✓		4	15 <sup>1/2"</sup>	24	L	Inox.	SOL1654-155-24
196350-09740		✓	3	14"	24	R	Inox.	SOL1651-140-24
	✓		4	15 <sup>1/2"</sup>	25	L	Inox.	SOL1654-155-25
		✓	3	14"	25	R	Inox.	SOL1651-140-25
196350-09460	✓		4	15 <sup>1/2"</sup>	26	L	Inox.	SOL1654-155-26
196350-09760		✓	3	14"	26	R	Inox.	SOL1651-140-26
	✓		4	15"	27	L	Inox.	SOL1654-150-27
		✓	3	13 <sup>3/4"</sup>	27	R	Inox.	SOL1651-140-27
196350-09480	✓		4	15"	28	L	Inox.	SOL1654-150-28
196350-09780		✓	3	13 <sup>3/4"</sup>	28	R	Inox.	SOL1651-138-28

B= PALAS / Blades / Pale  
D= DIÁMETRO / Diametre / Diametro  
P= PASO / Pich / Passo

R=ROTACIÓN / Rotation / Rotazione  
(R) Derecha / Right / DX  
(L) Izquierda / Left / SX



# GUÍA MANTENIMIENTO MAINTENANCE GUIDE GUIDA DI MANUTENZIONE

Modelo Model Modello	DESCRIPCIÓN	DESCRIPTION	DESCRIZIONE	Ref.
1GM 1GM10	FILTRO ACEITE	OIL FILTER	FILTRO OLIO	REC119305-35151
	FILTRO COMBUSTIBLE	FUEL FILTER	FILTRO COMBUSTIBILE	REC104500-55710
	FILTRO AIRE	AIR FILTER	FILTRO ARIA	REC128170-12540
	IMPULSOR	IMPELLER	GIRANTE	REC128170-42070
	TERMOSTATO	THERMOSTAT	TERMOSTATO	REC105582-49200
	CORREA ALTERNADOR	ALTERNATOR BELT	CINGHIA ALTERNATORE	REC128170-77350
	ÁNODO	ANODE	ANODO	TEN01303
1GML	FILTRO ACEITE	OIL FILTER	FILTRO OLIO	REC119305-35170
	FILTRO COMBUSTIBLE	FUEL FILTER	FILTRO COMBUSTIBILE	REC104500-55710
	FILTRO AIRE	AIR FILTER	FILTRO ARIA	REC128170-12540
	IMPULSOR	IMPELLER	GIRANTE	REC128170-42070
	TERMOSTATO	THERMOSTAT	TERMOSTATO	REC105582-49200
	CORREA ALTERNADOR	ALTERNATOR BELT	CINGHIA ALTERNATORE	REC128170-77350
	ÁNODO	ANODE	ANODO	TEN01303
1GMY-C	FILTRO ACEITE	OIL FILTER	FILTRO OLIO	REC119305-35151
	FILTRO COMBUSTIBLE	FUEL FILTER	FILTRO COMBUSTIBILE	REC104500-55710
	FILTRO AIRE	AIR FILTER	FILTRO ARIA	REC128171-12540
	IMPULSOR	IMPELLER	GIRANTE	REC128170-42070
	TERMOSTATO	THERMOSTAT	TERMOSTATO	REC105582-49200
	CORREA ALTERNADOR	ALTERNATOR BELT	CINGHIA ALTERNATORE	REC25117-003151
	ÁNODO	ANODE	ANODO	TEN01303
2GM20	FILTRO ACEITE	OIL FILTER	FILTRO OLIO	REC119305-35151
	FILTRO COMBUSTIBLE	FUEL FILTER	FILTRO COMBUSTIBILE	REC104500-55710
	FILTRO AIRE	AIR FILTER	FILTRO ARIA	REC128270-12540
	IMPULSOR	IMPELLER	GIRANTE	REC3586494
	TERMOSTATO	THERMOSTAT	TERMOSTATO	REC105582-49200
	CORREA ALTERNADOR	ALTERNATOR BELT	CINGHIA ALTERNATORE	REC25132-003100
	CORREA BOMBA	PUMP BELT	CINGHIA POMPA	REC104511-78780
ÁNODO	ANODE	ANODO	CMC272100-20030	
2GM20F	FILTRO ACEITE	OIL FILTER	FILTRO OLIO	REC119305-35151
	FILTRO COMBUSTIBLE	FUEL FILTER	FILTRO COMBUSTIBILE	REC104500-55710
	FILTRO AIRE	AIR FILTER	FILTRO ARIA	REC128270-12540
	IMPULSOR	IMPELLER	GIRANTE	REC22779-0001
	TERMOSTATO	THERMOSTAT	TERMOSTATO	REC121750-49800
	CORREA ALTERNADOR	ALTERNATOR BELT	CINGHIA ALTERNATORE	REC124732-42290
	CORREA BOMBA	PUMP BELT	CINGHIA POMPA	REC104511-78780
ÁNODO	ANODE	ANODO	CMC272100-20030	
2GM20F-YEU	FILTRO ACEITE	OIL FILTER	FILTRO OLIO	REC119305-35151
	FILTRO COMBUSTIBLE	FUEL FILTER	FILTRO COMBUSTIBILE	REC104500-55710
	FILTRO AIRE	AIR FILTER	FILTRO ARIA	REC128270-12540
	IMPULSOR	IMPELLER	GIRANTE	REC653-0001
	TERMOSTATO	THERMOSTAT	TERMOSTATO	REC121750-49800
	CORREA ALTERNADOR	ALTERNATOR BELT	CINGHIA ALTERNATORE	REC25132-003700
	CORREA BOMBA	PUMP BELT	CINGHIA POMPA	REC104511-78780
ÁNODO	ANODE	ANODO	CMC272100-20030	
2GM20-YEU	FILTRO ACEITE	OIL FILTER	FILTRO OLIO	REC119305-35151
	FILTRO COMBUSTIBLE	FUEL FILTER	FILTRO COMBUSTIBILE	REC104500-55710
	FILTRO AIRE	AIR FILTER	FILTRO ARIA	REC128270-12540
	IMPULSOR	IMPELLER	GIRANTE	REC653-0001
	TERMOSTATO	THERMOSTAT	TERMOSTATO	REC105582-49200
	CORREA ALTERNADOR	ALTERNATOR BELT	CINGHIA ALTERNATORE	REC25132-003100
	CORREA BOMBA	PUMP BELT	CINGHIA POMPA	REC104511-78780
ÁNODO	ANODE	ANODO	CMC272100-20030	
2GM1P	FILTRO ACEITE	OIL FILTER	FILTRO OLIO	REC119305-35151
	FILTRO COMBUSTIBLE	FUEL FILTER	FILTRO COMBUSTIBILE	REC104500-55710
	FILTRO AIRE	AIR FILTER	FILTRO ARIA	REC128270-12540
	CORREA ALTERNADOR	ALTERNATOR BELT	CINGHIA ALTERNATORE	REC25132-003100
	ÁNODO	ANODE	ANODO	CMC272100-20030
2GMSZK	FILTRO ACEITE	OIL FILTER	FILTRO OLIO	REC119305-35151
	FILTRO COMBUSTIBLE	FUEL FILTER	FILTRO COMBUSTIBILE	REC121750-55701
	FILTRO AIRE	AIR FILTER	FILTRO ARIA	REC128270-12540
	IMPULSOR	IMPELLER	GIRANTE	REC3586494
	TERMOSTATO	THERMOSTAT	TERMOSTATO	REC105582-49200
	CORREA ALTERNADOR	ALTERNATOR BELT	CINGHIA ALTERNATORE	REC25132-003000
	CORREA BOMBA	PUMP BELT	CINGHIA POMPA	REC128695-42780
ÁNODO	ANODE	ANODO	CMC272100-20030	
3GM30	FILTRO ACEITE	OIL FILTER	FILTRO OLIO	REC119305-35151
	FILTRO COMBUSTIBLE	FUEL FILTER	FILTRO COMBUSTIBILE	REC104500-55710
	FILTRO AIRE	AIR FILTER	FILTRO ARIA	REC128270-12540
	IMPULSOR	IMPELLER	GIRANTE	REC3586494
	TERMOSTATO	THERMOSTAT	TERMOSTATO	REC105582-49200
	ÁNODO	ANODE	ANODO	CMC272100-20030
3GM30F	FILTRO ACEITE	OIL FILTER	FILTRO OLIO	REC119305-35151
	FILTRO COMBUSTIBLE	FUEL FILTER	FILTRO COMBUSTIBILE	REC104500-55710
	FILTRO AIRE	AIR FILTER	FILTRO ARIA	REC128270-12540
	IMPULSOR	IMPELLER	GIRANTE	REC22779-0001
	TERMOSTATO	THERMOSTAT	TERMOSTATO	REC121750-49800
	CORREA ALTERNADOR	ALTERNATOR BELT	CINGHIA ALTERNATORE	REC104511-78780

Modelo Modelo Modelo	DESCRIPCIÓN	DESCRIPTION	DESCRIZIONE	Ref.
3GM30F-YEU	FILTRO ACEITE	OIL FILTER	FILTRO OLIO	REC119305-35151
	FILTRO COMBUSTIBLE	FUEL FILTER	FILTRO COMBUSTIBILE	REC104500-55710
	FILTRO AIRE	AIR FILTER	FILTRO ARIA	REC128270-12540
	IMPULSOR	IMPELLER	GIRANTE	REC653-0001
	TERMOSTATO	THERMOSTAT	TERMOSTATO	REC121750-49800
	CORREA ALTERNADOR	ALTERNATOR BELT	CINGHIA ALTERNATORE	REC25132-003700
	CORREA BOMBA	PUMP BELT	CINGHIA POMPA	REC104511-78780
3HM	FILTRO ACEITE	OIL FILTER	FILTRO OLIO	REC124550-35110
	FILTRO COMBUSTIBLE	FUEL FILTER	FILTRO COMBUSTIBILE	REC104500-55710
	FILTRO AIRE	AIR FILTER	FILTRO ARIA	REC128270-12540
	IMPULSOR	IMPELLER	GIRANTE	REC22779-0001
	TERMOSTATO	THERMOSTAT	TERMOSTATO	REC105582-49200
	CORREA ALTERNADOR	ALTERNATOR BELT	CINGHIA ALTERNATORE	REC128670-77350
	CORREA BOMBA	PUMP BELT	CINGHIA POMPA	REC104511-78780
ÁNODO	ANODE	ANODO	CMC272100-20030	
3HM35	FILTRO ACEITE	OIL FILTER	FILTRO OLIO	REC124550-35110
	FILTRO COMBUSTIBLE	FUEL FILTER	FILTRO COMBUSTIBILE	REC104500-55710
	FILTRO AIRE	AIR FILTER	FILTRO ARIA	REC128270-12540
	IMPULSOR	IMPELLER	GIRANTE	REC22779-0001
	TERMOSTATO	THERMOSTAT	TERMOSTATO	REC105582-49200
	CORREA ALTERNADOR	ALTERNATOR BELT	CINGHIA ALTERNATORE	REC123672-77370
	CORREA BOMBA	PUMP BELT	CINGHIA POMPA	REC104511-78780
ÁNODO	ANODE	ANODO	CMC272100-20030	
3HMF	FILTRO ACEITE	OIL FILTER	FILTRO OLIO	REC124550-35110
	FILTRO COMBUSTIBLE	FUEL FILTER	FILTRO COMBUSTIBILE	REC104500-55710
	FILTRO AIRE	AIR FILTER	FILTRO ARIA	REC128270-12540
	IMPULSOR	IMPELLER	GIRANTE	REC22779-0001
	TERMOSTATO	THERMOSTAT	TERMOSTATO	REC105582-49200
	CORREA ALTERNADOR	ALTERNATOR BELT	CINGHIA ALTERNATORE	REC128695-44780
	CORREA BOMBA	PUMP BELT	CINGHIA POMPA	REC104511-78780
ÁNODO	ANODE	ANODO	CMC272100-20030	
3JH2	FILTRO ACEITE	OIL FILTER	FILTRO OLIO	REC119305-35151
	FILTRO COMBUSTIBLE	FUEL FILTER	FILTRO COMBUSTIBILE	REC129470-55703
	IMPULSOR	IMPELLER	GIRANTE	REC21213660
	TERMOSTATO	THERMOSTAT	TERMOSTATO	REC129470-49801
	CORREA ALTERNADOR	ALTERNATOR BELT	CINGHIA ALTERNATORE	REC25132-004500
3JH25A	FILTRO ACEITE	OIL FILTER	FILTRO OLIO	REC129150-35153
	FILTRO COMBUSTIBLE	FUEL FILTER	FILTRO COMBUSTIBILE	REC129470-55703
	IMPULSOR	IMPELLER	GIRANTE	REC21213660
	TERMOSTATO	THERMOSTAT	TERMOSTATO	REC129470-49801
	CORREA ALTERNADOR	ALTERNATOR BELT	CINGHIA ALTERNATORE	REC25132-004500
3JH2E 3JH2L	FILTRO ACEITE	OIL FILTER	FILTRO OLIO	REC119305-35151
	FILTRO COMBUSTIBLE	FUEL FILTER	FILTRO COMBUSTIBILE	REC129470-55703
	IMPULSOR	IMPELLER	GIRANTE	REC129470-49801
	TERMOSTATO	THERMOSTAT	TERMOSTATO	REC105582-49200
	CORREA ALTERNADOR	ALTERNATOR BELT	CINGHIA ALTERNATORE	REC25132-004500
3JH2-TCE	FILTRO ACEITE	OIL FILTER	FILTRO OLIO	REC119305-35151
	FILTRO COMBUSTIBLE	FUEL FILTER	FILTRO COMBUSTIBILE	REC129470-55703
	FILTRO AIRE	AIR FILTER	FILTRO ARIA	REC129470-12330
	IMPULSOR	IMPELLER	GIRANTE	REC21213660
	TERMOSTATO	THERMOSTAT	TERMOSTATO	REC129470-49801
CORREA ALTERNADOR	ALTERNATOR BELT	CINGHIA ALTERNATORE	REC25132-004500	
3JH3	FILTRO ACEITE	OIL FILTER	FILTRO OLIO	REC129150-35151
	FILTRO COMBUSTIBLE	FUEL FILTER	FILTRO COMBUSTIBILE	REC129470-55701
	IMPULSOR	IMPELLER	GIRANTE	REC21213660
	TERMOSTATO	THERMOSTAT	TERMOSTATO	REC129470-49801
	CORREA ALTERNADOR	ALTERNATOR BELT	CINGHIA ALTERNATORE	REC25132-004500
3JH3E-YEU-E 3JH4E	FILTRO ACEITE	OIL FILTER	FILTRO OLIO	REC119305-35151
	FILTRO COMBUSTIBLE	FUEL FILTER	FILTRO COMBUSTIBILE	REC129470-55703
	IMPULSOR	IMPELLER	GIRANTE	REC21213660
	TERMOSTATO	THERMOSTAT	TERMOSTATO	REC129470-49801
	CORREA ALTERNADOR	ALTERNATOR BELT	CINGHIA ALTERNATORE	REC171087-42280
3YM20	FILTRO ACEITE	OIL FILTER	FILTRO OLIO	REC119305-35151
	FILTRO COMBUSTIBLE	FUEL FILTER	FILTRO COMBUSTIBILE	REC104500-55710
	FILTRO AIRE	AIR FILTER	FILTRO ARIA	REC128270-12540
	IMPULSOR	IMPELLER	GIRANTE	REC653-0001
	TERMOSTATO	THERMOSTAT	TERMOSTATO	REC128990-49800
	CORREA ALTERNADOR	ALTERNATOR BELT	CINGHIA ALTERNATORE	REC129612-42290
3YM27A	FILTRO ACEITE	OIL FILTER	FILTRO OLIO	REC119305-35160
	FILTRO COMBUSTIBLE	FUEL FILTER	FILTRO COMBUSTIBILE	REC104500-55710
	FILTRO AIRE	AIR FILTER	FILTRO ARIA	REC128991-12500
	IMPULSOR	IMPELLER	GIRANTE	REC128991-42200
	TERMOSTATO	THERMOSTAT	TERMOSTATO	REC128990-49800
	CORREA ALTERNADOR	ALTERNATOR BELT	CINGHIA ALTERNATORE	REC104511-78780
3YM30	FILTRO ACEITE	OIL FILTER	FILTRO OLIO	REC119305-35151
	FILTRO COMBUSTIBLE	FUEL FILTER	FILTRO COMBUSTIBILE	REC104500-55710
	FILTRO AIRE	AIR FILTER	FILTRO ARIA	REC128270-12540
	IMPULSOR	IMPELLER	GIRANTE	REC653-0001
	TERMOSTATO	THERMOSTAT	TERMOSTATO	REC128990-49800
	CORREA BOMBA	PUMP BELT	CINGHIA POMPA	REC128990-77350
ÁNODO	ANODE	ANODO	CMC272100-20030	

Modelo Model Modello	DESCRIPCIÓN	DESCRIPTION	DESCRIZIONE	Ref.
3YM30AE	FILTRO ACEITE	OIL FILTER	FILTRO OLIO	REC119305-35160
	FILTRO COMBUSTIBLE	FUEL FILTER	FILTRO COMBUSTIBILE	REC104500-55710
	FILTRO AIRE	AIR FILTER	FILTRO ARIA	REC128270-12540
	IMPULSOR	IMPELLER	GIRANTE	REC128990-42200
	TERMOSTATO	THERMOSTAT	TERMOSTATO	REC121750-49800
	CORREA ALTERNADOR	ALTERNATOR BELT	CINGHIA ALTERNATORE	REC128695-44780
	CORREA BOMBA	PUMP BELT	CINGHIA POMPA	REC25111-002100
4CH-DT	FILTRO ACEITE	OIL FILTER	FILTRO OLIO	REC127695-35150
	FILTRO COMBUSTIBLE	FUEL FILTER	FILTRO COMBUSTIBILE	REC41650-550810
	IMPULSOR	IMPELLER	GIRANTE	REC127610-42200
	TERMOSTATO	THERMOSTAT	TERMOSTATO	REC123682-48601
	CORREA ALTERNADOR	ALTERNATOR BELT	CINGHIA ALTERNATORE	REC124722-42290(2)
	CORREA BOMBA	PUMP BELT	CINGHIA POMPA	REC104511-78780
	ÁNODO	ANODE	ANODO	CMC272100-20030
4JH	FILTRO ACEITE	OIL FILTER	FILTRO OLIO	REC129150-35150
	FILTRO COMBUSTIBLE	FUEL FILTER	FILTRO COMBUSTIBILE	REC41650-550800
	IMPULSOR	IMPELLER	GIRANTE	REC129470-42531
	TERMOSTATO	THERMOSTAT	TERMOSTATO	REC129470-49801
	CORREA ALTERNADOR	ALTERNATOR BELT	CINGHIA ALTERNATORE	REC25132-004500
	CORREA BOMBA	PUMP BELT	CINGHIA POMPA	REC104511-78780
3HMF	FILTRO ACEITE	OIL FILTER	FILTRO OLIO	REC124550-35110
	FILTRO COMBUSTIBLE	FUEL FILTER	FILTRO COMBUSTIBILE	REC104500-55710
	FILTRO AIRE	AIR FILTER	FILTRO ARIA	REC128270-12540
	IMPULSOR	IMPELLER	GIRANTE	REC22779-0001
	TERMOSTATO	THERMOSTAT	TERMOSTATO	REC105582-49200
	CORREA ALTERNADOR	ALTERNATOR BELT	CINGHIA ALTERNATORE	REC128695-44780
	CORREA BOMBA	PUMP BELT	CINGHIA POMPA	REC104511-78780
	ÁNODO	ANODE	CMC272100-20030	
4JH2-DTE	FILTRO ACEITE	OIL FILTER	FILTRO OLIO	REC129150-35153
	FILTRO COMBUSTIBLE	FUEL FILTER	FILTRO COMBUSTIBILE	REC129470-55703
	FILTRO AIRE	AIR FILTER	FILTRO ARIA	REC129470-12330
	IMPULSOR	IMPELLER	GIRANTE	REC21213660
	TERMOSTATO	THERMOSTAT	TERMOSTATO	REC121750-49800
	CORREA ALTERNADOR	ALTERNATOR BELT	CINGHIA ALTERNATORE	REC25132-004600
4JH2E 4JH2-HTE 4JH2-TE	FILTRO ACEITE	OIL FILTER	FILTRO OLIO	REC129150-35153
	FILTRO COMBUSTIBLE	FUEL FILTER	FILTRO COMBUSTIBILE	REC129470-55703
	FILTRO AIRE	AIR FILTER	FILTRO ARIA	REC129470-12330
	IMPULSOR	IMPELLER	GIRANTE	REC21213660
	TERMOSTATO	THERMOSTAT	TERMOSTATO	REC129470-49801
	CORREA ALTERNADOR	ALTERNATOR BELT	CINGHIA ALTERNATORE	REC25132-004600
4JH2-UTE 4JH3-TE	FILTRO ACEITE	OIL FILTER	FILTRO OLIO	REC129150-35153
	FILTRO COMBUSTIBLE	FUEL FILTER	FILTRO COMBUSTIBILE	REC129574-55711
	FILTRO AIRE	AIR FILTER	FILTRO ARIA	REC129470-12330
	IMPULSOR	IMPELLER	GIRANTE	REC21213660
	TERMOSTATO	THERMOSTAT	TERMOSTATO	REC129470-49801
	CORREA ALTERNADOR	ALTERNATOR BELT	CINGHIA ALTERNATORE	REC25132-004600
4JH3-DTE	FILTRO ACEITE	OIL FILTER	FILTRO OLIO	REC129150-35170
	FILTRO COMBUSTIBLE	FUEL FILTER	FILTRO COMBUSTIBILE	REC129574-55711
	FILTRO AIRE	AIR FILTER	FILTRO ARIA	REC129470-12330
	IMPULSOR	IMPELLER	GIRANTE	REC129670-42531
	TERMOSTATO	THERMOSTAT	TERMOSTATO	REC129470-49801
	CORREA ALTERNADOR	ALTERNATOR BELT	CINGHIA ALTERNATORE	REC25132-004600 (normal) REC129673-77680 (serp.)
4JH3-HTE	FILTRO ACEITE	OIL FILTER	FILTRO OLIO	REC129150-35153
	FILTRO COMBUSTIBLE	FUEL FILTER	FILTRO COMBUSTIBILE	REC129574-55711
	FILTRO AIRE	AIR FILTER	FILTRO ARIA	REC129470-12330
	IMPULSOR	IMPELLER	GIRANTE	REC21213660
	TERMOSTATO	THERMOSTAT	TERMOSTATO	REC129470-49801
	CORREA ALTERNADOR	ALTERNATOR BELT	CINGHIA ALTERNATORE	REC25132-004600 (normal) REC129673-77680 (serp.)
4JH4E	FILTRO ACEITE	OIL FILTER	FILTRO OLIO	REC129150-35153
	FILTRO COMBUSTIBLE	FUEL FILTER	FILTRO COMBUSTIBILE	REC129470-55703
	IMPULSOR	IMPELLER	GIRANTE	REC21213660
	TERMOSTATO	THERMOSTAT	TERMOSTATO	REC129470-49801
	CORREA ALTERNADOR	ALTERNATOR BELT	CINGHIA ALTERNATORE	REC25152-004300
4JH-DTE	FILTRO ACEITE	OIL FILTER	FILTRO OLIO	REC129150-35153
	FILTRO COMBUSTIBLE	FUEL FILTER	FILTRO COMBUSTIBILE	REC129470-55703
	IMPULSOR	IMPELLER	GIRANTE	REC21213660
	TERMOSTATO	THERMOSTAT	TERMOSTATO	REC129470-49801
	CORREA ALTERNADOR	ALTERNATOR BELT	CINGHIA ALTERNATORE	REC25132-004600
4JHE	FILTRO ACEITE	OIL FILTER	FILTRO OLIO	REC129150-35153
	FILTRO COMBUSTIBLE	FUEL FILTER	FILTRO COMBUSTIBILE	REC129470-55703
	FILTRO AIRE	AIR FILTER	FILTRO ARIA	REC129470-12330
	IMPULSOR	IMPELLER	GIRANTE	REC21213660
	TERMOSTATO	THERMOSTAT	TERMOSTATO	REC129470-49801
	CORREA ALTERNADOR	ALTERNATOR BELT	CINGHIA ALTERNATORE	REC25132-004600
4JH-HTE	FILTRO ACEITE	OIL FILTER	FILTRO OLIO	REC129150-35153
	FILTRO COMBUSTIBLE	FUEL FILTER	FILTRO COMBUSTIBILE	REC129470-55703
	IMPULSOR	IMPELLER	GIRANTE	REC21213660
	TERMOSTATO	THERMOSTAT	TERMOSTATO	REC129470-49801
	CORREA ALTERNADOR	ALTERNATOR BELT	CINGHIA ALTERNATORE	REC25132-004500
4JH-HTZ 4JH-HTZAE	FILTRO ACEITE	OIL FILTER	FILTRO OLIO	REC129150-35150
	FILTRO COMBUSTIBLE	FUEL FILTER	FILTRO COMBUSTIBILE	REC129470-55703
	IMPULSOR	IMPELLER	GIRANTE	REC21213660
	TERMOSTATO	THERMOSTAT	TERMOSTATO	REC129470-49801
	CORREA ALTERNADOR	ALTERNATOR BELT	CINGHIA ALTERNATORE	REC25132-004500

Modelo Modelo Modelo	DESCRIPCIÓN	DESCRIPTION	DESCRIZIONE	Ref.
4JH-TE 4JH-TZ	FILTRO ACEITE	OIL FILTER	FILTRO OLIO	REC129150-35150
	FILTRO COMBUSTIBLE	FUEL FILTER	FILTRO COMBUSTIBILE	REC41650-550800
	IMPULSOR	IMPELLER	GIRANTE	REC21213660
	FILTRO AIRE	AIR FILTER	FILTRO ARIA	REC129470-12330
	TERMOSTATO	THERMOSTAT	TERMOSTATO	REC129470-49801
	CORREA ALTERNADOR	ALTERNATOR BELT	CINGHIA ALTERNATORE	REC25132-004500
2GMSZK	FILTRO ACEITE	OIL FILTER	FILTRO OLIO	REC119305-35151
	FILTRO COMBUSTIBLE	FUEL FILTER	FILTRO COMBUSTIBILE	REC121750-55701
	FILTRO AIRE	AIR FILTER	FILTRO ARIA	REC128270-12540
	IMPULSOR	IMPELLER	GIRANTE	REC3586494
	TERMOSTATO	THERMOSTAT	TERMOSTATO	REC105582-49200
	CORREA ALTERNADOR	ALTERNATOR BELT	CINGHIA ALTERNATORE	REC25132-003000
	CORREA BOMBA	PUMP BELT	CINGHIA POMPA	REC128695-42780
ÁNODO	ANODE	ANODO	CMC272100-20030	
4LHA-DTE, -DTP, -DTZE, -DTZP, -HTE, -HTP, -HTZE, -HTZP, -STE, -STP, -STZE	FILTRO ACEITE	OIL FILTER	FILTRO OLIO	REC127695-35150
	FILTRO COMBUSTIBLE	FUEL FILTER	FILTRO COMBUSTIBILE	REC41650-502320
	FILTRO AIRE	AIR FILTER	FILTRO ARIA	REC119195-18880
	IMPULSOR	IMPELLER	GIRANTE	REC3841697
	TERMOSTATO	THERMOSTAT	TERMOSTATO	REC121850-49811
	CORREA ALTERNADOR	ALTERNATOR BELT	CINGHIA ALTERNATORE	REC121850-42280
	ÁNODO	ANODE	ANODO	TEN01316
4LHA-STZP	FILTRO ACEITE	OIL FILTER	FILTRO OLIO	REC127695-35150
	FILTRO COMBUSTIBLE	FUEL FILTER	FILTRO COMBUSTIBILE	REC41650-502320
	FILTRO AIRE	AIR FILTER	FILTRO ARIA	REC119195-18880
	IMPULSOR	IMPELLER	GIRANTE	REC3841697
	TERMOSTATO	THERMOSTAT	TERMOSTATO	REC121850-49811
	CORREA ALTERNADOR	ALTERNATOR BELT	CINGHIA ALTERNATORE	REC121850-42280
	ÁNODO	ANODE	ANODO	TEN01317
4LH-DTE, -DTZ, -HT	FILTRO ACEITE	OIL FILTER	FILTRO OLIO	REC127695-35150
	FILTRO COMBUSTIBLE	FUEL FILTER	FILTRO COMBUSTIBILE	REC41650-502320
	FILTRO AIRE	AIR FILTER	FILTRO ARIA	RECXN199611
	IMPULSOR	IMPELLER	GIRANTE	REC3841697
	TERMOSTATO	THERMOSTAT	TERMOSTATO	REC121850-49811
	CORREA ALTERNADOR	ALTERNATOR BELT	CINGHIA ALTERNATORE	REC121850-42280
	ÁNODO	ANODE	ANODO	TEN01317
4LH-HTE	FILTRO ACEITE	OIL FILTER	FILTRO OLIO	REC119005-35100
	FILTRO COMBUSTIBLE	FUEL FILTER	FILTRO COMBUSTIBILE	REC121857-55710
	FILTRO AIRE	AIR FILTER	FILTRO ARIA	RECXN199611
	IMPULSOR	IMPELLER	GIRANTE	REC3841697
	TERMOSTATO	THERMOSTAT	TERMOSTATO	REC121850-49811
	CORREA ALTERNADOR	ALTERNATOR BELT	CINGHIA ALTERNATORE	REC121850-42280
	ÁNODO	ANODE	ANODO	TEN01317
4LH-HTZ, -HTZAY, STE	FILTRO ACEITE	OIL FILTER	FILTRO OLIO	REC127695-35150
	FILTRO COMBUSTIBLE	FUEL FILTER	FILTRO COMBUSTIBILE	REC41650-502320
	FILTRO AIRE	AIR FILTER	FILTRO ARIA	RECXN199611
	IMPULSOR	IMPELLER	GIRANTE	REC3841697
	TERMOSTATO	THERMOSTAT	TERMOSTATO	REC121850-49811
	CORREA ALTERNADOR	ALTERNATOR BELT	CINGHIA ALTERNATORE	REC121850-42280
	ÁNODO	ANODE	ANODO	TEN01317
4LH-ST, -STZ, -STZAY	FILTRO ACEITE	OIL FILTER	FILTRO OLIO	REC127695-35150
	FILTRO COMBUSTIBLE	FUEL FILTER	FILTRO COMBUSTIBILE	REC41650-502320
	IMPULSOR	IMPELLER	GIRANTE	REC3841697
	TERMOSTATO	THERMOSTAT	TERMOSTATO	REC121850-49811
	CORREA ALTERNADOR	ALTERNATOR BELT	CINGHIA ALTERNATORE	REC121850-42280
	ÁNODO	ANODE	ANODO	TEN01317
	4LH-TE	FILTRO ACEITE	OIL FILTER	FILTRO OLIO
FILTRO COMBUSTIBLE		FUEL FILTER	FILTRO COMBUSTIBILE	REC121857-55710
FILTRO AIRE		AIR FILTER	FILTRO ARIA	RECXN199611
IMPULSOR		IMPELLER	GIRANTE	REC3841697
TERMOSTATO		THERMOSTAT	TERMOSTATO	REC121850-49811
CORREA ALTERNADOR		ALTERNATOR BELT	CINGHIA ALTERNATORE	REC121850-42280
ÁNODO		ANODE	ANODO	TEN01317
4LH-UT, -UTZ, -UTZAY	FILTRO ACEITE	OIL FILTER	FILTRO OLIO	REC127695-35150
	FILTRO COMBUSTIBLE	FUEL FILTER	FILTRO COMBUSTIBILE	REC41650-502320
	IMPULSOR	IMPELLER	GIRANTE	REC3841697
	CORREA ALTERNADOR	ALTERNATOR BELT	CINGHIA ALTERNATORE	REC121850-42280
	ÁNODO	ANODE	ANODO	TEN01317
4LH-WST, -WSTZY	FILTRO ACEITE	OIL FILTER	FILTRO OLIO	REC127695-35150
	CORREA ALTERNADOR	ALTERNATOR BELT	CINGHIA ALTERNATORE	REC121850-42280
6BY	FILTRO ACEITE	OIL FILTER	FILTRO OLIO	REC165000-69590
	FILTRO COMBUSTIBLE	FUEL FILTER	FILTRO COMBUSTIBILE	REC120650-55040
6CX-ETE	FILTRO ACEITE	OIL FILTER	FILTRO OLIO	REC127695-35150
	FILTRO COMBUSTIBLE	FUEL FILTER	FILTRO COMBUSTIBILE	REC127695-55630
	FILTRO AIRE	AIR FILTER	FILTRO ARIA	REC119593-18880
	IMPULSOR	IMPELLER	GIRANTE	REC128620-42201
	TERMOSTATO	THERMOSTAT	TERMOSTATO	REC123682-48601
	CORREA ALTERNADOR	ALTERNATOR BELT	CINGHIA ALTERNATORE	REC25132-004250 (2)
6CX-GT	FILTRO ACEITE	OIL FILTER	FILTRO OLIO	REC127695-35150
	FILTRO COMBUSTIBLE	FUEL FILTER	FILTRO COMBUSTIBILE	REC127695-55630
	FILTRO AIRE	AIR FILTER	FILTRO ARIA	REC119593-18880
	IMPULSOR	IMPELLER	GIRANTE	REC128620-42201
	TERMOSTATO	THERMOSTAT	TERMOSTATO	REC145640-48410
	CORREA ALTERNADOR	ALTERNATOR BELT	CINGHIA ALTERNATORE	REC25132-004250 (2)
ÁNODO	ANODE	ANODO	TEN01312	

Modelo Model Modello	DESCRIPCIÓN	DESCRIPTION	DESCRIZIONE	Ref.
6CXM-ETE	FILTRO ACEITE	OIL FILTER	FILTRO OLIO	REC127695-35150
	FILTRO COMBUSTIBLE	FUEL FILTER	FILTRO COMBUSTIBILE	REC127695-55630
	FILTRO AIRE	AIR FILTER	FILTRO ARIA	REC119593-18880
	IMPULSOR	IMPELLER	GIRANTE	REC128620-42201
	TERMOSTATO	THERMOSTAT	TERMOSTATO	REC123682-48601
	CORREA ALTERNADOR	ALTERNATOR BELT	CINGHIA ALTERNATORE	REC25132-004250 (2)
6GHA-ET	FILTRO ACEITE	OIL FILTER	FILTRO OLIO	REC128633-35400
	FILTRO COMBUSTIBLE	FUEL FILTER	FILTRO COMBUSTIBILE	REC41650-501140
	IMPULSOR	IMPELLER	GIRANTE	REC128628-42200
	TERMOSTATO	THERMOSTAT	TERMOSTATO	REC145640-48410
	CORREA ALTERNADOR	ALTERNATOR BELT	CINGHIA ALTERNATORE	REC128610-77350 (2)
	ÁNODO	ANODE	ANODO	TEN01303 TEN01301 TEN01311 TEN01312
6GHA-ST, STE 6GHAK-ST1 6GHAM-STE 6GHD-ST	FILTRO ACEITE	OIL FILTER	FILTRO OLIO	REC126650-35220
	FILTRO COMBUSTIBLE	FUEL FILTER	FILTRO COMBUSTIBILE	REC41650-501140
	IMPULSOR	IMPELLER	GIRANTE	REC128628-42200
	TERMOSTATO	THERMOSTAT	TERMOSTATO	REC145640-48410
	CORREA ALTERNADOR	ALTERNATOR BELT	CINGHIA ALTERNATORE	REC128610-77350 (2)
	ÁNODO	ANODE	ANODO	TEN01303 TEN01301 TEN01311 TEN01312
6KHL-ST	FILTRO ACEITE	OIL FILTER	FILTRO OLIO	REC124626-35420
	FILTRO COMBUSTIBLE	FUEL FILTER	FILTRO COMBUSTIBILE	REC41650-502330
	IMPULSOR	IMPELLER	GIRANTE	REC126630-42030
	TERMOSTATO	THERMOSTAT	TERMOSTATO	REC145640-48410
	CORREA ALTERNADOR	ALTERNATOR BELT	CINGHIA ALTERNATORE	REC126634-11340
	ÁNODO	ANODE	ANODO	TEN01303 TEN01301 TEN01311
6LPA-DTP, -DTZP, -STP, -STZ 6LP-DT, -DTE, -DTZE, -DTZY, -ST, -STE, -STZE, -STZY, -WDT, -WDTZY	FILTRO ACEITE	OIL FILTER	FILTRO OLIO	REC119770-90620
	FILTRO COMBUSTIBLE	FUEL FILTER	FILTRO COMBUSTIBILE	REC119773-55510
	FILTRO AIRE	AIR FILTER	FILTRO ARIA	REC119593-18880
	IMPULSOR	IMPELLER	GIRANTE	REC13554-0001
	TERMOSTATO	THERMOSTAT	TERMOSTATO	REC119773-49550
	CORREA ALTERNADOR	ALTERNATOR BELT	CINGHIA ALTERNATORE	REC119773-77251 (2)
ÁNODO	ANODE	ANODO	TEN01317T	
6LY2-ST	FILTRO ACEITE	OIL FILTER	FILTRO OLIO	REC119593-35100 (1) REC119593-35400 (1)
	FILTRO COMBUSTIBLE	FUEL FILTER	FILTRO COMBUSTIBILE	REC127695-55630 (2)
	FILTRO AIRE	AIR FILTER	FILTRO ARIA	REC119195-18880
	IMPULSOR	IMPELLER	GIRANTE	CEF500162G
	TERMOSTATO	THERMOSTAT	TERMOSTATO	REC127605-48590
	CORREA ALTERNADOR	ALTERNATOR BELT	CINGHIA ALTERNATORE	REC119593-42300
ÁNODO	ANODE	ANODO	TEN01317T	
6LY2-STE	FILTRO ACEITE	OIL FILTER	FILTRO OLIO	REC119593-35100 (1) REC119593-35400 (1)
	FILTRO COMBUSTIBLE	FUEL FILTER	FILTRO COMBUSTIBILE	REC127695-55630 (2)
	FILTRO AIRE	AIR FILTER	FILTRO ARIA	REC119195-18880
	IMPULSOR	IMPELLER	GIRANTE	CEF500162G
	TERMOSTATO	THERMOSTAT	TERMOSTATO	REC127605-48590
	CORREA ALTERNADOR	ALTERNATOR BELT	CINGHIA ALTERNATORE	REC119593-42300
6LY2-STVY	FILTRO ACEITE	OIL FILTER	FILTRO OLIO	REC119593-35100 (1) REC119593-35400 (1)
	FILTRO COMBUSTIBLE	FUEL FILTER	FILTRO COMBUSTIBILE	REC127695-55630 (2)
	TERMOSTATO	THERMOSTAT	TERMOSTATO	REC127605-48590
	ÁNODO	ANODE	ANODO	TEN01317T
6LY2-STP	FILTRO ACEITE	OIL FILTER	FILTRO OLIO	REC119593-35100 (1) REC119593-35400 (1)
	IMPULSOR	IMPELLER	GIRANTE	REC47-809866T
	ÁNODO	ANODE	ANODO	TEN01317T
6LY2-STVY 6LY2A-STE, -UTP 6LY2M-WDT, -WST	FILTRO ACEITE	OIL FILTER	FILTRO OLIO	REC119593-35100 (1) REC119593-35400 (1)
	ÁNODO	ANODE	ANODO	TEN01317T
	FILTRO ACEITE	OIL FILTER	FILTRO OLIO	REC119593-35100 (1) REC119593-35400 (1)
6LY2-WDT, -WDTZY, -WST	FILTRO COMBUSTIBLE	FUEL FILTER	FILTRO COMBUSTIBILE	REC127695-55630 (2)
	ÁNODO	ANODE	ANODO	TEN01317T
	FILTRO ACEITE	OIL FILTER	FILTRO OLIO	REC119593-35100 (1) REC119593-35400 (1)
	FILTRO COMBUSTIBLE	FUEL FILTER	FILTRO COMBUSTIBILE	REC127695-55630
	FILTRO AIRE	AIR FILTER	FILTRO ARIA	REC119195-18880
	IMPULSOR	IMPELLER	GIRANTE	REC19574-42550
TERMOSTATO	THERMOSTAT	TERMOSTATO	REC127605-48590	
ÁNODO	ANODE	ANODO	TEN01317T	
6LY2A-STP	FILTRO ACEITE	OIL FILTER	FILTRO OLIO	REC119593-35100 REC119593-35400 (1)
	FILTRO COMBUSTIBLE	FUEL FILTER	FILTRO COMBUSTIBILE	REC127695-55630
	FILTRO AIRE	AIR FILTER	FILTRO ARIA	REC119195-18880
	IMPULSOR	IMPELLER	GIRANTE	REC19574-42550
	TERMOSTATO	THERMOSTAT	TERMOSTATO	REC127605-48590
	ÁNODO	ANODE	ANODO	TEN01317T
6LY3-ETP, -STP, -UTP	FILTRO ACEITE	OIL FILTER	FILTRO OLIO	REC119593-35100
	FILTRO COMBUSTIBLE	FUEL FILTER	FILTRO COMBUSTIBILE	REC41650-502330
	FILTRO AIRE	AIR FILTER	FILTRO ARIA	REC119195-18880
	IMPULSOR	IMPELLER	GIRANTE	REC19574-42550
	CORREA ALTERNADOR	ALTERNATOR BELT	CINGHIA ALTERNATORE	REC119593-42300
	ÁNODO	ANODE	ANODO	CMC272100-20030
6LYA-STE	FILTRO ACEITE	OIL FILTER	FILTRO OLIO	REC119593-35100
	FILTRO COMBUSTIBLE	FUEL FILTER	FILTRO COMBUSTIBILE	REC41650-502330
	FILTRO AIRE	AIR FILTER	FILTRO ARIA	REC119195-18880
	IMPULSOR	IMPELLER	GIRANTE	REC19574-42550
	ÁNODO	ANODE	ANODO	TEN01316

# ÍNDICE / TABLE OF CONTENTS / INDICE

REF-->R.O. / OEM

REF.	R.O. /OEM	PAG	REF.	R.O. /OEM	PAG	REF.	R.O. /OEM	PAG
CEF500100GX		602	REC105225-11110	105225-11110	600	REC119773-42502	119773-42652	602
CEF500113	128176-42080	592	REC105582-49200	105582-49200	603	REC119773-49550	119773-49550	604-620
CEF500161	119593-42200	593	REC105582-49200	124223-49250	603	REC119773-55510	119773-55510	604-620
CEF500161	119593-42201	593	REC105582-49200	181130-49200	603	REC119773-77251		620
CEF500162G	119574-42550	593	REC105582-49200		616-617-618-619	REC119773-77260	119773-77250	611
CEF500162G	119574-42552	593	REC105582-82041	105582-82041	592	REC119775-77260	119775-77260	611
CEF500162G		602-620	REC119000-01771	119000-01771	591	REC119802-55810	119802-55810	605
CM19642002652A	196420-02652	612	REC119000-32020	119000-32020	607	REC120130-91370	120130-91370	607
CM19642002652A	196450-02492	612	REC119000-42021	119000-42021	603	REC120324-55760	120324-55760	605
CM19642002652Z	196420-02652	612	REC119005-35100	109005-35170	606	REC120650-55040		619
CM19642002652Z	196450-02492	612	REC119005-35100	119005-35100	606	REC121000-01751	121000-01750	590
CM19644002660KITA	196440-02660	612	REC119005-35100	119005-35151	606	REC121000-01751	121000-01751	590
CM19644002660KITA	196450-02501	612	REC119005-35100		619	REC121000-03071	121000-03070	591
CM19644002660KITZ	196440-02660	612	REC119100-11360	119100-11360	589	REC121000-03071	121000-03071	591
CM19644002660KITZ	196450-02501	612	REC119100-12113	119100-12113	589	REC121000-42052	121000-42050	603
CMC272100-20030		618	REC119171-11110	119171-11110	600	REC121000-42052	121000-42051	603
CMC10421141-300	104211-41300	612	REC119171-11150	119171-11150	600	REC121000-42052	121000-42052	603
CMC272100-20030	27210-200300	612-616-617-618-619-620	REC119171-13510	119171-13510	590	REC121254-77012	121254-77010	610
GS38107	128270-08341	612	REC119171-18010	119171-18010	608	REC121254-77012	121254-77011	610
GS38108	124772-08341	612	REC119172-18011	119172-18011	609	REC121254-77012	121254-77012	610
GS38120	124770-12540	612	REC119172-18030	119172-18030	609	REC121254-77012	121254-77019	610
GS38121	121370-08351	612	REC119173-11101	119173-11101	600	REC121254-77012	129429-77010	610
HGE3520	104070-13520	601	REC119173-18011	119173-18011	608	REC121254-77012	129429-77011	610
HGE3520	104214-13521	601	REC119173-18041	119173-18041	608	REC121400-11340	121400-11340	600
HGE3520	104214-13531	601	REC119174-01340	119174-01340	585	REC121400-11810	121400-11810	595
HGE3520	127070-13520	601	REC119174-13201	119174-13201	590	REC121450-02100	121450-02100	598
HGE3520	128370-13600	601	REC119175-18031	119175-18031	609	REC121450-02110	121450-02110	598
HGE3520	128990-13520	601	REC119195-18031	119195-18031	608	REC121450-02160	121450-02160	599
MAR13200	724770-13200	601	REC119195-18880	119195-18880	607-619-620	REC121450-02170	121450-02170	598
MAR13552	129579-13551	601	REC119305-35151	119305-35151	605-616-617-619	REC121450-11310	121450-11310	589
MAR13552	129671-13551	601	REC119305-35160		617-618	REC121450-11681	121450-11680	591
MAR13552	129792-13550	601	REC119305-35170		616	REC121450-11681	121450-11681	591
MAR13552	129792-13551	601	REC119574-42502	119574-42500	602	REC121450-32021	121450-32021	606
MAR13552	129792-13552	601	REC119574-42502	119574-42501	602	REC121450-44411	121450-44410	604
MAR13561	129470-13560	601	REC119574-42502	119574-42502	602	REC121450-44411	121450-44411	604
MAR13561	129470-13561	601	REC119574-42550	119574-42550	593	REC121520-01851	121520-01850	591
PH140-0007	114361-77011	610	REC119574-42550		593	REC121520-01851	121520-01851	591
PH140-0007	114362-77010	610	REC119578-42501	119578-42500	602	REC121575-01334	121575-01331	584
PH140-0007	114362-77011	610	REC119578-42501	119578-42501	602	REC121575-01334	121575-01332	584
PH140-0007	114399-77010	610	REC119593-11110	119593-11110	600	REC121575-01334	121575-01333	584
PH140-0008	128170-77010	610	REC119593-18880	119593-18880	607-619-620	REC121575-01334	121575-01334	584
PH140-0008	128170-77010D	610	REC119593-22351	119593-22351	597	REC121575-01510	121575-01510	592
PH140-0009	121370-77010	610	REC119593-35100	119593-35100	606-620	REC121575-01510	121575-01511	592
PH140-0009	129242-77010	610	REC119593-35400	119593-35400	606	REC121575-01512	121575-01512	592
PH140-0009	129608-77010	610	REC119593-42280	119593-42280	611	REC121575-01861	121575-01861	591
PH140-0009	129698-77010	610	REC119593-42300		620	REC121750-49800	121750-49800	603-616-617-618
PH150-0004	121256-77011	610	REC119593-42350	119593-42350	611	REC121750-55701		616-619
PH150-0004	124250-77012	610	REC119593-49550	119593-49550	604	REC121850-01800	121850-01800	595
PH150-0004	124450-77011	610	REC119595-01350	119595-01350	585	REC121850-11100	121850-11100	600
PH150-0004	124772-77010	610	REC119595-01800	119595-01800	596	REC121850-11150	121850-11150	599-600
PH150-0004	124772-77020	610	REC119595-22300	119595-22300	597	REC121850-42280E		619
PH150-0004	129573-77010	610	REC119609-32040	119609-32040	594	REC121850-42280E	121850-42280E	611
PH150-0004	171006-77010	610	REC119717-02930	119717-02930	599	REC121850-49811	121850-49811	604-619
PH150-0004	171008-77010	610	REC119717-11340	119717-11340	600	REC121850-51960	121850-51960	594
PH150-0005	119773-77010	610	REC119717-11350	119717-11350	600	REC121857-55710	121857-55710	605-619
PH300-0002	119573-77200	611	REC119770-00060	119770-00060	589	REC122710-01781	122710-01781	595
PH300-0002	119573-77201	611	REC119770-00130	119770-00130	599	REC123500-77010	123500-77010	610
PH300-0002	129470-77200	611	REC119770-00250	119770-00250	597	REC123500-77010	124610-77010	610
PH300-0002	129772-77200	611	REC119770-00260	119770-00260	598	REC123500-77010	124610-77019	610
PH300-0005	128171-77200	611	REC119770-00480	119770-00480	600	REC123500-77010	424610-77010	610
PH300-0005	128270-77200	611	REC119770-00490	119770-00490	600	REC123672-01782	123672-01782	596
PH300-0005	128270-77201	611	REC119770-00930	119770-00930	585	REC123672-77370		617
PH300-0005	128270-77202	611	REC119770-00940	119770-00940	586	REC123682-48601		618-619-620
PH300-0018	119773-77200	611	REC119770-00950	119770-00950	586	REC124000-01751	124000-01750	590
PH300-0018	119773-77201	611	REC119770-01010	119770-01010	598	REC124000-01751	124000-01751	590
PH300-0020	119612-77230	611	REC119770-01020	119770-01020	598	REC124085-02220	124085-02220	596
PH300-0020	119836-77200	611	REC119770-01030	119770-01030	598	REC124160-34845	124160-34844	591
PH300-0020	119836-77201	611	REC119770-01040	119770-01040	598	REC124160-34845	124160-34845	591
PH300-0020	129930-77211	611	REC119770-02031	119770-02031	598	REC124223-42110	124223-42110	603
REC040122		588	REC119770-90090	119770-90090	596	REC124240-01883	124240-01882	591
REC104211-11100	104211-11100	600	REC119770-90290	119770-90290	596	REC124240-01883	124240-01883	591
REC104211-11110	104211-11110	600	REC119770-90620	119770-90620	606-620	REC124411-01780	124411-01780	596
REC104211-42090	104211-42090	591-603	REC119770-91030	119770-91030	599	REC124460-11340	124460-11340	600
REC104211-49160	104211-49160	604	REC119771-00040	119771-00040	589	REC124550-35110	124085-35113	606
REC104211-77011	104211-77010	610	REC119771-00401	119771-00401	585	REC124550-35110	124550-35110	606-617-618
REC104211-77011	104211-77011	610	REC119771-00411	119771-00411	586	REC124610-01862	124610-01861	591
REC104500-55710	104500-55710	605-616-617-618	REC119771-00421	119771-00421	586	REC124610-01862	124610-01862	591
REC104511-11100	104511-11100	600	REC119773-42502	10-24493-01	602	REC124626-35420		620
REC104511-78780	104511-78780	602-616-617-618	REC119773-42502	119773-42501	602	REC124722-42290		618
REC104511-78780E	104511-78780E	611	REC119773-42502	119773-42502	602	REC124732-42290		616
REC105225-02020	105225-02020	594	REC119773-42502	119773-42502	602	REC124770-12540	124770-12540	607
REC105225-02040	105225-02040	592	REC119773-42502	119773-42650	602	REC124950-11340	124950-11340	599
REC105225-11100	105225-11100	600	REC119773-42502	119773-42651	602			

REF.	R.O./OEM	PAG	REF.	R.O./OEM	PAG	REF.	R.O./OEM	PAG
REC126630-42030		620	REC129150-35153	129150-35153	606	REC24321-000350	24321-000350	594
REC126634-11340		620	REC129150-35153	129150-35170	606	REC24321-000350	24325-000350	594
REC126650-35220		620	REC129150-35153		617-618	REC24341-000240	24341-000240	594
REC126650-35350	126650-35350	605	REC129150-35170		618	REC25111-002100		618
REC127605-48590	127605-48590	604	REC129150-77511	129150-77511	589	REC25117-003151		616
REC127605-48590		620	REC129171-01330	129171-01330	584	REC25132-002700	25132-002700	611
REC127610-22501	127610-22501	597	REC129198-01750	129198-01750	590	REC25132-003000		616-619
REC127610-42200		618	REC129271-42502	129271-42500	602	REC25132-003100	25132-003100	611-616
REC127610-91350	127610-91350	607	REC129271-42502	129271-42501	602	REC25132-003700	25132-003700	611-616-617
REC127616-11280	127616-11280	599	REC129271-42502	129271-42502	602	REC25132-004250	25132-004250	611-619-620
REC127692-18880	127692-18880	607	REC129350-49541	129350-49540	604	REC25132-004500	25132-004500	611-617-618-619
REC127695-35150	127695-35150	606	REC129350-49541	129350-49541	604	REC25132-004600	25132-004600	611-618
REC127695-35150	127695-35160	606	REC129400-01751	129400-01750	591	REC251321-003000	251321-003000	611
REC127695-55630	127695-55630	604-605-619-620	REC129400-01751	129400-01751	591	REC25152-004300	25152-004300	611-618
REC128170-01331	128170-01331	584	REC129407-01340	129407-01340	585	REC3586494	104211-42070	592
REC128170-01510	128170-01510	592	REC129408-01330	129408-01330	585	REC3586494	104211-42071	592
REC128170-01510	128170-01511	592	REC129470-01550	129470-01550	594	REC3586494		616-619
REC128170-01751	128170-01750	590	REC129470-12130	129470-12130	589	REC3841697	120650-42310	592
REC128170-01751	128170-01751	590	REC129470-12330	129470-12330	607-617-618-619	REC3841697	127610-42200	592
REC128170-03070	128170-03070	591	REC129470-35040	129470-35040	606	REC3841697		619
REC128170-11310	128170-11310	589	REC129470-35121	129470-35121	607	REC41650-501140	41650-501140	605-620
REC128170-12540	128170-12540	607-616	REC129470-42531		618	REC41650-502320	41650-502320	605-619
REC128170-13201	128170-13201	590	REC129470-49801	129470-49801	603-617-618-619	REC41650-502330	41650-502330	605-620
REC128170-32030	128170-32030	606	REC129470-55701		617	REC41650-550800		618-619
REC128170-42070		616	REC129470-55703	129470-55703	605-617-618	REC41650-550810		618
REC128170-42090	128170-42090	603	REC129472-18090	129472-18090	590	REC43400-500390	43400-500390	595
REC128170-77350	128170-77350	611-616	REC129473-18000	129473-18000	609	REC43400-500450	43400-500450	595
REC128171-01911	128171-01330	584	REC129486-42050	129486-42050	603	REC47-809866T		620
REC128171-01911	128171-01911	584	REC129486-42050	129150-42020	603	REC653-0001	128990-42200	592
REC128171-12540		616	REC129497-18000	129497-18000	609	REC653-0001	128990-42570	592
REC105225-0240	128270-11310	589	REC129550-13110	129550-13110	590	REC653-0001		602-616-617
REC128270-12540	128270-12540	607-616-617-618-619	REC129553-01350	129553-01350	585	REC704571-22500	704571-22500	597
REC128271-01911	128271-01911	584	REC129573-01351	129573-1351	585	REC705311-23600	705311-23600	598
REC128275-91340	128275-91340	607	REC129574-55711	129574-55711	605-618	REC719000-02800	719000-02800	597
REC128300-13230	128300-13230	590	REC129590-22510	129590-22510	597	REC719000-02930	719000-02930	599
REC128370-01332	128370-01332	584	REC129601-11310	129601-11310	589	REC719000-22501	719000-22501	597
REC128370-01332	128370-01332	584	REC129612-42290		617	REC719171-92602	719171-92602	585-588
REC128370-13181	128370-13181	590	REC129612-42290E	129612-42290E	611	REC719173-92600	719173-92600	585-588
REC128374-01911	128374-01911	584	REC129670-42513	129670-42500	602	REC719174-23601	719174-23601	598
REC128397-42500	10-13328-03	602	REC129670-42513	129670-42501	602	REC719593-02590	719593-02590	599
REC128397-42500	121575-42200	602	REC129670-42513	129670-42502	602	REC719593-02800	729593-02800	598
REC128397-42500	128377-42500	602	REC129670-42513	129670-42512	602	REC719593-23601	719593-23601	598
REC128397-42500	128397-42500	602	REC129670-42513	129670-42513	602	REC719595-23600	719595-23600	598
REC128397-42500	128990-42510	602	REC129670-42513	429670-42510	602	REC719717-02901	719717-02901	597
REC128610-01650	128610-01650	596	REC129670-42513	429670-42511	602	REC721000-22500	721000-22500	596
REC128610-02131	128610-02131	598	REC129670-42531		618	REC721575-22500	705311-22500	596
REC128610-02250	128610-02250	599	REC129671-18001	129671-18001	608	REC721575-22500	721575-22500	596
REC128610-77350		620	REC129673-77680		618	REC728170-92600	728170-92600	584-586
REC128619-11100	128619-11100	600	REC129690-02800	129690-02800	597	REC728171-92601	728171-92601	584-586
REC128619-11110	128619-11110	600	REC129693-01331	129693-01331	585	REC728176-92600	728176-92600	586
REC128620-42201		619-620	REC129795-01800	129795-01800	595	REC728270-42002	128270-42000	602
REC128625-01342	128625-01342	585	REC129795-49551	129795-49551	604	REC728270-42002	128270-42001	602
REC128625-23361	128625-23361	598	REC129940-42310E	129940-42310E	611	REC728270-42002	128270-42002	602
REC128628-42200		620	REC13554-0001	119773-42600	593	REC728271-92605	728271-92605	584-586
REC128628-42203	128628-42203	593	REC13554-0001	119773-42601	593	REC728277-92606	728277-92606	586
REC128633-35400	128633-35400	606-620	REC13554-0001		602-620	REC728370-92605	728370-92605	587
REC128670-77350	128670-77350	611-617	REC1411-0001	128176-42080	592	REC728370-92605	728370-92605	587
REC128671-01330	128671-01330	584	REC145640-48410	145640-48410	604-619-620	REC728374-92605	728374-92605	584
REC128695-42780		616-619	REC165000-69590		619	REC728374-92605	728374-92605	584-587
REC128695-44780		617-618	REC165000-69950	165000-69950	604	REC728623-92601	728623-92601	585-588
REC128990-42200		618	REC171087-42280		617	REC728633-22500	728633-22500	597
REC128990-49800	128990-49800	603-617	REC19574-42550		620	REC728670-92600	728670-92600	587
REC128990-77350		617	REC119593-11380	119593-11380	589	REC728670-92602	728670-92601	587
REC128991-12500		617	REC21213660	129470-42352	593	REC728670-92602	978670-92602	587
REC128991-42200		617	REC21213660	129470-42530	593	REC728670-92602		584
REC129001-01340	129001-01340	584	REC21213660	129670-42530	593	REC729120-22500	729120-22500	596
REC129001-02931	129001-02931	598	REC21213660	129670-42531	593	REC729171-92600	729171-92600	584-587
REC129002-01331	129002-01331	584	REC21213660		602-617-618-619	REC729270-92601	729270-92601	584-587
REC129005-11100	129005-11100	600	REC22190-060002	22190-060002	594	REC729271-92600	729271-92600	584-587
REC129005-22500	129005-22500	596	REC22190-080002	22190-080002	594	REC729407-92605	729407-92600	588
REC129100-01621	129100-01621	592	REC22190-100002	22190-100002	595	REC729407-92605	729407-92605	588
REC129100-11100	129100-11100	600	REC22190-120002	22190-120002	595	REC729407-92605		585
REC129100-11112	129100-11112	600	REC22190-140002	22190-140002	595	REC729408-92605	729408-92600	588
REC129120-11100	129120-11100	600	REC22190-240002	22190-240002	595	REC729408-92605	729408-92605	588
REC129120-11110	129120-11110	600	REC22779-0001	124223-42091	592	REC729408-92605		585
REC129120-35121	129120-35121	606	REC22779-0001	124223-42092	592	REC729470-92605	729470-92605	585-588
REC129150-01511	129150-01511	592	REC22779-0001	128296-42070	592	REC729573-92605	729573-92605	585-587
REC129150-01531	129150-01531	592	REC22779-0001	128620-42200	592	REC729693-92600		585-588
REC129150-01881	129150-01881	603	REC22779-0001		616-617-618	REC930122		588
REC129150-02800	129150-02800	597	REC23414-080000	23414-080000	593	RECN199611	XN199611	607-619
REC129150-02931	129150-02931	599	REC23414-100000	23414-100000	593	SED3092400	119173-13501	601
REC129150-12111	129150-12111	589	REC23414-120000	23414-120000	593	SED3092401	119181-13500	601
REC129150-13110	129150-13110	590	REC23414-250000	23414-250000	593	SED3092500	119773-13501	601
REC129150-23601	129150-23601	598	REC24311-000100	24311-000100	594	SED3092500	119773-13500	601
REC129150-35042	129150-35042	606	REC24311-000120	24311-000120	594	SOL1651-140-27		615
REC129150-35111	129150-35111	603	REC24311-000160	24311-000160	594	SOL1651-138-28		615
REC129150-35150		618-619	REC24311-000320	24311-000320	594	SOL1651-140-24		615
REC129150-35151		617	REC24311-000700	24311-000700	594	SOL1651-140-25		615

REF.	R.O./OEM	PAG	REF.	R.O./OEM	PAG	REF.	R.O./OEM	PAG
SOL1651-140-26		615	SOL8812-148-17		615	TENO1316T	119574-44150	614
SOL1651-143-22		615	SOL8812-150-15		615	TENO1316TP		614
SOL1651-143-23		615	SOL8812-153-19		615	TENO1317	177301-54900	614-619
SOL1651-144-20		615	SOL8812-153-21		615	TENO1317T	119574-18790	614-620
SOL1651-144-21		615	SOL8812-155-17		615	TENO1317TP		614
SOL1654-150-27		615	SOL8812-158-15		615	TENO1318	27210-200370	614
SOL1654-150-28		615	TENO1300	104211-41300	613	TENO1318T	119574-44150	614
SOL1654-155-24		615	TENO1301	27210-200300	613-620	TENO1318TP		614
SOL1654-155-25		615	TENO1302		613	TENO1319	196640-62680	614
SOL1654-155-26		615	TENO1303	27210-200200	613-616-620	TENO1390-1	196350-02550	613
SOL1654-158-22		615	TENO1304	196630-02670	613	TENO1391-1	196350-02570	613
SOL1654-158-23		615	TENO1305/1	196440-02660	613	TENO1392-1	196350-09910	614
SOL1654-160-20		615	TENO1305/1	196450-02501	613	TENO1393-1	196350-07360	613
SOL1654-160-21		615	TENO1306	177301-549000	613	TENO1394-1	196350-02350	614
SOL8712-143-21		615	TENO1306	27210-200550	613	TENPLAC-1	196440-02690	613
SOL8712-148-17		615	TENO1308	104211-41300	613			
SOL8712-150-15		615	TENO1310	27200-400400	613			
SOL8812-142-23		615	TENO1311	27200-300400	613-620			
SOL8812-143-21		615	TENO1312	27210-200370	613-619-620			
SOL8812-145-19		615	TENO1316	27210-200370	614-619-620			

R.O. / OEM --> REF

R.O./OEM	REF	PAG	R.O./OEM	REF	PAG	R.O./OEM	REF	PAG
10-13328-03	REC128397-42500	602	119574-44150	TENO1316T	614	120650-42310	REC3841697	592
10-24493-01	REC119773-42502	602	119574-44150	TENO1318T	614	121000-01750	REC121000-01751	590
104070-13520	HGE3520	601	119578-42500	REC119578-42501	602	121000-01751	REC121000-01751	590
104211-11100	REC104211-11100	600	119578-42501	REC119578-42501	602	121000-03070	REC121000-03071	591
104211-11110	REC104211-11110	600	119593-11110	REC119593-11110	600	121000-03071	REC121000-03071	591
104211-41300	CMC10421141-300	612	119593-18880	REC119593-18880	607-619-620	121000-42050	REC121000-42052	603
104211-41300	TENO1300	613	119593-22351	REC119593-22351	597	121000-42051	REC121000-42052	603
104211-41300	TENO1308	613	119593-35100	REC119593-35100	606-620	121000-42052	REC121000-42052	603
104211-42070	REC3586494	592	119593-35400	REC119593-35400	606	121254-77010	REC121254-77012	610
104211-42071	REC3586494	592	119593-42200	CEF500161	593	121254-77011	REC121254-77012	610
104211-42090	REC104211-42090	591-603	119593-42201	CEF500161	593	121254-77012	REC121254-77012	610
104211-49160	REC104211-49160	604	119593-42280	REC119593-42280	611	121254-77019	REC121254-77012	610
104211-77010	REC104211-77011	610	119593-42350	REC119593-42350	611	121256-77011	PH150-0004	610
104211-77011	REC104211-77011	610	119593-49550	REC119593-49550	604	121370-08351	GS38121	612
104214-13521	HGE3520	601	119595-01350	REC119595-01350	585	121370-77010	PH140-0009	610
104214-13531	HGE3520	601	119595-01800	REC119595-01800	596	121400-11340	REC121400-11340	600
104500-55710	REC104500-55710	605-616-617-618	119595-22300	REC119595-22300	597	121450-01801	REC121450-01801	595
104511-11100	REC104511-11100	600	119609-32040	REC119609-32040	594	121450-02100	REC121450-02100	598
104511-78780	REC104511-78780	602-616-617-618	119612-77230	PH300-0020	611	121450-02110	REC121450-02110	598
104511-78780E	REC104511-78780E	611	119717-02930	REC119717-02930	599	121450-02160	REC121450-02160	599
105225-02020	REC105225-02020	594	119717-11340	REC119717-11340	600	121450-02170	REC121450-02170	598
105225-02040	REC105225-02040	592	119717-11350	REC119717-11350	600	121450-11310	REC121450-11310	589
105225-11100	REC105225-11100	600	119770-00060	REC119770-00060	589	121450-11680	REC121450-11681	591
105225-11110	REC105225-11110	600	119770-00130	REC119770-00130	599	121450-11681	REC121450-11681	591
105582-49200	REC105582-49200	603	119770-00250	REC119770-00250	597	121450-32021	REC121450-32021	606
105582-82041	REC105582-82041	592	119770-00480	REC119770-00480	600	121450-44410	REC121450-44411	604
109005-35170	REC119005-35100	606	119770-00490	REC119770-00490	600	121450-44411	REC121450-44411	604
114361-77011	PH140-0007	610	119770-00930	REC119770-00930	585	121520-01850	REC121520-01851	591
114362-77010	PH140-0007	610	119770-00940	REC119770-00940	586	121520-01851	REC121520-01851	591
114362-77011	PH140-0007	610	119770-00950	REC119770-00950	586	121575-01331	REC121575-01334	584
114399-77010	PH140-0007	610	119770-01010	REC119770-01010	598	121575-01332	REC121575-01334	584
119000-01771	REC119000-01771	591	119770-01020	REC119770-01020	598	121575-01333	REC121575-01334	584
119000-32020	REC119000-32020	607	119770-01030	REC119770-01030	598	121575-01334	REC121575-01334	584
119000-42021	REC119000-42021	603	119770-01040	REC119770-01040	598	121575-01510	REC121575-01510	592
119005-35100	REC119005-35100	606	119770-02031	REC119770-02031	598	121575-01511	REC121575-01510	592
119005-35151	REC119005-35100	606	119770-90090	REC119770-90090	596	121575-01512	REC121575-01510	592
119100-11360	REC119100-11360	589	119770-90290	REC119770-90290	596	121575-01861	REC121575-01861	591
119100-12113	REC119100-12113	589	119770-90620	REC119770-90620	606-620	121575-42200	REC128397-42500	602
119171-11110	REC119171-11110	600	119770-91030	REC119770-91030	599	121750-49800	REC121750-49800	603-616-617-618
119171-11150	REC119171-11150	600	119770-00260	REC119770-00260	598	121850-01800	REC121850-01800	595
119171-13510	REC119171-13510	590	119771-00040	REC119771-00040	589	121850-11100	REC121850-11100	600
119171-18010	REC119171-18010	608	119771-00401	REC119771-00401	585	121850-11150	REC121850-11150	599-600
119172-18011	REC119172-18011	609	119771-00411	REC119771-00411	586	121850-42280E	REC121850-42280E	611
119172-18030	REC119172-18030	609	119771-00421	REC119771-00421	586	121850-49811	REC121850-49811	604-619
119173-11101	REC119173-11101	600	119773-13500	SED3092500	601	121850-51960	REC121850-51960	594
119173-13501	SED3092400	601	119773-13501	SED3092500	601	121857-55710	REC121857-55710	605-619
119173-18011	REC119173-18011	608	119773-42501	REC119773-42502	602	122710-01781	REC122710-01781	595
119173-18041	REC119173-18041	608	119773-42502	REC119773-42502	602	123500-77010	REC123500-77010	610
119174-01340	REC119174-01340	585	119773-42600	REC13554-0001	593	123672-01782	REC123672-01782	596
119174-13201	REC119174-13201	590	119773-42601	REC13554-0001	593	124000-01750	REC124000-01751	590
119175-18031	REC119175-18031	609	119773-42650	REC119773-42502	602	124000-01751	REC124000-01751	590
119181-13500	SED3092401	601	119773-42651	REC119773-42502	602	124085-02220	REC124085-02220	596
119195-18031	REC119195-18031	608	119773-42652	REC119773-42502	602	124085-35113	REC124550-35110	606
119195-18880	REC119195-18880	607-619-620	119773-49550	REC119773-49550	604-620	124160-34844	REC124160-34845	591
119305-35151	REC119305-35151	605-616-617-619	119773-55510	REC119773-55510	604-620	124160-34845	REC124160-34845	591
119573-77200	PH300-0002	611	119773-77010	PH150-0005	610	124223-42091	REC22779-0001	592
119573-77201	PH300-0002	611	119773-77200	PH300-0018	611	124223-42092	REC22779-0001	592
119574-18790	TENO1317T	614-620	119773-77201	PH300-0018	611	124223-42110	REC124223-42110	603
119574-42500	REC119574-42502	602	119773-77250	REC119775-77260	611	124223-49250	REC105582-49200	603
119574-42501	REC119574-42502	602	119775-77260	REC119775-77260	611	124240-01882	REC124240-01883	591
119574-42502	REC119574-42502	602	119802-55810	REC119802-55810	605	124240-01883	REC124240-01883	591
119574-42550	CEF500162G	593	119836-77200	PH300-0020	611	124250-77012	PH150-0004	610
119574-42550	REC119574-42550	593	119836-77201	PH300-0020	611	124411-01780	REC124411-01780	596
119574-42552	CEF500162G	593	120130-91370	REC120130-91370	607	124450-77011	PH150-0004	610
119574-42552	REC119574-42550	593	120324-55760	REC120324-55760	605	124460-11340	REC124460-11340	600



R.O./OEM	REF	PAG	R.O./OEM	REF	PAG	R.O./OEM	REF	PAG
124550-35110	REC124550-35110	606	129150-02800	REC129150-02800	597	196450-02492	CM19642002652Z	612
124610-01861	REC124610-01862	591	129150-02931	REC129150-02931	599	196450-02501	CM19644002660KITA	612
124610-01862	REC124610-01862	591	129150-12111	REC129150-12111	589	196450-02501	CM19644002660KITZ	612
124610-77010	REC123500-77010	610	129150-13110	REC129150-13110	590	196450-02501	TEN01305/1	613
124610-77019	REC123500-77010	610	129150-23601	REC129150-23601	598	196630-02670	TEN01304	613
124770-12540	GS38120	612	129150-35042	REC129150-35042	606	196640-62680	TEN01319	614
124770-12540	REC124770-12540	607	129150-35111	REC129150-35111	603	22190-060002	REC22190-060002	594
124772-08341	GS38108	612	129150-35153	REC129150-35153	606	22190-080002	REC22190-080002	594
124772-77010	PH150-0004	610	129150-35170	REC129150-35170	606	22190-100002	REC22190-100002	595
124772-77020	PH150-0004	610	129150-42020	REC129486-42050	603	22190-120002	REC22190-120002	595
124950-11340	REC124950-11340	599	129150-77511	REC129150-77511	589	22190-140002	REC22190-140002	595
126650-35350	REC126650-35350	605	129171-01330	REC129171-01330	584	22190-240002	REC22190-240002	595
127070-13520	HGE3520	601	129198-01750	REC129198-01750	590	23414-080000	REC23414-080000	593
127605-48590	REC127605-48590	604	129242-77010	PH140-0009	610	23414-100000	REC23414-100000	593
127610-22501	REC127610-22501	597	129271-42500	REC129271-42502	602	23414-120000	REC23414-120000	593
127610-42200	REC3841697	592	129271-42501	REC129271-42502	602	23414-250000	REC23414-250000	593
127610-91350	REC127610-91350	607	129271-42502	REC129271-42502	602	24311-000100	REC24311-000100	594
127616-11280	REC127616-11280	599	129350-49540	REC129350-49541	604	24311-000120	REC24311-000120	594
127692-18880	REC127692-18880	607	129350-49541	REC129350-49541	604	24311-000160	REC24311-000160	594
127695-35150	REC127695-35150	606	129400-01750	REC129400-01751	591	24311-000320	REC24311-000320	594
127695-35160	REC127695-35150	606-618-619-620	129400-01751	REC129400-01751	591	24311-000700	REC24311-000700	594
127695-55630	REC127695-55630	604-605-619-620	129407-01340	REC129407-01340	585	24321-000350	REC24321-000350	594
128170-01331	REC128170-01331	584	129408-01330	REC129408-01330	585	24325-000350	REC24325-000350	594
128170-01510	REC128170-01510	592	129429-77010	REC121254-77012	610	24341-000240	REC24341-000240	594
128170-01511	REC128170-01510	592	129429-77011	REC121254-77012	610	25132-002700	REC25132-002700	611
128170-01750	REC128170-01751	590	129470-01550	REC129470-01550	594	25132-003100	REC25132-003100	611-616
128170-01751	REC128170-01751	590	129470-12130	REC129470-12130	589	25132-003700	REC25132-003700	611-616-617
128170-03070	REC128170-03070	591	129470-12330	REC129470-12330	607-617-618-619	25132-004250	REC25132-004250	611-619-620
128170-11310	REC128170-11310	589	129470-13560	MAR13561	601	25132-004500	REC25132-004500	611-617-618-619
128170-12540	REC128170-12540	607-616	129470-13561	MAR13561	601	25132-004600	REC25132-004600	611-618
128170-13201	REC128170-13201	590	129470-35040	REC129470-35040	606	251321-003000	REC251321-003000	611
128170-32030	REC128170-32030	606	129470-35121	REC129470-35121	607	25152-004300	REC25152-004300	611-618
128170-42090	REC128170-42090	603	129470-42352	REC21213660	593	27200-300400	TEN01311	613-620
128170-77010	PH140-0008	610	129470-42530	REC21213660	593	27200-400400	TEN01310	613
128170-77010D	PH140-0008	610	129470-49801	REC129470-49801	603-617-618-619	27210-200200	TEN01303	613-616-620
128170-77350	REC128170-77350	611-616	129470-55703	REC129470-55703	605-617-618	27210-200300	CMC272100-20030	612-616-617-618-619-620
128171-01330	REC128171-01911	584	129470-77200	PH300-0002	611	27210-200300	TEN01301	613-620
128171-01911	REC128171-01911	584	129472-18090	REC129472-18090	590	27210-200370	TEN01312	613-619-620
128171-77200	PH300-0005	611	129473-18000	REC129473-18000	609	27210-200370	TEN01316	614-619-620
128176-42080	CEF500113	592	129486-42050	REC129486-42050	603	27210-200370	TEN01318	614
128176-42080	REC1411-0001	592	129497-18000	REC129497-18000	609	27210-200550	TEN01306	613
128270-08341	GS38107	612	129550-13110	REC129550-13110	590	41650-501140	REC41650-501140	605-620
128270-11310	REC105225-0240	589	129553-01350	REC129553-01350	585	41650-502320	REC41650-502320	605-619
128270-12540	REC128270-12540	607-616-618-619	129573-1351	REC129573-01351	585	41650-502330	REC41650-502330	605-620
128270-42000	REC728270-42002	602	129573-77010	PH150-0004	610	424610-77010	REC123500-77010	610
128270-42001	REC728270-42002	602	129574-55711	REC129574-55711	605-618	429670-42510	REC129670-42513	602
128270-42002	REC728270-42002	602	129579-13551	MAR13552	601	429670-42511	REC129670-42513	602
128270-77200	PH300-0005	611	129590-22510	REC129590-22510	597	43400-500390	REC43400-500390	595
128270-77201	PH300-0005	611	129601-11310	REC129601-11310	589	43400-500450	REC43400-500450	595
128270-77202	PH300-0005	611	129608-77010	PH140-0009	610	704571-22500	REC704571-22500	597
128271-01911	REC128271-01911	584	129612-42290E	REC129612-42290E	611	705311-22500	REC721575-22500	596
128275-91340	REC128275-91340	607	129670-42500	REC129670-42513	602	705311-23600	REC705311-23600	598
128296-42070	REC22779-0001	592	129670-42501	REC129670-42513	602	719000-02800	REC719000-02800	597
128300-13230	REC128300-13230	590	129670-42502	REC129670-42513	602	719000-02930	REC719000-02930	599
128370-01331	REC128370-01332	584	129670-42512	REC129670-42513	602	719000-22501	REC719000-22501	597
128370-01332	REC128370-01332	584	129670-42513	REC129670-42513	602	719171-92602	REC719171-92602	585-588
128370-13181	REC128370-13181	590	129670-42530	REC21213660	593	719173-92600	REC719173-92600	585-588
128370-13600	HGE3520	601	129670-42531	REC21213660	593	719174-23601	REC719174-23601	598
128374-01911	REC128374-01911	584	129671-13551	MAR13552	601	719593-02590	REC719593-02590	599
128377-42500	REC128377-42500	602	129671-18001	REC129671-18001	608	719593-23601	REC719593-23601	598
128397-42500	REC128397-42500	602	129690-02800	REC129690-02800	597	719595-23600	REC719595-23600	598
128610-01650	REC128610-01650	596	129693-01331	REC129693-01331	585	719717-02901	REC719717-02901	597
128610-02131	REC128610-02131	598	129698-77010	PH140-0009	610	72100-22500	REC721000-22500	596
128610-02250	REC128610-02250	599	129772-77200	PH300-0002	611	721575-22500	REC721575-22500	596
128619-11100	REC128619-11100	600	129792-13550	MAR13552	601	724770-13200	MAR13200	601
128619-11110	REC128619-11110	600	129792-13551	MAR13552	601	728170-92600	REC728170-92600	584-586
128620-42200	REC22779-0001	592	129792-13552	MAR13552	601	728171-92601	REC728171-92601	584-586
128625-01342	REC128625-01342	585	129795-01800	REC129795-01800	595	728176-92600	REC728176-92600	586
128625-23361	REC128625-23361	598	129795-49551	REC129795-49551	604	728271-92605	REC728271-92605	584-586
128628-42203	REC128628-42203	593	129930-77211	PH300-0020	611	728277-92606	REC728277-92606	586
128633-35400	REC128633-35400	606-620	129940-42310E	REC129940-42310E	611	728370-92600	REC728370-92605	587
128670-77350	REC128670-77350	611-617	145640-48410	REC145640-48410	604-619-620	728370-92605	REC728370-92605	587
128671-01330	REC128671-01330	584	165000-69950	REC165000-69950	604	728374-92605	REC728374-92605	584-587
128990-13520	HGE3520	601	171008-77010	PH150-0004	610	728623-92601	REC728623-92601	585-588
128990-42200	REC653-0001	592	171058-77010	REC121254-77012	610	728633-22500	REC728633-22500	597
128990-42510	REC128397-42500	602	177301-54900	TEN01317	614-619	728670-92600	REC728670-92600	587
128990-42570	REC653-0001	592	177301-54900	TEN01306	613	728670-92601	REC728670-92602	587
128990-49800	REC128990-49800	603-617	181130-49200	REC105582-49200	603	729120-22500	REC729120-22500	596
129001-01340	REC129001-01340	584	119593-11380	REC119593-11380	589	729171-92600	REC729171-92600	584-587
129001-02931	REC129001-02931	598	196350-02350	TEN01394-1	614	729270-92601	REC729270-92601	584-587
129002-01331	REC129002-01331	584	196350-02550	TEN01390-1	613	729271-92600	REC729271-92600	584-587
129005-11100	REC129005-11100	600	196350-02570	TEN01391-1	613	729407-92600	REC729407-92605	588
129005-22500	REC129005-22500	596	196350-07360	TEN01393-1	613	729407-92605	REC729407-92605	588
129100-01621	REC129100-01621	592	196350-09910	TEN01392-1	614	729408-92600	REC729408-92605	588
129100-11100	REC129100-11100	600	196420-02652	CM19642002652A	612	729408-92605	REC729408-92605	588
129100-11112	REC129100-11112	600	196420-02652	CM19642002652Z	612	729470-92605	REC729470-92605	585-588
129120-11100	REC129120-11100	600	196440-02660	CM19644002660KITA	612	729573-92605	REC729573-92605	585-587
129120-11110	REC129120-11110	600	196440-02660	CM19644002660KITZ	612	729593-02800	REC719593-02800	598
129120-35121	REC129120-35121	606	196440-02660	TEN01305/1	613	978670-92602	REC728670-92602	587
129150-01511	REC129150-01511	592	196440-02690	TENPLAC-1	613	XN199611	RECXN199611	607-619
129150-01531	REC129150-01531	592	196450-02492	CM19642002652A	612			
129150-01881	REC129150-01881	603						

# OTRAS MARCAS

<b>BORG-WAGNER</b>	<b>628</b>	<b>KITS CONVERSIÓN ELECTRÓNICO</b>	<b>650</b>	<b>PLEASURECRAFT</b>	<b>672</b>
<b>COMPONENTES</b>	<b>628</b>	<b>BOBINAS DE ENCENDIDO</b>	<b>651</b>	<b>JUNTAS MOTOR</b>	<b>672</b>
• FILTROS DE ACEITE	628	• JUEGOS DE CABLE PARA BUJÍAS	651	• JUNTAS CULATA	672
• KITS REPARACIÓN TRANSMISIÓN	628	<b>MOTORES DE ARRANQUE</b>	<b>652</b>	• JUNTAS COLECTOR ESCAPE	672
• DAMPER	628	• EXTENSOR DE SOLENOIDE	652	<b>COLECTORES, CODOS Y JUNTAS</b>	<b>672</b>
<b>CATERPILLAR</b>	<b>629</b>	<b>CUMMINS</b>	<b>653</b>	• PROTECTOR SALIDA ESCAPE	673
<b>COLECTOR</b>	<b>629</b>	<b>COLECTOR</b>	<b>653</b>	• TAPÓN DRENAJE	673
<b>ENFRIADOR DE COMBUSTIBLE</b>	<b>629</b>	<b>BOMBAS DE AGUA MARINA</b>	<b>653</b>	<b>BOMBA CIRCULACIÓN BLOQUE</b>	<b>673</b>
<b>BOMBA ASPIRACIÓN AGUA MARINA</b>	<b>629</b>	<b>IMPULSORES</b>	<b>655</b>	<b>BOMBA ASPIRACIÓN AGUA MARINA</b>	<b>673</b>
<b>IMPULSORES</b>	<b>630</b>	<b>MOTORES DE ARRANQUE</b>	<b>655</b>	• KITS	674
<b>FILTRO DE ACEITE</b>	<b>630</b>	<b>ALTERNADORES</b>	<b>655</b>	<b>TERMOSTATOS</b>	<b>674</b>
<b>ALTERNADORES</b>	<b>630</b>	<b>SILENTBLOCK</b>	<b>655</b>	• TERMOSTATOS Y KITS	674
<b>MOTORES DE ARRANQUE</b>	<b>631</b>	<b>ÁNODOS DE ZINC</b>	<b>656</b>	<b>BOMBAS COMBUSTIBLE</b>	<b>674</b>
<b>SILENTBLOCK</b>	<b>631</b>	<b>DETROIT DIESEL</b>	<b>656</b>	• JUNTA BOMBA	674
<b>ÁNODOS DE ZINC</b>	<b>631</b>	<b>656</b>	<b>656</b>	<b>FILTROS ACEITE</b>	<b>675</b>
<b>CHRIST-CRAFT</b>	<b>632</b>	<b>CODO DE ESCAPE</b>	<b>656</b>	<b>CARBURADORES</b>	<b>675</b>
<b>JUNTAS CULATA</b>	<b>632</b>	<b>BOMBA DE AGUA MARINA</b>	<b>657</b>	• KITS CARBURADOR	675
<b>COLECTORES, CODOS Y JUNTAS</b>	<b>633</b>	<b>ÁNODOS DE ZINC</b>	<b>657</b>	• CHOKE TERMOSTATO	675
• PROTECTOR SALIDA ESCAPE	633	<b>IMPULSORES</b>	<b>658</b>	<b>SENSORES</b>	<b>675</b>
<b>BOMBA DE AGUA</b>	<b>633</b>	<b>HURT</b>	<b>658</b>	• SENSOR DE PRESIÓN DE ACEITE	675
• JUNTA BOMBA	634	<b>COMPONENTES</b>	<b>658</b>	• SENSOR DE PICADO	675
• KITS BOMBA SHERWOOD	634	• KITS REPARACIÓN TRANSMISIÓN	658	• SENSOR ÁRBOL DE LEVAS	676
<b>BOMBAS COMBUSTIBLE</b>	<b>634</b>	• FILTRO TRANSMISIÓN	658	• SENSOR IAC	676
• JUNTA BOMBA	634	<b>INDMAR</b>	<b>659</b>	<b>ENCENDIDO</b>	<b>676</b>
<b>FILTROS ACEITE</b>	<b>634</b>	<b>COLECTORES, CODOS Y JUNTAS</b>	<b>659</b>	• TAPAS DISTRIBUIDOR	676
<b>CARBURADORES</b>	<b>635</b>	<b>BOMBA DE AGUA</b>	<b>660</b>	• PLATINO	676
• KITS CARBURADOR	635	• IMPULSOR	<b>660</b>	• CONDENSADORES	677
• BOYAS	635	<b>TUBO COMBUSTIBLE</b>	<b>660</b>	• ROTORES	677
• TUBO COMBUSTIBLE	635	<b>ENCENDIDO</b>	<b>660</b>	• KITS DE ENCENDIDO	677
<b>ENCENDIDO</b>	<b>635</b>	• PLATINO	<b>660</b>	• DISTRIBUIDOR	677
• TAPAS DISTRIBUIDOR	635	• CONDENSADORES	<b>660</b>	<b>KITS CONVERSIÓN ELECTRÓNICO</b>	<b>678</b>
• PLATINO	636	• ROTORES	<b>660</b>	<b>BOBINAS DE ENCENDIDO</b>	<b>679</b>
• CONDENSADORES	636	• BOBINA	<b>660</b>	• JUEGOS DE CABLE PARA BUJÍAS	679
• ROTORES	636	• JUEGOS DE CABLE PARA BUJÍAS	<b>661</b>	<b>MOTORES DE ARRANQUE</b>	<b>679</b>
• KITS DE ENCENDIDO	636	<b>MOTORES DE ARRANQUE</b>	<b>661</b>	<b>ALTERNADORES</b>	<b>680</b>
• DISTRIBUIDOR	637	<b>ALTERNADORES</b>	<b>661</b>	<b>SOLENOIDES</b>	<b>681</b>
• JUNTA DE DISTRIBUIDOR	637	<b>KOHLER</b>	<b>661</b>	<b>POWER TRIM</b>	<b>681</b>
<b>KITS CONVERSIÓN ELECTRÓNICO</b>	<b>637</b>	<b>COMPONENTES</b>	<b>662</b>	• LATIGUILLOS	681
<b>BOBINAS DE ENCENDIDO</b>	<b>637</b>	• FILTRO COMBUSTIBLE	<b>662</b>	• ADAPTADOR DE GOMA	681
<b>MOTORES DE ARRANQUE</b>	<b>638</b>	• FILTROS DE ACEITE	<b>662</b>	<b>COMPONENTES DE COLA</b>	<b>681</b>
<b>CRUSADER</b>	<b>638</b>	• KITS DE TERMOSTATO	<b>662</b>	• CIERRE DE HÉLICE	681
<b>JUNTAS MOTOR</b>	<b>638</b>	<b>BOMBAS DE AGUA</b>	<b>663</b>	<b>RENAULT COUACH</b>	<b>682</b>
• JUNTAS CULATA	638	<b>ÁNODOS DE ZINC</b>	<b>663</b>	<b>FILTRO DE ACEITE</b>	<b>682</b>
• JUNTAS TAPA BALANCINES	639	<b>IMPULSORES</b>	<b>663</b>	<b>IMPULSORES</b>	<b>682</b>
• JUNTAS COLECTOR ESCAPE	639	<b>MAN</b>	<b>664</b>	<b>ÁNODOS DE ZINC</b>	<b>683</b>
• JUNTAS ADMISIÓN	639	<b>IMPULSORES</b>	<b>664</b>	<b>SOLE DIESEL</b>	<b>683</b>
• JUNTAS TAPA CADENA DISTRIBUCIÓN	639	<b>NANNI DIESEL</b>	<b>664</b>	<b>ÁNODOS DE ZINC</b>	<b>683</b>
<b>COLECTORES DE ESCAPE</b>	<b>639</b>	<b>IMPULSORES</b>	<b>664</b>	<b>IMPULSORES</b>	<b>683</b>
<b>CODOS, SUPLEMENTOS Y KITS</b>	<b>640</b>	<b>ALTERNADOR</b>	<b>664</b>	<b>VETUS</b>	<b>684</b>
• JUNTA CODO	642	<b>ONAN</b>	<b>664</b>	<b>ÁNODOS DE ZINC</b>	<b>684</b>
• PROTECTOR SALIDA ESCAPE	642	<b>COMPONENTES</b>	<b>665</b>	<b>IMPULSORES</b>	<b>684</b>
<b>BOMBA CIRCULACIÓN BLOQUE</b>	<b>642</b>	• FILTRO DE COMBUSTIBLE	<b>665</b>	<b>WESTERBEKE</b>	<b>686</b>
<b>BOMBA ASPIRACIÓN AGUA MARINA</b>	<b>643</b>	• FILTRO DE ACEITE	<b>665</b>	<b>COMPONENTES</b>	<b>686</b>
• RACORD MANGUERA CODO	643	<b>BOMBA DE AGUA MARINA</b>	<b>665</b>	• FILTROS DE ACEITE	686
• COJINETE BOMBA SHERWOOD	643	<b>BOMBA DE AGUA</b>	<b>666</b>	• KITS DE CARBURADOR	686
• KITS BOMBA SHERWOOD	643	<b>IMPULSORES</b>	<b>667</b>	• MOTOR DE ARRANQUE	686
• KIT RETÉN	643	<b>ÁNODOS DE ZINC</b>	<b>668</b>	• ALTERNADOR	686
<b>BOMBAS DE COMBUSTIBLE</b>	<b>644</b>	<b>PERKINS</b>	<b>669</b>	<b>ÁNODOS DE ZINC</b>	<b>686</b>
<b>TERMOSTATOS</b>	<b>644</b>	<b>COMPONENTES</b>	<b>669</b>	<b>BOMBAS DE AGUA</b>	<b>687</b>
• TERMOSTATOS Y KITS	644	• COLECTOR	<b>669</b>	<b>IMPULSORES</b>	<b>687</b>
<b>FILTROS Y ELEMENTOS</b>	<b>644</b>	• CODOS	<b>669</b>	<b>SHERWOOD</b>	<b>688</b>
• FILTRO SEPARADOR DE AGUA	644	• FILTRO DE COMBUSTIBLE	<b>669</b>	<b>JABSCO</b>	<b>698</b>
• FILTROS DE COMBUSTIBLE	644	• FILTRO DE ACEITE	<b>669</b>	• GUÍA DE IMPULSORES	699
• FILTRO DE ACEITE	644	<b>BOMBA DE AGUA MARINA</b>	<b>670</b>	<b>FILTRACIÓN</b>	<b>701</b>
<b>CARBURADORES</b>	<b>645</b>	<b>BOMBAS DE AGUA</b>	<b>670</b>	<b>ÍNDICE REF</b>	<b>707</b>
• KITS CARBURADOR	645	<b>ÁNODOS DE ZINC</b>	<b>671</b>	<b>GARANTÍA LIMITADA</b>	<b>714</b>
• BOYAS	646	<b>IMPULSORES</b>	<b>671</b>		
• APAGALLAMAS	646	<b>MOTORES DE ARRANQUE</b>	<b>671</b>		
• TUBO COMBUSTIBLE	646				
<b>SENSORES</b>	<b>646</b>				
• SENSOR DE TEMPERATURA ACEITE	646				
• SENSOR TEMPERATURA AGUA	646				
• SENSOR TPS	647				
• SENSOR IAC	647				
• SENSOR TEMPERATURA ENFRIADOR	647				
<b>ENCENDIDO</b>	<b>647</b>				
• TAPAS DISTRIBUIDOR	647				
• PLATINOS	648				
• CONDENSADORES	648				
• ROTORES	648				
• KITS DE ENCENDIDO	649				
• DISTRIBUIDORES	649				
<b>MÓDULOS DE ENCENDIDO</b>	<b>650</b>				

# OTHER BRANDS

## BORG-WAGNER 628

- PARTS** 628
- OIL FILTERS 628
  - TRANSMISION REPAIR KIT 628
  - DAMPER 628

## CATERPILLAR 629

- MANIFOLD** 629
- FUEL COOLER** 629
- WATER PUMPS** 629
- RAW MARINE WATER PUMPS** 630
- IMPELLERS** 630
- OIL FILTERS** 630
- ALTERNATORS** 630
- STARTERS** 631
- SILENTBLOCK** 631
- ZINC ANODES** 631

## CHRIST-CRAFT 632

- MANIFOLD GASKETS** 632
- MANIFOLDS, ELBOWS & GASKETS** 633
  - EXHAUST PROTECTOR VALVE 633
- WATER PUMP** 633
  - PUMP GASKET 634
  - PUMP KIT SHERWOOD 634
- FUEL PUMPS** 634
  - PUMP GASKET 634
- OIL PUMPS** 634
- CARBURETORS** 635
  - KITS CARBURETOR 635
  - FLOATS 635
  - FUEL TUBE 635
- IGNITION** 635
  - DISTRIBUTOR CAPS 635
  - POINTS 636
  - CONDENSERS 636
  - ROTORS 636
  - IGNITION KITS 636
  - DISTRIBUTOR 637
  - DISTRIBUTOR GASKET 637
- ELECTRONIC CONVERSION KITS** 637
- IGNITION COILS** 638
- STARTERS** 638

## CRUSADER 638

- ENGINE GASKETS** 638
  - MANIFOLD GASKETS 638
  - VALVE COVER GASKETS 639
  - EXHAUST MANIFOLD GASKETS 639
  - INTAKE GASKETS 639
  - TIMING CHAIN COVER GASKET 639
- EXHASUT MANIFOLDS** 639
- ELBOWS, RISERS & KITS** 640
  - ELBOW GASKETS 642
  - EXHAUST PROTECTOR VALVE 642
- BLOCK CIRCULATING PUMP** 642
- RAW MARINE WATER PUMPS** 643
  - WATER FITTING 643
  - BEARING SHERWOOD PUMP 643
  - PUMP SHERWOOD KIT 643
  - KIT SEALS 643
- FUEL PUMPS** 644
- THERMOSTATS** 644
  - THERMOSTATS & KITS 644
- FILTERS & ELEMENTS** 644
  - WATER SEPARATING FUEL FILTER 644
  - FUEL FILTERS 644
  - OIL FILTERS 644
- CARBURETORS** 645
  - KITS CARBURETOR 645
  - FLOATS 646
  - FLAME ARRESTORS 646
  - FUEL TUBE 646
- SENSORS** 646
  - OIL TEMPERATURE SENSOR 646
  - WATER TEMPERATURE SENSOR 646
  - TPS SENSOR 647
  - IAC SENSOR 647
  - COOLANT TEMPERATURE SENSOR 647
- IGNITION** 647
  - DISTRIBUTOR CAPS 647
  - POINTS 648
  - CONDENSERS 648
  - ROTORS 648
  - IGNITION KITS 649
  - DISTRIBUTORS 649

- IGNITION MODULE** 650
- ELECTRONIC CONVERSION KITS** 650
- IGNITION COILS** 651
  - SPARK PLUG WIRE SET 651
- STARTERS** 652
  - SOLENOID EXTENSOR FOR TERMINALS 652

## CUMMINS 629

- MANIFOLD** 629
- MARINE WATER PUMPS** 629
- IMPELLERS** 630
- STARTERS** 630
- ALTERNATORS** 630
- SILENTBLOCK** 630
- ZINC ANODES** 631

## DETROIT DIESEL 656

- EXHAUST ELBOW** 656
- MARINE WATER PUMP** 657
- ZINC ANODES** 657
- IMPELLERS** 658

## HURT 658

- PARTS** 658
- TRANSMISION REPAIR KIT 658
  - TRANSMISION FILTER 658

## INDMAR 659

- MANIFOLDS, ELBOWS & GASKETS** 659
- WATER PUMP** 660
  - IMPELLER 660
- FUEL TUBE** 660
- IGNITION** 660
  - POINT 660
  - CONDENSERS 660
  - ROTORS 660
  - COILS 661
  - SPARK PLUG WIRE SET 661
- STARTERS** 661
- ALTERNATORS** 661

## KOHLER 662

- PARTS** 662
- FUEL FILTER 662
  - OIL FILTERS 662
  - THERMOSTAT KIT 662
- ZINC ANODES** 663
  - WATER PUMPS** 663
  - IMPELLERS** 663

## MAN 664

- IMPELLERS** 664

## NANNI DIESEL 664

- IMPELLERS** 664
- ALTERNATORS** 664

## ONAN 665

- PARTS** 665
- FUEL FILTERS 665
  - OIL FILTERS 665
- MARINE WATER PUMP** 666
  - WATER PUMP** 667
  - IMPELLERS** 668
  - ZINC ANODES** 668

## PERKINS 669

- PARTS** 669
- MANIFOLD 669
  - ELBOWS 669
  - FUEL FILTERS 669
  - OIL FILTERS 669
- MARINE WATER PUMP** 670
  - WATER PUMPS** 670
  - ZINC ANODES** 671
  - IMPELLERS** 671
  - STARTERS** 671

## PLEASURECRAFT 672

- ENGINE GASKETS** 672
  - MANIFOLD GASKETS 672
  - EXHAUST MANIFOLD GASKETS 672
- MANIFOLDS, ELBOWS & GASKETS** 672
  - EXHAUST PROTECTOR VALVE 673
  - DRAIN TAP 673
- BLOCK CIRCULATING PUMP** 673
- RAW MARINE WATER PUMPS** 673
  - KITS 674
- THERMOSTATS** 674
  - THERMOSTATS & KITS 674
- FUEL PUMPS** 674
  - PUMP GASKET 674
- OIL PUMPS** 675
- CARBURETORS** 675
  - KITS CARBURETOR 675
  - THERMOSTAT CHOKE 675
- SENSORS** 675
  - OIL PRESSURE SENSOR 675
  - KNOCK SENSOR 675
  - CAMSHAFT SENSOR 676
  - IAC SENSOR 676
- IGNITION** 676
  - DISTRIBUTOR CAPS 676
  - POINT 676
  - CONDENSERS 677
  - ROTORS 677
  - IGNITION KITS 677
  - DISTRIBUTOR 677
- ELECTRONIC CONVERSION KITS** 678
- IGNITION COILS** 679
  - SPARK PLUG WIRE SET 679
- STARTERS** 679
- ALTERNATORS** 680
- SOLENOIDS** 681
- POWER TRIM** 681
  - TRIM HOSES 681
  - BUSHING 681
- GEARHOUSING COMPONENTS** 681
  - PROP HARDWARE 681

## RENAULT COUACH 682

- OIL FILTERS** 682
- IMPELLERS** 682
- ZINC ANODES** 683

## SOLE DIESEL 683

- ZINC ANODES** 683
- IMPELLERS** 683

## VETUS 684

- ZINC ANODES** 684
- IMPELLERS** 684

## WESTERBEKE 686

- PARTS** 686
- OIL FILTERS 686
  - CARBURETOR KITS 686
  - STARTER 686
  - ALTERNATOR 686
- ZINC ANODES** 686
  - WATER PUMPS** 687
  - IMPELLERS** 687

## SHERWOOD 688

- JABSCO** 698
  - IMPELLERS APPLICATIONS 699

## FILTERS 701

## REF TABLE 707

## LIMITED WARANTY 714

# ALTRE MARCHE

<b>BORG-WAGNER</b>	<b>628</b>	<b>KIT CONVERSIONE ELETTRONICO</b>	<b>650</b>	<b>PLEASURECRAFT</b>	<b>672</b>
<b>COMPONENTI</b>	<b>628</b>	<b>BOBINA ACCENSIONE</b>	<b>651</b>	<b>GUARNIZIONE MOTORE</b>	<b>672</b>
• FILTRO DELL'OLIO	628	• KIT CAVI CANDELE	651	• GUARNIZIONE TESTATA	672
• KIT RIPARAZIONE TRASMISSIONE	628	<b>MOTORINO D'AVVIAMENTO</b>	<b>652</b>	• GUARNIZIONE COLLETTORE SCARICO	672
• DAMPER	628	• PROLUNGA TERMINALE PER SOLENOIDE	652	<b>COLLETTORI, GOMITO E GUARNIZIONES</b>	<b>672</b>
<b>CATERPILLAR</b>	<b>629</b>	<b>CUMMINS</b>	<b>653</b>	• PROTEZIONE SCARICO	673
<b>COLLETTORE</b>	<b>629</b>	<b>COLLETTORE</b>	<b>653</b>	• TAPPO DI DRENAGGIO	673
<b>SCAMBIATORE DE COMBUTIBILE</b>	<b>629</b>	<b>POMPA ACQUA MARINA</b>	<b>653</b>	<b>POMPA DI RICIRCOLO DI BLOCCO</b>	<b>673</b>
<b>POMPE ASPIRAZIONE ACQUA MARINA</b>	<b>629</b>	<b>GIRANTI</b>	<b>655</b>	<b>POMPE ASPIRAZIONE ACQUA MARINA</b>	<b>673</b>
<b>GIRANTI</b>	<b>630</b>	<b>MOTORINO D'AVVIAMENTO</b>	<b>655</b>	• KIT	674
<b>FILTRO DELL'OLIO</b>	<b>630</b>	<b>ALTERNATORI</b>	<b>655</b>	<b>TERMOSTATO</b>	<b>674</b>
<b>ALTERNATORI</b>	<b>630</b>	<b>SILENTBLOCK</b>	<b>656</b>	• TERMOSTATOE KIT	674
<b>MOTORINO DI AVVIAMENTO</b>	<b>631</b>	<b>ANODO DI ZINCO</b>	<b>656</b>	<b>POMPE COMBUSTIBILE</b>	<b>674</b>
<b>SILENTBLOCK</b>	<b>631</b>	<b>DETROIT DIESEL</b>	<b>656</b>	• GUARNIZIONE POMPA	674
<b>ANODO DI ZINCO</b>	<b>631</b>	<b>GOMITO SCARICO</b>	<b>656</b>	<b>FILTRI DELL'OLIO</b>	<b>675</b>
<b>CHRIST-CRAFT</b>	<b>632</b>	<b>POMPE ACQUA MARINA</b>	<b>657</b>	<b>CARBURATORI</b>	<b>675</b>
<b>GUARNIZIONE TESTATA</b>	<b>632</b>	<b>ANODO DI ZINCO</b>	<b>658</b>	• KIT CARBURATORE	675
<b>COLLETTORI, GOMITI E GUARNIZIONI</b>	<b>633</b>	<b>GIRANTI</b>	<b>658</b>	• CHOKE TERMOSTATO	675
• PROTEZIONE SCARICO	633	<b>HURT</b>	<b>658</b>	<b>SENSORI</b>	<b>675</b>
<b>POMPE ACQUA</b>	<b>633</b>	<b>COMPONENTI</b>	<b>658</b>	• SENSORE PRESSIONE DELL'OLIO	675
• GUARNIZIONE POMPA	634	• KIT RIPARAZIONE TRASMISSIONE	658	• SENSORE DI ANTICIPO	675
• KITS POMPA SHERWOOD	634	• FILTRO TRASMISSIONE	658	• SENSORE ALBERO A CAMME	676
<b>POMPE COMBUSTIBILE</b>	<b>634</b>	<b>INDMAR</b>	<b>659</b>	• SENSORE IAC	676
• GUARNIZIONE POMPA	634	<b>COLLETTORE, GOMITO E GUARNIZIONES</b>	<b>659</b>	<b>ACCENSIONE</b>	<b>676</b>
<b>FILTRI DELL'OLIO</b>	<b>634</b>	<b>POMPE ACQUA</b>	<b>660</b>	• CALOTTE SPINTEROGENI	676
<b>CARBURATORI</b>	<b>635</b>	• GIRANTE	<b>660</b>	• PUNTINE	676
• KIT CARBURATORE	635	<b>TUBO COMBUSTIBILE</b>	<b>660</b>	• CONDENSATORE	677
• GALLEGGIANTI	635	<b>ACCENSIONE</b>	<b>660</b>	• ROTORI	677
• TUBO COMBUSTIBILE	635	• PUNTINE	660	• KITS ACCENSIONE	677
<b>ACCENSIONE</b>	<b>635</b>	• CONDENSATORE	660	• SPINTEROGENI	677
• CALOTTE SPINTEROGENI	635	• ROTORI	660	• GUARNIZIONE SPINTEROGENI	637
• PUNTINE	636	• BOBINA	661	<b>KIT CONVERSIONE ELETTRONICO</b>	<b>637</b>
• CONDENSATORE	636	• KIT CAVI CANDELE	661	<b>BOBINE DE ACCENSIONE</b>	<b>638</b>
• ROTORI	636	<b>MOTORINO DI AVVIAMENTO</b>	<b>661</b>	<b>MOTORINO D'AVVIAMENTO</b>	<b>638</b>
• KIT ACCENSIONE	636	<b>ALTERNATORI</b>	<b>661</b>	<b>CRUSADER</b>	<b>638</b>
• SPINTEROGENI	637	<b>KOHLER</b>	<b>662</b>	<b>GUARNIZIONE MOTORE</b>	<b>638</b>
• GUARNIZIONE SPINTEROGENI	637	<b>COMPONENTI</b>	<b>662</b>	• GUARNIZIONE TESTATA	638
<b>KIT CONVERSIONE ELETTRONICO</b>	<b>637</b>	• FILTRO COMBUSTIBILE	662	• GUARNIZIONE COPERCHIO PUNTERIE	639
<b>BOBINE DE ACCENSIONE</b>	<b>638</b>	• FILTRO DELL'OLIO	662	• GUARNIZIONE COLLETTORE SCARICO	639
<b>MOTORINO D'AVVIAMENTO</b>	<b>638</b>	• KITS DE TERMOSTATO	662	• GUARNIZIONE ASPIRAZIONE	639
<b>COLLETTORE SCARICO</b>	<b>639</b>	<b>ANODO DI ZINCO</b>	<b>663</b>	• GUARNIZIONE CATENA CARTER DISTRIBUZIONE	639
<b>GOMITI, DISTANZIALE E KITS</b>	<b>640</b>	<b>POMPA ACQUA</b>	<b>663</b>	<b>MAN</b>	<b>664</b>
• GUARNIZIONE GOMITI	642	<b>GIRANTI</b>	<b>662</b>	<b>GIRANTI</b>	<b>664</b>
• PROTEZIONE SCARICO	642	<b>MAN</b>	<b>664</b>	<b>NANNI DIESEL</b>	<b>664</b>
<b>POMPA DI RICIRCOLO DI BLOCCO</b>	<b>642</b>	<b>GIRANTI</b>	<b>664</b>	<b>GIRANTI</b>	<b>664</b>
<b>POMPE ASPIRAZIONE ACQUA MARINA</b>	<b>643</b>	<b>ALTERNATORE</b>	<b>664</b>	<b>ONAN</b>	<b>665</b>
• RACCORDO TUBI GOMITO	643	<b>ONAN</b>	<b>665</b>	<b>COMPONENTI</b>	<b>665</b>
• CUSCINETTO POMPA SHERWOOD	643	<b>COMPONENTI</b>	665	• FILTRO COMBUSTIBILE	665
• KIT POMPA SHERWOOD	643	• FILTRO OLIO	665	• POMPE ACQUA MARINA	<b>666</b>
• KIT PARAOLIO	643	<b>POMPE ACQUA MARINA</b>	<b>666</b>	<b>POMPE ACQUA</b>	<b>667</b>
<b>TERMOSTATO</b>	<b>644</b>	<b>GIRANTI</b>	<b>668</b>	<b>GIRANTI</b>	<b>668</b>
• TERMOSTATO E KIT	644	<b>ANODO DI ZINCO</b>	<b>668</b>	<b>PERKINS</b>	<b>669</b>
<b>POMPA COMBUSTIBILE</b>	<b>644</b>	<b>PERKINS</b>	<b>669</b>	<b>COMPONENTI</b>	<b>669</b>
<b>FILTRI E ELEMENTI</b>	<b>644</b>	<b>COMPONENTI</b>	669	• COLLETTORE	669
• FILTRO SEPARATORE ACQUA	644	• GOMITI	669	• FILTRO COMBUSTIBILE	669
• FILTRO COMBUSTIBILE	644	• FILTRO OLIO	669	<b>POMPE ACQUA MARINA</b>	<b>670</b>
• FILTRO DELL'OLIO	644	<b>POMPE ACQUA MARINA</b>	<b>670</b>	<b>POMPA ACQUA</b>	<b>670</b>
<b>CARBURATORI</b>	<b>645</b>	<b>GIRANTI</b>	<b>671</b>	<b>ANODO DI ZINCO</b>	<b>671</b>
• KIT CARBURATORE	645	<b>ANODO DI ZINCO</b>	<b>671</b>	<b>GIRANTI</b>	<b>671</b>
• GALLEGGIANTI	646	<b>GIRANTI</b>	<b>671</b>	<b>MOTORINO D'AVVIAMENTO</b>	<b>671</b>
• PARAFIAMMA	646	<b>MOTORINO D'AVVIAMENTO</b>	<b>671</b>	<b>SHERWOOD</b>	<b>688</b>
• TUBO COMBUSTIBILE	646	<b>SENSORI</b>	<b>646</b>	<b>JABSCO</b>	<b>698</b>
<b>SENSORI</b>	<b>646</b>	• SENSORE DE TEMPERATURA OLIO	646	• GUIDE GIRANTI	698
• SENSORE TEMPERATURA OLIO	646	• SENSORE TEMPERATURA ACQUA	647	<b>FILTRAZIONE</b>	<b>701</b>
• SENSORE TPS	647	• SENSORE IAC	647	<b>INDICE REF</b>	<b>707</b>
• SENSORE IAC	647	• SENSORE TEMPERATURA SCAMBIATORE	647	<b>GARANTIA LIMITATA</b>	<b>714</b>
• SENSORE TEMPERATURA SCAMBIATORE	647	<b>ACCENSIONE</b>	<b>647</b>		
<b>ACCENSIONE</b>	<b>647</b>	• CALOTTE SPINTEROGENI	648		
• CALOTTE SPINTEROGENI	648	• PUNTINE	648		
• PUNTINE	648	• CONDENSATORE	648		
• CONDENSATORE	648	• ROTORI	649		
• ROTORI	649	• KIT DE ACCENSIONE	649		
• KIT DE ACCENSIONE	649	• SPINTEROGENI	649		
• SPINTEROGENI	649	<b>MODULO ACCENSIONE</b>	<b>650</b>		

**COMPONENTES  
PARTS  
COMPONENTI**

**FILTRO ACEITE  
OIL FILTER  
FILTRO OLIO**

Ref.	R.O. OEM
ALT023941	100-238-002

**MOTORES / ENGINES / MOTORI**  
VELVET DRIVE  
Abierto / Open / Aperto



Ref.	R.O. OEM
ALT340940	2001-238-001

**MOTORES / ENGINES / MOTORI**  
VELVET DRIVE  
Cerrado / Closed / Chiuso

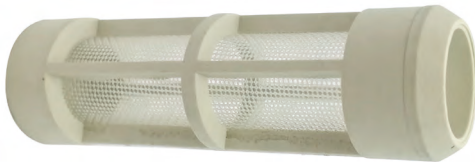

**KITS REPARACIÓN TRANSMISIÓN  
TRANSMISION REPAIR KIT  
KIT RIPARAZIONE TRASMISSIONE**

Ref.	R.O. OEM
A/P2277	A4867HA

**MOTORES / ENGINES / MOTORI**  
VELVET 71 & 72

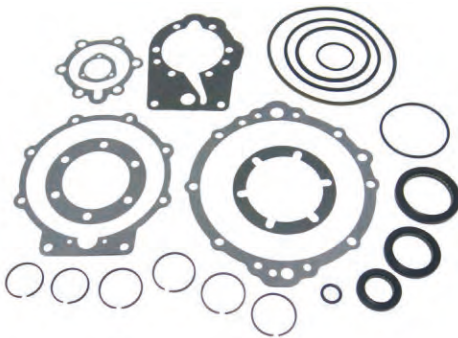

Ref.	R.O. OEM
A/P2278	

**MOTORES / ENGINES / MOTORI**  
VELVET 71 & 72  
Incluye discos  
Plates included  
Include dischi

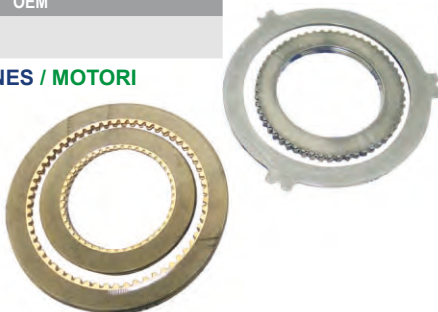

Ref.	R.O. OEM
A/P2279	1308-410-001

**MOTORES / ENGINES / MOTORI**  
V DRIVE

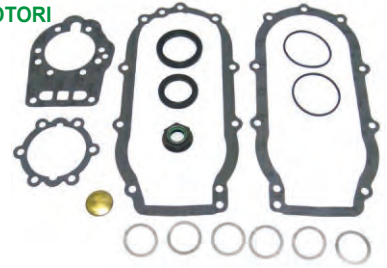

**DAMPER**

Ref.	R.O. OEM	Ø mm
REC855694	1004-650-006	169,16

**MOTORES / ENGINES / MOTORI**  
AS4-K2C  
-350 CID

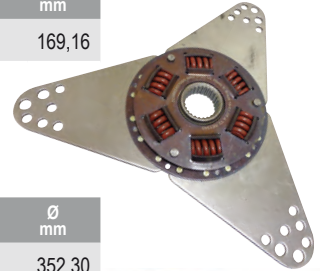

Ref.	R.O. OEM	Ø mm
ALTDA-101	1004-650-001	352,30



Ref.	R.O. OEM	Ø mm
ALTDA-102	1004-650-002	157,97

**MOTORES / ENGINES / MOTORI**  
AS4-K1C  
Volante delantero  
Forward flywheel  
Volano Anteriore



Ref.	R.O. OEM	Ø mm
ALTDA-107	1004-650-007	336,55

**MOTORES / ENGINES / MOTORI**  
AS7-K2C  
- 430 CID



Ref.	R.O. OEM	Ø mm
ALTDA-108	1004-650-008	157,97

**MOTORES / ENGINES / MOTORI**  
AS5-K2C  
-370 CID



**COLECTORES  
MANIFOLDS  
COLLETTORI**

Ref.	R.O. OEM
REC8N2250	1W6586 8N2250

**MOTORES / ENGINES / MOTORI**  
Para la mayoría motores 3208  
For most engines 3208  
Per la maggior parte dei motori 3208



**ENFRIADOR COMBUSTIBLE  
FUEL COOLER  
SCAMBIATORE DE  
COMBUSTIBILE**

Ref.	R.O. OEM
REC300-0539	

**MOTORES / ENGINES / MOTORI**  
C32



**BOMBA ASPIRACIÓN AGUA MARINA  
RAW MARINE WATER PUMPS  
POMPE ASPIRAZIONE ACQUA MARINA**

Ref.	R.O. OEM	ENTRADA INLET ENTRATA	SALIDA OUTLET USCITA
SHEP176X	7E.4115 FP-7E4115 9Y-1304	Ø 1 1/2"	Ø 1 3/4"

**MOTORES / ENGINES / MOTORI**  
Serie 3208



Ref.	R.O. OEM
SHEP1732C	170-6116 113-1109 152-8392

**MOTORES / ENGINES / MOTORI**  
C7 / C7  
Serie 3126

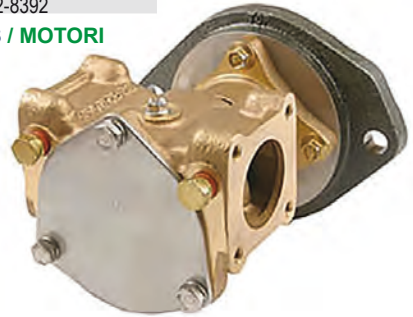

Ref.	R.O. OEM
SHEP1710C	4P-7168 7E-3268

**MOTORES / ENGINES / MOTORI**  
Serie 3116

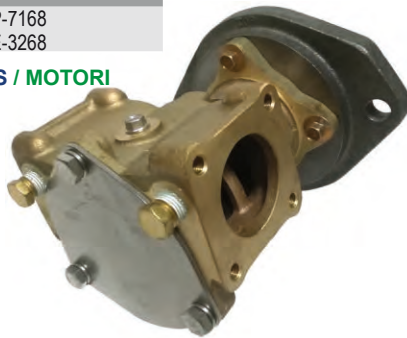

Ref.	R.O. OEM
SHEG2902X	196-8895

**MOTORES / ENGINES / MOTORI**  
C15 & C18  
Serie 3406E

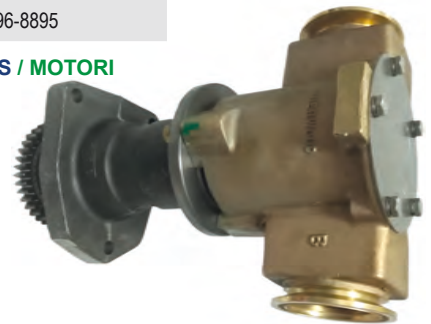

Ref.	R.O. OEM
SHEG2904X	197-1328 123-0471

**MOTORES / ENGINES / MOTORI**  
C12  
Serie 3196  
(Codos no incluidos)  
(Elbows not included)  
(Gomiti non incluso)

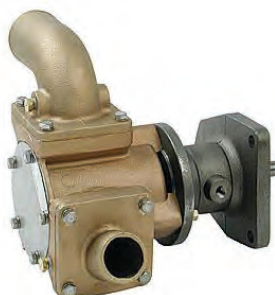

Ref.	R.O. OEM
REC7C3613	7C3613

**MOTORES / ENGINES / MOTORI**  
Serie 3412

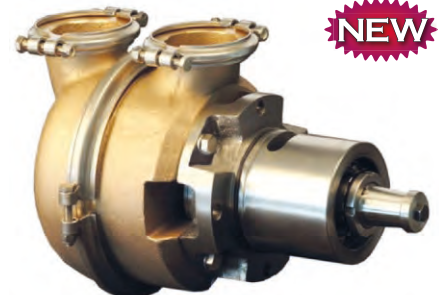

**CATERPILLAR**

Ref.	R.O. OEM
REC7C3614	7C3614
<b>MOTORES / ENGINES / MOTORI</b> Serie 3508	



Ref.	R.O. OEM	IMPULSOR IMPELLER GIRANTE
REC3N4851	3N4851	JAB17370-0001
<b>MOTORES / ENGINES / MOTORI</b> Serie 3406		



Ref.	R.O. OEM	IMPULSOR IMPELLER GIRANTE
REC5N9357	5N9357	CEF500135
<b>MOTORES / ENGINES / MOTORI</b> Serie 3304, 3306		



Ref.	R.O. OEM	ENTRADA INTLET ENTRATA	SALIDA OUTLET USCITA
SHEG3001X	147-7850 212-7264	Ø 3 <sup>3</sup> / <sub>4</sub> "	Ø 3 <sup>3</sup> / <sub>4</sub> "
<b>MOTORES / ENGINES / MOTORI</b> C30 & C32			



REF	IMPULSOR IMPELLER GIRANTE	KIT MENOR KIT MINOR KIT MINORE	KIT MAJOR KIT MAJOR KIT MAGGIORE
SHEP176X	SHE17000K	SHE23973	SHE23975
SHEP1710C	SHE17000K	SHE25123	SHE25121
SHEG2902X	SHE29000K	SHE25146	SHE25147
SHEP1732C	SHE17000K	SHE25123	SHE25121
SHEG2904X	SHE29000K	SHE25146	SHE25148
SHEG3001X	SHE30000K	SHE25017	SHE25154

**IMPULSORES  
IMPELLER  
GIRANTE**

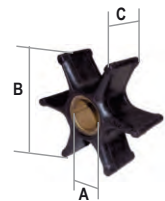

R.O. OEM	PALAS BLADES PALE	SHERWOOD	CEF	JOHNSON	JABSCO	RECMAR	MEDIDAS (mm) MEASURES (mm) MISURE (mm)		
							A	B	C
3N1906	8		CEF500106GT	JOH09-1028B		REC3841697	14,29	65	50,2
3N5895	8		CEF500177GT		JAB17018-0001	REC3593573	14,29	65,2	75,65
1L4774	9		CEF500105T	JOH09-1029B		REC836-0001	22,5	96	63,1
7E3022	9				JAB18786-0001		25,4	118	88,9
3N8449	10	SHE22000K	CEF500179GX				23,8	114,3	109,5
7C3286	10		CEF500114T		JAB17937-0001-P		14,29	65	50,1
7E0321 1W5664	12	SHE17000K	CEF500164T			REC17000K	20	84	73
1230492 1095324 1095327 1237985	12		CEF500182G			REC18000K	20,7	94,5	20,7
4L8470	12		CEF500145T	JOH09-814B		REC875697	22,5	95	88,5
5N9360	12		CEF500135	JOH09-819B		REC21730344	22,5	95	63,1
3N4859	12		CEF500152		JAB17370-0001		25,4	95	88,9



**FILTROS ACEITE**  
**OIL FILTERS**  
**FILTRI OLIO**

Ref.	R.O. OEM
REC21707134	1R-0658

**NEW**



Ref.	R.O. OEM	ROSCA THREAD FILETTO
REC847741	1R-0714	1 1/8" x 16 NPT

**NEW**



**MOTORES DE ARRANQUE**  
**STARTERS**  
**MOTORINO D'AVVIAMENTO**

Ref.	R.O. OEM	DIENTES TOOTH DENTI
REC128000-5720	128000-5720	12V 3.0kw 10

**MOTORES / ENGINES / MOTORI**  
Para mayoría motores 3114 - 3116  
For most engines 3114 - 3116  
Per la maggior parte dei motori 3114 - 3116

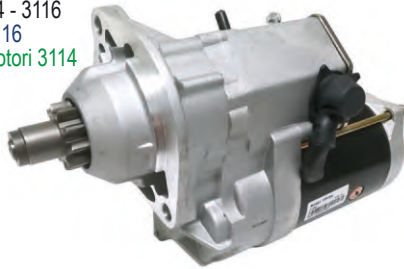

Ref.	R.O. OEM	DIENTES TOOTH DENTI
REC21323043	163-3361	12V 1.4Kw 9

**MOTORES / ENGINES / MOTORI**  
C2.2  
Serie 3024C, 3024T



**ALTERNADORES**  
**ALTERNATOR**  
**ALTERNATORE**

Ref.	R.O. OEM	12V 90A
REC8HC2023K	796351	

**MOTORES / ENGINES / MOTORI**  
Para mayoría motores 3280  
For most engines 3280  
Per la maggior parte dei motori 3280



**SILENTBLOCK**

Ref.	KG (LBS)	TORNILLO STUD PERNO	DISTANCIA ENTRE AGUJEROS MOUNT HOLE CENTERS DISTANZA TRA I FORI
RECDF238-M1	820 - 1000 (1800 - 2200)	3/4" - 16	127 mm

**MOTORES / ENGINES / MOTORI**  
Serie 3208 & 3304B (85-340 HP)



Ref.	KG (LBS)	TORNILLO STUD PERNO	DISTANCIA ENTRE AGUJEROS MOUNT HOLE CENTERS DISTANZA TRA I FORI
RECDF4408-4	1130 - 1270 (2500 - 2800)	1" - 14	127 mm

**MOTORES / ENGINES / MOTORI**  
Serie 3208+





CATERPILLAR

ÁNODOS DE ZINC  
ZINC ANODES  
ANODI IN ZINCO



REF	R.O. OEM	ROSCA TAPÓN PLUG THREAD PASSO TAPPO	Ø mm	LONGITUD LENGTH LUNGHEZZA	ROSCA THREAD PASSO
CM6L2016	6L2016	3/4"	22.26	20 mm	1/2 x 13
CME1	6L2280	3/8"	12.70	41 mm	3/8 x 16
CM6L2283	6L2283	1/4"	10.00	29 mm	5/16 x 18
CME8D	6L2284	1 1/4"	32.00	54 mm	3/4 x 10
CME-8	6L2285	1 1/4"	32.00	59 mm	3/4 x 10
CM6L2288	6L2288	1/2"	15.70	29 mm	7/16 x 14



SOLO ÁNODO  
ONLY ANODE  
SOLO ANODO



REF	R.O. OEM	kg / lbs	Ø mm	L mm	L1 mm	b
TEN02020		0,030 / 0.066	14	26	9	12 mm
TEN02021	6L2283	0,030 / 0.066	10	55	10	1/4" UNC
TEN02021/1	116-7011	0,015 / 0.033	9	35	10	1/4" UNC
TEN02022	6L2016	0,065 / 0.143	22	20	10	5/8" UNC
TEN02023	612289	0,105 / 0.231	16	76	13	3/8" UNC
TEN02024	6L2288	0,090 / 0.198	16	63	13	3/8" UNC
TEN02025	6L2284	0,035 / 0.077	14	33	12	5/16" UNC
TEN02026	6L2286	0,242 / 0.534	19	54	20	3/4" UNC
TEN02027	6L2280	0,033 / 0.073	12	40	10	3/8" UNC
TEN02028	7E5076	0,060 / 0.132	16	41	9	7/16" UNC
TEN02029	642281	0,035 / 0.077	12,5	38	10	7/16" UNC
TEN02029bis	6L3104	0,020 / 0.044	10	38	10	1/14" UNC

COMPLETO  
COMPLETE  
COMPLETO



REF	kg / lbs	Ø mm	L mm	a	c mm
TEN02021/1T	0,030 / 0.066	9	35	7/16" UNF	14
TEN02021T	0,045 / 0.099	10	55	1/4" gas conico	10
TEN02022T	0,145 / 0.320	22	20	3/8" gas	16
TEN02023T	1,155 / 0.342	16	76	1/2" gas conico	14
TEN02024T	0,135 / 0.298	16	63	1/2" gas	14
TEN02026T	0,495 / 1.091	19	54	1 1/4" gas conico	24
TEN02027T	0,060 / 0.132	12	40	3/8" gas conico	11
TEN02028T	0,120 / 0.265	16	41	1/2" gas conico	25
TEN02029BIS/T	0,040 / 0.088	10	38	1/4" gas	22
TEN02029T	0,065 / 0.143	12,5	38	3/8" gas conico	19



TAPÓN DE BRONCE  
BRASS PLUG  
TAPPO IN OTTONE

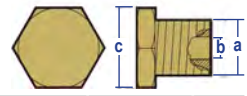

REF	R.O. OEM	kg / lbs	a	b	c mm
TEN02021TP	6L2282	0,015 / 0.165	1/4" gas conico (bspt)	1/4" UNC	10
TEN02023TP		0,040 / 0.088	1/2" gas conico (bspt)	3/8" UNC	14
TEN02024TP		0,040 / 0.088	1/2" gas (bspp)	3/8" UNC	14
TEN02026TP		0,280 / 0.617	1 1/4" gas conico (bspt)	3/4" UNC	24
TEN02027TP	6L2279	0,025 / 0.055	3/8" gas conico (bspt)	3/8" UNC	11
TEN02028TP		0,065 / 0.143	1/2" gas conico (bspt)	7/16" UNF	25
TEN02029TP	6L2279G	0,03 / 0.066	3/8" gas conico (bspt)	7/16" UNF	19

CHRIS-CRAFT

JUNTAS CULATA  
CYLINDER HEAD GASKET  
GUARNIZIONE TESTATA

Ref.	R.O. OEM
FEL17030	16.50-00250



MOTORES / ENGINES / MOTORI  
GM 305, 350 CID  
(5.0L / 5.7L)

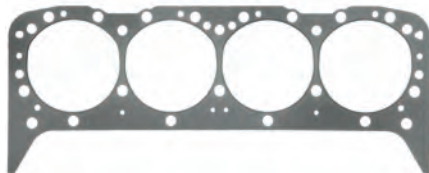

Ref.	R.O. OEM
FEL17046	16.50-00259



MOTORES / ENGINES / MOTORI  
GM 454 (7.4L) CID



**JUNTA CODO**  
**ELBOW GASKET**  
**GUARNIZIONE GOMITO**

Ref.	R.O. OEM
OSC0959	1650-05944
BACC47-1650-06022	1650-056022



OSC0959



BACC47-1650-06022

**PROTECTOR SALIDA ESCAPE**  
**EXHAUST PROTECTOR VALVE**  
**PROTEZIONE SCARICO**

Ref.	R.O. OEM
REC34765A2	3"
REC12644A1	4"
REC89260	5" 6"



REC34765A2



REC12644A1



REC89260

5" necesita 2 cortes de 45°  
5" requires two 45° cuts  
5" richiede due tagli a 45°

**BOMBA DE AGUA**  
**WATER PUMP**  
**POMPA ACQUA**

**BOMBA**  
**PUMP**  
**POMPA**

Ref.	R.O. OEM
SHEG30-2B	16.80-18346 1" NPT



**KITS BOMBA SHERWOOD**  
**KIT SHERWOOD PUMP**  
**KIT POMPA SHERWOOD**

Ref.	R.O. OEM
SHE10077K	16.80-90047



**JUNTA BOMBA**  
**PUMP GASKET**  
**GUARNIZIONE POMPA**

Ref.	R.O. OEM
REC27-34897	16.50-00078



Ref.	R.O. OEM
SHE10615K	16.80-90131



CHRIS-CRAFT

**BOMBAS COMBUSTIBLE**  
**FUEL PUMP**  
**POMPE BENZINA**

Ref.	R.O. OEM
REC86234A4	

**MOTORES / ENGINES / MOTORI**  
GM 4 & 6 cyl  
153, 181, 250, 224, 225

**NEW**



**JUNTA BOMBA**  
**PUMP GASKET**  
**GUARNIZIONE POMPA**

Ref.	R.O. OEM
REC27-34898	16.50-005756
REC27-34213	16.50-00074

**NEW**

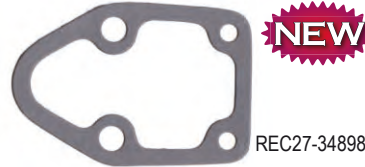

REC27-34898



REC27-34213

**FILTROS ACEITE**  
**OIL FILTERS**  
**FILTRI OLIO**

Ref.	R.O. OEM
REC35-06003	16.81-08746

**MOTORES / ENGINES / MOTORI**  
GM 153, 181, 250  
307G, 305K, 307K

**NEW**



Ref.	R.O. OEM
REC3850559	

**MOTORES / ENGINES / MOTORI**  
GM +283, 305, 307, 350, 454

**NEW**



Ref.	R.O. OEM
REC35-06007	16.81-06536

**MOTORES / ENGINES / MOTORI**  
Ford 302,351

**NEW**



# CARBURADORES CARBURETORS CARBURATORI

## KITS CARBURADOR CARBURETOR KITS KIT CARBURATORE

Ref.	R.O. OEM
REC823426A1	45334

**NEW**



Ref.	R.O. OEM
REC823427A1	

**NEW**

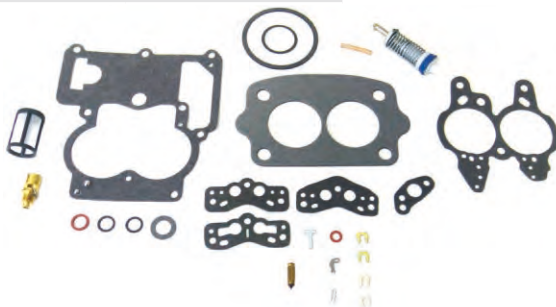

## BOYAS FLOATS GALLEGGIANTI

Ref.	R.O. OEM
REC1397-3327	
REC1397-2060	

**NEW**



**NEW**



REC1397-3327

REC1397-2060

## TUBO COMBUSTIBLE DE BOMBA A CARBURADOR FUEL TUBE FROM PUMP TO CARBURETOR TUBO CARBURANTE DA POMPA A CARBURATORE

Ref.	
REC18-8114	3/8" X 31" PTFE - 5/8"
REC18-8115	3/8" X 25" PTFE - 5/8"

**NEW**



# ENCENDIDO IGNITION ACCENSIONE

## TAPAS DISTRIBUIDOR DISTRIBUTOR CAPS CALOTTE SPINTEROGENI

Ref.	R.O. OEM
REC392-9766	

MOTORES / ENGINES / MOTORI  
PRESTOLITE V8  
Con tornillo / Screw on / con vite

**NEW**



Ref.	R.O. OEM
REC835702	18-5399

MOTORES / ENGINES / MOTORI  
PRESTOLITE V8

**NEW**



Ref.	R.O. OEM
REC12532	16.69-00100 F16900165

MOTORES / ENGINES / MOTORI  
MALLORY V8  
Tapa plana / Flat cap / Calotta piatta

**NEW**



Ref.	R.O. OEM
REC982209	16.69-00148

MOTORES / ENGINES / MOTORI  
MALLORY V8

**NEW**



Ref.	R.O. OEM
REC33765T	

MOTORES / ENGINES / MOTORI  
DELCO

**NEW**



Ref.	R.O. OEM
REC393-9459Q1	16.69-00052

MOTORES / ENGINES / MOTORI  
DELCO

**NEW**



**CHRIS-CRAFT**

**PLATINO  
POINT  
PUNTINE**

Ref.	R.O. OEM
REC8M6001219	



Ref.	R.O. OEM
REC34235T	16.69-00049



Ref.	R.O. OEM
REC391-5090	16.69-00039



**CONDENSADORES  
CONDENSERS  
CONDENSATORE**

Ref.	R.O. OEM
REC8M6001217	16.69-00040



Ref.	R.O. OEM
REC8M6001249	



Ref.	R.O. OEM
REC33662	41057 16.69-00050



Ref.	R.O. OEM
REC33706	



Ref.	R.O. OEM
REC64851	1869704



**ROTORES  
ROTORS  
ROTORI**

Ref.	R.O. OEM
REC3853801	



Ref.	R.O. OEM
REC89825302	16.69-00149



Ref.	R.O. OEM
REC834975	



Ref.	R.O. OEM
REC841243	16.69-00042



Ref.	R.O. OEM
REC58217	16.69-00051



**KITS DE ENCENDIDO  
TUNE UP KITS  
KIT ACCENSIONE**

Ref.	R.O. OEM
REC3423A1	



Ref.	R.O. OEM
REC391-5090Q1	

MOTORES / ENGINES / MOTORI  
Mallory 8 cyl.



Ref.	R.O. OEM
REC392-6324Q1	

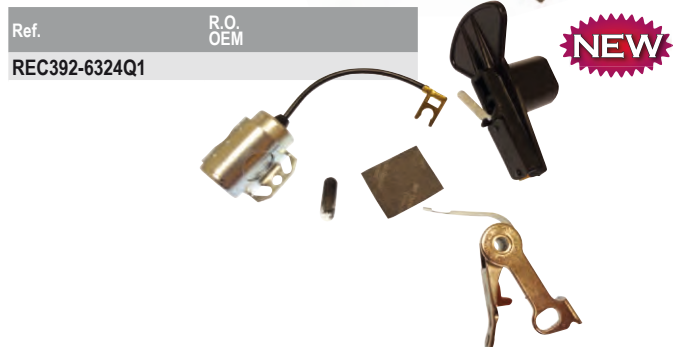

**DISTRIBUIDOR  
DISTRIBUTOR  
SPINTEROGENI**

Ref. R.O. OEM  
REC17177A1

MOTORES / ENGINES / MOTORI  
MALLORY YL624MW  
GM V8

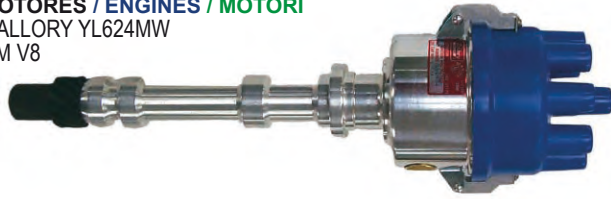

**NEW**

**JUNTA DISTRIBUIDOR  
DISTRIBUTOR GASKET  
GUARNIZIONE SPINTEROGENI**

Ref. R.O. OEM  
REC27-344861 16.50-00162

MOTORES / ENGINES / MOTORI  
GM V6, V8



**NEW**

**KITS DE CONVERSIÓN ELECTRÓNICO  
ELECTRONIC CONVERSION KITS  
KIT CONVERSIONE ELETTRONICO**

Ref. R.O. OEM  
REC26904

MOTORES / ENGINES / MOTORI  
Mallory YL o YD  
con rotación reloj y  
contrareloj. 8 cyl.  
For most Mallory V8  
distributors  
8 cilindri Mallory YL  
o YD con rotazione  
oraria e antioraria



**NEW**

Ref. R.O. OEM  
REC26902

MOTORES / ENGINES / MOTORI  
Para la mayoría de distribuidores Prestolite V8  
con tornillo en la tapa  
For most Prestolite V8 distributors with screw  
on cap  
Per al maggior parte degli spinterogeni  
Prestolite V8 con vite nella calotta.



**NEW**

Ref. R.O. OEM  
REC26903

MOTORES / ENGINES / MOTORI  
Prestolite V8



**NEW**

Ref. R.O. OEM  
REC26901

MOTORES / ENGINES / MOTORI  
Delco 6 cyl.



**NEW**

**BOBINAS ENCENDIDO  
IGNITION COILS  
BOBINE ACCENSIONE**

Ref. R.O. OEM  
REC1463-9382

Resistencia externa.  
Utilizar con encendido convencional.  
External resistor. Use with conventional  
ignition  
Resistenza esterna. Utilizzare con accensione  
convvenzionale



**NEW**

Ref. R.O. OEM  
REC300-00879

No usa resistencia externa.  
Utilizar con encendido Prestolite.  
Use without external resistor & Prestolite  
ignition  
Non utilizza resistenza esterna. Utilizzare cor  
spinterogeno Prestolite



**NEW**

CHRIS-CRAFT

MOTORES DE ARRANQUE  
STARTERS  
MOTORINO D'AVVIAMENTO

Ref.	R.O. OEM	
ARC50137	42090	12V

3 Tornillos de montaje (2 de 3/8", 1 de 5/16" Roscados)  
3 Bolt mount (two 3/8", one 5/16" threaded hole)  
3 Bulloni di supporto (2 da 3/8", 1 da 5/16")

Ref.	R.O. OEM	
ARC50138		12V

Contrarrotación o montaje en campana  
CCW Starter  
Controrotante o montato nella campana



Ref.	R.O. OEM		DIENTES TOOTH DENTI
PH140-0013	16.61-0042 16.61-0043	12V	9

MOTORES / ENGINES / MOTORI  
GM  
SAEJ1171, 225 (6 Cyl 3.7L)

Motor de arranque 4 en línea  
(Tornillos sujeción misma altura)  
Duty standard rotation 4 in line.  
In line mounting holes.  
4 in rete (viti di supporto parallele)



CRUSADER

JUNTAS MOTOR  
ENGINE GASKET  
GUARNIZIONE MOTORI

JUNTAS CULATA  
CYLINDER HEAD GASKET  
GUARNIZIONI TESTATA

Ref.	R.O. OEM	
FEL17010	33408	

FELPRO

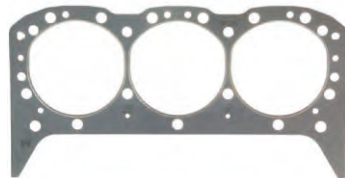

NEW

Ref.	R.O. OEM	
FEL17048	31137	

MOTORES / ENGINES / MOTORI  
502 (8.2L) CID  
7.4L

FELPRO



NEW

Ref.	R.O. OEM	
FEL17030	7057500	

MOTORES / ENGINES / MOTORI  
GM 305 (5.0L)  
350 (5.7L) CID

FELPRO

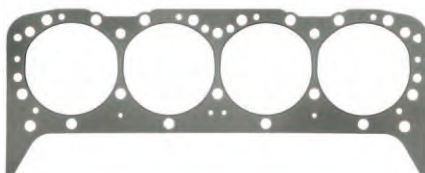

NEW

Ref.	R.O. OEM	
FEL17042	31136	

MOTORES / ENGINES / MOTORI  
454 (7.4L) CID GEN V

FELPRO



NEW

Ref.	R.O. OEM	
FEL17040	30266	

MOTORES / ENGINES / MOTORI  
GM 454 (7.4L) CID

FELPRO

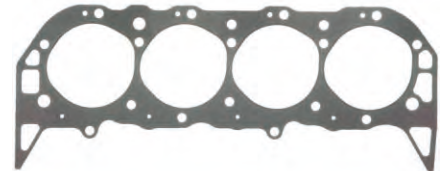

NEW

**JUNTAS TAPA BALANCINES**  
**VALVE COVER GASKET**  
**GUARNIZIONI COPERCHIO PUNTERIE**

Ref.	R.O. OEM
FEL17920	97686



MOTORES / ENGINES / MOTORI  
262 CID



Ref.	R.O. OEM
FEL17930	91351



MOTORES / ENGINES / MOTORI  
V-8



**JUNTAS DE ADMISIÓN**  
**INTAKE GASKET**  
**GUARNIZIONE DI ASPIRAZIONE**

Ref.	R.O. OEM
FEL17310	33393



MOTORES / ENGINES / MOTORI  
222 CID

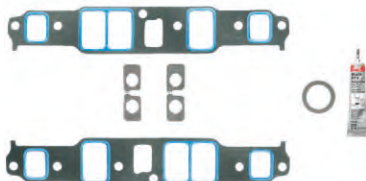

**JUNTAS COLECTOR ESCAPE**  
**EXHAUST MANIFOLD GASKET**  
**GUARN. COLLETTORE SCARICO**

Ref.	R.O. OEM	PARA COLECTORES FOR MANIFOLDS PER COLLETTORI
FEL17460		HOT20998



Ref.	R.O. OEM
REC27-99757	97498



MOTORES / ENGINES / MOTORI  
GM V6



Ref.	R.O. OEM
REC27-33395	96306



**JUNTA TAPA CADENA DISTRIBUCIÓN**  
**TIMING CHAIN COVER GASKET**  
**GUARNIZIONE CATENA CARTER DISTRIBUZIONE**

Ref.	R.O. OEM
REC27-14250	20129

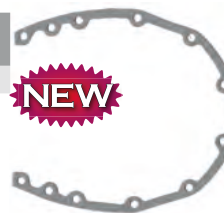

**COLECTORES ESCAPE**  
**EXHAUST MANIFOLDS**  
**COLLETTORI SCARICO**

**GM SMALL BLOCK V8 5.0 & 5.7L,**  
**220, 270**

Ref.	R.O. OEM	KIT TORNILLERÍA HARDWARE KIT BULLONERIA	R.O. OEM
HOT20925	97752 96120	Estribor Stbd Tribordo	OSC775-MK 96120
HOT20926	97753 96121	Babor Port Babordo	HOT20775-MK  96121

MOTORES / ENGINES / MOTORI  
5.0 & 5.7L, 220, 270



OSC775-MK  
HOT20775-MK

**GM BIG BLOCK V8 7.4L & 8.2L,**  
**454XL**

Ref.	R.O. OEM	KIT TORNILLERÍA HARDWARE KIT BULLONERIA	R.O. OEM
HOT20929	97992 97114	Estribor Stbd Tribordo	97114 97992
HOT20933	97993 97115	Babor Port Babordo	HOT20799-MK  97115 97993

MOTORES / ENGINES / MOTORI  
7.4 & 8.2L



HOT20799-MK



**CRUSADER**

**GM SMALL BLOCK V8 5.0 & 5.7L,  
CM305, CM350XL & CM350HT**

Ref.	R.O. OEM	KIT TORNILLERÍA HARDWARE KIT BULLONERIA	R.O. OEM
HOT20982	98125	HOT20982-MK	<b>NEW</b>

**MOTORES / ENGINES / MOTORI**  
7.4 & 8.2L  
454XL & 502XL

**NEW**

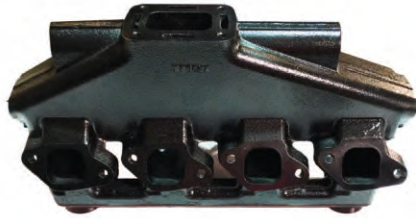

**NEW**



HOT20982-MK



**GM BIG BLOCK V8 7.4 & 8.2L,  
454XL & 502XL**

Ref.	R.O. OEM	KIT TORNILLERÍA HARDWARE KIT BULLONERIA	R.O. OEM
REC98243	98243	OSC8243-MK	



OSC8243-MK

**CODOS, SUPLEMENTOS Y KITS  
ELBOWS, RISERS & KITS  
GOMITI, DISTANZIALI E KIT**

**GM SMALL BLOCK V8 5.0 & 5.7L, CM305, CM350XL & CM350HT  
GM BIG BLOCK V8 7.4 & 8.2L, 454XL & 502XL**

**CODO ESCAPE  
EXHUST ELBOW  
GOMITO SCARICO**

Ref.	R.O. OEM	KIT TORNILLERÍA HARDWARE KIT BULLONERIA	JUNTA CODO ELBOW GASKET GUARNIZIONE GOMITO
HOT20938	98126	HOT20982-MK	OSC9015G

**MOTORES / ENGINES / MOTORI**  
V8. 283, 305, 307, 327 & 350

**NEW**



OSC9015G

**NEW**

HOT20982-MK



**SUPLEMENTO 4"  
4" RISER  
PROLUNGA 4"**

Ref.	R.O. OEM	KIT TORNILLERÍA HARDWARE KIT BULLONERIA
HOT30984	98128	OSC8128-MK HOT30984-MK

**MOTORES / ENGINES / MOTORI**  
V8 283, 305, 307, 327 & 350

**NEW**



**NEW**

OSC8128-MK  
HOT30984-MK



GM SMALL BLOCK V8 5.0 & 5.7L, 220, 270  
GM BIG BLOCK V8 7.4L & 8.2L, 454XL

SUPLEMENTO ESCAPE 8"  
8" EXHAUST RISER  
PROLUNGA SCARICO 8"

Ref.	R.O. OEM	KIT TORNILLERIA HARDWARE KIT BULLONERIA
HOT20916	97169	OSC7169-MK HOT20916-MK <b>NEW</b>



**NEW**

OSC7169-MK  
HOT20916-MK

SUPLEMENTO ESCAPE 4"  
4" EXHAUST RISER  
PROLUNGA SCARICO 4"

Ref.	R.O. OEM	KIT TORNILLERIA HARDWARE KIT BULLONERIA
HOT20927	97772	OSC7772-MK HOT20927-MK



**NEW**

OSC7772-MK  
HOT20927-MK

CODO ESCAPE  
EXHUST ELBOW  
GOMITO SCARICO

Ref.	R.O. OEM		KIT TORNILLERIA HARDWARE KIT BULLONERIA
HOT20934	<b>NEW</b> 98068	3"	HOT26562-MK
HOT20928	<b>NEW</b> 96560	4"	
HOT20918	<b>NEW</b> 97924	4"	
HOT20918	<b>NEW</b> 97386		



HOT20934



HOT20928



Codo revestido  
Jacketed elbow  
Gomito rivestito

HOT20918

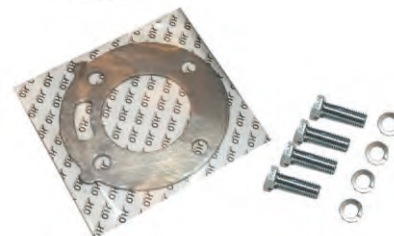

HOT26562-MK

JUNTA PARA CODO HOT20928  
GASKET FOR ELBOW HOT20928  
GUARNIZIONE PER GOMITO HOT20928

Ref.	R.O. OEM
REC96562	96562

MOTORES / ENGINES / MOTORI  
V6 - V8



**CRUSADER**

**CODO ESCAPE GIRATORIO  
EXHUST ELBOW SWIVEL  
GOMITO SCARICO GIRATORIO**

Ref.	R.O. OEM	
OSC7387	97387	3"
OSC7624	97624	4"



**PROTECTOR SALIDA ESCAPE  
EXHAUST PROTECTOR VALVE  
PROTEZIONE SCARICO**

Ref.	R.O. OEM	
REC34765A2		3"
REC12644A1		4"
REC89260		5" 6"



REC34765A2

REC12644A1



REC89260

5" necesita 2 cortes de 45°  
5" requires two 45° cuts  
5" richiede due tagli a 45°

**JUNTA CODO  
ELBOW GASKET  
GUARNIZIONE GOMITO**

Ref.	R.O. OEM	
REC96216	96216	

**MOTORES / ENGINES / MOTORI**  
V6 - V8



**BOMBA DE CIRCULACIÓN BLOQUE  
BLOCK CIRCULATING PUMP  
POMPA DI RICIRCOLO DI BLOCCO**

Ref.	R.O. OEM	
PH600-0002	67859	
	17670	
	811573	
	30103	

**MOTORES / ENGINES / MOTORI**

Bidireccional. Para bloques GM grandes con tapa del distribuidor de acero estampado.  
Bi-directional. For big block GM engines with stamped steel timing covers.  
Bidirezionale. Per motori GM di grandi dimensioni con coperchi di distribuzione in acciaio stampato.



Ref.	R.O. OEM	
PH600-0006		

**MOTORES / ENGINES / MOTORI**

Bidireccional.  
Bi-directional.  
Bidirezionale.



Ref.	R.O. OEM	
PH600-0005	20318	
	7142520	

**MOTORES / ENGINES / MOTORI**

GM V-6 y V8 de bloque pequeño.  
GM V-6 & small blocks V8 engines.  
GM V-6 e piccoli blocchi V8 motori

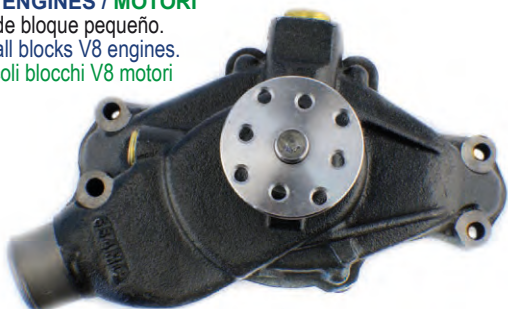

**BOMBA ASPIRACIÓN AGUA MARINA**  
**RAW MARINE WATER PUMPS**  
**POMPE ASPIRAZIONE ACQUA MARINA**

Ref.	R.O. OEM
SHEE35	97179 1" NPT



Ref.	R.O. OEM
REC3860703	40070

MOTORES / ENGINES / MOTORI  
V6 & V8



Ref.	R.O. OEM
SHEP1014	40050 1 1/4" NPT



**KITS BOMBA SHERWOOD**  
**KIT SHERWOOD PUMP**  
**KIT POMPA SHERWOOD**

Ref.	R.O. OEM
SHE09959K	1003026 Ø 2 7/16" Lat. 1 1/4"

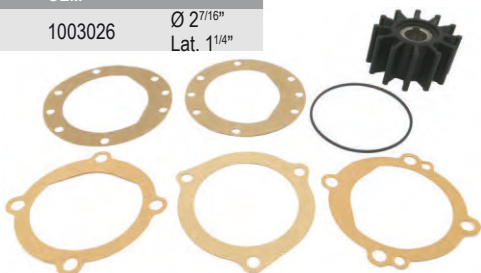

Ref.	R.O. OEM
CEF500103T	1003062 1003026 22212 Ø 2 7/16" Lat. 1 1/4"



Ref.	R.O. OEM
REC10615K	20300
SHE10615K	20310
CEF500120T	R061017



**NEW**

Ref.	R.O. OEM
REC3854286	1003026 22212



**NEW**

**KIT RETÉN**  
**KIT SEAL**  
**KIT PARAOLIO**

Ref.	R.O. OEM
SHE10927	20309



**NEW**

Ref.	R.O. OEM
SHE12859	40057



**NEW**

**RACORD MANGUERA CODO**  
**WATER FITTING**  
**RACCORDO T UBO GOMITO**

Ref.	R.O. OEM
REC18-8112	1 1/4"



**COJINETE BOMBA SHERWOOD**  
**BEARING SHERWOOD PUMP**  
**CUSCINETTO POMPA SHERWOOD**

Ref.	R.O. OEM
SHE4257	20292



**CRUSADER**

**BOMBAS COMBUSTIBLE  
FUEL PUMP  
POMPE BENZINA**

Ref.	R.O. OEM
REC3855276	981650



**MOTORES / ENGINES / MOTORI**  
GM V8, 305, 307, 350, 400  
(5.25 - 6.5 PSI)

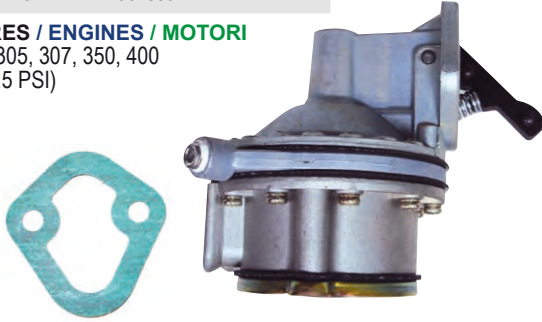

Ref.	R.O. OEM
REC62092T	982063



**MOTORES / ENGINES / MOTORI**  
FORD V8, 302



**TERMOSTATO  
THERMOSTAT  
TERMOSTATO**

**TERMOSTATO  
THERMOSTAT  
TERMOSTATO**

Ref.	R.O. OEM	60° C
BACR-29-96319	96319	60° C



Ref.	R.O. OEM	70° C
REC8M0091470	97895	70° C

Sólo para circuitos Agua dulce  
Thermostat for fresh water cooling only  
Solo per circuiti ad acqua dolce



Ref.	R.O. OEM	70° C
REC76270T	96358	70° C



Sólo para circuitos Agua dulce  
Thermostat for fresh water cooling only  
Solo per circuiti ad acqua dolce



**KIT TERMOSTATO  
THERMOSTAT KIT  
KIT TERMOSTATO**

Ref.	R.O. OEM	60° C
REC97361	97361	60° C



**FILTROS Y ELEMENTOS  
FILTERS AND ELEMENTS  
FILTRI E RACCORDI**

**FILTRO SEPARADOR DE AGUA  
WATER SEPARATING FUEL FILTER  
FILTRO SEPARATORE ACQUA-BENZINA**

Ref.	R.O. OEM
REC35-8M0061975	98041



**FILTROS COMBUSTIBLE  
FUEL FILTER  
FILTRO BENZINA**

Ref.	R.O. OEM
REC982230	91606



# CRUSADER

RECAMBIO PARA CARBURADORES ROCHESTER 2 & 4 BBL  
ELEMENT FOR ROCHESTER 2 & 4 BBL CARBURETORS  
CARTUCCIA PER CARBURATORI ROCHESTER 2 E 4 BBL

Ref.	R.O. OEM
REC93568	



Ref.	R.O. OEM
REC35-06007	9002514

MOTORES / ENGINES / MOTORI  
Ford



## FILTROS ACEITE OIL FILTERS FILTRI OLIO

Ref.	R.O. OEM
REC35-06003	201104



MOTORES / ENGINES / MOTORI  
GM + SS330 Remote Mount



Ref.	R.O. OEM
REC3850559	201104

MOTORES / ENGINES / MOTORI  
GM + SS330 Remote Mount



Ref.	R.O. OEM
REC3517857	

MOTORES / ENGINES / MOTORI  
220, 300, 320, 325 Remote Mount



# CARBURADORES CARBURETORS CARBURATORI

## KITS CARBURADOR CARBURETOR KITS KIT CARBURATORE

Ref.	R.O. OEM
REC841994	

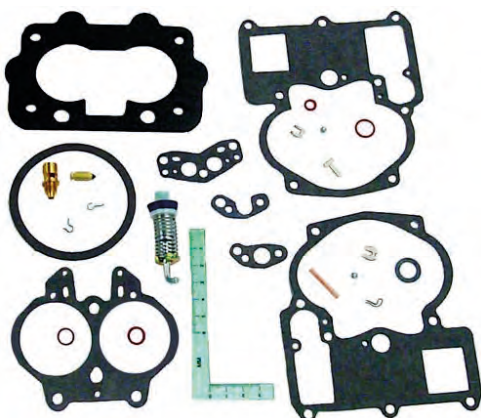

Ref.	R.O. OEM
REC823427A1	

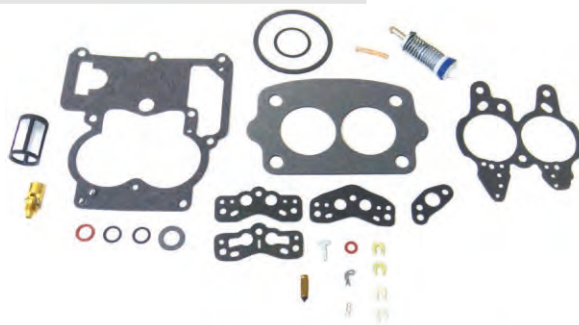

## GUÍA KITS CARBURADOR Y BOYAS CARBURETOR & FLOATS APPLICATION GUIDA KIT CARBURATORE E GALLEGGIANTI

Ref.	R.O. OEM
REC823426A1	45334

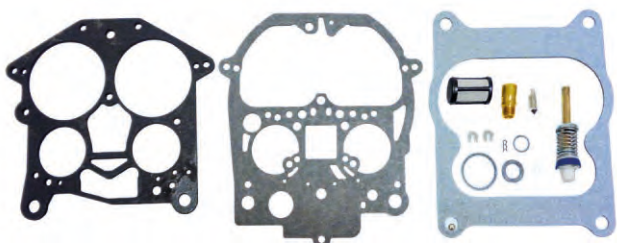

CYL.	Modelo Model Modello	MFG. CODE	CARB. MOD.	CARB. NUM.	KIT	BOYAS FLOAT GALLEGGIANTI
4	153" 2.5L	R-2	2GC	7025082 7028086	REC823427A1	REC1397-2060
6"	225" 3.7L	R-2	2GC	7025181	REC823427A1	
8"	283" 4.6L 327 5.3L	R-2	2GC	7024185	REC823427A1	
8"	305" 5.0L	R-2	5GV	17057134	REC841994	REC3302-9031
8"	350" 5.7L 454" 7.4L	R-4	4MV	17059293 17082403	REC823426A1	REC1397-3327
8"	427" 7.0L	R-4	4MV	7027081 7028282	REC823426A1	REC1397-3327

**CRUSADER**

**BOYAS  
FLOATS  
GALLEGGIANTI**

Ref.	R.O. OEM
REC1397-3327	
REC1397-2060	45303
REC3302-9031	

**NEW**



REC1397-2060

**NEW**



REC1397-3327

**NEW**



REC3302-9031

**APAGALLAMAS  
FLAME ARRESTORS  
PARAFIAMMA**

Ref.	R.O. OEM
REC85785A2	97595 97214

**NEW**

**MOTORES / ENGINES / MOTORI  
V-8**



Ref.	R.O. OEM
REC805298A1	33628

**NEW**

**MOTORES / ENGINES / MOTORI  
Hi-Performance**



**TUBO COMBUSTIBLE  
DE BOMBA A CARBURADOR  
FUEL TUBE  
FROM PUMP TO CARBURETOR  
TUBO CARBURANTE  
DA POMPA A CARBURATORE**

Ref.	R.O. OEM	
REC18-8114		3/8" X 31" PTFE - 5/8"
REC18-8115		3/8" X 25" PTFE - 5/8"

**NEW**



**SENSORES  
SENSORS  
SENSORI**

**TEMPERATURA ACEITE  
OIL TEMPERATURE  
TEMPERATURA OLIO**

Ref.	R.O. OEM	HILO THREAD FILO	TERMINAL
REC8M0068784	700425	1/8 - 27	10 - 31



**NEW**

**TEMPERATURA AGUA  
WATER TEMPERATURE  
TEMPERATURA ACQUA**

Ref.	R.O. OEM	
REC97258A1	700427	1/2"-14NPT

**NEW**



**SENSOR TPS**  
**TPS SENSOR**  
**SENSORE TPS**

Ref.	R.O. OEM
REC805226A1	47032

**NEW**



**SENSOR IAC**  
**IAC SENSOR**  
**SENSORE IAC**

Ref.	R.O. OEM
REC3855194	47033

**NEW**



**TEMPERATURA ENFRIADOR**  
**COOLANT TEMPERATURE**  
**TEMPERATURA SCAMBIATORE**

Ref.	R.O. OEM
REC3850397	47002

**NEW**



**ENCENDIDO**  
**IGNITION**  
**ACCENSIONE**

**TAPAS DISTRIBUIDOR**  
**DISTRIBUTOR CAPS**  
**CALOTTE SPINTEROGENI**

Ref.	R.O. OEM
REC12532	12532

**MOTORES / ENGINES / MOTORI**  
MALLORY V8  
Tapa plana / Flat cap / Calotta piatta



Ref.	R.O. OEM
REC393-4988	3000121

**NEW**



Ref.	R.O. OEM
REC33765T	

**NEW**



Ref.	R.O. OEM
REC982209	20222

**MOTORES / ENGINES / MOTORI**  
MALLORY V8



Ref.	R.O. OEM
REC835702	41052

**MOTORES / ENGINES / MOTORI**  
PRESTOLITE V8  
Con clip / Clip on / Con clip



Ref.	R.O. OEM
REC392-9086T	41069

**MOTORES / ENGINES / MOTORI**  
PRESTOLITE V6



Ref.	R.O. OEM
REC392-9766	41076

**MOTORES / ENGINES / MOTORI**  
PRESTOLITE V8  
Con tornillo / Screw on / con vite





**CRUSADER**

Ref.	R.O. OEM
REC3854260	

**MOTORES / ENGINES / MOTORI**  
4 cy



Ref.	R.O. OEM
REC3854331	

**MOTORES / ENGINES / MOTORI**  
DELCO V6  
Encendido electrónico / Electronic ignition /  
Accessione elettronico



Ref.	R.O. OEM
REC3854548	38070

**MOTORES / ENGINES / MOTORI**  
DELCO V8  
Encendido electrónico / Electronic ignition /  
Accessione elettronico



Ref.	R.O. OEM
REC33708	12528

**MOTORES / ENGINES / MOTORI**  
V8



**CONDENSADORES  
CONDENSERS  
CONDENSATORE**

Ref.	R.O. OEM
REC8M6001217	12530



**NEW**

Ref.	R.O. OEM
REC8M6001249	



**NEW**

Ref.	R.O. OEM
REC33662	41057 705787



**NEW**

Ref.	R.O. OEM
REC33706	12526



**NEW**

**PLATINO  
POINT  
PUNTINE**

Ref.	R.O. OEM
REC34235T	

**NEW**



Ref.	R.O. OEM
REC391-5090	20117

**NEW**



Ref.	R.O. OEM
REC8M6001219	41058

**NEW**



Ref.	R.O. OEM
REC58033	3000124

**NEW**



**ROTORES  
ROTORS  
ROTORI**

Ref.	R.O. OEM
REC3853801	41089 41074

**NEW**



Ref.	R.O. OEM
REC834975	41059

**NEW**



Ref.	R.O. OEM
REC89825302	20223

**NEW**



Ref.	R.O. OEM
REC841243	12531 1003318

**NEW**



Ref.	R.O. OEM
REC65864	3000122



Ref.	R.O. OEM
REC3854261	3854261



Ref.	R.O. OEM
REC3854311	

**MOTORES / ENGINES / MOTORI**  
DELCO V6



Ref.	R.O. OEM
REC3854549	38071

**MOTORES / ENGINES / MOTORI**  
V8  
Para tapa / For cap / Per calotta: REC3854548



Ref.	R.O. OEM
REC58217	



**KITS DE ENCENDIDO**  
**TUNE UP KITS**  
**KIT ACCENSIONE**

Ref.	R.O. OEM
REC3423A1	



Ref.	R.O. OEM
REC391-5090Q1	20117 + 12530 + 20223

**MOTORES / ENGINES / MOTORI**  
Mallory V8



Ref.	R.O. OEM
REC392-6325Q1	41058 + 41057 + 41059

**MOTORES / ENGINES / MOTORI**  
V8 Prestolite  
Clip en la tapa  
Clip on cap  
Clip nella Calotta



Ref.	R.O. OEM
REC392-6324Q1	41058 + 41057 + 41074

**MOTORES / ENGINES / MOTORI**  
Prestolite V6 & V8



**DISTRIBUIDORES**  
**DISTRIBUTORS**  
**SPINTEROGENI**

Ref.	R.O. OEM
REC17177A1	37061

**MOTORES / ENGINES / MOTORI**  
MALLORY V8 GM



Ref.	R.O. OEM	KIT
REC392-6316		REC391-5090Q1

**MOTORES / ENGINES / MOTORI**  
MALLORY YL512CV  
Ford 302 CID V8



Ref.	R.O. OEM
REC817377	

**MOTORES / ENGINES / MOTORI**  
181 RX  
Delco est ignition



**CRUSADER**

Ref.	R.O. OEM
REC807964A1	

**NEW**

**MOTORES / ENGINES / MOTORI**  
V6



Ref.	R.O. OEM
REC805222A1	RA107039E

**NEW**

**MOTORES / ENGINES / MOTORI**  
V8 262, 454, 502 except 384/409

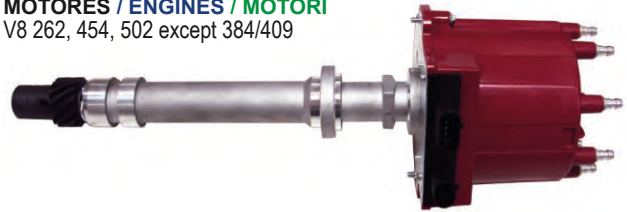

**KITS DE CONVERSIÓN ELECTRÓNICO**  
**ELECTRONIC CONVERSION KITS**  
**KIT CONVERSIONE ELETTRONICO**

- Sustituyen condensadores y contactos por componentes electrónicos.
- Usa bobina, tapa y rotor standard.
- De fácil instalación, una pieza y dos cables.
- Precisión entre 1/4" calibrado de 0 a 8000 rpm.
- To substitute condensers for electronic devices
- Uses standard coil, cap & rotor
- Easy installation; one piece, two cables.
- Precisely calibrated between 1/4" from 0 to 8000
- Sostituiscie condensatori e contatti per componenti elettronici.
- Utilizza bobina, calotta e rotore standard.
- Facile installazione, un pz e due cavi.
- Precisione 1/4" calibrato da 0 a 8000.

Ref.	R.O. OEM
REC26904	

**NEW**

**MOTORES / ENGINES / MOTORI**  
Mallory YL o YD con rotación reloj y contrareloj. 8 cyl.  
For most Mallory V8 distributors  
8 cilindri Mallory YL o YD con rotazione oraria e antioraria



Ref.	R.O. OEM
REC26902	

**NEW**

**MOTORES / ENGINES / MOTORI**  
Para la mayoría de distribuidores Prestolite V8 con tornillo en la tapa  
For most Prestolite V8 distributors with screw on cap  
Per al maggior parte degli spinterogeni Prestolite V8 con vite nella calotta.



Ref.	R.O. OEM
REC26901	

**NEW**

**MOTORES / ENGINES / MOTORI**  
Delco 6 cyl.



Ref.	R.O. OEM
REC26903	

**NEW**

**MOTORES / ENGINES / MOTORI**  
Prestolite V8



**MÓDULO ENCENDIDO**  
**IGNITION MODULE**  
**MODULO ACCENSIONE**

Ref.	R.O. OEM
REC3854001	

**NEW**

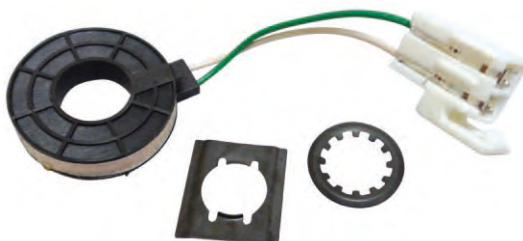

Ref.	R.O. OEM
REC3854003	7243110

**NEW**

**MOTORES / ENGINES / MOTORI**  
4, 6, 8 cyl



# BOBINAS ENCENDIDO IGNITION COILS BOBINE ACCENSIONE

Ref.	R.O. OEM
REC1463-9382	37068 51080

Resistencia externa.  
Utilizar con encendido convencional.  
External resistor. Use with conventional ignition  
Resistenza esterna. Utilizzare con accensione convenzionale



Ref.	R.O. OEM
REC3854002	7243200

MOTORES / ENGINES / MOTORI  
4 cyl V8  
3.0L (1991+)  
5.7 & 7.4 efi (1995+)

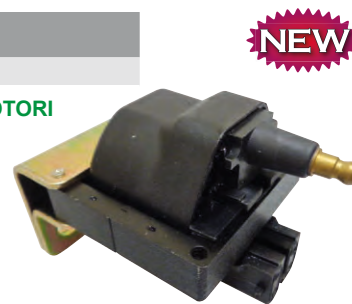

Ref.	R.O. OEM
REC300-00879	

MALLORY

No usa resistencia externa.  
Utilizar con encendido Prestolite.  
Use without external resistor & Prestolite ignition  
Non utilizza resistenza esterna. Utilizzare con spinterogeno Prestolite



Ref.	R.O. OEM
REC3854161	3854161

MOTORES / ENGINES / MOTORI  
FORD



## JUEGOS DE CABLE PARA BUJÍAS DE ALTO RENDIMIENTO HD SPARK PLUG WIRE SET KIT CAVI CANDELE ALTE PRESTAZIONI

- Núcleo del cable de Kevlar de 8 mm antimagnético
- Funda de silicona amarilla
- Terminales bujías con muelle de acero inox
- Terminal del Distribuidor de Cobre
- Terminales Bobina
- Silicona resistente a altas temperaturas
- Garantía de 5 años

- Antimagnetic Kevlar core
- Yellow silicone boot & jacket
- SS snaplock
- Brass distributor terminal
- Coil terminals
- High resistant silicone
- 5 year warranty

- Nucleo del cavi de Kevlar da 8 mm antimagnetico
- Fodera insilicone gialla
- Terminali candele con molle di acciaio inox.
- Terminale latospinteorgeno in rame
- Terminali Bobina
- Silicone resistente alle alte temperature
- Garanzia 5 anni

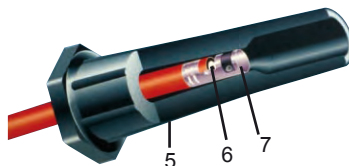
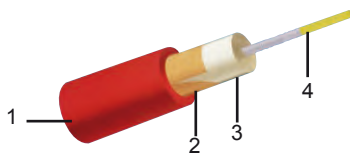

Nº	Descripción	Description	Descrizione
1	Camisa de silicona de 8 mm.	8 mm silicone jacket	Guaina in silicone da 8 mm
2	Latex resistente altas temperaturas	heat resistant latex	Latex resistente alle alte emperature
3	Acero inox	Stainless Steel	Acciaio inox
4	Núcleo de Kevlar	Kevlar core	Nucleo de Kevlar
5	Capuchón de silicona	silicone jacket	Cappucio in silicone
6	Trenzado fibra	Fiberglass braiding	Fibra di vetro
7	Terminal de acero inox	Stainless Steel terminal	Terminale in acciaio inox

Ref	R.O. OEM	MODELO MOELLO	ARRANQUE CONVENCIONAL IGNITION CONVENTIONAL AVVIAMENTO CONVENZIONALE	ARRANQUE ELECTRÓNICO IGNITION ELECTRONIC AVVIAMENTO ELETTRONICO	SERIES XL	CYL
REC15-604		262/4.3L	✓			6
REC15-601		262/4.3L		✓		6
REC15-801		305/5.0L	✓			8
REC15-801		350/5.7L	✓			6
REC15-805		350/5.7L		✓		8
REC15-801		454/7.4L	✓			8
MAG15-803		454/5.7L			✓	8
REC15-801		502/8.2L	✓			8
MAG15-803		502/8.2L			✓	8

MOTORES DE ARRANQUE  
STARTERS  
MOTORINO D'AVVIAMENTO

Ref.	R.O. OEM		DIENTES TOOTH DENTI
PH140-0022	42090		9
	RA122008	12V 1.4kw	
	1109484		
	19010617		

MOTORES / ENGINES / MOTORI

170, 185, 200, 225, 230, 283, 305,  
307, 327, 348, 350, 364, 409, 427,  
454, 496



Ref.	R.O. OEM	
ARC50137	42090	12V

3 Tornillos de montaje (2 de 3/8", 1 de 5/16" Roscados)  
3 Bolt mount (two 3/8", one 5/16" threaded hole)  
3 Bulloni di supporto (2 da 3/8", 1 da 5/16")

Ref.	R.O. OEM	
ARC50138		12V

Contrarrotación o montaje en campana  
CCW Starter  
Controrotante o montato nella campana



Ref.	R.O. OEM		DIENTES TOOTH DENTI
PH140-0013	1 107399	12V	9
	1109486		

MOTORES / ENGINES / MOTORI

153, 229, 305, 350, 454

Motor de arranque 4 en línea  
(Tornillos sujeción misma altura)  
Duty standard rotation 4 in line.  
In line mounting holes.  
4 in rete (viti di supporto parallele)



Ref.	R.O. OEM		DIENTES TOOTH DENTI
PH140-0022-CCW	42091	12V 1.4kw	9
	RA122009		
	1109485		
	9000888		
	19010615		

Contrarrotación o montaje en campana  
CCW Starter

Controrotante o montato nella campana



Ref.	R.O. OEM		DIENTES TOOTH DENTI
PH140-0017-D	RA122015	12V 1.4kw	11

MOTORES / ENGINES / MOTORI

496



Ref.	R.O. OEM		DIENTES TOOTH DENTI
PH140-0015	1109482	12V	9

MOTORES / ENGINES / MOTORI

262, 454



EXTENSOR DE SOLENOIDE PARA  
TERMINALES  
SOLENOID EXTENSOR FOR TERMINALS  
PROLUNGA TERMINALE PER SOLENOIDE

Ref.	R.O. OEM
PH365-0006	



COLECTORES  
MANIFOLDS  
COLLETTORI

Ref.	R.O. OEM
	3922122
REC3922122	4020066
	4019951

MOTORES / ENGINES / MOTORI  
6B, 6BT & 6BTA



BOMBA DE AGUA MARINA  
MARINE WATER PUMP  
POMPA ACQUA MARINA

Ref.	R.O. OEM	ENTRADA INLET ENTRATA	SALIDA OUTLET USCITA	IMPULSOR IMPELLER GIRANTE
DJC0819	3912139			
SHEP1722C	3922589	Ø 2"	Ø 1 3/4"	REC17000K

MOTORES / ENGINES / MOTORI  
6B & 6C 270-450 HP (8.3L)

**NEW**



Ref.	R.O. OEM	ENTRADA INLET ENTRATA	SALIDA OUTLET USCITA	IMPULSOR IMPELLER GIRANTE
DJC0820	3912019			
SHEM71	3010336 3278137 3907458	Ø 1/4"	Ø 1/4"	REC10615K

MOTORES / ENGINES / MOTORI  
4 cyl B Series 210 HP  
(3.9L)  
4B  
4BT3.9  
6BT5.9

**NEW**



Ref.	R.O. OEM	IMPULSOR IMPELLER GIRANTE
DJC1730	3866493	
SHEP1730C	3897194	REC17000K

MOTORES / ENGINES / MOTORI  
6CTA 8.3M  
6CTA 5.9  
(270 - 450 HP) (5.9 & 8.3L)  
Codos con brida  
Flanged Elbows  
Gomiti con fascetta

**NEW**



Ref.	R.O. OEM	ENTRADA INLET ENTRATA	SALIDA OUTLET USCITA	IMPULSOR IMPELLER GIRANTE
DJC004	3010336 3278137	Ø 1/2"	Ø 1/2"	CEF500135

MOTORES / ENGINES / MOTORI  
NH220  
NH250  
V555  
NT855

**NEW**



Ref.	R.O. OEM	ENTRADA INLET ENTRATA	SALIDA OUTLET USCITA	IMPULSOR IMPELLER GIRANTE
DJC0830	3912962	Ø 1 1/2"	Ø 1 1/2"	REC15000K
SHEGC1				

MOTORES / ENGINES / MOTORI  
6 & 4B Series 250 HP

**NEW**



Ref.	R.O. OEM	IMPULSOR IMPELLER GIRANTE
DJC2701	3922589	REC17000K

MOTORES / ENGINES / MOTORI  
QSB5.9  
QSB6.9  
Se suministra sin conexiones ni piñón delantero.  
It is supplied without connections or front pinion.  
Viene fornito senza connessioni o pignone  
anteriore.

**NEW**



**CUMMINS**

Ref.	R.O. OEM	ENTRADA INLET ENTRATA	SALIDA OUTLET USCITA	IMPULSOR IMPELLER GIRANTE
SHEP1716C	3922590 3919899	Ø 2"	Ø 1 3/4"	REC17000K

**MOTORES / ENGINES / MOTORI**  
6B Series



Ref.	R.O. OEM	IMPULSOR IMPELLER GIRANTE
SHEP1016	854179001 879312023	SHE10615K

**MOTORES / ENGINES / MOTORI**  
CMD 2.8 EI, ES (170/200)  
CMD QSD 2.8 EI, ES (170/210/220/230)  
CMD QSD 2.0 EI, ES (115/130/150)

**NEW**



Ref.	R.O. OEM	ENTRADA INLET ENTRATA	SALIDA OUTLET USCITA	IMPULSOR IMPELLER GIRANTE
SHEGC5	39127684	Ø 1 1/2"	Ø 1 1/2"	REC15000K

**MOTORES / ENGINES / MOTORI**  
6B Series 250 HP



Ref.	R.O. OEM	IMPULSOR IMPELLER GIRANTE
SHEG2603X	3967246 3922589	SHE26000K

**MOTORES / ENGINES / MOTORI**  
QSC & QSM11  
QSC & QSB

Codos no incluidos  
Elbows not included  
Gomito non incluso

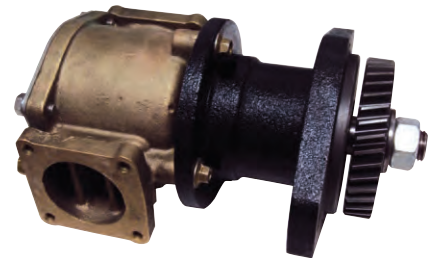

Ref.	R.O. OEM	IMPULSOR IMPELLER GIRANTE
SHEP2708X		SHE27000K

**MOTORES / ENGINES / MOTORI**  
QSC

Codos no incluidos  
Elbows not included  
Gomiti non incluso



Ref.	R.O. OEM	IMPULSOR IMPELLER GIRANTE
SHEG2903X	4929178 3349392 5260393	SHE29000K

**MOTORES / ENGINES / MOTORI**  
QSM11

Codos no incluidos  
Elbows not included  
Gomito non incluso



Ref.	R.O. OEM	IMPULSOR IMPELLER GIRANTE
SHEP1727C	3897194	REC17000K

**MOTORES / ENGINES / MOTORI**  
6B & 6C 270-450 HP  
8.3L

Codos con brida  
Flanged Elbows  
Gomiti con fascetta



REF	IMPULSOR IMPELLER GIRANTE	KIT MENOR KIT MINOR KIT MINORE	KIT MAYOR KIT MAJOR KIT MAGGIORE
DJC004	CEF500135		
DJC0819	REC17000K		
DJC0820	REC10615K		
DJC0830	REC15000K		
DJC1730	REC17000K		
DJC2701	REC17000K		
SHEGC1	SHE15000K	SHE23980	SHE23981
SHEGC5	SHE15000K	SHE23980	SHE23981
SHEG2603X	SHE26000K	SHE24841	SHE24842
SHEG2903X	SHE29000K	SHE25044	SHE25045
SHEM71	SHE10615K	SHE23976	SHE23977
SHEP1016	SHE10615K		
SHEP1716C	SHE17000K	SHE25124	SHE25122
SHEP1722C	SHE17000K	SHE25124	SHE25122
SHEP1727C	SHE17000K	SHE25124	SHE25122
SHEP1730C	SHE17000K	SHE25124	SHE25122
SHEP2708X	SHE27000K	SHE25125	SHE25126

# IMPULSORES IMPELLER GIRANTE

R.O. OEM	PALAS BLADES PALE	SHERWOOD	CEF	RECMAR	MEDIDAS (mm) MEASURES (mm) MISURE (mm)		
					A	B	C
3802444 3897337 3916852 3925236	12	SHE17000K	CEF500164T	REC17000K	20,1	84	73,5
3349198 3916720	12	SHE15000K	CEF500167	REC15000K	16	65	51,2
3908220	12	SHE10615K	CEF500120T	REC10615K	15,9	65,2	41,3
3972366	12	SHE26000K	CEF500183G		20	94,5	79,8
3974456	12	SHE27000K	CEF500181G	REC27000K	16,1	84	73
	12	SHE29000K	CEF500192GX	REC29000K	20	94,5	101,5
4019403 4933743	12	SHE18000K	CEF500182G	REC18000K	20,7	94,5	101,5

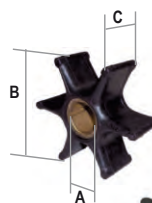

REC10615K



REC27000K



REC29000K

## MOTORES DE ARRANQUE STARTERS MOTORINO D'AVVIAMENTO

Ref.	R.O. OEM	DIENTES TOOTH DENTI
PH150-0008	3916854 3904445	12V 10

### MOTORES / ENGINES / MOTORI

3.9L 4 cil & 5.9L 6 cil  
6BT & Peninsular 6.2L  
6.9 & 7.3L Star Power



## ALTERNADORES ALTERNATOR ALTERNATORE

Ref.	R.O. OEM	POLEA SERPENTIN GROOVE PULLEY PULEGGIA A SERPENTINA
PH300-0012	12V 65A	6 (50 mm)

### MOTORES / ENGINES / MOTORI

EI 165, 250, 300  
ES 165, 250, 300  
2.8 & 4.2L



Ref.	R.O. OEM	DIENTES TOOTH DENTI
REC3604654RX	3604654RX	12V 10

### MOTORES / ENGINES / MOTORI

6BT 5.9L

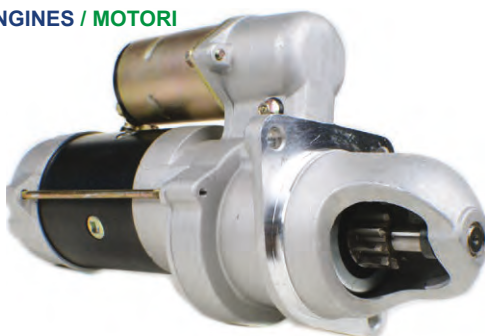

Ref.	R.O. OEM	POLEA SERPENTIN GROOVE PULLEY PULEGGIA A SERPENTINA
REC882571	882571 8M0084523	12V 50A 6 (50 mm)

### MOTORES / ENGINES / MOTORI

CMD 1.7 MI 120 L/L4  
CMD 1.7 MS 120 L/L4

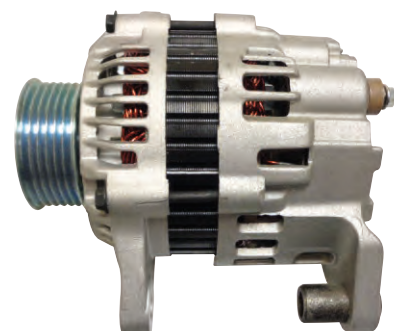



CUMMINS

SILENTBLOCK

Ref.	KG (LBS)	TORNILLO STUD PERNO	DISTANCIA ENTRE AGUJEROS MOUNT HOLE CENTERS DISTANZA TRA I FORI
RECDF477-M-3	430 - 900 (950 - 2000)	3/4"	127 mm

MOTORES / ENGINES / MOTORI  
3.9L 4 cil.  
5.9L 6 cil.  
80 - 370 hp



ÁNODOS DE ZINC  
ZINC ANODES  
ANODI IN ZINCO



SOLO ÁNODO  
ONLY ANODE  
SOLO ANODO



REF	R.O. OEM	kg / lbs	Ø mm	L mm	L1 mm	b
TEN02040		0,140 / 0.309	18	65	15	16 x 1,5 mm
TEN02041		0,045 / 0.099	16	31	12	3/8" UNC
TEN02042		0,012 / 0.026	10	20	8	M6
TEN02043		0,085 / 0.187	16	50	10	15,5 mm
TEN02044	68241	0,070 / 0.154	15,5	50	9	7/16"



TAPÓN DE BRONCE  
BRASS PLUG  
TAPPO IN OTTONE

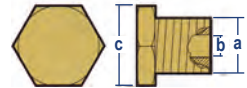

REF	R.O. OEM	kg / lbs	a	b	c mm
TEN02044TP		0,055 / 0.121	1/2" gas conico (bspt)	7/16" UNF	22

COMPLETO  
COMPLETE  
COMPLETO



REF	kg / lbs	Ø mm	L mm	a	c mm
TEN02043T	0,120 / 0.265	16	50	1/2" gas conico	22
TEN02044T	0,120 / 0.265	15,5	50	1/2" gas conico	22



DETROIT DIESEL

CODO DE ESCAPE  
EXHAUST ELBOW  
GOMITO SCARICO

Ref.	R.O. OEM
HGE1086	

MOTORES / ENGINES / MOTORI  
DD 6-71TI



# BOMBA DE AGUA MARINA RAW MARINE WATER PUMP POMPE ACQUA MARINA

Ref.	R.O. OEM	IMPULSOR IMPELLER GIRANTE
REC5197221	5197221	REC17937-0001

MOTORES / ENGINES / MOTORI  
271



Ref.	R.O. OEM	JABSCO	IMPULSOR IMPELLER GIRANTE
REC5145578	5145578	17050	REC17937-0001
	5145577	7260	
	5145576	17030	

MOTORES / ENGINES / MOTORI  
353  
453  
471



Ref.	R.O. OEM	JABSCO	IMPULSOR IMPELLER GIRANTE
REC8923363	8923363	18760	REC17937-0001
	23507475		
	23507476		
	23507477		
	23507973		

MOTORES / ENGINES / MOTORI  
8V92TA  
16V92TA



Ref.	R.O. OEM	IMPULSOR IMPELLER GIRANTE
DJG0816	23507971	CEF500135
	5186250	
	5107480	
	23501083	
	5115396	

MOTORES / ENGINES / MOTORI  
6V53  
6V71  
8V53



Ref.	R.O. OEM	JABSCO	IMPULSOR IMPELLER GIRANTE
REC8927296	8927296	18780	REC18786-0001
	18780	18789	

MOTORES / ENGINES / MOTORI  
12V71TI  
12V92TA  
16V149TA



Ref.	R.O. OEM	JABSCO	IMPULSOR IMPELLER GIRANTE
REC23535447	23535477	17540-0001	REC18786-0001
	23525200	17540-0201	

MOTORES / ENGINES / MOTORI  
60



Ref.	R.O. OEM	IMPULSOR IMPELLER GIRANTE
DJG0815	23507972	CEF500145T
	5122599	
	5106016	
	8924265	
	23501769	

MOTORES / ENGINES / MOTORI  
6V71TI  
8V71  
12V71



## ÁNODOS DE ZINC ZINC ANODES ANODI IN ZINCO

REF	R.O. OEM	ROSCA TAPÓN PLUG THREAD PASSO TAPPO	Ø mm	LONGITUD LENGTH LUNGHEZZA	ROSCA THREAD PASSO
CME4		3/4"	19	86	5/8 x 11
CME2		1/2"	16	51	7/16 x 14
CM8515842		3/4"	19	58	5/8 x 11
CM8515850		3/4"	19	100	5/8 x 11
CME1E		3/8"	12.7	38	3/8 x 16



**DETROIT DIESEL**

**IMPULSORES  
IMPELLER  
GIRANTE**

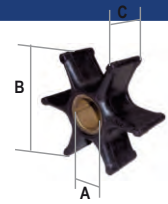

R.O. OEM	PALAS BLADES PALE	JOHNSON	JABSCO	SHERWOOD	CEF	RECMAR	MEDIDAS (mm) MEASURES (mm) MISURE (mm)		
							A	B	C
	10			SHE18000K	CEF500114T	REC17937-0001	14,29	65	50,1
8927570	12		JAB17370-0001		CEF500152	REC17370-0001	20,2	95	88,5
23502086	9		JAB18786-0001		CEF500153	REC18786-0001	20,2	117,6	88,5
5196168	12	JOH09-814B			CEF500145T	REC875697	22,5	95	88,5
8924838	12	JOH09-819B			CEF500135		22,5	95	63,1
5193553	9	JOH09-1029B			CEF500105T	REC836-0001	22,5	96	93,1
5193602	8	JOH09-1028B			CEF500106GT	REC3841697	14,29	65	50,2
5196629									
5199148									



**HURT**

**COMPONENTES  
PARTS  
COMPONENTI**

**KITS REPARACIÓN TRANSMISIÓN  
TRANSMISSION REPAIR KIT  
KIT RIPARAZIONE TRASMISSIONE**

Ref.	R.O. OEM
A/P2280	

**MOTORES / ENGINES / MOTORI**  
10 & 150

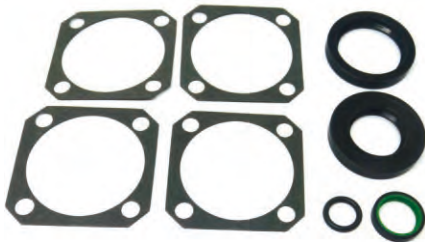

Ref.	R.O. OEM
A/P2281	

**MOTORES / ENGINES / MOTORI**  
20, 220 & 250

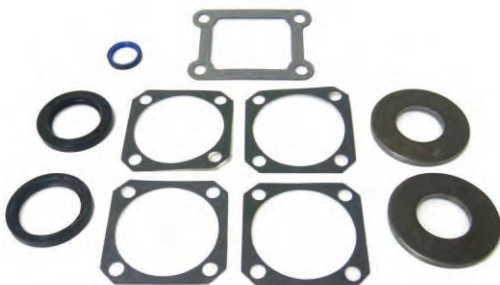

Ref.	R.O. OEM
A/P2293	

**MOTORES / ENGINES / MOTORI**  
5, 50 & 100

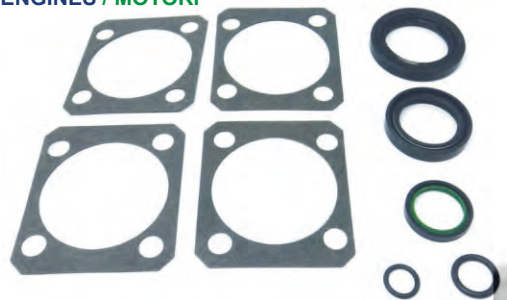

**FILTRO TRANSMISIÓN  
TRANSMISSION FILTER  
FILTRO TRASMISSIONE**

Ref.	R.O. OEM
REC016940	35-815419
	8791014241
	879194241
	35-813405A1
	35-813405
	F19608751 FFF001138



**COLECTORES, CODOS, Y JUNTAS**  
**MANIFOLDS, ELBOWS & GASKETS**  
**COLLETTORI, GOMITI, E GUANIZIONI**

**COLECTOR**  
**MANIFOLD**  
**COLLETTORI**

Ref.	R.O. OEM	KIT TORNILLERÍA HARDWARE KIT BULLONERIA	R.O. OEM
HOT20997	0994-000	OSC994-MK	

**MOTORES / ENGINES / MOTORI**

V8 5.0 & 5.7L  
 Bloque pequeño / Small block / Blocco piccolo  
 305 & 350

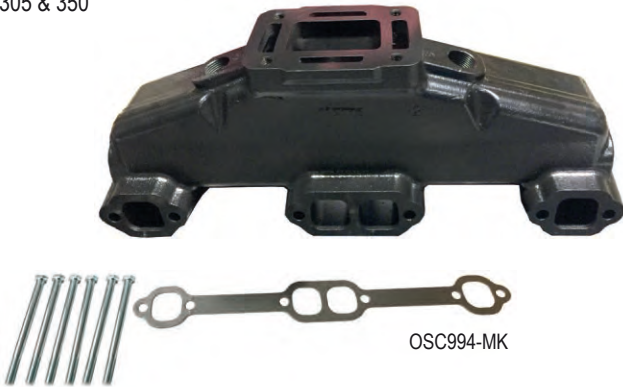

OSC994-MK

Ref.	R.O. OEM	KIT TORNILLERÍA HARDWARE KIT BULLONERIA	R.O. OEM
HOT20998	53-2800	HOT20998-MK	

**MOTORES / ENGINES / MOTORI**

302-351

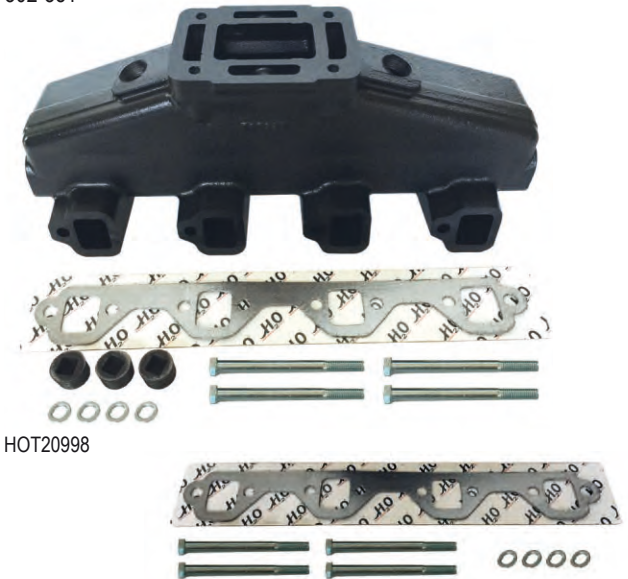

HOT20998

HOT20998-MK

**CODO**  
**ELBOW**  
**GOMITO**

Ref.	R.O. OEM		
HGE2018	53-2009	30°	3"
HOT20907	53-2018		
HGE2027	53-2027-T	30°	3,5"
HOT20939		10°	4"

**MOTORES / ENGINES / MOTORI**

V8 5.0 & 5.7L  
 Bloque pequeño / Small block / Blocco piccolo  
 305 & 350



HGE2018

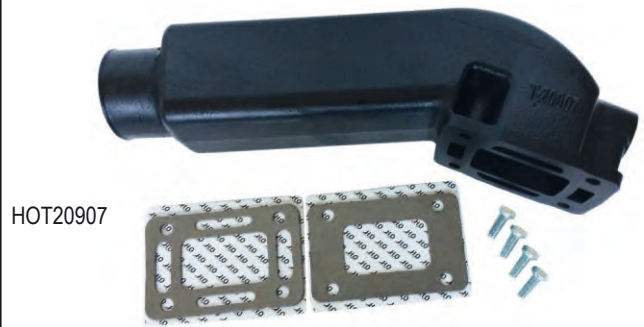

HOT20907

**NEW**



HGE2027

**NEW**



HOT20939

**KITS MONTAJE CODO**  
**ELBOW KIT**  
**KIT MONTAGGIO GOMITO**

Ref.	R.O. OEM
OSC992-MK	

**MOTORES / ENGINES / MOTORI**

V8  
 Bloque pequeño / Small block / Blocco piccolo



**NEW**

**BOMBA DE AGUA  
WATER PUMP  
POMPA ACQUA**

**BOMBA  
PUMP  
POMPA**

Ref.	R.O. OEM	KIT REPARACIÓN REPAIR KIT KIT RIPARAZIONE
REC3860703	685011	REC21213660



**IMPULSOR  
IMPELLER  
GIRANTE**

Ref.	R.O. OEM
JOH09-802B	



**TUBO COMBUSTIBLE DE BOMBA A CARBURADOR  
FUEL TUBE FROM PUMP TO CARBURETOR  
TUBO CARBURANTE DA POMPA A CARBURATORE**

Ref.	
REC18-8114	3/8" X 31" PTFE - 5/8"
REC18-8115	3/8" X 25" PTFE - 5/8"



**ENCENDIDO  
IGNITION  
ACCENSIONE**

**PLATINO  
POINT  
PUNTINE**

Ref.	R.O. OEM
REC8M6001219	751007



**ROTORES  
ROTORS  
ROTORI**

Ref.	R.O. OEM
REC834975	



**CONDENSADORES  
CONDENSERS  
CONDENSATORE**

Ref.	R.O. OEM
REC33662	755017



**BOBINA  
IGNITION COIL  
BOBINE**

Ref.	R.O. OEM
REC1463-9382	



Resistencia externa.  
Utilizar con encendido convencional.  
External resistor. Use with conventional  
ignition

Resistenza esterna. Utilizzare con accensione  
convenzionale

JUEGOS DE CABLE PARA BUJÍAS DE ALTO RENDIMIENTO  
 HD SPARK PLUG WIRE SET  
 KIT CAVI CANDELE ALTE PRESTAZIONI

Ref	MODELO MODEL MOELLO	ARRANQUE CONVENCIONAL IGNITION CONVENTIONAL AVVIAMENTO CONVENZIONALE	ARRANQUE ELECTRÓNICO IGNITION ELECTRONIC AVVIAMENTO ELETTRONICO	CYL
REC15-401	181 3.0L	✓		4
REC15-405	181 3.0L		✓	4
REC15-602	250 (In-line 6)	✓		6
REC15-604	262 4.3L	✓		6
REC15-601	262 4.3L		✓	6
REC15-801	302, 351 5.0L-5.8L (Ford)	✓		8
REC15-801	350 5.7L	✓		8
MAG15-803	350 5.7L		✓	8
REC15-801	454 7.4L, 502 6.2L	✓		8
MAG15-803	454 7.4L, 502 6.2L		✓	8
MAG15-809	454, 502 (Straight plug boot)		✓	8
REC15-806	V8 Mallory Side Term. Cap	✓		8



MOTORES DE ARRANQUE  
 STARTERS  
 MOTORINO D'AVVIAMENTO

Ref.	R.O. OEM		DIENTES TOOTH DENTI
PH140-0022	573001	12V 1.4kw	9

MOTORES / ENGINES / MOTORI  
 GM & Ford



Ref.	R.O. OEM		DIENTES TOOTH DENTI
PH140-0022-CCW		12V 1.4kw	9

Contrarrotación o montaje en campana  
 CCW Starter  
 Controrotante o montato nella campana



ALTERNADORES  
 ALTERNATORS  
 ALTERNATORI

Ref.	R.O. OEM		
PH300-0041	575011	12V 70A	

Polea serpentina  
 Serpentine pulley  
 Pulleggia serpentina



Ref.	R.O. OEM		
PH300-0032	575010	12V 70A	

Polea correa  
 V-belt pulley  
 Pulleggia cinghia



**COMPONENTES  
PARTS  
COMPONENTI**

**FILTRO COMBUSTIBLE  
FUEL FILTER  
FILTRO COMBUSTIBILE**

Ref.	R.O. OEM
REC252898	252898

**MOTORES / ENGINES / MOTORI**  
11, 11.5, 13, 13.5, 14, 15, 15.5, 16,  
17.5, 18.5, 19, 20, 23, 24 (CCFOZ,  
EFOZ, E0ZD)



**KIT TERMOSTATO  
THERMOSTAT KIT  
KIT TERMOSTATO**

Ref.	R.O. OEM
REC23-3665	

**MOTORES / ENGINES / MOTORI**  
1.6: 11CCFOZ, 11,5CCFOZ, 11EFOZ,  
11,5EFOZ, 13EOZ, 13EFOZ, 13,5CCOZ,  
14CCOZ, 14EOZ, 15,5EOZ.

16EFOZ, 17,5EFOZ, 18,5CCOZ, 19EFOZ,  
20CCFOZ, 20EOZ, 20EFOZ, 23EOZ,  
24CCOZ, 24EOZ



**FILTRO ACEITE  
OIL FILTER  
FILTRO OLIO**

Ref.	R.O. OEM
REC502900	279449

**MOTORES / ENGINES / MOTORI**  
12.5CF, 15C, 16CF, 20C.



Ref.	R.O. OEM
REC23-3666	

**MOTORES / ENGINES / MOTORI**

**Variación 1:**  
33EFOZ, 33CFOZ, 40CFOZ, 40EOZ, 40EFOZ,  
50COZ, 50CFOZ, 50EOZ, 55EFOZ, 65 COZ,  
65EOZ, 70EFOZ, 80EOZ. 80EFOZ, 99EOZ,  
100EFOZ, 125EOZ, 125EFOZ, 150EOZ



Ref.	R.O. OEM
REC834337	359771

**MOTORES / ENGINES / MOTORI**  
4EF, 5E, 6EF, 7.3E.



Ref.	R.O. OEM
REC229678	229678

**MOTORES / ENGINES / MOTORI**  
4CCFOZ, 4EFOZ, 5CCOZ, 5EOZ,  
6.5EFOZ, 8EOZ.



**ÁNODOS DE ZINC  
ZINC ANODES  
ANODI IN ZINCO**

Ref.	R.O. OEM
CME0	260085 267928



# BOMBA DE AGUA WATER PUMP POMPA ACQUA

Ref.	R.O. OEM	Ø ENTRADA Ø INLET Ø ENTRATA	Ø SALIDA Ø OUTLET Ø USCITA	IMPULSOR IMPELLER GIRANTE
REC29350-1001	GM58527			CEF500100GX

MOTORES / ENGINES / MOTORI  
6EOD 4.5EFOD



Ref.	R.O. OEM	Ø ENTRADA Ø INLET Ø ENTRATA	Ø SALIDA Ø OUTLET Ø USCITA	IMPULSOR IMPELLER GIRANTE
SHEG907P	344085 344371	3/8"	3/8"	REC09000K

MOTORES / ENGINES / MOTORI

Ford  
4T o 6.5 kw



Ref.	R.O. OEM	Ø ENTRADA Ø INLET Ø ENTRATA	Ø SALIDA Ø OUTLET Ø USCITA	IMPULSOR IMPELLER GIRANTE
SHEG8001	132-0275	3/8"	3/8"	REC08000K

MOTORES / ENGINES / MOTORI  
5-7 KW Diesel Generator



Ref.	R.O. OEM	Ø ENTRADA Ø INLET Ø ENTRATA	Ø SALIDA Ø OUTLET Ø USCITA	IMPULSOR IMPELLER GIRANTE
SHEG910P	GM46936	3/8" NPT	3/8" NPT	REC09000K

MOTORES / ENGINES / MOTORI

Ford



Ref.	R.O. OEM	Ø ENTRADA Ø INLET Ø ENTRATA	Ø SALIDA Ø OUTLET Ø USCITA	IMPULSOR IMPELLER GIRANTE
SHEG906	267373 246489 344089	3/8"	3/8"	REC09000K

MOTORES / ENGINES / MOTORI  
4 & 6 Cyl Diesel  
12.5 Kw Gas



## IMPULSORES IMPELLER GIRANTE

R.O. OEM	PALAS BLADES PALE	SHERWOOD	CEF	RECMAR	MEDIDAS (mm) MEASURES (mm) MISURE (mm)		
					A	B	C
229826	12	SHE09000K	CEF500165	REC09000K	15,9	62,2	22,4
229955 250872	6		CEF500129	REC22779-0001	12,75	50,8	22,1
359978	6	SHE08000K	CEF500190G	REC08000K	12,2	19	40
	12	SHE10077K	CEF500166	REC10077K	12,7	57	19,8
	12	SHE09959K	CEF500103T	REC3854286	16	62	31,5
	12	SHE10615K		REC10615K	15,9	65	41,2

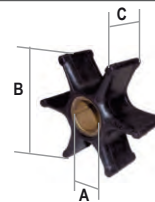

REC09000K



REC22779-0001



REC08000K



REC10077K



REC3854286



REC10615K



**IMPULSORES  
IMPELLER  
GIRANTE**

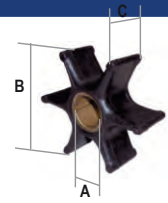

R.O. OEM	MOTORES ENGINES MOTORI	PALAS BLADES PALE	JOHNSON	CEF	RECMAR	MEDIDAS (mm) MEASURES (mm) MISURE (mm)		
						A	B	C
51.06506.0127	D2862LR443	12	JOH09-842B					
51.06506.0103	D2866	12	JOH09-821B	CEF500162G		22,5	65,8	80
50.06506.0089		12	JOH09-814B	CEF500145T	<b>REC875697</b>	22,5	95	88,5
50.06506.0091	D2866	8	JOH09-1028B	CEF500106GT	<b>REC3841697</b>	14,29	65	50,2
51.06506.0106	1050 1100	12	JOH09-820B	CEF500186T		22,5	96,5	130
	1200 1300							
	1360 1550 HP							



**NANNI DIESEL**

**IMPULSORES  
IMPELLER  
GIRANTE**

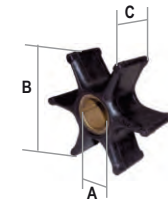

R.O. OEM	MOTORES ENGINES MOTORI	PALAS BLADES PALE	JOHNSON	JABSCO	CEF	RECMAR	MEDIDAS (mm) MEASURES (mm) MISURE (mm)		
							A	B	C
434014		6	JOH09-810B		CEF500101X	<b>REC653-0001</b>	12,17	50,8	22,1
434013	FK2,40E/HE L30 2.60H 3.90 KLA	6	JOH09-808B		CEF500121GX	<b>REC3586496</b>	12	39,6	19,2
	FK3 3.75HE 2.45H2 3.90H/HE 2.5HE 4.110.H 2.60HE	10			CEF500146X		12,17	51,8	22
	3.100HE 4.190HE 3.110HE 4.200HE 4.110HE MB180 4.150HE 220 4.180 230	12	JOH09-1027B			<b>REC21213660</b>	14,29	57	31,6
	4.220HE 5.300/T 4.330TDI 6.280HE 4.440E 6.570T 5.280HE 6.660E/LE 5.250TDI	10		JAB17937-0001-P	CEF500114T	<b>REC17937-0001</b>	14,29	65	50,1
	4.230 4.380 4.240 5.300	8	JOH09-1028B		CEF500106GT	<b>REC3841697</b>	14,29	65	50,2
	1300,16	12	JOH09-814B		CEF500135	<b>REC21730344</b>	22,5	95	63,1



**ALTERNADORES  
ALTERNATOR  
ALTERNATORE**

Ref.	R.O. OEM	POLEA PULLEY PULEGGIA
PH300-0027-OE	48200932	12V 60A RM841812

**MOTORES / ENGINES / MOTORI**

NK2.4ECO	NK4.200HE
NK2.50HE	NK4.220HE
NK3.100HE	NK5.250TDI
NK3.75HE	NK5.2800HE
NK4.150HE	



Se suministra sin polea.  
It is supplied without pulley.  
Viene fornito senza puleggia.



# COMPONENTES PARTS COMPONENTI

## FILTRO COMBUSTIBLE FUEL FILTER FILTRO COMBUSTIBILE

Ref.	R.O. OEM
REC122B326	122B326

### MOTORES / ENGINES / MOTORI

7,5MAJE-120MDJC-J30-J60  
MAJ2,5-MDJE6,0-MDJF12  
MDJF150-J120JA-J120JB-JC  
MJA-MJB-MJC-RJC-GMDJB/37  
DJ30-15MDJ/3R-MDJ/30-DJ/60  
DJ/120-DJ/130-MDJ/130  
705MDJE/3R-DJA-DJB-DJC-MDJA-B



Ref.	R.O. OEM
REC149-0428	149-0428

### MOTORES / ENGINES / MOTORI

MDJA, MDJB, MDJC (Spec A-R)  
MDJE, MDJC (Spec. A)



Ref.	R.O. OEM
REC1492250I	1492250

### MOTORES / ENGINES / MOTORI

40DGCA-50DGCA  
30MDGBA-35MDGCA  
45MDGCA

BY-PASS I  
Filtro / Filter / Filtro I



Ref.	R.O. OEM
REC1492251II	1492251 II

### MOTORES / ENGINES / MOTORI

40DGCA-50DGCA  
30MDGBA-35MDGCA  
45MDGCA

BY-PASS II  
Filtro / Filter / Filtro II



Ref.	R.O. OEM
REC1491758	1491758

### MOTORES / ENGINES / MOTORI

20KW-MDL4W2423D  
MDLGLWG34D-L423D-L423  
L423P-LG34W-25MDLG  
45MDLG-30MDLG-L317DW  
16MDL224-20MDL4-12MDL3



Ref.	R.O. OEM
REC149-2106	149-2106

### MOTORES / ENGINES / MOTORI

8,0DKD  
10DKG



Ref.	R.O. OEM
REC1491754	1491754

### MOTORES / ENGINES / MOTORI

50DDB-W9D

Filtro cristal  
Crystal filter  
Filtro in vetro



## FILTRO ACEITE OIL FILTER FILTRO OLIO

Ref.	R.O. OEM
REC1220185	1220185 122-0185

### MOTORES / ENGINES / MOTORI

7,5MAJE-120MDJC-J30-J60-MAJ2,5  
MDJE6,0-MDJF12-MDJF150-J120JA  
J120JB-JC-MJA-MJB-MJC-RJC  
GMDJB/37-DJ30-15MDJ/3R-MDJ/30  
DJ/60-DJ/120-DJ/130-MDJ/130  
705MDJE/3R-DJA-DJB-DJC-MDJA-B  
MDJB, MDJC, MDJE, MDJF, MJA, MJB, MJC



**ONAN**

Ref.	R.O. OEM
REC1220602	1220602

**MOTORES / ENGINES / MOTORI**  
L317DW-16MD224-20MDL4-12MDL3  
Filtro Corto / Small filter / Filtro corto



Ref.	R.O. OEM
REC185-2133	185-2133

**MOTORES / ENGINES / MOTORI**  
8.0DKD-10DKG



Ref.	R.O. OEM
REC35-06003	

**MOTORES / ENGINES / MOTORI**  
50DDB-W9D



Ref.	R.O. OEM
REC1220810	1220810 122-0810

**MOTORES / ENGINES / MOTORI**  
17,5 MDKAE  
MDKDB  
MDKBF  
MDKAD  
MDKAE  
MDKAF



Ref.	R.O. OEM
REC1870014	187.0014

**MOTORES / ENGINES / MOTORI**  
45MDGGA  
55MDGGA



Ref.	R.O. OEM
REC1855835	1855835 185-5835

**MOTORES / ENGINES / MOTORI**  
8,5KV-10KV  
MDKAA  
MDKAB  
MDKAV  
MDKBG  
MDKAW  
MDKAZ  
MDKAL  
MDKBK  
MDKBL  
MDKBM  
MDKBN



Ref.	R.O. OEM
REC1220716712	122.0716.712

**MOTORES / ENGINES / MOTORI**  
40DGCA-50DGCA  
30MDGGA-35MDGGA  
45MDGGA



Ref.	R.O. OEM
REC1220550	122-0550

**MOTORES / ENGINES / MOTORI**  
20KW-MDL4W2423D-MDLGWLG34D  
L423D-L423-L423P-LG34W-25MDLG  
45MDLG-30MDLG-L317DW-16MDL224  
20MDL4-12MDL3



**BOMBA DE AGUA MARINA  
RAW MARINE WATER PUMP  
POMPE ACQUA MARINA**

Ref.	R.O. OEM	IMPULSOR IMPELLER GIRANTE
SHEG702	132-0358 132-0459	REC10077K

**MOTORES / ENGINES / MOTORI**  
6.5 - 10Kw



# BOMBA DE AGUA WATER PUMP POMPA ACQUA

Ref.	R.O. OEM	Ø ENTRADA Ø INLET Ø ENTRATA	Ø SALIDA Ø OUTLET Ø USCITA	IMPULSOR IMPELLER GIRANTE
SHEK75B	132-0275 135-0278	1"	1"	REC3854286

**MOTORES / ENGINES / MOTORI**  
4 CYL



Ref.	R.O. OEM	Ø ENTRADA Ø INLET Ø ENTRATA	Ø SALIDA Ø OUTLET Ø USCITA	IMPULSOR IMPELLER GIRANTE
SHEL10B	1320278 132-0278	1 1/4"	1 1/4"	REC10615K

**MOTORES / ENGINES / MOTORI**  
5 CYL  
MDL6 (30Kw)



Ref.	R.O. OEM	Ø ENTRADA Ø INLET Ø ENTRATA	Ø SALIDA Ø OUTLET Ø USCITA	IMPULSOR IMPELLER GIRANTE
SHEG1010	132-0343	1"	1"	REC10615K
	132-0347			
	132-0356			
	132-0413			

**MOTORES / ENGINES / MOTORI**  
10-25 Kw  
Reemplaza / Replace / Sostituisce: G1004, G1005, G1008



Ref.	R.O. OEM	Ø ENTRADA Ø INLET Ø ENTRATA	Ø SALIDA Ø OUTLET Ø USCITA	IMPULSOR IMPELLER GIRANTE
SHEG8002	132-0395 132-0430			REC08000K

**MOTORES / ENGINES / MOTORI**  
Reemplaza / Replace / Sostituisce: G1009



Ref.	R.O. OEM	Ø ENTRADA Ø INLET Ø ENTRATA	Ø SALIDA Ø OUTLET Ø USCITA	IMPULSOR IMPELLER GIRANTE
SHEG1012	132-0464	1 1/4"	1 1/4"	REC10615K

**MOTORES / ENGINES / MOTORI**  
Reemplaza / Replace / Sostituisce: G1009



MODELO MODEL MODELLO	Nº MOTOR ENGINE NUMBER N. MOTORE	IMPULSOR IMPELLER GIRANTE	KIT MENOR KIT MINOR KIT MINORE	KIT MAYOR KIT MAJOR KIT MAGGIORE
12MDJC-15 MDJF	132C115	SHE09959K		
4CYL DIESEL	132-0275	SHE09959K	SHE23979	SHE12665
5CYL DIESEL	132-0278	SHE10615K	SHE23976	SHE23977
5CYL DIESEL	132-0271	SHE09000K		
5CYL DIESEL	132-0343	SHE10615K		
5CYL DIESEL	132-0347	SHE10615K		
10-25Kw	132-0356	SHE10615K		SHE22276
6.5-10Kw	132-0358	SHE10077K		
4.8Kw		SHE08000K		

**IMPULSORES  
IMPELLER  
GIRANTE**

R.O. OEM	PALAS BLADES PALE	JOHNSON	SHERWOOD	CEF	RECMAR	MEDIDAS (mm) MEASURES (mm) MISURE (mm)		
						A	B	C
08-21-1201 132-0162 131-0050	12	JOH09-1027B		CEF500107T	<b>REC21213660</b>	14,29	57	31,6
132-0117 132-0317	12		SHE09959K	CEF500103T	<b>REC3854286</b>	15,9	62	31,7
132-0349 132-0348 132-0292	12		SHE10615K	CEF500120T	<b>REC10615K</b>	15,9	65,2	41,3
132-0375	12		SHE10077K	CEF500166	<b>REC10077K</b>	12,8	56,6	19,8
132-0859	6	JOH09-806B		CEF500100GX	<b>REC3586494</b>	9,54	39,6	18,94
132-0415	6		SHE08000K	CEF500190G	<b>REC08000K</b>	12,2	19	40

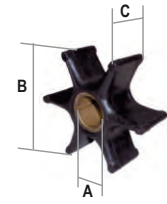

REC21213660



REC3854286

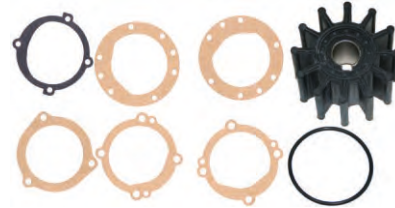

REC10615K



REC10077K



REC3586494



REC08000K

**ÁNODOS DE ZINC  
ZINC ANODES  
ANODI IN ZINCO**

REF	R.O. OEM	ROSCA TAPÓN PLUG THREAD PASSO TAPPO	Ø mm	LONGITUD LENGTH LUNGHEZZA	ROSCA THREAD PASSO
TEN02030			10	30	8
TEN02031		TEN02031TP	13	26	9,5
TEN02032			10	31	M8
TEN02033			12	40	3/8 UNC



COMPONENTES  
PARTS  
COMPONENTI

COLECTOR  
MANIFOLD  
COLLETTORE

Ref.	R.O. OEM
BAPE-1-6354	89058

MOTORES / ENGINES / MOTORI  
T6.354M - 160 HP



CODO  
ELBOW  
GOMITO

Ref.	R.O. OEM
SED3092201	

MOTORES / ENGINES / MOTORI  
T6.354.4AM  
220 HP



Ref.	R.O. OEM
SED3092200	

MOTORES / ENGINES / MOTORI  
T6.354.4AM  
220 HP



Ref.	R.O. OEM
MAR345	3776F024

MOTORES / ENGINES / MOTORI  
Perkins Prima Marine 50



Ref.	R.O. OEM	JUNTA GASKET GUARNIZIONE
MAR906 RM861906	135616660	REC861907

MOTORES / ENGINES / MOTORI

M20  
M30  
M35



FILTRO COMBUSTIBLE  
FUEL FILTER  
FILTRO COMBUSTIBILE

Ref.	R.O. OEM
REC3581078	2656017

MOTORES / ENGINES / MOTORI

4.154M 6.354 V8-605  
4.192 6.354M AV8-640  
4A.203 H6.354 TV8-640  
P4.192 H6354M  
P4.192Y 6.354  
P4.203 T6.354M  
4.203 HT6.354  
4.236 HT6.354M  
4.236M 6.3544  
4A236 T6.3544  
4.248 ST6.3544  
4.300 6.372  
A4.300 V8-510  
6.247 AV-8-540

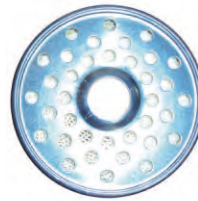

FILTRO ACEITE  
OIL FILTER  
FILTRO OLIO

Ref.	R.O. OEM
REC35-816168	2654407 2654347

MOTORES / ENGINES / MOTORI

4.154M 4.300 6.3544  
4.192 A4.300 T6.3544  
4A.203 6.247 ST6.3544  
P4.192 6.354 6.372  
P4.192Y 6.354M V8-510  
P4.203 H6.354 AV-8-540  
4.203 H6354M V8-605  
4.236 T6.354 AV8-640  
4.236M 6.354M TV8-640  
4A236 HT6.354  
4.248 HT6.354M



**BOMBA DE AGUA MARINA**  
**RAW MARINE WATER PUMP**  
**POMPE ACQUA MARINA**

Ref.	R.O. OEM	IMPULSOR IMPELLER GIRANTE
REC29350-1001	M20	CEF500100GX

MOTORES / ENGINES / MOTORI  
M20



670

**BOMBA DE AGUA**  
**WATER PUMP**  
**POMPA ACQUA**

Ref.	R.O. OEM	Ø ENTRADA Ø INLET Ø ENTRATA	Ø SALIDA Ø OUTLET Ø USCITA
SHERPBC	NA001175	1" NPT	1" NPT

MOTORES / ENGINES / MOTORI  
6-354



Ref.	R.O. OEM	Ø ENTRADA Ø INLET Ø ENTRATA	Ø SALIDA Ø OUTLET Ø USCITA
REC09140	NA001175	1 1/4" NPT	1 1/4" NPT

MOTORES / ENGINES / MOTORI  
4.107-4.154



Ref.	R.O. OEM	Ø ENTRADA Ø INLET Ø ENTRATA	Ø SALIDA Ø OUTLET Ø USCITA
SHEG65	NA003335	3/4" NPT	3/4" NPT



REF	IMPULSOR IMPELLER GIRANTE	KIT MENOR KIT MINOR KIT MINORE	KIT MAYOR KIT MAJOR KIT MAGGIORE
SHERPBC	SHE10615K	SHE10999	SHE11068
SHEG65	SHE09959K		SHE12221
SHEH5	SHE09959K		SHE12980
REC09140	REC21213660	JOH09-1027B	CEF500107T

Ref.	R.O. OEM	Ø ENTRADA Ø INLET Ø ENTRATA	Ø SALIDA Ø OUTLET Ø USCITA
SHEH5	NA005576	1"	1"

MOTORES / ENGINES / MOTORI  
4-154  
6-345D



# ÁNODOS DE ZINC ZINC ANODES ANODI IN ZINCO

REF	R.O. OEM	ROSCA TAPÓN PLUG THREAD PASSO TAPPO	Ø mm	LONGITUD LENGTH LUNGHEZZA	ROSCA THREAD PASSO
TEN02040		Sólo ánodo Only anode Solo anodo	18	65	16 x 1,5
TEN02041		Sólo ánodo Only anode Solo anodo	16	31	3/8 UNC
TEN02042		Sólo ánodo Only anode Solo anodo	10	20	M6
TEN02043T		1/2 BSPT	16	50	15,5 mm
TEN02044T		1/2 BSPT	16	50	7/16" UNF
TEN02000T		1/2 BSPT	16	54	7/16" UNF

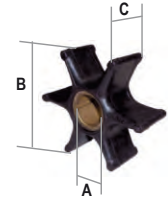

# IMPULSORES IMPELLER GIRANTE

R.O. OEM	PALAS BLADES PALE	JOHNSON	JABSCO	SHERWOOD	CEF	RECMAR	MEDIDAS (mm) MEASURES (mm) MISURE (mm)		
							A	B	C
24880272	6	JOH09-806B			CEF500100GX	REC3586494	9,54	39,6	18,94
24880194	6	JOH09-1026B			CEF500116GX	REC3593659	12,66	50,8	22,1
0460027	9	JOH09-1029B			CEF500105T	REC836-0001	22,5	96	63,1
24880190	12	JOH09-1027B			CEF500107T	REC21213660	14,29	57	31,6
24880031	10		JAB17937-0001-P		CEF500114T	REC17937-0001	14,29	65	50,1
0460024	12				CEF500145T	REC875697	22,5	95	88,5
460027	12				CEF500103T	REC3854286	15,9	62	31,7
NA900010	12			SHE09959K	CEF500120T	REC10615K	15,9	65,2	41,3
24880178	12			SHE10615K					
NA900012	12								



# MOTORES DE ARRANQUE STARTER MOTORINO DI AVVIAMENTO

Ref.	R.O. OEM	VOLTAJE / POWER	DIENTES TOOTH DENTI
REC21323043	185086600	12V 1.4 kw	9

**NEW**



Ref.	R.O. OEM	VOLTAJE / POWER	DIENTES TOOTH DENTI
REC21302969	185086610 185086620	12V 1.4 kw	9

**NEW**





**JUNTAS MOTOR  
ENGINE GASKET  
GUARNIZIONE MOTORI**

**JUNTAS CULATA  
CYLINDER HEAD GASKET  
GUARNIZIONI TESTATA**

Ref.	R.O. OEM
FEL17030	6269577



**MOTORES / ENGINES / MOTORI**  
GM 305, 350 CID

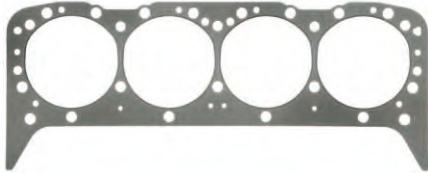

Ref.	R.O. OEM
FEL17060	RM0032



**MOTORES / ENGINES / MOTORI**  
Ford 302, 351 CID



**JUNTAS COLECTOR ESCAPE  
EXHAUST MANIFOL GASKET  
GUARNIZIONI COLLETTORE  
SCARICO**

Ref.	R.O. OEM
OSC7214-MK	



**MOTORES / ENGINES / MOTORI**  
Ford 305, 350 CID  
GM V8 (Bloque pequeño / Small  
block / Blocco piccolo)



Ref.	R.O. OEM
REC3852455	RM0007



Ref.	R.O. OEM
REC27-33395	CHV-47-000



**COLECTORES, CODOS, Y JUNTAS  
MANIFOLDS, ELBOWS & GASKETS  
COLLETTORI, GOMITI, E GUANIZIONI**

**COLECTOR  
MANIFOLD  
COLLETTORI**

Ref.	R.O. OEM	KIT TORNILLERÍA HARDWARE KIT BULLONERIA	R.O. OEM
HOT20996	R028001	HOT20996-MK	

**MOTORES / ENGINES / MOTORI**  
V8  
Bloque pequeño / Small block / Blocco piccolo

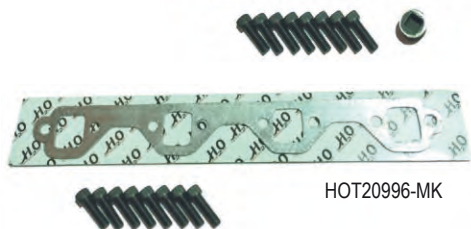
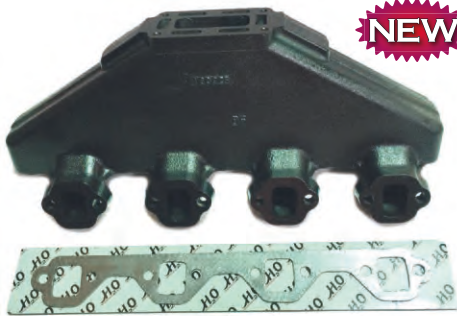

HOT20996-MK

**CODO  
ELBOW  
GOMITO**

Ref.	R.O. OEM	KIT TORNILLERÍA HARDWARE KIT BULLONERIA	R.O. OEM
HOT20899	R029001	HOT20899-MK	
HOT20011	R029011 3 1/2"		

**MOTORES / ENGINES / MOTORI**  
V8  
Bloque pequeño / Small block / Blocco piccolo

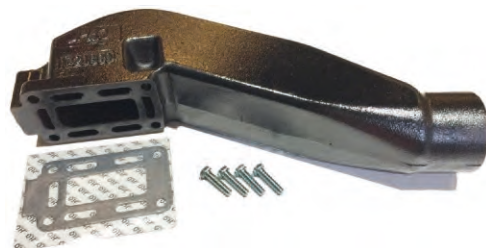

HOT20899

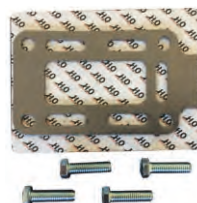

HOT20899-MK



HOT20011

**PROTECTOR SALIDA ESCAPE  
EXHAUST PROTECTOR VALVE  
PROTEZIONE SCARICO**

Ref.	
REC34765A2	3"
REC12644A1	4"
REC89260	5" 6"



REC12644A1



REC34765A2



REC89260

5" necesita 2 cortes de 45°  
5" requires two 45° cuts  
5" richiede due tagli a 45°

**NEW**

**TAPÓN DE DRENAJE  
DRAIN TAP  
TAPPO DI DRENAGGIO**

Ref.	
REC82745	1/4"



**NEW**

**BOMBA DE CIRCULACIÓN BLOQUE  
BLOCK CIRCULATING PUMP  
POMPA DI RICIRCOLO DI BLOCCO**

Ref.	R.O. OEM
PH600-0006	RA057004

**MOTORES / ENGINES / MOTO**  
Ford 302, 351W



**NEW**

Ref.	R.O. OEM
PH600-0002	RA057019

**MOTORES / ENGINES / MOTORI**  
GM V8 (bloque grande / big block /  
blocco grande)



**NEW**

Ref.	R.O. OEM
PH600-0005	RA057018

**MOTORES / ENGINES / MOTORI**  
GM V6 & V8 (bloque pequeño / small block /  
blocco piccolo)



**NEW**

**BOMBA ASPIRACIÓN AGUA MARINA  
RAW MARINE WATER PUMPS  
POMPE ASPIRAZIONE ACQUA MARINA**

Ref.	R.O. OEM	IMPULSOR IMPELLER GIRANTE
REC3860703	RA057026 RA057023	1 1/4" CEF500104

**MOTORES / ENGINES / MOTORI**  
5.7L



Ref.	R.O. OEM	IMPULSOR IMPELLER GIRANTE
SHEG21	RA57007	1" SHE09959K

**MOTORES / ENGINES / MOTORI**  
302 & 351



**PLEASURECRAFT**

Ref.	R.O. OEM		IMPULSOR IMPELLER GIRANTE
SHEP1014	40050	1 1/4"	SHE10615K

**MOTORES / ENGINES / MOTORI**  
220, 270, 300, 350



**KITS REPARACIÓN  
REPAIR KIT  
KIT RIPARAZIONE**

Ref.	R.O. OEM
SHE10615K	RP061017

**MOTORES / ENGINES / MOTORI**  
GM V-Belt

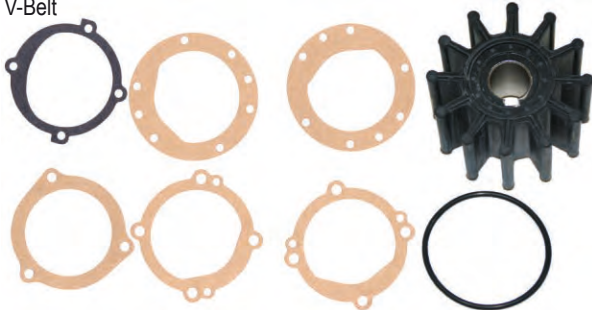

**NEW**

Ref.	R.O. OEM
SHE09959K	RP061015

**MOTORES / ENGINES / MOTORI**  
Ford



**NEW**

Ref.	R.O. OEM
JOH09-1027B	



**NEW**

**TERMOSTATO  
THERMOSTAT  
TERMOSTATO**

**KITS TERMOSTATO  
THERMOSTAT KITS  
KIT TERMOSTATI**

Ref.	R.O. OEM	
REC8M0089715	R026002E	140°

**MOTORES / ENGINES / MOTORI**  
FORD 302/351 CID



**NEW**

Ref.	R.O. OEM
REC97361	RP026002E

**MOTORES / ENGINES / MOTORI**  
FORD 302/351 CID



**NEW**

**BOMBA COMBUSTIBLE  
FUEL PUMP  
POMPA BENZINA**

Ref.	R.O. OEM
REC62092T	

**MOTORES / ENGINES / MOTORI**  
FORD V8, 302



**NEW**

**JUNTA BOMBA  
PUMP GASKET  
GUARNIZIONE POMPA**

Ref.	R.O. OEM
REC27-34213	3705042



**NEW**

**FILTROS ACEITE**  
**OIL FILTERS**  
**FILTRI OLIO**

Ref.	R.O. OEM
REC35-06003	R077002



Ref.	R.O. OEM
REC35-06007	R077001



Ref.	R.O. OEM
REC3850559	



Ref.	R.O. OEM
REC3517857	



**CARBURADORES**  
**CARBURETORS**  
**CARBURATORI**

**KITS CARBURADOR**  
**CARBURETOR KITS**  
**KIT CARBURATORE**

Ref.	R.O. OEM
REC1396-4656	RN0116 RN0116-2



MOTORES / ENGINES / MOTORI  
155, 165, 175, 185 302" (5.0L)

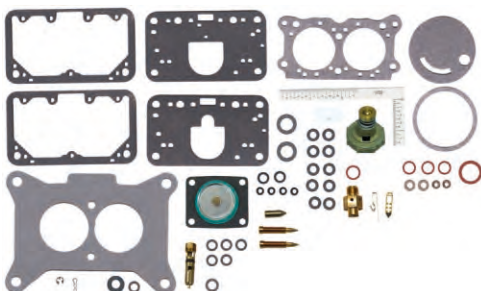

Ref.	R.O. OEM
REC1396-5238	RN0118 RN0120



MOTORES / ENGINES / MOTORI  
215, 255, 215 302" (5.0L) 351" (5.8L)

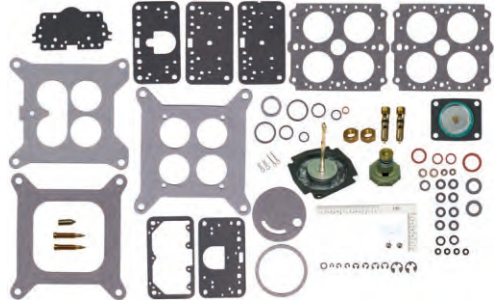

**CHOKE TERMOSTATO**  
**THERMOSTAT CHOKE**  
**CHOKE TERMOSTATO**

Ref.	R.O. OEM
REC1396-4148	RN0067



HOLLEY



**SENSORES**  
**SENSORS**  
**SENSORI**

**PRESIÓN DE ACEITE**  
**OIL PRESSURE**  
**PRESIONE DELL'OLIO**

Ref.	R.O. OEM
REC8M0068784	RO200001 80 PSI



**SENSOR DE PICADO**  
**KNOCK SENSOR**  
**SENSORE DI ANTICIPO**

Ref.	R.O. OEM
REC22024631	R020027



**PLEASURECRAFT**

**SENSOR ÁRBOL DE LEVAS  
CAMSHAFT SENSOR  
SENSORE ALBERO A CAMME**

Ref.	R.O. OEM
REC892615002	R020035A



**IAC**

Ref.	R.O. OEM
REC803149	R084003



**ENCENDIDO  
IGNITION  
ACCENSIONE**

**TAPAS DISTRIBUIDOR  
DISTRIBUTOR CAPS  
CALOTTE SPINTEROGENI**

Ref.	R.O. OEM
REC392-9766	RA108003



Ref.	R.O. OEM
REC392-9086T	



Ref.	R.O. OEM
REC835702	RA108002



Ref.	R.O. OEM
REC982209	R108001



Ref.	R.O. OEM
REC898253T22	RA108009



**MOTORES / ENGINES / MOTORI**  
MP 5.0L, 5.7L (2002-05)



Ref.	R.O. OEM
REC393-4988	



**PLATINO  
POINT  
PUNTINE**

Ref.	R.O. OEM
REC8M6001219	R114002



Ref.	R.O. OEM
REC391-5090	R114001 R114004



Ref.	R.O. OEM
REC71831	



**CONDENSADORES  
CONDENSERS  
CONDENSATORE**

Ref.	R.O. OEM
REC33662	R115002

**NEW**



Ref.	R.O. OEM
REC8M6001217	R115001

**NEW**



Ref.	R.O. OEM
REC64851	

**NEW**



Ref.	R.O. OEM
REC8M6001249	

**NEW**



**ROTORES  
ROTORS  
ROTORI**

Ref.	R.O. OEM
REC898253013	R103011

**NEW**

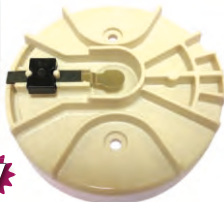

**MOTORES / ENGINES / MOTORI**  
MP 5.0L, 5.7L (2002-05)

Ref.	R.O. OEM
REC3853801	R103004

**NEW**



Ref.	R.O. OEM
REC89825302	R103001

**NEW**



Ref.	R.O. OEM
REC834975	R103003

**NEW**



**KITS DE ENCENDIDO  
TUNE UP KITS  
KIT ACCENSIONE**

Ref.	R.O. OEM
REC391-5090Q1	

**NEW**



REC89825302 + REC391-5090 + REC8M6001217

Ref.	R.O. OEM
REC392-6324Q1	

**NEW**



REC3853801 + REC8M6001219 + REC8M6001249

**DISTRIBUIDORES  
DISTRIBUTORS  
SPINTEROGENI**

Ref.	R.O. OEM
REC392-6316	RA107001

**NEW**

**MOTORES / ENGINES / MOTORI**  
MALLORY YL512CV  
FORD 302 CID V8



Ref.	R.O. OEM
REC392-6330	

**NEW**

**MOTORES / ENGINES / MOTORI**  
MALLORY YL554CV  
FORD 351 CID V8



Ref.	R.O. OEM
REC17177A1	

**NEW**

**MOTORES / ENGINES / MOTORI**  
MALLORY YL624MW  
GM V8



Ref.	R.O. OEM
REC805222A1	RA107039E

**MOTORES / ENGINES / MOTORI**  
V8 264, 454, 502

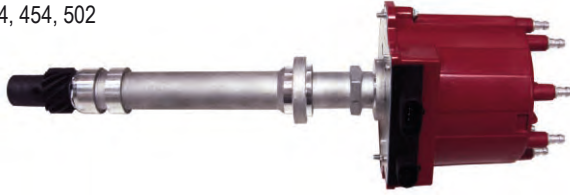

**NEW**

Ref.	R.O. OEM
REC807964A1	

**MOTORES / ENGINES / MOTORI**  
V6



**NEW**

Ref.	R.O. OEM
REC21622232	

**MOTORES / ENGINES / MOTORI**  
V8

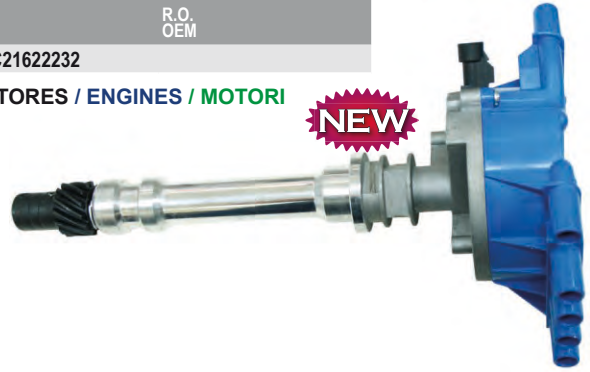

**NEW**

**KITS DE CONVERSIÓN ELECTRÓNICO**  
**ELECTRONIC CONVERSION KITS**  
**KIT CONVERSIONE ELETTRONICO**

- Sustituyen condensadores y contactos por componentes electrónicos.
- Usa bobina, tapa y rotor estandar.
- De fácil instalación, una pieza y dos cables.
- Precisión entre 1/4" calibrado de 0 a 8000 rpm.
- To substitute condensers for electronic devices
- Uses standard.coil, cap & rotor
- Easy installation; one piece, two cables.
- Precisely calibrated between 1/4" from 0 to 8000
- Sostituiscue condensatori e contatti per componenti elettronici.
- Utilizza bobina, calotta e rotore standard.
- Facile installazione, un pz e due cavi.
- Precisione 1/4" calibrato da 0 a 8000.

Ref.	R.O. OEM
REC26904	

**MOTORES / ENGINES / MOTORI**  
Para la mayoría de distribuidores de 8 cil.  
Mallory YL o YD con rotación reloj y contrareloj.  
For most Mallory V8 distributors  
Per al maggior parte degli spinterogeni per 8 cilindri Mallory YL o YD con rotazione oraria e antioraria



**NEW**

Ref.	R.O. OEM
REC26902	

**MOTORES / ENGINES / MOTORI**  
Para la mayoría de distribuidores Prestolite V8 con tornillo en la tapa  
For most Prestolite V8 distributors with screw on cap  
Per al maggior parte degli spinterogeni Prestolite V8 con vite nella calotta.



**NEW**

Ref.	R.O. OEM
REC26901	

**MOTORES / ENGINES / MOTORI**  
Para la mayoría de distribuidores de 6 cilindros Delco.  
For most Delco 6 cyl. distributors  
Per al maggior parte degli spinterogeni per 6 cilindri Delco.



**NEW**

Ref.	R.O. OEM
REC26903	

**MOTORES / ENGINES / MOTORI**  
Presolite V8



**NEW**

Ref.	R.O. OEM
REC18-5295	

**MOTORES / ENGINES / MOTORI**  
Para la mayoría de distribuidores de 4 cilindros Prestolite.  
For most Prestolite 4 cyl. distributors  
Per al maggior parte degli spinterogeni per 4 cilindri Prestolite.



**NEW**

## BOBINAS ENCENDIDO IGNITION COILS BOBINE ACCENSIONE

Ref.	R.O. OEM
REC300-00879	

No usa resistencia externa.  
Utilizar con encendido Prestolite.  
Use without external resistor & Prestolite ignition  
Non utilizza resistenza esterna. Utilizzare con spinterogeno Prestolite

**NEW**



Ref.	R.O. OEM
REC1463-9382	R117001

Resistencia externa.  
Utilizar con encendido convencional.  
External resistor. Use with conventional ignition  
Resistenza esterna. Utilizzare con accensione convenzionale

**NEW**



Ref.	R.O. OEM
REC3861267	R117012

**NEW**



## JUEGOS DE CABLE PARA BUJÍAS DE ALTO RENDIMIENTO HD SPARK PLUG WIRE SET KIT CAVI CANDELE ALTE PRESTAZIONI

Ref	MODELO MODEL MOELLO	ARRANQUE CONVENCIONAL IGNITION CONVENTIONAL AVVIAMENTO CONVENZIONALE	ARRANQUE ELECTRONICO IGNITION ELECTRONIC AVVIAMENTO ELETTRONICO	CYL
REC15-604	262 CID (4.3L)	✓		6
REC15-801	V8 (Tapas de terminal / Top terminal caps / Coperchio terminali)	✓		8
REC15-806	V8 (Mallory lateral de terminal / Side terminal caps / Coperchio laterali)	✓		8
MAG15-809	454 (7.4L)		✓	8



## MOTORES DE ARRANQUE STARTERS MOTORINO D'AVVIAMENTO

Ref.	R.O. OEM	DIENTES TOOTH DENTI
PH140-0022	RA122008 9000888	12V 1.4kw 9

MOTORES / ENGINES / MOTORI  
GM & Ford

**NEW**



Ref.	R.O. OEM	DIENTES TOOTH DENTI
PH140-0022-CCW	RA122009	12V 1.4kw 9

305 5.0L  
Contrarrotación o montaje en campana  
CCW Starter  
Controrrotante o montato nella campana

**NEW**





PLEASURECRAFT

Ref.	R.O. OEM
PH140-0004	RA122001 987811 RK122014



**MOTORES / ENGINES / MOTORI**  
302 5.0L

Con 2 tornillos de anclaje  
2 mounting holes  
Con 2 viti di supporto

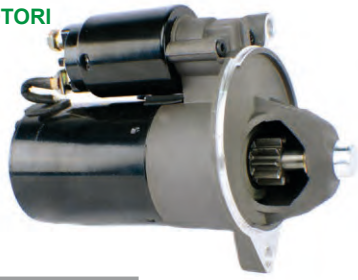

Ref.	R.O. OEM
PH140-0004-CCW	



**MOTORES / ENGINES / MOTORI**  
302 5.0L

Contrarrotación.  
Counter clockwise starter  
Controrrotante.

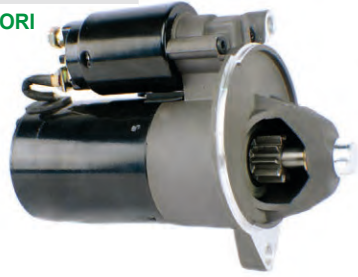

Ref.	R.O. OEM	DIENTES TOOTH DENTI
PH140-0013		9



**MOTORES / ENGINES / MOTORI**  
231 3.8L (1981-95)  
305 5.0L (1976-95)

Motor de arranque 4 en línea  
(Tornillos sujeción misma altura)  
Duty standard rotation 4 in line.  
In line mounting holes.  
4 in rete (viti di supporto parallele)



Ref.	R.O. OEM	DIENTES TOOTH DENTI
PH140-0015		9

**MOTORES / ENGINES / MOTORI**  
305 5.0L (1976-95)



Ref.	R.O. OEM
PH140-0017-D	

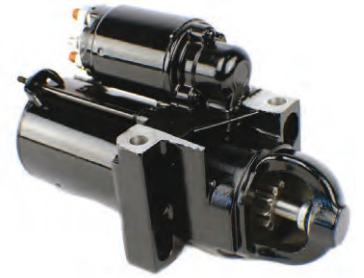

ALTERNADORES  
ALTERNATORS  
ALTERNATORI

Ref.	R.O. OEM
PH300-0007	12V 63A



**MOTORES / ENGINES / MOTORI**  
231 3.8L (1981-95)  
305 5.0L (1976-95)

Autoexcitante. Polea simple.  
Self-exciting. Single pulley.  
Auto-eccitante. Puleggia singola.



Ref.	R.O. OEM
PH300-0013	RA097002 RA097003 RA097006



Polea de transmisión  
Drive pulley  
Puleggia di azionamento



Ref.	R.O. OEM
PH300-0010	12V 55A



Regulador interno. Polea simple.  
Internal regulator. Single pulley.  
Regolatore interno. Puleggia singola.



Ref.	R.O. OEM
PH300-0014	12V 65A



Regulador interno. Polea simple.  
Internal regulator. Single pulley.  
Regolatore interno. Puleggia singola.



Ref.	R.O. OEM
PH300-0032	RA097007B RA097007L 12V 70A

Regulador interno. Polea simple 65 mm.  
Internal regulator. Single pulley 65 mm.  
Regolatore interno. Puleggia singola 65 mm.



Ref.	R.O. OEM
PH300-0041	RA097007 12V 70A

Regulador interno. Polea serpentina 65 mm.  
Internal regulator. Serpentine pulley 65 mm.  
Regolatore interno. Puleggia serpentine 65 mm.



**SOLENOIDES**  
**SOLENOID**  
**SOLENOIDE**

Ref.	R.O. OEM
PH375-0027	R130001



**POWER TRIM**

**LATIGUILLOS TRIM**  
**TRIM HOSES**  
**TUBI TRIM**

Ref.	R.O. OEM
REC32-86036	R085035



**ADAPTADOR GOMA**  
**BUSHING**  
**ADATTATORE IN GOMMA**

Ref.	R.O. OEM
REC23-99291	R094020A



**COMPONENTES DE COLA**  
**GEARHOUSING COMPONENTS**  
**COMPONENTI PIEDE**

**CIERRES HÉLICE**  
**PROP HARDWARE**  
**CHIUSURA ELICA**

**TOPES**  
**THRUST WASHERS**  
**FERMI**



Ref.	R.O. OEM
REC12-835467Q01	R096116

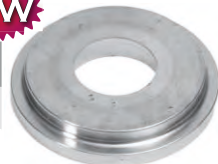

**ARANDELA CIERRE**  
**LOCKING WASHER**  
**RONDELLA FERMO**



Ref.	R.O. OEM
REC897367	R096081



**TUERCA**  
**NUTS**  
**DADO**



Ref.	R.O. OEM
REC90301-ZW1-003	R017066



**ARANDELA TUERCA**  
**TAB WASHER**  
**RONDELLA DADO**



Ref.	R.O. OEM
REC90508-ZW1-003	R096117



**RENAULT COUACH**

**COMPONENTES  
PARTS  
COMPONENTI**

**FILTRO ACEITE  
OIL FILTER  
FILTRO OLIO**

REF	R.O. OEM	MOTOR ENGINE MOTORE
RECFF425		2.60-3.90
RECFF536		RCD16
RECFF436		RC75D
RECFF124		RC80D
RECFF346		RC100JET
RECFF477		RC130D
RECFF143		RC140D-RC210D
REC3517857		4 CYL Sterndrive



RECFF425

RECFF536

REC3517857



RECFF436

RECFF346

RECFF477



RECFF143

RECFF124

**IMPULSORES  
IMPELLER  
GIRANTE**

R.O. OEM	PALAS BLADES PALE	JOHNSON	CEF	RECMAR	MEDIDAS (mm) MEASURES (mm) MISURE (mm)		
					A	B	C
48300006	8		CEF500128		17	66	32
48300007							
48300008	8		CEF500122T		17	65	48,6
48300037	6		CEF500127		10	50,8	22,1
48300055							
RC320D	8	JOH09-1028B	CEF500106GT	REC3841697	14,29	65	50,2

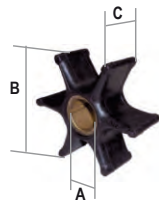

REC3841697



CEF500128



CEF500122T



CEF500127

ÁNODOS DE ZINC  
ZINC ANODES  
ANODI IN ZINCO

REF	R.O. OEM	ROSCA TAPÓN PLUG THREAD PASSO TAPPO	Ø mm	LONGITUD LENGTH LUNGHEZZA	ROSCA THREAD PASSO
TEN02090		Sólo ánodo Only anode Solo anodo	15	22	12
TEN02090T		18 x 15	15	22	12



Ref.	R.O. OEM
TEN01804	



ZN	(KG / LB)	Ø EJE Ø SHAFT Ø ASSE	h (mm)	m (mm)	Ø (mm)
TEN01801	0,075 kg / 0.17 lb	22 - 25	36	16 x 2	27
TEN01802	0,145 kg / 0.32 lb	28 - 34	47	20 x 2,5	35
TEN01803	0,28 kg / 0.62 lb	40	48	28 x 2,5	41
TEN00490	0,31 kg / 0.68 lb	40	50	M20	40
TEN00491	0,3 kg / 0.66 lb	40	50	M24	40
TEN00492	0,295 kg / 0.65 lb	40	50	M27	40
TEN00493	0,265 kg / 0.58 lb	40	50	M30	40
TEN00494	0,31 kg / 0.68 lb	40	52	20 x 2	40
TEN00495	0,28 kg / 0.62 lb	40	50	26 x 2	40

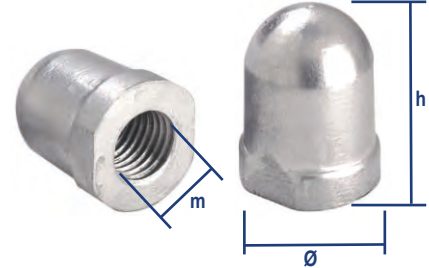

SOLE DIESEL

ÁNODOS DE ZINC  
ZINC ANODES  
ANODI IN ZINCO

REF	R.O. OEM	kg / lbs	Ø EJE SHAFT Ø Ø ASSE mm	H mm	Ø mm	Ø1 mm
TEN00400SOLE/1	40030092	0,120 / 0.26	30	39	24	32
TEN00400SOLE/2	50035092	0,20 / 0.44	35	46	26	37
TEN00400SOLE/3	40045092	0,40 / 0.88	45	60	36	47
TEN00400SOLE/4	40050092	0,56 / 1.23	50	70	45	55

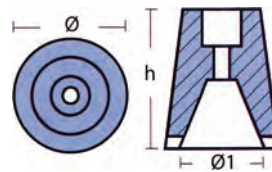

IMPULSORES  
IMPELLER  
GIRANTE

R.O. OEM	PALAS BLADES PALE	JOHNSON	CEF	RECMAR	MEDIDAS (mm) MEASURES (mm) MISURE (mm)			
					A	B	C	
347.11.008	8	SM-75 (72 HP) SM-90 (88 HP) HS-121 (115 HP) HS-270 (270 HP) 150 (165 HP)	JOH09-1028B	CEF500106GT	REC3841697	14,29	65	50,2
351.11.008	12	MINI - 50	JOH09-1027B	CEF500107T	REC21213660	14,29	57	31,6
312.11.008	6	MINI - 11 / 17 / 23 MINI - 26 / 34 / 48		CEF500123X		12	52	25
321.11.008	6	MINI-11 (11 HP) MINI-17 (16 HP) MINI-26 (25 HP) MINI-34 (31 HP) MINI-48 (45 HP)		CEF500131X		10	39,6	19,2

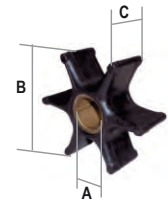

REC21213660



CEF500123X



CEF500131X

# ÁNODOS DE ZINC ZINC ANODES ANODI IN ZINCO

REF	R.O. OEM	kg / lbs	L mm	a mm	b mm	h mm	h1 mm	i mm	Ø1 mm	Ø2 mm
TEN03510	ZINK15SC	1,00 / 2.20	152	52	68	23	29	80	11	11 x 15
TEN03511	ZINK25SC	2,40 / 5.29	250	55	75	21	37	40	11	11 x 15



TEN03510

TEN03511

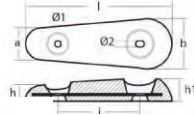

REF	R.O. OEM	kg / lbs	Ø mm	h mm	i mm	Ø1 mm	Ø1 mm	Ø3 mm
TEN03506	BP1126 SET0149	0,145 / 0.32	50	17	37	43	15	5,5

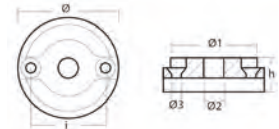

REF	R.O. OEM	kg / lbs	Ø mm	a mm	b mm	h mm	Ø1 mm	Ø2 mm	Ø3 mm
TEN03512		0,650 / 1.43	75	25	7	47	8,5	42	55



REF	R.O. OEM	kg / lbs	Ø mm	h mm	i mm	Ø1 mm	Ø1 mm	Ø3 mm
TEN03507	BP1185 SET0150	0,154 / 0.34	56	15	40	44	15	5

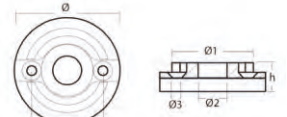

REF	R.O. OEM	kg / lbs	Ø mm	c mm	h mm	h1 mm	Ø1 mm	Ø2 mm	Ø3 mm
TEN03508	BP1210 SET0152	0,380 / 0.84	50	24	41	17	10,5	6,5	33

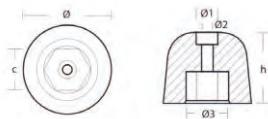

REF	R.O. OEM	kg / lbs	Ø mm	a mm	h mm	h1 mm	Ø1 mm	Ø2 mm	Ø3 mm
TEN03500	BP195E SET151	0,480 / 1.06	60	24	17	42	6,5	30	12

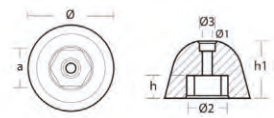

REF	R.O. OEM	kg / lbs	Ø mm	a mm	h mm	Ø1 mm	Ø1 mm
TEN03509	BP195	0,385 / 0.85	53	28	47	11	1

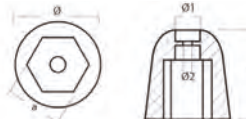

REF	R.O. OEM	kg / lbs	Ø mm	l mm	a mm	b mm	h mm	h1 mm
TEN03502	BP129 SET153	0,065 / 0.14	6,5	41	20	17	24	17



REF	R.O. OEM	kg / lbs	Ø mm	h mm	i mm	Ø1 mm	Ø1 mm	Ø3 mm
TEN03505	BP1221 SET0148	0,040 / 0.09	38	10	29	32	17	4,5

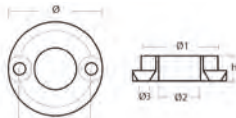

REF	R.O. OEM	kg / lbs	Ø mm	h mm	Ø1 mm	Ø2 mm	Ø3 mm
TEN03503		1,050 / 2.31	79	45	11	46	34

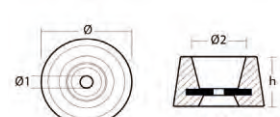

REF	R.O. OEM	kg / lbs	Ø mm	h mm	Ø1 mm	Ø2 mm	Ø3 mm	
TEN00220	ZINK15C	1,000 / 2.20	148	58	27	80	31	11 x 15
TEN00221	ZINK25C	2,300 / 5.07	247	63	30	140	30	13 x 25
TEN00222		2,700 / 5.95	290	53	33	200	32	13 x 25
TEN00223	ZINK35C	4,500 / 9.92	350	68	36	200	38	13 x 25

**NEW**



**IMPULSORES  
IMPELLER  
GIRANTE**

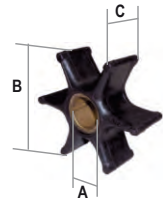

R.O. OEM	PALAS BLADES PALE	JOHNSON	CEF	RECMAR	MEDIDAS (mm) MEASURES (mm) MISURE (mm)		
					A	B	C
IMP00301	8	JOH09-1028B	CEF500106GT	<b>REC3841697</b>	14,29	65	50,2
IMP00201	12	JOH09-1027B		<b>REC21213660</b>	14,29	57	31,6
IMP00101	6		CEF500129	<b>REC22779-0001</b>	12,75	50,8	22,1
IMP00701	10		CEF500146X		12,17	51,8	22
STM8061	6	JOH09-810B	CEF500101X	<b>REC653-0001</b>	12,17	50,8	22,1



REC3841697



REC21213660



REC22779-0001



REC653-0001



CEF500146X

**COMPONENTES  
PARTS  
COMPONENTI**

**FILTRO ACEITE  
OIL FILTER  
FILTRO OLIO**

Ref.	R.O. OEM
REC35595	35595



Ref.	R.O. OEM
REC36918	36918



**KITS CARBURADOR  
CARBURATOR KIT  
KIT CARBURATORE**

Ref.	R.O. OEM
REC36450	36450

**MOTORES / ENGINES / MOTORI**  
6.5, 6.4, 4.9, 8.0 (TWG)  
8.5, 6.5, 12.5, 10.0, 15.0, 12.0 (BTG)  
16.0, 20.0, 25.0 (BEG)

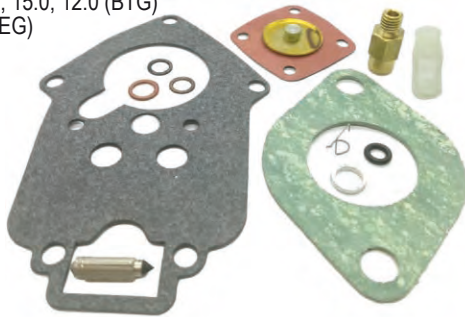

Ref.	R.O. OEM
REC38100	38100

**MOTORES / ENGINES / MOTORI**  
3.0, 4.0, 4.5, 3.75 (BCG)  
4.5, 3.75 (BCGB)  
4.5, 3.75 (BCGTC)  
5.0, 4.2, 6.5, 4.8, 7.0 (BCG)



**MOTOR DE ARRANQUE  
STARTER  
MOTORINO D'AVVIAMENTO**

Ref.	R.O. OEM	DIENTES TOOTH DENTI
PH140-0022	33486	12V 1.4 Kw 9

**MOTORES / ENGINES / MOTORI**  
6.5, 8.0, 11.0 (TWG) 4 Cyl Gas



**NEW**

**ALTERNADOR  
ALTERNATOR  
ALTERNATORE**

Ref.	R.O. OEM
ARC86050	30594 12V 50A



**ÁNODOS DE ZINC  
ZINC ANODES  
ANODI IN ZINCO**

Ref.	R.O. OEM
CME0	11885



# BOMBA DE AGUA WATER PUMP POMPA ACQUA

Ref.	R.O. OEM	Ø ENTRADA Ø INLET Ø ENTRATA	Ø SALIDA Ø OUTLET Ø USCITA	IMPULSOR IMPELLER GIRANTE
SHER30G-1	24102	1/2"	1/2"	REC10077K



Ref.	R.O. OEM	Ø ENTRADA Ø INLET Ø ENTRATA	Ø SALIDA Ø OUTLET Ø USCITA	IMPULSOR IMPELLER GIRANTE
SHER10870G	11353	3/8"	3/8"	REC3854286



Ref.	R.O. OEM	Ø ENTRADA Ø INLET Ø ENTRATA	Ø SALIDA Ø OUTLET Ø USCITA	IMPULSOR IMPELLER GIRANTE
REC48080	48080 37431 33636	3/8" NPT	3/8" NPT	REC653-0001

**NEW**



# IMPULSORES IMPELLER GIRANTE

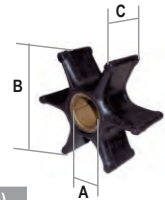

R.O. OEM	PALAS BLADES PALE	SHERWOOD	JOHNSON	CEF	RECMAR	MEDIDAS (mm) MEASURES (mm) MISURE (mm)		
						A	B	C
302875	12	SHE09000K		CEF500165	REC09000K	15,95	62,2	22,4
11418 11907 33104	12	SHE09959K		CEF500103T	REC3854286	15,9	62	31,7
13930	12	SHE10615K		CEF500120T	REC10615K	15,9	65,2	41,3
11764 33100	12	SHE10077K		CEF500166	REC10077K	12,8	56,6	19,8
48080 37431	6		JOH09-810B	CEF500101X	REC653-0001	12,17	50,8	22,1



REC09000K



REC3854286



REC10615K



REC10077K



REC653-0001



**BOMBA DE AGUA**  
**WATER PUMP**  
**POMPA ACQUA**

Ref.	Ø ENTRADA Ø INLET Ø ENTRATA	Ø SALIDA Ø OUTLET Ø USCITA	IMPULSOR IMPELLER GIRANTE
SHEG702	1"	1"	SHE10077K

**NEW**



Ref.	Ø ENTRADA Ø INLET Ø ENTRATA	Ø SALIDA Ø OUTLET Ø USCITA	IMPULSOR IMPELLER GIRANTE
SHEG8002	3/8" NPT	3/8" NPT	SHE08000K

**NEW**



Ref.	Ø ENTRADA Ø INLET Ø ENTRATA	Ø SALIDA Ø OUTLET Ø USCITA	IMPULSOR IMPELLER GIRANTE	KIT MENOR MINOR KIT KIT MINORE
SHEP1016	1 1/2"	1 1/2"	SHE10615K	SHE23976

**NEW**



Ref.	Ø ENTRADA Ø INLET Ø ENTRATA	Ø SALIDA Ø OUTLET Ø USCITA	IMPULSOR IMPELLER GIRANTE	KIT MENOR MINOR KIT KIT MINORE	KIT MAYOR MAJOR KIT KIT MAGGIORE
SHER30G-1	1 1/2"	1 1/2"	SHE10077K	SHE10996	SHE24025



Ref.	Ø ENTRADA Ø INLET Ø ENTRATA	Ø SALIDA Ø OUTLET Ø USCITA	IMPULSOR IMPELLER GIRANTE	KIT MENOR MINOR KIT KIT MINORE	KIT MAYOR MAJOR KIT KIT MAGGIORE
SHEP1716C SHEP1722C	2"	1 3/4"	SHE17000K	SHE25124	SHE25122



Ref.	Ø ENTRADA Ø INLET Ø ENTRATA	Ø SALIDA Ø OUTLET Ø USCITA	IMPULSOR IMPELLER GIRANTE	KIT MENOR MINOR KIT KIT MINORE	KIT MAYOR MAJOR KIT KIT MAGGIORE
SHEP1727C SHEP1730C			SHE17000K	SHE25124	SHE25122

Codos con brida  
Flanged Elbows  
Gomiti con fascetta



Ref.	Ø ENTRADA Ø INLET Ø ENTRATA	Ø SALIDA Ø OUTLET Ø USCITA	IMPULSOR IMPELLER GIRANTE	KIT MENOR MINOR KIT KIT MINORE	KIT MAYOR MAJOR KIT KIT MAGGIORE
SHEG9901	1 1/4"	1"	SHE09959K	SHE23979	SHE12665

Codos con brida  
Flanged Elbows  
Gomiti con fascetta



Ref.	Ø ENTRADA Ø INLET Ø ENTRATA	Ø SALIDA Ø OUTLET Ø USCITA	IMPULSOR IMPELLER GIRANTE	KIT MENOR MINOR KIT KIT MINORE	KIT MAYOR MAJOR KIT KIT MAGGIORE
SHEG9903	1 1/4"	1"	SHE09959K	SHE23979	SHE12665

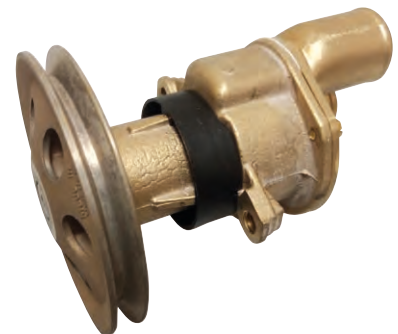

# SHERWOOD

Ref.	Ø ENTRADA Ø INLET Ø ENTRATA	Ø SALIDA Ø OUTLET Ø USCITA	IMPULSOR IMPELLER GIRANTE	KIT MENOR MINOR KIT KIT MINORE	KIT MAYOR MAJOR KIT KIT MAGGIORE
------	-----------------------------------	----------------------------------	---------------------------------	--------------------------------------	--

SHEG155 1 1/2" 1 1/2" SHE15000K SHE23980 SHE23981



Ref.	Ø ENTRADA Ø INLET Ø ENTRATA	Ø SALIDA Ø OUTLET Ø USCITA	IMPULSOR IMPELLER GIRANTE	KIT MENOR MINOR KIT KIT MINORE	KIT MAYOR MAJOR KIT KIT MAGGIORE
------	-----------------------------------	----------------------------------	---------------------------------	--------------------------------------	--

SHEG151 1 1/2" 1 1/2" SHE15000K SHE23980 SHE23981



Ref.	Ø ENTRADA Ø INLET Ø ENTRATA	Ø SALIDA Ø OUTLET Ø USCITA	IMPULSOR IMPELLER GIRANTE	KIT MENOR MINOR KIT KIT MINORE	KIT MAYOR MAJOR KIT KIT MAGGIORE
------	-----------------------------------	----------------------------------	---------------------------------	--------------------------------------	--

SHER991 1 1/4" 1 1/4" SHE09959K SHE18655



Ref.	Ø ENTRADA Ø INLET Ø ENTRATA	Ø SALIDA Ø OUTLET Ø USCITA	IMPULSOR IMPELLER GIRANTE	KIT MENOR MINOR KIT KIT MINORE	KIT MAYOR MAJOR KIT KIT MAGGIORE
------	-----------------------------------	----------------------------------	---------------------------------	--------------------------------------	--

SHEE35 1" 1" SHE10615K SHE10999 SHE11068



Ref.	Ø ENTRADA Ø INLET Ø ENTRATA	Ø SALIDA Ø OUTLET Ø USCITA	IMPULSOR IMPELLER GIRANTE	KIT MENOR MINOR KIT KIT MINORE	KIT MAYOR MAJOR KIT KIT MAGGIORE
------	-----------------------------------	----------------------------------	---------------------------------	--------------------------------------	--

SHEP1014 1 1/4" 1 1/4" SHE10615K SHE23976 SHE25029



Ref.	Ø ENTRADA Ø INLET Ø ENTRATA	Ø SALIDA Ø OUTLET Ø USCITA	IMPULSOR IMPELLER GIRANTE	KIT MENOR MINOR KIT KIT MINORE	KIT MAYOR MAJOR KIT KIT MAGGIORE
------	-----------------------------------	----------------------------------	---------------------------------	--------------------------------------	--

SHEG21 1" 1" SHE09959K SHE23979 SHE12665



Ref.	Ø ENTRADA Ø INLET Ø ENTRATA	Ø SALIDA Ø OUTLET Ø USCITA	IMPULSOR IMPELLER GIRANTE	KIT MENOR MINOR KIT KIT MINORE	KIT MAYOR MAJOR KIT KIT MAGGIORE
------	-----------------------------------	----------------------------------	---------------------------------	--------------------------------------	--

SHEP176X 1 1/2" 1 3/4" SHE17000K SHE23973 SHE23975



Ref.	Ø ENTRADA Ø INLET Ø ENTRATA	Ø SALIDA Ø OUTLET Ø USCITA	IMPULSOR IMPELLER GIRANTE	KIT MENOR MINOR KIT KIT MINORE	KIT MAYOR MAJOR KIT KIT MAGGIORE
------	-----------------------------------	----------------------------------	---------------------------------	--------------------------------------	--

SHEP1710C SHE17000K SHE25123 SHE25121



Ref.	Ø ENTRADA Ø INLET Ø ENTRATA	Ø SALIDA Ø OUTLET Ø USCITA	IMPULSOR IMPELLER GIRANTE	KIT MENOR MINOR KIT KIT MINORE	KIT MAYOR MAJOR KIT KIT MAGGIORE
------	-----------------------------------	----------------------------------	---------------------------------	--------------------------------------	--

SHEG2902X 3 3/4" 3 3/4" SHE29000K SHE25146 SHE25147



Ref.	Ø ENTRADA Ø INLET Ø ENTRATA	Ø SALIDA Ø OUTLET Ø USCITA	IMPULSOR IMPELLER GIRANTE	KIT MENOR MINOR KIT KIT MINORE	KIT MAYOR MAJOR KIT KIT MAGGIORE
------	-----------------------------------	----------------------------------	---------------------------------	--------------------------------------	--

SHEG2904X SHE29000K SHE25146 SHE25148

Codos no incluidos  
Elbows not included  
Gomito non incluso

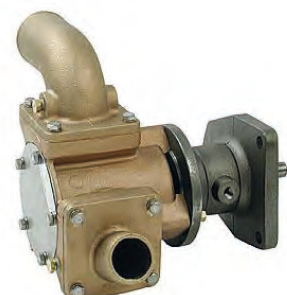

**SHERWOOD**

Ref.	Ø ENTRADA Ø INLET Ø ENTRATA	Ø SALIDA Ø OUTLET Ø USCITA	IMPULSOR IMPELLER GIRANTE	KIT MENOR MINOR KIT KIT MINORE	KIT MAYOR MAJOR KIT KIT MAGGIORE
SHEG3001X	3/4"	3/4"	SHE30000K	SHE25017	SHE25154



Ref.	Ø ENTRADA Ø INLET Ø ENTRATA	Ø SALIDA Ø OUTLET Ø USCITA	IMPULSOR IMPELLER GIRANTE	KIT MENOR MINOR KIT KIT MINORE	KIT MAYOR MAJOR KIT KIT MAGGIORE
SHEP1732C			SHE17000K	SHE25123	SHE25121



Ref.	Ø ENTRADA Ø INLET Ø ENTRATA	Ø SALIDA Ø OUTLET Ø USCITA	IMPULSOR IMPELLER GIRANTE	KIT MENOR MINOR KIT KIT MINORE	KIT MAYOR MAJOR KIT KIT MAGGIORE
SHEM71	1 1/4"	1 1/4"	SHE10615K	SHE23976	SHE23977



Ref.	Ø ENTRADA Ø INLET Ø ENTRATA	Ø SALIDA Ø OUTLET Ø USCITA	IMPULSOR IMPELLER GIRANTE	KIT MENOR MINOR KIT KIT MINORE	KIT MAYOR MAJOR KIT KIT MAGGIORE
SHEGC1 SHEGC5	1 1/2"	1 1/2"	SHE15000K	SHE23980	SHE23981



Ref.	Ø ENTRADA Ø INLET Ø ENTRATA	Ø SALIDA Ø OUTLET Ø USCITA	IMPULSOR IMPELLER GIRANTE	KIT MENOR MINOR KIT KIT MINORE	KIT MAYOR MAJOR KIT KIT MAGGIORE
SHEP2708X			SHE27000K	SHE25125	SHE25126



Ref.	Ø ENTRADA Ø INLET Ø ENTRATA	Ø SALIDA Ø OUTLET Ø USCITA	IMPULSOR IMPELLER GIRANTE	KIT MENOR MINOR KIT KIT MINORE	KIT MAYOR MAJOR KIT KIT MAGGIORE
SHEG157			SHE15000K	SHE23980	SHE23981



Ref.	Ø ENTRADA Ø INLET Ø ENTRATA	Ø SALIDA Ø OUTLET Ø USCITA	IMPULSOR IMPELLER GIRANTE	KIT MENOR MINOR KIT KIT MINORE	KIT MAYOR MAJOR KIT KIT MAGGIORE
SHEG2603X			SHE26000K	SHE24841	SHE24842

Codos no incluidos  
Elbows not included  
Gomito non incluso



Ref.	Ø ENTRADA Ø INLET Ø ENTRATA	Ø SALIDA Ø OUTLET Ø USCITA	IMPULSOR IMPELLER GIRANTE	KIT MENOR MINOR KIT KIT MINORE	KIT MAYOR MAJOR KIT KIT MAGGIORE
SHEG2903X			SHE29000K	SHE25044	SHE25045

Codos no incluidos  
Elbows not included  
Gomito non incluso



Ref.	Ø ENTRADA Ø INLET Ø ENTRATA	Ø SALIDA Ø OUTLET Ø USCITA	IMPULSOR IMPELLER GIRANTE	KIT MENOR MINOR KIT KIT MINORE	KIT MAYOR MAJOR KIT KIT MAGGIORE
SHEG65	3/4" NPT	3/4" NPT	SHE09959K		SHE09959K



Ref.	Ø ENTRADA Ø INLET Ø ENTRATA	Ø SALIDA Ø OUTLET Ø USCITA	IMPULSOR IMPELLER GIRANTE	KIT MENOR MINOR KIT KIT MINORE	KIT MAYOR MAJOR KIT KIT MAGGIORE
SHERPBC	1" NPT	1" NPT	SHE10615K	SHE10999	SHE11068



# SHERWOOD

Ref.	Ø ENTRADA Ø INLET Ø ENTRATA	Ø SALIDA Ø OUTLET Ø USCITA	IMPULSOR IMPELLER GIRANTE	KIT MENOR MINOR KIT KIT MINORE	KIT MAYOR MAJOR KIT KIT MAGGIORE
SHEH5	1"	1"	SHE09959K	SHE12980	



Ref.	Ø ENTRADA Ø INLET Ø ENTRATA	Ø SALIDA Ø OUTLET Ø USCITA	IMPULSOR IMPELLER GIRANTE	KIT MENOR MINOR KIT KIT MINORE	KIT MAYOR MAJOR KIT KIT MAGGIORE
SHER30G-1	1/2" NPT	1/2" NPT	SHE10077K	SHE10077K	SHE24025



Ref.	Ø ENTRADA Ø INLET Ø ENTRATA	Ø SALIDA Ø OUTLET Ø USCITA	IMPULSOR IMPELLER GIRANTE	KIT MENOR MINOR KIT KIT MINORE	KIT MAYOR MAJOR KIT KIT MAGGIORE
SHEK75B	1"	1"	SHE09959K	SHE23979	SHE12665



Ref.	Ø ENTRADA Ø INLET Ø ENTRATA	Ø SALIDA Ø OUTLET Ø USCITA	IMPULSOR IMPELLER GIRANTE	KIT MENOR MINOR KIT KIT MINORE	KIT MAYOR MAJOR KIT KIT MAGGIORE
SHEL10B	1 1/4"	1 1/4"	SHE10615K	SHE23976	SHE23977



Ref.	Ø ENTRADA Ø INLET Ø ENTRATA	Ø SALIDA Ø OUTLET Ø USCITA	IMPULSOR IMPELLER GIRANTE	KIT MENOR MINOR KIT KIT MINORE	KIT MAYOR MAJOR KIT KIT MAGGIORE
SHEG1010	1"	1"	SHE10615K	SHE10999	SHE22276



Ref.	Ø ENTRADA Ø INLET Ø ENTRATA	Ø SALIDA Ø OUTLET Ø USCITA	IMPULSOR IMPELLER GIRANTE	KIT MENOR MINOR KIT KIT MINORE	KIT MAYOR MAJOR KIT KIT MAGGIORE
SHER10870G	3/4" NPT	3/4" NPT	SHE09959K	SHE10997	SHE12937



Ref.	Ø ENTRADA Ø INLET Ø ENTRATA	Ø SALIDA Ø OUTLET Ø USCITA	IMPULSOR IMPELLER GIRANTE	KIT MENOR MINOR KIT KIT MINORE	KIT MAYOR MAJOR KIT KIT MAGGIORE
SHEG8001	3/4" NPT	3/4" NPT	SHE08000K		



Ref.	Ø ENTRADA Ø INLET Ø ENTRATA	Ø SALIDA Ø OUTLET Ø USCITA	IMPULSOR IMPELLER GIRANTE	KIT MENOR MINOR KIT KIT MINORE	KIT MAYOR MAJOR KIT KIT MAGGIORE
SHEG906	3/8"	3/8"	SHE09000K		



Ref.	Ø ENTRADA Ø INLET Ø ENTRATA	Ø SALIDA Ø OUTLET Ø USCITA	IMPULSOR IMPELLER GIRANTE	KIT MENOR MINOR KIT KIT MINORE	KIT MAYOR MAJOR KIT KIT MAGGIORE
SHEG907P	3/8" NPT	3/8" NPT	SHE09000K	SHE25195	SHE25196



Ref.	Ø ENTRADA Ø INLET Ø ENTRATA	Ø SALIDA Ø OUTLET Ø USCITA	IMPULSOR IMPELLER GIRANTE	KIT MENOR MINOR KIT KIT MINORE	KIT MAYOR MAJOR KIT KIT MAGGIORE
SHEG910P	3/8" NPT	3/8" NPT	SHE09000K		



MOTORES / ENGINES / MOTORI  
Ford

**GUÍA DE BOMBAS / MOTORES  
APPLICATION GUIDE PUMPS / ENGINE  
GUIDA POMPE / MOTORI**

692

MOTOR ENGINE MOTORE	R.O. OEM	BOMBA PUMP POMPA	ENTRADA INNER ENTRATA	SALIDA OUTLET USCITA	IMPULSOR IMPELLER GIRANTE	KIT MENOR MINOR	KIT MAYOR MAJOR MAGGIORE	DISPOSICIÓN AVAILABLE DISPONIBILE	BOMBA REEMPLAZADA PUMP POMPA RIMPLAZZATA	KIT RETÉN SEAL KIT KIT PARAOLIO	COJINETE BEARING CUSCINETTO	KIT EJE + COJINETE KIT SHAFT + BEARING KIT ASSE + CUSCINETTO
<b>Caterpillar</b>												
3208	9Y1304	P171	40 mm	40 mm	17000K	23973	23975	Obsoleta Obsoleto Obsoleto	P176X	15955	(2) 15951	
3208	7E4115	P176-02	38,1 mm	40 mm	17000K	23973	23975	Blindada Proprietary Blindata	P176X	23799	(2) 15951	
3116	7E3268	P172	40 mm	40 mm	17000K	23973	23975	Obsoleta Obsoleto Obsoleto	P1710C	15955, 15950	(2) 15951	
3116	4P7168	P1710-02	Codos con brida Flanged Elbows Gomiti con fascetta	Codos con brida Flanged Elbows Gomiti con fascetta	17000K	23973	23975	Blindada Proprietary Blindata	P1710C	23799, 21776	(2) 15951	
3126	113-1109	P1726	Codos con brida Flanged Elbows Gomiti con fascetta	Codos con brida Flanged Elbows Gomiti con fascetta	17000K	23973	23975	Blindada Proprietary Blindata	P1726C	15955, 21776	(2) 15951	
3126	152-8392	P1726TC-02	Codos con brida Flanged Elbows Gomiti con fascetta	Codos con brida Flanged Elbows Gomiti con fascetta	17000K			Blindada Proprietary Blindata	P1726TCX	23799, 21776	(2) 15951	
3126	170-6116	P1732-02	Codos con brida Flanged Elbows Gomiti con fascetta	Codos con brida Flanged Elbows Gomiti con fascetta	17000K	23973	23975	Blindada Proprietary Blindata	P1732C	23799, 21776	(2) 15951	
3176	123-0500	G1805	63,5 mm	50,8 mm	18000K	24023	24024	Blindada Proprietary Blindata		19878, 19869		24000
3196	123-0471	G1807	63,5 mm	50,8 mm	18000K	24023	24024	Blindada Proprietary Blindata		19878, 19869		24001
3196	197-1328	G18071-01	63,5 mm	50,8 mm	18000K	24023	24024	Blindada Proprietary Blindata		23837, 19869		24001
3406C	201-0956	G18061-01	63,5 mm	63,5 mm	18000K	24004	24006	Blindada Proprietary Blindata		23837, 19869		24001
3406E	196-8895	G18081-01	95 mm	95 mm	18000K	24004	24007	Blindada Proprietary Blindata		23837, 23045		24002
<b>Chrysler Marine</b>												
318 & 360	4142878	G7	31,8 mm	31, mm	10615K	23976	23977	Obsoleta Obsoleto Obsoleto		12859	(2) 23448	
318 & 360	4142878	G7B	31,8 mm	31,8 mm	10615K	23976	23977	Bomba SHE SHE pump Pompa SHE		12859	(2) 23448	
M273X, LM318X	2847630	D60	25,4 mm	25,4 mm	(2)09959K	10656	12300	Bomba SHE SHE pump Pompa SHE		10927	4257	
M273X, LM318X	2847631	D65	25,4 mm	25,4 mm	(2) 09959K	10656	12300	Obsoleta Obsoleto Obsoleto	D60	10927	4257	
LM318-X, LM340-X	2846428	C-03			10615K	10999	11068	Obsoleta Obsoleto Obsoleto	G7B	1092	4257	
LM318-X, LM340-X	3675763	G5	31,8 mm	31,8 mm	10615K	23976	23977	Obsoleta Obsoleto Obsoleto	G7B	12859	(2) 23448	
LM318-X, LM340-X	3745511	G5-1	31,8 mm	31,8 mm	10615K	23976	23977	Obsoleta Obsoleto Obsoleto	G7B	12859	(2) 23448	
LM318-X, LM340-X	3619030	F10	31,8 mm	31,8 mm	10615K	10999	11068	Obsoleta Obsoleto Obsoleto	G50	10927	4257	
LM318-X, LM340-X	3619212	G50	31,8 mm	31,8 mm	10615K	23976	23977	Obsoleta Obsoleto Obsoleto		12859	(2) 23448	
<b>Crusader (Dearborn)</b>												
220, 270, 300, 350	97179	E35	25,4 NPT	25,4 NPT	10615K	10999	11068	Bomba SHE SHE pump Pompa SHE		10927	4257	
Interceptor		F15	19,1 NPT	19,1 NPT	09959K			Obsoleta Obsoleto Obsoleto	R50G	10927	4257	
220, 270, 300, 350		S11040G	25,4 NPT	25,4 NPT	10615K	10999	11068	Obsoleta Obsoleto Obsoleto	E35	10927	4257	
220, 270, 300, 350		B04	25,4 NPT	25,4 NPT	10615K	10999	11068	Obsoleta Obsoleto Obsoleto	E35	10927	4257	
220, 270, 300, 350	40050	P101	31,8 mm	31,8 mm	10615K	19301	19300	Blindada Proprietary Blindata		12859	(2) 23448	

# SHERWOOD

MOTOR ENGINE MOTORE	R.O. OEM	BOMBA PUMP POMPA	ENTRADA INNER ENTRATA	SALIDA OUTLET USCITA	IMPULSOR IMPELLER GIRANTE	KIT MENOR MINOR	KIT MAJOR MAJOR	DISPOSICIÓN AVAILABLE DISPONIBILE	BOMBA REEMPLAZADA REPLACED PUMP POMPA RIMPLAZATA	KIT RETÉN SEAL KIT KIT PARAOLIO	COJINETE BEARING CUSCINETTO	KIT EJE + COJINETE KIT SHAFT + BEARING KIT ASSE + CUSCINETTO
<b>Cummins</b>												
6B 250 HP / 4B CEPC	3920298	GC4	38,1mm	38,1 mm	15000K	23980	23981	Obsoleta Obsoleto Obsoleto	GC5	12859, 10514	(2) 23448	
6B 250 HP / 4B CEPC	3927684	GC5-01	38,1 mm	38,1 mm	15000K	23980	23981	Blindada Proprietary Blindada	GC5	12859, 10514	(2) 23448	
4B 250 HP	3349340	G1503-01	38,1 mm	38,1 mm	15000K	23980	23256	Blindada Proprietary Blindada	G1503	12859, 12966	(2) 23448	
6B	3919899	P1712	40 mm	40 mm	17000K	23972	23974	Obsoleta Obsoleto Obsoleto	P1716C	15955, 19674	(2) 15951	
6B	3922590	P1716B-01	50,8 mm	40 mm	17000K	23972	23974	Blindada Proprietary Blindada	P1716	15955, 19674	(2) 15951	
6C,6B 270-450 HP	3912139	P173	40 mm	40 mm	17000K	23972	23974	Obsoleta Obsoleto Obsoleto	P1722C	15955, 19674	(2) 15951	
6C	3922589	P1722B-01	50,8 mm	40 mm	17000K	23972	23974	Blindada Proprietary Blindada	P1722C	15955, 19674	(2) 15951	
6C,6B 270-450 HP	3897194	P1727FB-01	Codos con brida Flanged Elbows Gomiti con fascetta	Codos con brida Flanged Elbows Gomiti con fascetta	17000K	23972	23974	Blindada Proprietary Blindada	P1727C	15955, 19674	(2) 15951	
6C,6B 270-450 HP	3866493	P1730F-01	Codos con brida Flanged Elbows Gomiti con fascetta	Codos con brida Flanged Elbows Gomiti con fascetta	17000K	23972	23974	Blindada Proprietary Blindada	P1730C	15955, 19674	(2) 15951	
6C	4003526	P1731F-01	Codos con brida Flanged Elbows Gomiti con fascetta	Codos con brida Flanged Elbows Gomiti con fascetta	17000K	23972	23974	Blindada Proprietary Blindada	P1730C	15955, 19674	(2) 15951	
QSM11	3349392	G1810-01	Codos con brida Flanged Elbows Gomiti con fascetta	Codos con brida Flanged Elbows Gomiti con fascetta	18000K	24005	24008	Blindada Proprietary Blindada	G1810	23512, 19869		24003
<b>Kohler</b>												
Ford	344089	G907P-01	9,5 NPT	9,5 NPT	09000K			Bomba SHE SHE pump Pompa SHE	G907P	22546	(2) 23448	
4-6.5 KW Gas	344371	G907 -01	9,5 NPT	9,5 NPT	09000K			Bomba SHE SHE pump Pompa SHE	G907P	22546	(2) 23448	
5-7 KW Diesel	359341	GP8001	9,5 NPT	9,5 NPT	08000K			Bomba SHE SHE pump Pompa SHE		23459	(2) 23323	
<b>Mercuriser</b>												
7.3 Diesel	L/270	G151	38,1 mm	38,1 mm	15000K	23980	23981	Bomba SHE SHE pump Pompa SHE		12859	(2) 23448	
7.3 Diesel	L/270	G155	38,1 mm	38,1 mm	15000K	23980	23981	Bomba SHE SHE pump Pompa SHE		12859	(2) 23448	
<b>Onan</b>												
4 Cil Diesel	132-0275	K75	25,4 mm	25,4 mm	09959K	23979	12665	Obsoleta Obsoleto Obsoleto	K75B	12859	(2) 23448	
4 Cil Diesel	132-0276	K75B	25,4 mm	25,4 mm	09959K	23979	12665	Bomba SHE SHE pump Pompa SHE		12859	(2) 23448	
5 Cil Diesel	132-0278	L10	31,8 mm	31,8 mm	10615K	23976	23977	Obsoleta Obsoleto Obsoleto	L10B	12859	(2) 23448	
5 Cil Diesel	132-0278	L10B	31,8 mm	31,8 mm	10615K	23976	23977	Bomba SHE SHE pump Pompa SHE		12859	(2) 23448	
5 Cil Diesel	132-0343	G1004	25,4 mm	25,4 mm	10615K	10615K	22014	Obsoleta Obsoleto Obsoleto	G1006	21208, 21209	(2) 23448	
5 Cil Diesel	132-0347	G1005	25,4 mm	25,4 mm	10615K	10615K	22014	Obsoleta Obsoleto Obsoleto	G1006	21208, 21209	(2) 23448	
<b>OMC</b>												
In Board	981939	G45-2	31,8 mm	31,8 mm	10615K	23976	23977	Obsoleta Obsoleto Obsoleto	G46	12859	(2) 23448	
V8 Chevy	985096	G46	31,8 mm	31,8 mm	10615K	23976	23977	Obsoleta Obsoleto Obsoleto		12859	(2) 23448	
6-8 Cil	3852398	G9901	31,8 mm	25,4 mm	09959K	23979	12665	Bomba SHE SHE pump Pompa SHE		12859	(2) 23448	
4 Cil	3852399	G9902	31,8 mm	25,4 mm	09959K	23979	12665	Obsoleta Obsoleto Obsoleto	G9903	12859	(2) 23448	
4 Cil	3855079	G9903	31,8 mm	25,4 mm	09959K	23979	12665	Bomba SHE SHE pump Pompa SHE		12859	(2) 23448	

**SHERWOOD**

MOTOR ENGINE MOTORE	R.O. OEM	BOMBA PUMP POMPA	ENTRADA INNER ENTRATA	SALIDA OUTLET USCITA	IMPULSOR IMPELLER GIRANTE	KIT MENOR MINOR	KIT MAYOR MAJOR MAGGIORE	DISPOSICIÓN AVAILABLE DISPONIBILE	BOMBA REEMPLAZADA REPLACED PUMP POMPA RIMPLAZZATA	KIT RETÉN SEAL KIT KIT PARAOLIO	COJINETE BEARING CUSCINETTO	KIT EJE + COJINETE KIT SHAFT + BEARING KIT ASSE + CUSCINETTO
<b>Perkins Engine U.S.</b>												
40-108 Diesel	NA003335	G65	19,1 NPT	19,1 NPT	09959K	09959K	12221	Bomba SHE SHE pump Pompa SHE		10514	(2) 23448	
4-154 Diesel	NA005576	H5	25,4 mm	25,4 mm	09959K	12981	12980	Bomba SHE SHE pump Pompa SHE		10514, 06602	(2) 4257	
6-354 Diesel	NA001175	RPBC	25,4 NPT	25,4 NPT	10615K	10999	11068	Bomba SHE SHE pump Pompa SHE		10927	4257	
<b>Pleasurecraft Marine</b>												
Chevy 454		G55-2	31,8 mm	31,8 mm	10615K	23976	23977	Bomba SHE SHE pump Pompa SHE		12859	(2) 23448	
302 - 351		G20	25,4 mm	25,4 mm	09959K	23979	12665	Obsoleta Obsolete Obsoleto	G21	12859	(2) 23448	
302 - 351		G21-01	25,4 mm	25,4 mm	09959K	23979	12665	Blindada Proprietary Blindata	G21	12859	(2) 23448	
Mitsubishi 4 Cil		G22-01	-	-	09959K	23979	12665	Blindada Proprietary Blindata	G22	12859	(2) 23448	
7.3L Diesel		G26-01	31,8 mm	31,8 mm	10615K	23976	23977	Blindada Proprietary Blindata	G26	12859	(2) 23448	
350 GM		P105-01	31,8 mm	31,8 mm	10615K	10615K	19354	Blindada Proprietary Blindata	P105	18652	(2) 08490	
5.7L V8 GM		P1012-01	31,8 mm	31,8 mm	10615K	19301	19300	Blindada Proprietary Blindata		12859	(2) 23448	
8.1L V8 GM		P109	31,8 mm	31,8 mm	10615K	10615K	19354	Blindada Proprietary Blindata		18652	(2) 08490	
<b>Volvo Penta</b>												
		G30-2	25,4 mm	25,4 mm	09959K	23979	12665	Bomba SHE SHE pump Pompa SHE		12859	(2) 23448	
		G85	31,8 mm	31,8 mm	10615K	23976	23977	Bomba SHE SHE pump Pompa SHE		12859	(2) 23448	
6-8 Cil	3852398	G9901	31,8 mm	25,4 mm	09959K	23979	12665	Bomba SHE SHE pump Pompa SHE		12859	(2) 23448	
4 Cil	3852399	G9902	31,8 mm	25,4 mm	09959K	23979	12665	Obsoleta Obsolete Obsoleto	G9903	12859	(2) 23448	
4 Cil	3855079	G9903	31,8 mm	25,4 mm	09959K	23979	12665	Bomba SHE SHE pump Pompa SHE		12859	(2) 23448	
<b>J.H.Westerbeke Corp.</b>												
Pilot 10-20	16423	F85-01	12,7 NPT	12,7 NPT	09959K		12221	Blindada Proprietary Blindata		10514	(2) 23448	
Gov Life Boat	11353	R10870G-01	19,1 NPT	19,1 NPT	09959K	10997	12937	Bomba SHE SHE pump Pompa SHE	R10870G	10927	4257	
Gov Life Boat	302648	G903	12,7 NPT	12,7 NPT	09000K			Obsoleta Obsolete Obsoleto	G908-01	12859, 18806	(2) 23448	
Gov Life Boat	42175	G908-01	12,7 NPT	12,7 NPT	09000K			Blindada Proprietary Blindata		12859, 18806	(2) 23448	

GUÍA DE KITS  
KITS GUIDE  
GUIDA KIT

REF KIT	BOMBA DE AGUA WATER PUMP POMPA ACQUA	CASQUILLO BUSHING BOCCOLA	COJINETE BOLAS BALL BEARING CUSCINETTO A SFERE	SELLO SEAL ASSY SIGILLANTE	ARO TÓRICO O-RING O-RING	IMPULSOR IMPELLER GIRANTE	LEVA CAM CAMMA	PLACA PLATE PIASTRA	CHAVETA KEY CHIAVETA	TAPA COVER COPERCHIO	RETÉN LIP SEAL PARAOILIO	AROS RETENCIÓN RETAINING RINGS ANELLO	ARANDELA WASHER RONDELLA	EJE SHAFT ASSE
SHE09959K	R991, B06, G65				2	1								
SHE10615K	P102, P105, P109, G1004, G1005, G1006, G1008				2	1								
SHE10656	D75, D60, D65			1	2	2								
SHE10996	R30G-1, E05, R30G			1	2	1			1			1		
SHE10997	R10870G, R10930G, R50G			1	2	1			1			1		
SHE10999	E35, C-03, F10, S11040G, B04, R10970G, RPBC, F95, R102			1	1	1			1			1		
SHE19301	P101, P1012			1	1	1								
SHE23972	P1712, P1716B, P173, P1722B, P1727FB, P1730F, P1731F, P1711, P1719, P1719F			1	1	1		1	1			1		
SHE23973	P171, P176, P172, P1710, P1726, P1726TC, P1732			1	1	1		1	1			1		
SHE23976	G3, G4, G5, G5-1, G7, G7B, G8, G26, G45-1, G45-2, G46, G50, G55-2, G56, G85, H-85, K90, L10, L10B, L80, L90, M71			1	2	1			1			3	1	
SHE23979	G1, G2, G15, G20, G21, G22, G30-2, G30-2B, G95-1, G9901, G9902, G9903, H10, J70, K75, K75B			1	2	1			1			3	1	
SHE23980	GC1, GC4, GC5, G157, G151, G155, G1503			1	2	1			1			3	1	
SHE24004	G1804, G1806, G18061, G1808, G18081			1	2	1	2					1	1	
SHE24005	G1810			1	2	1	2					1	1	
SHE24023	G1805, G1807, G18071			1	2	1	2					1	1	
SHE11068	E35, C-03, F10, S11040G, B04, RPBC, R102	1	1	1	1	1	1		1			3		
SHE12221	G65, F85		2		1	1					1			
SHE12300	D60, D65	1	1	1	2	2	2	1						
SHE12665	G1, G2, G15, G20, G21, G22, G30-2, G30-2B, G95-1, G9901, G9902, G9903, H10, J70, K75, K75B		2	1	2	1	1	1	1			5	1	
SHE12937	R10870G, R50G	1	1	1	2	1	1		1			4		
SHE12980	H5		1		1	1	1		1		1			
SHE19300	P101, P1012		2	1	1	1						1		
SHE19354	P102, P105, P109		2		2	1					1	1		1
SHE23256	G1503		2	2	1	1		1	1	1		3	1	
SHE23974	P1712, P1716B, P173, P1722B, P1727FB, P1730F, P1731F, P1711, P1719, P1719F		2	1	1	1	1	1	1	1	1	3	3	
SHE23975	P171, P176, P172, P1710, P1726, P1726TC, P1732		2	1	1	1	1	1	1	1	1	3	3	
SHE23977	G3, G4, G5, G5-1, G7, G7B, G8, G26, G45-1, G45-2, G46, G50, G55-2, G56, G85, H-85, K90, L10, L10B, L80, L90, M71		2	1	2	1	1	1	1			5	1	
SHE23981	GC1, GC4, GC5, G157, G151, G155		2	1	2	1	1	1	1			5	1	
SHE24006	G1804, G1806, G18061			1	2	1	2	1		1	1	2	2	
SHE24008	G1810			1	2	1	2	1		1	1	2	1	
SHE24024	G1805, G1807, G18071			1	2	1	2	1		1	1	2	2	



# IMPULSORES IMPELLER GIRANTE

## SUGERENCIAS TÉCNICAS TECH TIPS SUGGERIMENTI TECNICI

**SHERWOOD da tres sugerencias sencillas para instalar un impulsor nuevo:**

- 1 Use un lubricante con base NO derivada del petróleo (por ejemplo, silicona o agua jabonosa) para instalar el impulsor de una forma más sencilla.
- 2 Instale el impulsor en el eje con un movimiento rotatorio. Nunca fuerce el impulsor sobre el eje. Debe moverse libremente sobre el eje para un cebado y funcionamiento adecuados.
- 3 Aplique una pequeña cantidad de lubricante con base NO derivada del petróleo para fijar el aro tórico en su sitio y coloque la tapa.

SHERWOOD recomienda inspeccionar detenidamente el impulsor al realizar el mantenimiento de la bomba. Reemplace el impulsor si observa lo siguiente: desgarro o rotura en alguna de las palas del impulsor. Flexione las palas para poder examinarlas mejor.

**EL RECALENTAMIENTO ES LA CAUSA PRINCIPAL DEL DESGASTE PREMATURO DEL MOTOR. PARA MANTENER EL BUEN RENDIMIENTO DEL MOTOR, NO DUDE EN ADQUIRIR LOS IMPULSORES SHERWOOD ORIGINALES.**

**Sherwood suggests three easy tips to help you install your new impeller:**

- 1 Use a Non-petroleum based lubricant (i.e. silicone or soapy water) to help slide the impeller.
- 2 Install the impeller with a twisting motion onto the shaft. Never force the impeller onto the shaft. The impeller must move freely on the shaft to properly prime and function.
- 3 Use a small amount of Non-petroleum based lubricant to help hold the o-ring when replacing the cover.

SHERWOOD recommends inspecting your impeller closely during any pump maintenance. Replace the impeller if you discover either of the following: tear or rip on any of the impeller blades. Flex the blades to examine more thoroughly.

**THE 1 REASON FOR PREMATURE ENGINE WEAR IS OVERHEATING. TO MAINTAIN ENGINE PERFORMANCE, INSIST UPON GENUINE SHERWOOD IMPELLERS**

**SHERWOOD consiglia tre semplici accorgimenti per l'installazione di una girante nuova:**

- 1 Utilizzare un lubrificante con una base che Non derivi dal petrolio (per esempio silicone, o acqua insaponata).
- 2 Montare la girante con un movimento rotatorio, tenendo conto che essa deve muoversi liberamente per un corretto funzionamento. Non spingere mai la girante sopra l'asse.
- 3 Applicare una piccola quantità di lubrificante, posizionare l'anello di tenuta nella posizione corretta, quindi, procedere a montare il coperchio.

SHERWOOD raccomanda ispezionare attentamente la girante, e si osserva il seguente: strappatura o rottura di una o più pale, provvedere a sostituirla.

**IL RISCALDAMENTO È LA CAUSA PRINCIPALE DEL CONSUMO DEL MOTORE. PER MANTENERE UN BUON RENDIMENTO DEL MOTORE NON DUBITARE AD ACQUISTARE LE GIRANTI SHERWOOD ORIGINALI**

## EXTRACTOR DE IMPULSORES IMPELLER EXTRATOR ESTRATTORE GIRANTI

Ref.	IMPULSORES IMPELLERS GIRANTI
SHE25105	17000
	18000
	22000
	26000
SHE25106	27000

SHE25106



SHE25105

## IMPULSORES DE NEOPRENO NEOPRENE IMPELLERS GIRANTI IN NEOPRENE

REF	B (mm)	C (mm)	A (mm)	EJE SHAFT ASSE	PALAS BLADES PALE	ESTRÍAS SPLINED DENTI	
SHE08000K	40.0	19	11.1	-	6		
SHE10187	66.0	50	15.9	5/8"	9		
SHE10077K	57.0	20	12.7	3/32"	12		
SHE09000K	62.5	22	15.9	3/16"	12		
SHE09959K	62.5	32	15.9	3/16"	12		
SHE10615K	65.0	41	15.9	3/16"	12		
SHE15000K	65.0	51	15.9	3/16"	12		
SHE17000K	84.0	73	20.0	3/16"	12		
SHE27000K	84.0	73		Estr.splined	12	11	
SHE18000K	95.0	102	23.8	Estr.splined	12	14	30°
SHE26000K	95.0	80			12	10	45°
SHE29000K	95.0	102	23.8	Estr.splined	12	10	45°
SHE30000K	114.0	110	25		10	10	45°
SHE22000K	114.0	110	25		10	14	30°

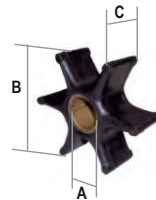



SHE08000K



SHE10187



SHE10077K



SHE09959K

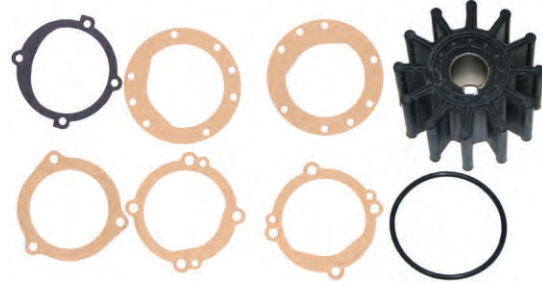

SHE10615K



SHE15000K



SHE17000K



SHE18000K



SHE27000K



SHE26000K



SHE22000K



SHE29000K



SHE30000K



SHE09000K

# IMPULSORES IMPELLER GIRANTE

TIPOS DE CASQUILLO  
BUSH TYPE  
TIPO DI ACCOPIAMENTO

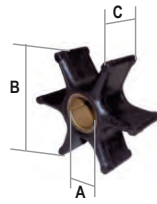
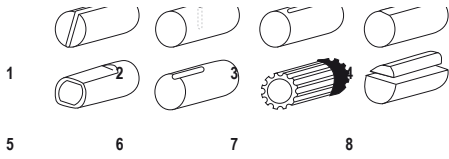

JAB11979-0001



JAB17018-0001



JAB17370-0001



JAB17937-0001-P



JAB5616-0001



JAB3085-0001

REF	R.O. OEM	PALAS BLADES PALE	TIPO CASQUILLO BUSHING TYPE TIPO BOCCOLA	MEDIDAS (mm) MEASURES (mm) MISURE (mm)		
				A	B	C
JAB11979-0001	CHRYSLER	8	7	16	65	36,65
JAB12104-0001	YANMAR 128170-42070	6	2	8	32	12
JAB14750-0001		8	4	8	32	12
JAB14750-0003		8	4	8	32	12
JAB17018-0001	MERCURISER DIESEL VOLVO 3583602 CATERPILLAR 3N5895	8	7	16	65	76,20
JAB17370-0001	DDA 8927570 CUMMINS 3008503 CATERPILLAR 3N-4859	12	5	25	95	88,90
JAB17937-0001-P	VOLVO 801277, 825941, 877061-2 CATERPILLAR 7C-3286 YANMAR 127610-42200 PERKINS 0460024, 24880031	10	7	16	65	51
JAB17938-0001-P	VOLVO 3830663	12	7	25	95	95
JAB17956-0001		10	6	16	65	51
JAB18777-0001-P		10	7	16	57	51
JAB18786-0001		9	5	25	118	88,90
JAB18789-0001		9	7	25	118	88,90
JAB3085-0001	CHRIST-CRAFT FORD 18830-1020, 18840-1010 PERKINS USA 24880190	10	7	16	57	31,50
JAB30919-0001		12	5	20	77	76,20
JAB4527-0001		6	2	8	51	22
JAB5616-0001	WESTERBEKE 5320-0011	6	6	12,7	51	22



JAB12104-0001



JAB14750-0001



JAB14750-0003



JAB17938-0001-P

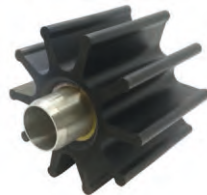

JAB17956-0001

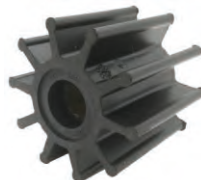

JAB18777-0001-P



JAB18786-0001



JAB18789-0001



JAB30919-0001



JAB4527-0001

# GUÍA DE IMPULSORES IMPELLERS GUIDE GUIDA GIRANTI

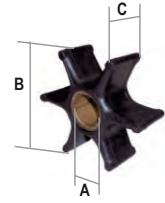

## PIN DRIVE

PALAS BLADES PALE	MEDIDAS (mm) MEASURES (mm) MISURE (mm)			RECMAR	CEF	JOHNSON	SHERWOOD	JABSCO	VOLVO	MERCURIS- ER	YANMAR	VETUS	PERKINS	SOLE DIESEL	MANNI DIESEL	ONAN	WESTER- BEKE
	A	B	C														
	6	9,54	39,6														
6	9,54	39,6	18,94	REC3586494	CEF500200GX	JOH09-806B	9979	4528-0001-P	3586494		104211-42071	IMP00501	24880272			132-0859	
6	10	39,6	19,2		CEF500131X									321.11.008			
6	12	39,6	19,2	REC3586496	CEF500121GX	JOH09-808B		22405-0001	3586496			IMP00601			434013	132-0310	32620
6	12	52	25		CF500123X									312.11.008			
6	12,17	50,8	22,1	REC653-0001	CEF500101X	JOH09-810B		653-0001			128990-42200	STM8061			434014		33636
6	12,17	50,8	22,1	REC653-0001	CEF500201	JOH09-810B		653-0001			128990-42200	STM8061			434014		
6	12,66	50,8	22,1	REC3593659	CEF500116GX	JOH09-1026B		673-0001	3593659	47-810567		IMP00901	24880194				34440
6	12,66	50,8	22,1	REC3593659	CEF500216	JOH09-1026B		673-0001	3593659	47-810567		IMP00901	24880194				34440
10	12,17	51,8	22		CEF500146X			18653-0001-P				IMP00701					
10	12,66	51,8	22		CEF500156GX			18673-0001									



## SPLINE

PALAS BLADES PALE	MEDIDAS (mm) MEASURES (mm) MISURE (mm)			RECMAR	CEF	JOHNSON	SHERWOOD	JABSCO	VOLVO	MERCURIS- ER	YANMAR	PLEASURE- CRAFT	CATERPILLAR	CUMMINS	MAN	DETROIT	VETUS	PERKINS	SOLE D	YAMAHA	RENAULT	ONAN	WESTERBEKE	
	A	B	C																					
	8	14,29	58,65																					36,65
8	14,29	65	50,2	REC3841697	CEF500106GT	JOH09-1028B		920-0001	3841697	47-801332602	127610-42200	R061003E	3N1906	650607	50.06506.0091	5193602		460024	347-11-008		RC320D			
8	14,29	65	50,2	REC3841697	CEF500206	JOH09-1028B		920-0001			127610-42200	R061003E	3N1906	650607		5199148		24880031						
8	14,29	65,2	76,65	REC3593573	CEF500177GT			JAB17018-0001	3593573	47-816814T				3N5895										
9	22,5	95	88,5	REC6760-0001	CEF500115T	JOH09-802B		6760-0001																
9	22,5	96	63,1	REC836-0001	CEF500105T	JOH09-1029B		836-0001	21730344			1L4774	556540			5193553	IMP00901	460027						
9	22,5	96	63,1	REC836-0001	CEF500205	JOH09-1029B		836-0001	875736			1L4774	556850			5193553	IMP00901	460027						
9	22,5	117,6	88,5	REC18789-0001	CEF500144			JAB18789-0001																
10	14,29	65	50,1	REC17937-0001	CEF500114T		18200	JAB17937-0001-P	3588475	47-8013326-01							IMP00301							
10	14,29	65	50,1	REC17937-0001	CEF500214		18200	JAB17937-0001-P		47-8013326-01							IMP00301							
10	14,29	65	68,2	REC47-809866T	CEF500161			31130-0061		47-831311350	119593-42202													
10					CEF500172			DEV4307																
12	14,29	57	31,6	REC21213660	CEF500207	JOH09-1027B		1210-0001	21213660		129470-42532	R061003				5194205	IMP00201	460038	351-11-008		131-0050	302571		
12	14,29	57	48,2	REC13554-0001	CEF500124	JOH09-812B		13554-0001			119773-42600									GTA-12457-00				
12	12,29	57	48,2	REC21213664	CEF500178G				21213664															
12	14,29	57	50,2	REC22120-0001	CEF500104			JAB18777-0001-P	876120															
12	14,29	57,15	48,25		CEF500150			13554-6001																
12	22,5	65,8	80	REC3887761	CEF500162G	JOH09-821B			3887761		119574-42552			51.06506.0103										
12	22,5	95	63,1		CEF500135	JOH09-819B		17935-0001	21951362				5N9360			8924838		7054						
12	22,5	95	88,5	REC875697	CEF500145T	JOH09-814B		17936-0001	21951364		165000-35270		4L8470		50.06506.0089	5196168	IMP00801	460027						
12	22,5	95	95		CEF500163G			JAB17938-0001-P	3830459															
12	22,5	96,5	130	REC09-820B	CEF500186T	JOH09-820B									51.06506.0106									
12						JOH09-842B									51.06506.0127									



## KEY DRIVE

PALAS BLADES PALE	MEDIDAS (mm) MEASURES (mm) MISURE (mm)			RECMAR	CEF	JOHNSON	SHERWOOD	JABSCO	VOLVO	MERCURIS- ER	OMC	CRUSADER	CHRIS-CRAFT	PLEASURE- CRAFT	YANMAR	CATERPILLAR	CUMMINS	VETUS	PERKINS	YAMAHA	RENAULT	ONAN	WESTERBEKE	KOHLER	
	A	B	C																						
	6	10	50,8																						22,1
6	12,75	50,8	22,1	REC22779-0001	CEF500129	09-827		22779-0001							128620-42201			IMP00101				48300055		229955	
8	15,9	65	50,2	REC4598-0001	CEF500102T		10187	4598-0001	818680																
8	15,9	65	50,2	REC4598-0001	CEF500202		10187	4598-0001	818680																
8	15,93	65,2	50,2		CEF500160			4599-0101																	
8	15,95	62,2	22,4	REC09000K	CEF500165		SHE09000K								128620-42200								302875	229826	
8	17	65	48,6		CEF500122T																		48300008		
8	17	66	32		CEF500128																		48300007		
12	12,8	56,6	19,8		CEF500166		SHE10077K					16.80-90047											132-0375	33112	
12	15,9	62	31,7	REC3854286	CEF500103T	09-701	SHE09959K	18838-0001	3854286		3854286	1003026		R061015					NA900010	10103-100C			132-0317	33104	
12	15,9	65,2	41,3	REC10615K	CEF500120T	09-702	SHE10615K	18948-0001	835874		981939	20300		16.80-90131	R061017		3908220		NA900012	6TA-12457-00			132-0349	33779	
12	15,93	57	31,6		CEF500208			4568-0003																	
12	16	57	31,6	REC875575	CEF500170CG	JOH09-801B		6174-0001	875575						145410-46090										
12	16	65	51,2	REC15000K	CEF500167		SHE15000K	18327-0001		47-853126															
12	20,1	84	73,5	REC17000K	CEF500164T	09-704	SHE17000K	18958-0001							1W5664	3802444									



**SINGLE FLAT DRIVE**

PALAS BLADES PALE	MEDIDAS (mm) MEASURES (mm) MISURE (mm)			RECMAR	CEF	JOHNSON	SHERWOOD	JABSCO	MERCURISER	YANMAR	ONAN	KOHLER
	A	B	C									
	6	7,31	50,8									
6	7,31	50,8	22,1		CEF500210	09-824		6303-0003				
6	7,31	51,3	22		CEF500138	09-834		6303-0001				
6	7,31	51,3	22		CEF500238	09-834		6303-0001				
6	7,4	35,4	12,8		CEF500284G	09-1077						
6	8	44,6	13		CEF500132	09-1052B-9						
6	8	44,9	13		CEF500232	09-1052-S9						
6	8	31,3	11,9		CEF500113			21411-0001		128176-42071		
6	8	31,3	11,9		CEF500213			14787-0003				
6	8	31,75	12		CEF500230			1414-0003				
6	12,2	19	40	REC08000K	CEF500190G		SHE08000K				132-0415	359978
6	22,3	60	33,8	REC47-89984T4	CEF500313G				47-89984T4			
6	22,4	89	32,5	REC47-43026Q02	CEF500301				47-43026Q02			
8	16,85	66,5	50,6	REC47-59362Q01	CEF500109			17954-0001-P	47-59362Q01			
10	16,85	65	50,7		CEF500148			17954-0001				



**KEY DRIVE**

PALAS BLADES PALE	MEDIDAS (mm) MEASURES (mm) MISURE (mm)			RECMAR	CEF	JOHNSON	SHERWOOD	JABSCO	VOLVO
	A	B	C						
	12	10	39,6						



**SPECIFIC DRIVE**

PALAS BLADES PALE	MEDIDAS (mm) MEASURES (mm) MISURE (mm)			RECMAR	CEF	JOHNSON	SHERWOOD	JABSCO	OMC
	A	B	C						
	10	12,76	85,5						

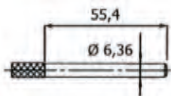

PALAS BLADES PALE	MEDIDAS (mm) MEASURES (mm) MISURE (mm)			RECMAR	CEF	JOHNSON	SHERWOOD	JABSCO
	A	B	C					
	6	39,1	18,9					



**DOUBLE FLAT DRIVE**

PALAS BLADES PALE	MEDIDAS (mm) MEASURES (mm) MISURE (mm)			RECMAR	CEF	JOHNSON	SHERWOOD	JABSCO	MERCURISER	CATERPILLAR	CUMMINS	DETROIT
	A	B	C									
	8	11,4	66,5									
9	20,2	117,6	88,5	REC18786-0001	CEF500153			JAB18786-0001		PP1027		23502086
10	13,42	57,18	50,25		CEF500157			50461-1001				
11	25,4	94	63		CEF500185	09-0838S						
12	20,2	95	88,5	REC17370-0001	CEF500152			JAB17370-0001		3N8459	3008503	8927570



**PULLER DRIVE**

PALAS BLADES PALE	MEDIDAS (mm) MEASURES (mm) MISURE (mm)			RECMAR	CEF	JOHNSON	SHERWOOD	JABSCO	YANMAR	CATERPILLAR	CUMMINS
	A	B	C								
	10	20,7	114,3								
10	24,35	114,3	109,5		CEF500193GX		SHE30000K				
12	16,1	84	73	REC27000K	CEF500181G		SHE27000K				3974456
12	20	94,5	79,8		CEF500183G		SHE26000K				3972366
12	20	94,5	101,5	REC29000K	CEF500192GX		SHE29000K		128620-42201	2968388	
12	20,7	94,5	101,5	REC18000K	CEF500182G		SHE18000K			1095327	4019403

# FILTRACIÓN FILTRATION FILTRAZIONE

## FILTROS PARA MONTAJE EN LÍNEA IN-LINE FILTER FILTRI PER MONTARE IN LÍNEA



Ref.			
GS31185	6-8 mm	1	
GS31186	6-8 mm	1	Cubeta extraíble Removable bowl Vasca estraibile



GS31185



GS31186

Ref.	MOTORES ENGINES MOTORI
REC35-80365M	2 - 8 HP (2 Strokes) 8 - 15 HP (4 Strokes)



Ref.	MOTORES ENGINES MOTORI
PAF4-05000300	4 - 9.8 HP (2 Strokes) 4 - 25 HP (4 Strokes)



Ref.	
REC40145	1/4"
REC40155	5/16"
REC40165	3/8"
REC40135	5/16" Entrada / In / Entrata 3/8" Salida / Out / Uscita



Ref.		
GS30435	6, 8, 10 mm	1

De metal y cristal. Montaje en línea.  
Racors para mangueras de 6-8-10 mm.  
In-line. Clear body permits visual inspection.  
Racors 6-8-10 mm.  
Di metallo e cristallo. Montare in línea.  
Raccordi per tubi da 6-8-10 mm.



Ref.			
GS31001	50 l/h	6 - 8 mm	1
GS31002	150 l/h	8 - 10 mm	1



Filtro transparente para gasolina o gasoil.  
Transparent plastic in line filter for petrol and diesel.  
Filtro trasparente per benzina o gasolio.



GS31001

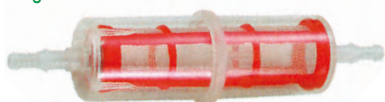

GS31002

## FILTRO SEPARADOR DE AGUA WATER SEPARATING FUEL FILTER FILTRO SEPARATORE ACQUA-BENZINA

Ref.	MICRAS MICRON MICRON	
REC24942	10	4-7/16"
REC35-802893Q01	10	4-7/16"
REC855686	28	4-7/16"
REC35-802893Q	25	3-3/4"
RACPF5510	10	4-7/16"



RACPF5510



REC24942 REC35-802893Q01 REC855686 REC35-802893Q

Ref.	MICRAS MICRON MICRON	
RM35-802893Q	10	3-3/4"

Filtro original.  
OEM filter.  
Filtro benzina originale.



Ref.		MICRAS MICRON MICRON
REC24950	50 l/h 1/4"	25
REC24952	50 l/h 1/4"	10

FILTRO CON BRACKET  
Bracket de Aluminio. Con 2 tapones de bronce y 1 tubo de extensión.  
OEM FILTER WITH BRACKET  
Cast Aluminium Bracket. With 2 brass plugs & 1 extension tube.  
FILTRO BENZINA CON SUPPORTO  
Supporto in alluminio. Con 2 tappi di bronzo e 1 tubo di estensione.



## FILTRO DECANTADOR COMPLETO COMPLETE FUEL FILTERS FILTRI DECANTATORE COMPLETO

FILTRO COMPLETO COMPLET FILTER FILTRO COMPLETO	CARTUCHO RECAMBIO REPLACEMENT ELEMENT CARTUCCIA DI RICAMBIO	MOTORES ENGINES MOTORI
REC23299-10	RAC23289-10	130 HP (4 STROKES)



**FILTROS / FILTERS / FILTRI**

**FILTROS DECANTADORES  
COMPLETE FUEL FILTERS  
FILTRI DECANTATORE**



	RAC120R-RAC-01	RAC320R-RAC-01	RAC320R-RAC-03 RAC320R-INOX-01	RAC320R-RAC-02 RAC320R-INOX-02	RAC490R-RAC-01
FLUJO MÁXIMO MAX. FLOW FLUSSO MASSIMO	114 l/h 30 gph	340 l/h 60 gph	340 l/h 60 gph	340 l/h 60 gph	341 l/h 60 gph
ELEMENTO / ELEMENT / ELEMENTO	RACS3240	RACS3213	RACS3213	RACS3220UL	RACS3227 RACS3228UL
CAZOLETA TRANSPARENTE (sólo para fueraborda.) CLEAR BOWL (Just for outboards) VASCHETTA TRASPARENTE (Solo nei fuoribordo.)	✓	✓	✓	✗	✓
ROSCAS CENTRALES CENTRAL THREADS FILETTO CENTRALE	M18 x 1.5	1 1/4"	1 1/4"	1 1/4"	1 1/4"
TAMAÑO ROSCA CABEZA HEAD PORT SIZE DIMENSIONE VITE TESTA	1/4-18 NPTF	1/4-18 NPTF	1/4-18 NPTF	1/4-18 NPTF	1/4-18 NPTF
ALTURA X ANCHO X PROF. HEIGHT X WIDTH X DEPTH ALTEZZA X LARGH X PROF.	16 x 81 x 81 mm	238 x 102 x 102 mm	238 x 102 x 102 mm	238 x 102 x 102 mm	251 x 114 x 122 mm
PESO / WEIGHT / PESO	0,5 kg	0,9 kg	0,9 kg	0,9 kg	1,2 kg
CAIDA DE PRESIÓN PRESSURE DROP CADUTA DI PRESSIONE	0.15 PSI 0.01 bar	0.61 PSI 0.04 bar	0.61 PSI 0.04 bar	0.61 PSI 0.04 bar	101 PSI 0.07 bar
PRESIÓN MÁXIMA MAX. PRESSURE PRESSIONE MASSIMA	7 PSI 0.05 bar	7 PSI 0.05 bar	7 PSI 0.05 bar	7 PSI 0.05 bar	7 PSI 0.05 bar
DESMONTAJE CARTUCHO-CAZOLETA ELEMENT REMOVAL UNDERBOWL RIMOZIONE DELLA CARTUCCIA	25,4 mm 1"	25,4 mm 1"	25,4 mm 1"	25,4 mm 1"	25,4 mm 1"
TEMPERATURA DE TRABAJO OPERATING TEMPERATURE TEMPERATURA DI LAVORO			-40°C ± 24°C -40°F ± 55°F		

**ELEMENTOS DE RECAMBIO  
ELEMENT  
ELEMENTI DI RICAMBIO**

Ref.	MICRAS MICRON	FILTRO FILTER FILTRO
RACS3240 LENS3240	10	RAC120R-RAC-01
RACS3227 LENS3227	10	
RACS3213 LENS3213	10	RAC320R-RAC-01 RAC320R-RAC-01 INOX
RACS3214		
RACS3228UL		RAC320R-RAC-02, con/with/con bracket RACOR
RACS3220UL LENS3232		RAC320R-RAC-02



LENS3240  
LENS3227  
LENS3213



RACS3240  
RACS3227  
RACS3214



RACS3228UL  
RACS3220UL

**RÁCORES DE LATÓN  
BRASS RACORS  
RACCORDO IN OTTONE**

Ref.	ROSCA THREAD PASSO	MANGUERA HOSE TUBO	
GS31065	1/4" NPT	3/8" = 9.5 mm	2
GS31166	1/4" NPT	5/16" = 7.9 mm	2
GS31155	3/8" NPT	3/8" = 9.5 mm	2
GS31156	3/8" NPT	5/16" = 7.9 mm	2
GS31157	3/8" NPT	1/4" = 6.4 mm	2



Ref.	ROSCA THREAD PASSO	MANGUERA HOSE TUBO	
GS31066	1/4" NPT	5/16" = 7.9 mm	2
GS31067	1/4" NPT	3/8" = 9.5 mm	2



# FILTROS / FILTERS / FILTRI

## PRE-FILTRO PRE-FILTER PRE-FILTRO



FILTRO COMPLETO  
COMPLET FILTER  
FILTRO COMPLETO

REC1140639

CARTUCHO RECAMBIO  
REPLACEMENT ELEMENT  
CARTUCCIA DI RICAMBIO

REC3581078

FLUJO  
FLOW  
FLUSSO

50 l/h



FILTRO  
FILTER  
FILTRO

REC120

CARTUCHO RECAMBIO  
REPLACEMENT ELEMENT  
CARTUCCIA DI RICAMBIO

RACR12

FLUJO  
FLOW  
FLUSSO

15 gph



NEW

Filtro para gasolina o gasoil.  
Filter for petrol and diesel.  
Filtro per benzina o gasolio.



## FILTROS CON CAZOLETA Y ELEMENTOS BOWL FILTERS & ELEMENTS FILTRI CON VASCHETTA E ELEMENTI



	RAC500MA30	RAC900MA30	RAC1000MA30	RAC75/500MAX	RAC75/1000MA30
FLUJO MÁXIMO MAX. FLOW FLUSSO MASSIMO	227 l/h 60 gph	341 l/h 90 gph	681 l/h 180 gph	454 l/h 120 gph	681 / 1363 l/h 180 / 360 gph
ELEMENTO ELEMENT ELEMENTO	2010	2040	2020	2010	2020
ALTURA X ANCHO X PROF. HEIGHT X WIDTH X DEPTH ALTEZZA X LARGH X PROF.	292 x 147 x 122 mm	432 x 152 x 178 mm	559 x 152 x 178 mm	292 x 368 x 241 mm	559 x 476 x 279 mm
TAMAÑO ROSCA CABEZA HEAD PORT SIZE DIMENSIONE VITE TESTA	1/4-18 NPTF	1/4-18 NPTF	1/4-18 NPTF	1/4-18 NPTF	
PESO WEIGHT PESO	2 kg	3 kg	5 kg	7,7 kg	13,6 kg
CAIDA DE PRESIÓN PRESSURE DROP CADUTA DI PRESSIONE	0.61 PSI 0.04 bar	0.34 PSI 0.02 bar	0.49 PSI 0.03 bar	0.70 PSI 0.05 bar	3.70 PSI 0.25 bar
PRESIÓN MÁXIMA MAX. PRESSURE PRESSIONE MASSIMA	15 PSI 1 bar	15 PSI 1 bar	15 PSI 1 bar	15 PSI 1 bar	15 PSI 1 bar
ALTURA CLEARN. ALTEZZA	102 mm	127 mm	254 mm	102 mm	254 mm

## ELEMENTOS DE RECAMBIO ELEMENT ELEMENTI DI RICAMBIO

REF	R.O. OEM	REF	R.O. OEM	REF	R.O. OEM	MICRAS MICRON
RAC2010SM-OR	1147147	RAC2040SM-OR	889421	RAC2020SM-OR	889425	2
RAC2010TM-OR	861014	RAC2040TM-OR	3838852	RAC2020TM-OR	3838854	10
RAC2010PM-OR	3581760	RAC2040PM-OR	889419	RAC2020PM-OR	889419	30

S: secundario  
T: primario o secundario/final  
P: primario

S: secondary final  
T: primary or secondary final  
P: primary

S: secundario  
T: primario o secundario  
P: primario





FILTROS / FILTERS / FILTRI

FILTROS DECANTADOR  
COMPLETE FILTER  
FILTRI DECANTATORE



	RAC110A	RAC120AS	RAC230R2	RAC245R2	RAC460R2	RAC490R2
FLUJO MÁXIMO MAX. FLOW FLUSSO MASSIMO	57 l/h 15 gph	57 l/h 15 gph	114 l/h 30 gph	170 l/h 45 gph	227 l/h 60 gph	341 l/h 90 gph
ELEMENTO ELEMENT ELEMENTO	RACR11T	RACR12	RACR20	RACR25	RACR60	RACR90
DIESEL	✓	✓	✓	✓	✓	✓
GASOLINA GAS BENZINA	✓	✓				
CAZOLETA TRANSPARENTE CLEAR BOWL VASCHETTA TRASPARENTE	✗	✓	✓	✓	✓	✓
INSTALACIÓN VACUÓMETRO VACUUM INSTALLATION INSTALLAZIONE VACUOMETRO	✓	✓	✓	✓	✓	✓
INSTALACIÓN PRESIÓN PRESSURE INSTALLATION INSTALLAZIONE PRESSIONE	✓	✓	✓	✓	✓	✓
ALTURA X ANCHO X PROF. (mm) HEIGHT X WIDTH X DEPTH (mm) ALTEZZA X LARGH X PROF. (mm)	152 x 81 x 81	165 x 81 x 81	229 x 102 x 102	267 x 102 x 102	279 x 114 x 121	300 x 114 x 121
PESO WEIGHT PESO	0,59 kg	0,59 kg	0,90 kg	1 kg	1,3 kg	1,4 kg
CAIDA DE PRESIÓN PRESSURE DROP CADUTA DI PRESSIONE	0.15 PSI 0.01 bar	0.15 PSI 0.01 bar	0.31 PSI 0.02 bar	0.61 PSI 0.04 bar	0.39 PSI 0.03 bar	0.95 PSI 0.06 bar
PRESIÓN MÁXIMA MAX. PRESSURE PRESSIONE MASSIMA	100 PSI	7 PSI	30 PSI	30 PSI	30 PSI	30 PSI
TAMAÑO ENTRADA INLET SIZE DIMENSIONI ENTRATA	1/4" NPT	1/4" NPT	1/4" NPT	1/4" NPT	3/8" NPT	3/8" NPT
BOMBA CEBADO (SÓLO PARA DIESEL) PRIMER PUMP (ONLY DIESEL) POMPA (SOLO PER DIESEL)	✗	✗	✓	✓	✓	✓
Nº TOMAS NUM. OF PORTS Nº FORI	4	4	3	3	4	4
TIPO DRENAJE DRAIN TYPE TIPO DRENAGGIO	Sello positivo Positive seal Tenuta positiva	Sello positivo Positive seal Tenuta positiva	Sello positivo Positive seal Tenuta positiva	Sello positivo Positive seal Tenuta positiva	Sello positivo Positive seal Tenuta positiva	Sello positivo Positive seal Tenuta positiva
OPCIÓN SENSOR AGUA WATER SENSOR OPTION OPZIONE SENSORE ACQUA	✗	✓	✓	✓	✓	✓

ELEMENTOS DE RECAMBIO  
ELEMENT  
ELEMENTI DI RICAMBIO

REF.	MICRAS MICROM MICROM
RACR11T	10
RACR12S	2
RACR12T	10
RACR12P	30
RACR20S	2
RACR20T	10
RACR20P	30



REF.	MICRAS MICROM MICROM
RACR24S	2
RACR24T	10
RACR24P	30
RACR25S	2
RACR25T	10
RACR25P	30
RACR26S	2
RACR26T	10
RACR26P	30



REF.	MICRAS MICROM MICROM
RACR60S	2
RACR60T	10
RACR60P	30
RACR90S	2
RACR90T	10
RACR90P	30
RACR120SM	2
RACR120TM	10
RACR120P	30



S: secundario  
T: primario o secundario/final  
P: primario

S: secondary final  
T: primary or secondary final  
P: primary

S: secondario  
T: primario o secundario  
P: primario

RÁCORES PARA FILTROS  
RACORS FOR FILTER  
RACCORDI PER FILTRO



Ref.	ROSCA THREAD FILETTO	MANGUERA TUBE TUBO	PARA FILTROS FOR FILTERS PER FILTRI
RAC913-010-H10	7/8" - 14	5/8" = 16 mm	900 & 1000MA30
RAC913-010-H8	7/8" - 14	1/2" = 13 mm	900 & 1000MA30
RAC913-08-H6	3/4" - 16	3/8" = 10 mm	500MA30
RAC913-08-H8	3/4" - 16	1/2" = 13 mm	500MA30

Fabricado en latón. Para filtros RACOR.  
Made in machined brass. For RACOR filters.  
In ottone. Per filtri RACOR



Ref.	ROSCA THREAD FILETTO	MANGUERA TUBE TUBO	
GS31166	1/4"	5/16" = 7,9 mm	2
GS31155	3/8"	3/8" = 95 mm	2
GS31156	3/8"	5/16" = 7,9 mm	2



Ref.	ROSCA THREAD FILETTO	MANGUERA TUBE TUBO
BRA125-3/16x1/4	1/4"	3/16"
BRA125-1/4x1/2	1/2"	1/4"
BRA125-5/16x3/8	3/8"	5/16"
BRA125-3/8x3/8	3/8"	3/8"
BRA125-3/8x1/2	1/2"	3/8"
BRA125-1/2x3/8	3/8"	1/2"
BRA125-1/2x1/2	1/2"	1/2"
BRA125-1/2x3/4	3/4"	1/2"
BRA125-5/8x3/8	3/8"	5/8"
BRA125-5/8x1/2	1/2"	5/8"
BRA125-5/8x3/4	3/4"	5/8"
BRA125-3/4x1/2	1/2"	3/4"
BRA125-3/4x3/4	3/4"	3/4"
BRA125-1x3/4	3/4"	1"



Ref.	ROSCA THREAD FILETTO	MANGUERA TUBE TUBO
RAC1/2x16	1/2"	16 mm
RAC1/2X18	1/2"	18 mm
RAC1/2X20	1/2"	20 mm
RAC3/8X10	3/8"	10 mm
RAC3/8X12	3/8"	12 mm
RAC3/8X14	3/8"	14 mm



Latón. Para filtros RACOR 500, 900, 1000.  
Brass. For RACOR filters 500, 900, 1000.  
In ottone. Per filtri RACOR 500, 900, 1000.

Ref.	ROSCA EXT THREAD EXT FILETTO EST	ROSCA INT THREAD INT FILETTO INT	PARA FILTROS FOR FILTERS PER FILTRI
RAC1/2F-1/2M	7/8"	1/2"	900 & 1000
RAC3/8F-3/8M	3/4"	3/8"	500

Fabricado en latón.  
Made in machined brass.  
In ottone.



Ref.	ROSCA THREAD FILETTO
RAC3DO82158	1/2"



KITS

RECTOS  
STRAIGHT  
DRITTO

Ref.	MANGUERA TUBE TUBO
GS30430	8 mm
GS30431	10 mm



ORIENTABLES  
GUIDIBLE  
REGOLABILE

Ref.	MANGUERA TUBE TUBO	FILTRO FILTER FILTRO
GS30432	8 mm	REC1140639
GS30433	10 mm	



MANÓMETRO  
VACUUM GAUGE  
MANOMETRO

Ref.
RAC1606B



SENSOR DE AGUA  
WATER SENSOR  
SENSORE ACQUA



Ref.
RECRK21069

Sólo para filtros Diesel.  
No utilizar con gasolina.  
Only for diesel applications.  
Do not use with gasoline.  
Solo per filtri Diesel.  
NON benzina



RELOJ SENSOR DE AGUA  
WATER ALARM  
ALLARME SENSORE ACQUA

Ref.
RACRK20726



VALVULA DRENAJE AGUA  
DRAIN VALVE  
VALVOLA DRENAGGIO ACQUA

Ref.
RACRK19492UL



**FILTROS / FILTERS / FILTRI**

**LIMPIADOR FILTROS DE AIRE  
CLEANER AIR FILTERS  
FILTRI DELL'ARIA PULITORI**

Ref.

RACAFM82006



**LLAVE PARA CAZOLETA  
BOWL REMOVAL WRENCH  
CHIAVE PER VASCHETTA**

Ref.

RACRK22628



**FILTROS TIPO SEPAR 2000  
FILTER TYPE SEPAR 2000  
FILTRI DI TIPO SEPAR 2000**

Ref.	MICRAS MICROM MICROM	FLUJO FLOW FLUSSO	MEDIDAS MEASURE MISURE	PARA FOR PER
RECGS00530	10	300 l/h	75 x 75 x 24	3 <sup>1/16</sup> x 3 <sup>1/8</sup> x 1 <sup>3/16</sup>
RECGS01030	30	600 l/h	88 x 88 x 55	3 <sup>9/16</sup> x 3 <sup>5/8</sup> x 2 <sup>1/8</sup>
RECGS01830	30	1080 l/h	136 x 138 x 55	5 <sup>13/16</sup> x 5 <sup>7/8</sup> x 2 <sup>1/8</sup>

**NEW**



**ELEMENTOS PARA SEPAR 2000  
REPLACEMENTS FOR SEPAR 2000  
CARTUCCIA PER SEPAR 2000**

Ref.	R.O. OEM
RACPFF5600	01010
RACPFF5601	01030



RECGS01830

RECGS01030

RECGS00530

# ÍNDICE / TABLE OF CONTENTS / INDICE

## REF-->R.O. / OEM

REF.	R.O./OEM	PAG.	REF.	R.O./OEM	PAG.	REF.	R.O./OEM	PAG.			
A/P2277	A4867HA	628	BORG-W	CEF500127	48300055	682	RENAULT	FEL17040	30266	638	CRUSAD.
A/P2278		628	BORG-W	CEF500128	48300006	682	RENAULT	FEL17042	31136	638	CRUSAD.
A/P2279	1308-410-001	628	BORG-W	CEF500128	48300007	682	RENAULT	FEL17046	16.50-00259	632	CHRIS-C
A/P2280		658	HURT	CEF500129	229955	663	KOHLER	FEL17048	31137	638	CRUSAD.
A/P2281		658	HURT	CEF500129	IMP00101	685	VETUS	FEL17060	RM0032	672	PLEASURE.
A/P2293		658	HURT	CEF500131X	321.11.008	683	SOLE D	FEL17310	33393	639	CRUSAD.
ALT023941	100-238-002	628	BORG-W	CEF500135	8924838	658	DETROIT D	FEL17460		639	CRUSAD.
ALT340940	2001-238-001	628	BORG-W	CEF500135	5N9360	630	CATERPIL.	FEL17920	97686	639	CRUSAD.
ALTD4-101	1004-650-001	628	BORG-W	CEF500135		630	CATERPIL.	FEL17930	91351	639	CRUSAD.
ALTD4-102	1004-650-002	628	BORG-W	CEF500135		657	DETROIT D	GS30430		705	FILTR
ALTD4-107	1004-650-007	628	BORG-W	CEF500135		664	NANNI D	GS30431		705	FILTR
ALTD4-108	1004-650-008	628	BORG-W	CEF500135		653-654	CUMMINS	GS30432		705	FILTR
ARC50137	42090	638	CHRIS-C	CEF500145T	460027	671	PERKINS	GS30433		705	FILTR
ARC50137	42090	652	CRUSAD.	CEF500145T	5196168	658	DETROIT D	GS30435		701	FILTR
ARC50138		638	CHRIS-C	CEF500145T	4L8470	630	CATERPIL.	GS31001		701	FILTR
ARC50138		652	CRUSAD.	CEF500145T	50.06506.0089	664	MAN	GS31002		701	FILTR
ARC86050	30594	686	WESTER.	CEF500145T		657	DETROIT D	GS31065		702	FILTR
BACC47-1650-06022	1650-056022	633	CHRIS-C	CEF500146X	IMP00701	685	VETUS	GS31066		702	FILTR
BACR-29-96319	96319	644	CRUSAD.	CEF500146X		664	NANNI D	GS31067		702	FILTR
BAPE-1-6354	89058	669	PERKINS	CEF500152	8927570	658	DETROIT D	GS31155		702-705	FILTR
BRA125-1/2x1/2		705	FILTR	CEF500152	3N4859	630	CATERPIL.	GS31156		702-705	FILTR
BRA125-1/2x3/4		705	FILTR	CEF500153	23502086	658	DETROIT D	GS31157		702	FILTR
BRA125-1/2x3/8		705	FILTR	CEF500162G	51.06506.0103	664	MAN	GS31166		702-705	FILTR
BRA125-1/4x1/2		705	FILTR	CEF500164T	3802444	655	CUMMINS	GS31185		701	FILTR
BRA125-1x3/4		705	FILTR	CEF500164T	3897337	655	CUMMINS	GS31186		701	FILTR
BRA125-3/16x1/4		705	FILTR	CEF500164T	3916852	655	CUMMINS	HGE1086		656	DETROIT D
BRA125-3/4x1/2		705	FILTR	CEF500164T	3925236	655	CUMMINS	HGE2018	53-2009	659	HURT
BRA125-3/4x3/4		705	FILTR	CEF500164T	7E0321	630	CATERPIL.	HGE2018	53-2018	659	HURT
BRA125-3/8x1/2		705	FILTR	CEF500164T	1W5664	630	CATERPIL.	HGE2027	53-2027-T	659	HURT
BRA125-3/8x3/8		705	FILTR	CEF500165	229826	663	KOHLER	HOT20011	R029011	672	PLEASURE.
BRA125-5/16x3/8		705	FILTR	CEF500165	302875	687	WESTER.	HOT20775-MK	96120	639	CRUSAD.
BRA125-5/8x1/2		705	FILTR	CEF500166	11764	687	WESTER.	HOT20775-MK	96121	639	CRUSAD.
BRA125-5/8x3/4		705	FILTR	CEF500166	33100	687	WESTER.	HOT20799-MK	97114	639	CRUSAD.
BRA125-5/8x3/8		705	FILTR	CEF500166	132-0375	668	ONAN	HOT20799-MK	97115	639	CRUSAD.
CEF500100GX	24880272	671	PERKINS	CEF500166		663	KOHLER	HOT20799-MK	97992	639	CRUSAD.
CEF500100GX	132-0859	668	ONAN	CEF500167	3349198	655	CUMMINS	HOT20799-MK	97993	639	CRUSAD.
CEF500100GX		663	KOHLER	CEF500167	3916720	655	CUMMINS	HOT20899	R029001	672	PLEASURE.
CEF500100GX		670	PERKINS	CEF500177GT	3N5895	630	CATERPIL.	HOT20899-MK		672	PLEASURE.
CEF500101X	33636	687	WESTER.	CEF500179GX	3N8449	630	CATERPIL.	HOT20907	53-2009	659	HURT
CEF500101X	37431	687	WESTER.	CEF500181G	3974456	655	CUMMINS	HOT20907	53-2018	659	HURT
CEF500101X	48080	687	WESTER.	CEF500182G	1095324	630	CATERPIL.	HOT20916	97169	641	CRUSAD.
CEF500101X	434014	664	NANNI D	CEF500182G	1095327	630	CATERPIL.	HOT20916-MK		641	CRUSAD.
CEF500101X	STM8061	685	VETUS	CEF500182G	1230492	630	CATERPIL.	HOT20918	97386	641	CRUSAD.
CEF500103T	11418	687	WESTER.	CEF500182G	1237985	630	CATERPIL.	HOT20925	96120	639	CRUSAD.
CEF500103T	11907	687	WESTER.	CEF500182G	4019403	655	CUMMINS	HOT20925	97752	639	CRUSAD.
CEF500103T	22212	643	CRUSAD.	CEF500182G	4933743	655	CUMMINS	HOT20926	96121	639	CRUSAD.
CEF500103T	33104	687	WESTER.	CEF500183G	3972366	655	CUMMINS	HOT20926	97753	639	CRUSAD.
CEF500103T	1003026	643	CRUSAD.	CEF500186T	51.06506.0106	664	MAN	HOT20927	97772	641	CRUSAD.
CEF500103T	1003062	643	CRUSAD.	CEF500190G	132-0415	668	ONAN	HOT20927-MK		641	CRUSAD.
CEF500103T	24880178	671	PERKINS	CEF500190G		663	KOHLER	HOT20928	97924	641	CRUSAD.
CEF500103T	132-0117	668	ONAN	CEF500192GX		655	CUMMINS	HOT20929	97114	639	CRUSAD.
CEF500103T	132-0317	668	ONAN	CM6L2016	6L2016	632	CATERPIL.	HOT20929	97992	639	CRUSAD.
CEF500103T	NA900010	671	PERKINS	CM6L2283	6L2283	632	CATERPIL.	HOT20933	97115	639	CRUSAD.
CEF500103T		663	KOHLER	CM6L2288	6L2288	632	CATERPIL.	HOT20933	97993	639	CRUSAD.
CEF500104		673	PLEASURE.	CM8515842		657	DETROIT D	HOT20934	96560	641	CRUSAD.
CEF500105T	460027	671	PERKINS	CM8515850		657	DETROIT D	HOT20934	98068	641	CRUSAD.
CEF500105T	5193553	658	DETROIT D	CME-8	6L2285	632	CATERPIL.	HOT20938	98126	640	CRUSAD.
CEF500105T	1L4774	630	CATERPIL.	CME0	11885	686	WESTER.	HOT20939		659	HURT
CEF500106GT	5193602	658	DETROIT D	CME0	260085	662	INDMAR	HOT20982	98125	640	CRUSAD.
CEF500106GT	5196629	658	DETROIT D	CME0	267928	662	INDMAR	HOT20982-MK		640	CRUSAD.
CEF500106GT	5199148	658	DETROIT D	CME1	6L2280	632	CATERPIL.	HOT20996	R028001	672	PLEASURE.
CEF500106GT	347.11.008	683	SOLE D	CME1E		657	DETROIT D	HOT20996-MK		672	PLEASURE.
CEF500106GT	3N1906	630	CATERPIL.	CME2		657	DETROIT D	HOT20997	0994-000	659	HURT
CEF500106GT	50.06506.0091	664	MAN	CME4		657	DETROIT D	HOT20998	53-2800	659	HURT
CEF500106GT	IMP00301	685	VETUS	CME8D	6L2284	632	CATERPIL.	HOT20998		639	CRUSAD.
CEF500106GT	RC320D	682	RENAULT	DJC004	3010336	653	CUMMINS	HOT20998-MK		659	HURT
CEF500106GT		664	NANNI D	DJC004	3278137	653	CUMMINS	HOT26562-MK		641	CRUSAD.
CEF500107T	460038	671	PERKINS	DJC004		654	CUMMINS	HOT30984	98128	640	CRUSAD.
CEF500107T	24880190	671	PERKINS	DJC0819	3912139	653	CUMMINS	HOT30984-MK		640	CRUSAD.
CEF500107T	08-21-1201	668	ONAN	DJC0819	3922589	653-654	CUMMINS	JAB11979-0001		698	JABSCO
CEF500107T	131-0050	668	ONAN	DJC0820	3010336	653	CUMMINS	JAB12104-0001		698	JABSCO
CEF500107T	132-0162	668	ONAN	DJC0820	3278137	653	CUMMINS	JAB14750-0001		698	JABSCO
CEF500107T	351.11.008	683	SOLE D	DJC0820	3907458	653	CUMMINS	JAB14750-0003		698	JABSCO
CEF500107T		670	PERKINS	DJC0820	3912019	653	CUMMINS	JAB17018-0001	3N5895	630	CATERPIL.
CEF500114T	460024	671	PERKINS	DJC0820		654	CUMMINS	JAB17018-0001		698	JABSCO
CEF500114T	24880031	671	PERKINS	DJC0830	3912962	653-654	CUMMINS	JAB17370-0001	8927570	658	DETROIT D
CEF500114T	7C3286	630	CATERPIL.	DJC1730	3866493	653	CUMMINS	JAB17370-0001	3N4859	630	CATERPIL.
CEF500114T		658	DETROIT D	DJC1730	3897194	653-654	CUMMINS	JAB17370-0001		630	CATERPIL.
CEF500114T		664	NANNI D	DJC2701	3922589	653-654	CUMMINS	JAB17370-0001		698	JABSCO
CEF500116GX	24880194	671	PERKINS	DJG0815	5106016	657	DETROIT D	JAB17937-0001-P	460024	671	PERKINS
CEF500120T	13930	687	WESTER.	DJG0815	5122599	657	DETROIT D	JAB17937-0001-P	24880031	671	PERKINS
CEF500120T	20300	643	CRUSAD.	DJG0815	8924265	657	DETROIT D	JAB17937-0001-P	7C3286	630	CATERPIL.
CEF500120T	20310	643	CRUSAD.	DJG0815	23501769	657	DETROIT D	JAB17937-0001-P		664	NANNI D
CEF500120T	3908220	655	CUMMINS	DJG0815	23507972	657	DETROIT D	JAB17937-0001-P		698	JABSCO
CEF500120T	132-0292	668	ONAN	DJG0816	5107480	657	DETROIT D	JAB17938-0001-P		698	JABSCO
CEF500120T	132-0348	668	ONAN	DJG0816	5115396	657	DETROIT D	JAB17956-0001		698	JABSCO
CEF500120T	132-0349	668	ONAN	DJG0816	5186250	657	DETROIT D	JAB18777-0001-P		698	JABSCO
CEF500120T	NA900012	671	PERKINS	DJG0816	23501083	657	DETROIT D	JAB18786-0001	23502086	658	DETROIT D
CEF500120T	R061017	643	CRUSAD.	DJG0816	23507971	657	DETROIT D	JAB18786-0001	3N8449	630	CATERPIL.
CEF500121GX	434013	664	NANNI D	FEL17010	33408	638	CRUSAD.	JAB18786-0001		698	JABSCO
CEF500122T	48300008	682	RENAULT	FEL17030	6269577	672	PLEASURE.	JAB18789-0001		698	JABSCO
CEF500123X	312.11.008	683	SOLE D	FEL17030	7057500	638	CRUSAD.	JAB3085-0001		698	JABSCO
CEF500127	48300037	682	RENAULT	FEL17030	16.50-00250	632	CATERPIL.	JAB30919-0001		698	JABSCO

REF	R.O./OEM	PAG	REF	R.O./OEM	PAG	REF	R.O./OEM	PAG				
JAB4527-0001		698	JABSCO	PH300-0010	680	PLEASURE.	RACS3213	702	FILTR			
JAB5616-0001		698	JABSCO	PH300-0012	655	CUMMINS	RACS3214	702	FILTR			
JOH09-1026B	24880194	671	PERKINS	PH300-0013	RA097002	680	PLEASURE.	RACS3220UL	702	FILTR		
JOH09-1027B	460038	671	PERKINS	PH300-0013	RA097003	680	PLEASURE.	RACS3227	702	FILTR		
JOH09-1027B	24880190	671	PERKINS	PH300-0013	RA097006	680	PLEASURE.	RACS3227	702	FILTR		
JOH09-1027B	08-21-1201	668	ONAN	PH300-0014		680	PLEASURE.	RACS3228UL	702	FILTR		
JOH09-1027B	131-0050	668	ONAN	PH300-0027-OE	48200932	664	NANNI D	RACS3228UL	702	FILTR		
JOH09-1027B	132-0162	668	ONAN	PH300-0032	575010	661	INDMAR	RACS3240	702	FILTR		
JOH09-1027B	351.11.008	683	SOLE D	PH300-0032	RA097007B	681	PLEASURE.	REC016940	879194241	658	HURT	
JOH09-1027B	IMP00201	685	VETUS	PH300-0032	RA097007L	681	PLEASURE.	REC016940	8791014241	658	HURT	
JOH09-1027B		664	NANNI D	PH300-0041	575011	661	INDMAR	REC016940	35-813405	658	HURT	
JOH09-1027B		670	PERKINS	PH300-0041	RA097007	681	PLEASURE.	REC016940	35-813405A1	658	HURT	
JOH09-1027B		674	PLEASURE.	PH365-0006		652	CRUSAD.	REC016940	35-815419	658	HURT	
JOH09-1028B	5193602	658	DETROIT D	PH375-0027	R130001	681	PLEASURE.	REC016940	F19608751	658	HURT	
JOH09-1028B	5196629	658	DETROIT D	PH600-0002	17670	642	CRUSAD.	REC016940	FFF001138	658	HURT	
JOH09-1028B	5199148	658	DETROIT D	PH600-0002	30103	642	CRUSAD.	REC08000K	132-0415	667-668	ONAN	
JOH09-1028B	347.11.008	683	SOLE D	PH600-0002	67859	642	CRUSAD.	REC08000K		663	KOHLER	
JOH09-1028B	3N1906	630	CATERPIL.	PH600-0002	811573	642	CRUSAD.	REC09000K	229826	663	KOHLER	
JOH09-1028B	50.06506.0091	664	MAN	PH600-0002	RA057019	673	PLEASURE.	REC09000K	302875	687	WESTER.	
JOH09-1028B	IMP00301	685	VETUS	PH600-0005	20318	642	CRUSAD.	REC09000K		663	KOHLER	
JOH09-1028B	RC320D	682	RENAULT	PH600-0005	7142520	642	CRUSAD.	REC09140	NA001175	670	PERKINS	
JOH09-1028B		664	NANNI D	PH600-0005	RA057018	673	PLEASURE.	REC10077K		11764	687	WESTER.
JOH09-1029B	460027	671	PERKINS	PH600-0006	RA057004	673	PLEASURE.	REC10077K	33100	687	WESTER.	
JOH09-1029B	5193553	658	DETROIT D	PH600-0006		642	CRUSAD.	REC10077K	132-0375	668	ONAN	
JOH09-1029B	1L4774	630	CATERPIL.	PH600-0006		705	FILTR	REC10077K		663	KOHLER	
JOH09-802B		660	INDMAR	RAC1/2F-1/2M		705	FILTR	REC10077K		666	ONAN	
JOH09-806B	24880272	671	PERKINS	RAC1/2x18		705	FILTR	REC10077K		687	WESTER.	
JOH09-806B	132-0859	668	ONAN	RAC1/2X20		705	FILTR	REC10615K	13930	687	WESTER.	
JOH09-808B	434013	664	NANNI D	RAC1000MA30		703	FILTR	REC10615K	20300	643	CRUSAD.	
JOH09-810B	33636	687	WESTER.	RAC110A		704	FILTR	REC10615K	20310	643	CRUSAD.	
JOH09-810B	37431	687	WESTER.	RAC120AS		704	FILTR	REC10615K	3908220	655	CUMMINS	
JOH09-810B	40800	687	WESTER.	RAC120R-RAC-01		702	FILTR	REC10615K	132-0292	668	ONAN	
JOH09-810B	434014	664	NANNI D	RAC1606B		705	FILTR	REC10615K	132-0348	668	ONAN	
JOH09-810B	STM8061	685	VETUS	RAC2010PM-OR	3581760	703	FILTR	REC10615K	132-0349	668	ONAN	
JOH09-814B	5196168	658	DETROIT D	RAC2010SM-OR	1147147	703	FILTR	REC10615K	NA900012	671	PERKINS	
JOH09-814B	4L8470	630	CATERPIL.	RAC2010TM-OR	861014	703	FILTR	REC10615K	R061017	643	CRUSAD.	
JOH09-814B	50.06506.0089	664	MAN	RAC2020PM-OR	889419	703	FILTR	REC10615K		663	KOHLER	
JOH09-814B		664	NANNI D	RAC2020SM-OR	889425	703	FILTR	REC10615K		667	ONAN	
JOH09-819B	8924838	658	DETROIT D	RAC2020TM-OR	3838854	703	FILTR	REC10615K		653-654	CUMMINS	
JOH09-819B	5N9360	630	CATERPIL.	RAC2040PM-OR	889419	703	FILTR	REC1140639		703-705	FILTR	
JOH09-820B	51.06506.0106	664	MAN	RAC2040SM-OR	889421	703	FILTR	REC12-835467Q01	R096116	681	PLEASURE.	
JOH09-821B	51.06506.0103	664	MAN	RAC2040TM-OR	3838852	703	FILTR	REC120		703	FILTR	
JOH09-842B	51.06506.0127	664	MAN	RAC230R2		704	FILTR	REC1220185	1220185	665	ONAN	
LENS3213		702	FILTR	RAC23289-10		701	FILTR	REC1220185	122-0185	665	ONAN	
LENS3227		702	FILTR	RAC23299-10		701	FILTR	REC1220550	122-0550	666	ONAN	
LENS3232		702	FILTR	RAC245R2		704	FILTR	REC1220602	1220602	666	ONAN	
LENS3240		702	FILTR	RAC3/8F-3/8M		705	FILTR	REC1220716712	122.0716.712	666	ONAN	
MAG15-803		651	CRUSAD.	RAC3/8X10		705	FILTR	REC1220810	1220810	666	ONAN	
MAG15-803		661	INDMAR	RAC3/8X12		705	FILTR	REC1220810	122-0810	666	ONAN	
MAG15-803		661	INDMAR	RAC3/8X14		705	FILTR	REC122B326	122B326	665	ONAN	
MAG15-809		661	INDMAR	RAC320R-INOX-01		702	FILTR	REC12532	12532	647	CRUSAD.	
MAG15-809		679	PLEASURE.	RAC320R-INOX-02		702	FILTR	REC12532	16.69-00100	635	CHRIS-C	
MAR345	3776F024	669	PERKINS	RAC320R-RAC-01		702	FILTR	REC12532	F16900165	635	CHRIS-C	
MAR906	135616660	669	PERKINS	RAC320R-RAC-02		702	FILTR	REC12644A1		633	CHRIS-C	
OSC0959	1650-05944	633	CHRIS-C	RAC320R-RAC-03		702	FILTR	REC12644A1		642	CRUSAD.	
OSC7169-MK		641	CRUSAD.	RAC3DO82158		705	FILTR	REC12644A1		673	PLEASURE.	
OSC7214-MK		672	PLEASURE.	RAC460R2		704	FILTR	REC128000-5720	128000-5720	631	CATERPIL.	
OSC7387	97387	642	CRUSAD.	RAC490R-RAC-01		702	FILTR	REC1396-4148	RNO067	675	PLEASURE.	
OSC7624	97624	642	CRUSAD.	RAC490R2		704	FILTR	REC1396-4656	RNO116	675	PLEASURE.	
OSC775-MK	96120	639	CRUSAD.	RAC500MA30		703	FILTR	REC1396-4656	RNO116-2	675	PLEASURE.	
OSC775-MK	96121	639	CRUSAD.	RAC75/1000MA30		703	FILTR	REC1396-5238	RNO118	675	PLEASURE.	
OSC7772-MK		641	CRUSAD.	RAC75/500MAX		703	FILTR	REC1396-5238	RNO120	675	PLEASURE.	
OSC8128-MK		640	CRUSAD.	RAC900MA30		703	FILTR	REC1397-2060	45303	646	CRUSAD.	
OSC8243-MK		640	CRUSAD.	RAC913-010-H10		705	FILTR	REC1397-2060		635	CHRIS-C	
OSC9015G		640	CRUSAD.	RAC913-010-H8		705	FILTR	REC1397-2060		645	CRUSAD.	
OSC992-MK		660	HURT	RAC913-08-H6		705	FILTR	REC1397-3327		635	CHRIS-C	
OSC994-MK		659	HURT	RAC913-08-H8		705	FILTR	REC1397-3327		645-646	CRUSAD.	
PAF4-05000300		701	FILTR	RACAFM82006		706	FILTR	REC1463-9382	37068	651	CRUSAD.	
PH140-0004	987811	680	PLEASURE.	RACPFF5510		701	FILTR	REC1463-9382	51080	651	CRUSAD.	
PH140-0004	RA122001	680	PLEASURE.	RACPFF5600		706	FILTR	REC1463-9382	R117001	679	PLEASURE.	
PH140-0004	RK122014	680	PLEASURE.	RACPFF5601		706	FILTR	REC1463-9382		637	CHRIS-C	
PH140-0004-CCW		680	PLEASURE.	RACR11T		704	FILTR	REC1463-9382		660	INDMAR	
PH140-0013	107399	652	CRUSAD.	RACR120P		704	FILTR	REC149-0428	149-0428	665	ONAN	
PH140-0013	1109486	652	CRUSAD.	RACR120SM		704	FILTR	REC149-2106	149-2106	665	ONAN	
PH140-0013	16.61-0042	638	CHRIS-C	RACR120TM		704	FILTR	REC1491754	1491754	665	ONAN	
PH140-0013	16.61-0043	638	CHRIS-C	RACR12P		704	FILTR	REC1491758	1491758	665	ONAN	
PH140-0013		680	PLEASURE.	RACR12S		704	FILTR	REC1492250I	1492250	665	ONAN	
PH140-0015	1109482	652	CRUSAD.	RACR12T		704	FILTR	REC1492251II	1492251	665	ONAN	
PH140-0015		680	PLEASURE.	RACR20P		704	FILTR	REC15-401		661	INDMAR	
PH140-0017-D	RA122015	652	CRUSAD.	RACR20S		704	FILTR	REC15-405		661	INDMAR	
PH140-0017-D		680	PLEASURE.	RACR20T		704	FILTR	REC15-601		651	CRUSAD.	
PH140-0022	33486	686	WESTER.	RACR24P		704	FILTR	REC15-601		661	INDMAR	
PH140-0022	42090	652	CRUSAD.	RACR24S		704	FILTR	REC15-602		661	INDMAR	
PH140-0022	573001	661	INDMAR	RACR24T		704	FILTR	REC15-604		651	CRUSAD.	
PH140-0022	1109484	652	CRUSAD.	RACR25P		704	FILTR	REC15-604		661	INDMAR	
PH140-0022	9000888	679	PLEASURE.	RACR25S		704	FILTR	REC15-604		679	PLEASURE.	
PH140-0022	19010617	652	CRUSAD.	RACR25T		704	FILTR	REC15-801		651	CRUSAD.	
PH140-0022	RA122008	652	CRUSAD.	RACR26P		704	FILTR	REC15-801		661	INDMAR	
PH140-0022	RA122008	679	PLEASURE.	RACR26S		704	FILTR	REC15-801		679	PLEASURE.	
PH140-0022-CCW	42091	652	CRUSAD.	RACR26T		704	FILTR	REC15-805		651	CRUSAD.	
PH140-0022-CCW	1109485	652	CRUSAD.	RACR60P		704	FILTR	REC15-806		661	INDMAR	
PH140-0022-CCW	9000888	652	CRUSAD.	RACR60S		704	FILTR	REC15-806		679	PLEASURE.	
PH140-0022-CCW	19010615	652	CRUSAD.	RACR60T		704	FILTR	REC15000K	3349198	655	CUMMINS	
PH140-0022-CCW	RA122009	652	CRUSAD.	RACR90P		704	FILTR	REC15000K	3916720	655	CUMMINS	
PH140-0022-CCW	RA122009	679	PLEASURE.	RACR90S		704	FILTR	REC15000K		653-654	CUMMINS	
PH140-0022-CCW		661	INDMAR	RACR90T		704	FILTR	REC17000K	3802444	655	CUMMINS	
PH150-0008	3904445	655	CUMMINS	RACRK19492UL		705	FILTR	REC17000K	3897337	655	CUMMINS	
PH150-0008	3916854	655	CUMMINS	RACRK20726		705	FILTR	REC17000K	3916852	655	CUMMINS	
PH300-0007		680	PLEASURE.	RACRK22628		706	FILTR	REC17000K	3925236	655	CUMMINS	

REF.	R.O./OEM	PAG		REF.	R.O./OEM	PAG		REF.	R.O./OEM	PAG	
REC17000K	7E0321	630	CATERPIL.	REC33662	16.69-00050	636	CHRIS-C	REC392-6324Q1		677	PLEASURE.
REC17000K	1W5664	630	CATERPIL.	REC33662	R115002	677	PLEASURE.	REC392-6330		677	PLEASURE.
REC17000K		653-654	CUMMINS	REC33706	12526	648	CRUSAD.	REC392-9086T	41069	647	CRUSAD.
REC17177A1	37061	649	CRUSAD.	REC33706		636	CHRIS-C	REC392-9086T		676	PLEASURE.
REC17177A1		637	CHRIS-C	REC33708	12528	648	CRUSAD.	REC392-9766	41076	647	CRUSAD.
REC17177A1		677	PLEASURE.	REC33765T		635	CHRIS-C	REC392-9766	RA108003	676	PLEASURE.
REC17370-0001	8927570	658	DETROIT D	REC33765T		647	CRUSAD.	REC392-9766		635	CHRIS-C
REC17937-0001	460024	671	PERKINS	REC34235T	16.69-00049	636	CHRIS-C	REC3922122	3922122	653	CUMMINS
REC17937-0001	24880031	671	PERKINS	REC34235T		648	CRUSAD.	REC3922122	4019951	653	CUMMINS
REC17937-0001		664	NANNI D	REC3423A1		636	CHRIS-C	REC3922122	4020066	653	CUMMINS
REC17937-0001		657-658	DETROIT D	REC3423A1		649	CRUSAD.	REC393-4988	3000121	647	CRUSAD.
REC18-5295		678	PLEASURE.	REC34765A2		633	CHRIS-C	REC393-4988		676	PLEASURE.
REC18-8112		643	CRUSAD.	REC34765A2		642	CRUSAD.	REC393-9459Q1	16.69-00052	635	CHRIS-C
REC18-8114		635	CHRIS-C	REC34765A2		673	PLEASURE.	REC393-9459Q1	3N4851	630	CATERPIL.
REC18-8114		646	CRUSAD.	REC35-06003	201104	645	CRUSAD.	REC393-9459Q1		630	CATERPIL.
REC18-8114		660	INDMAR	REC35-06003	16.81-08746	634	CHRIS-C	REC40135		701	FILTR
REC18-8115		635	CHRIS-C	REC35-06003	R077002	675	PLEASURE.	REC40145		701	FILTR
REC18-8115		646	CRUSAD.	REC35-06003		666	ONAN	REC40155		701	FILTR
REC18-8115		660	INDMAR	REC35-06007	9002514	645	CRUSAD.	REC40165		701	FILTR
REC18000K	1095324	630	CATERPIL.	REC35-06007	16.81-06536	634	CHRIS-C	REC48080	33636	687	WESTER.
REC18000K	1095327	630	CATERPIL.	REC35-06007	R077001	675	PLEASURE.	REC48080	37431	687	WESTER.
REC18000K	1230492	630	CATERPIL.	REC35-802893Q		701	FILTR	REC48080	48080	687	WESTER.
REC18000K	1237985	630	CATERPIL.	REC35-802893Q01		701	FILTR	REC502900	279449	662	INDMAR
REC18000K	4019403	655	CUMMINS	REC35-80365M		701	FILTR	REC5145578	7260	657	DETROIT D
REC18000K	4933743	655	CUMMINS	REC35-816168	2654347	669	PERKINS	REC5145578	17030	657	DETROIT D
REC185-2133	185-2133	666	ONAN	REC35-816168	2654407	669	PERKINS	REC5145578	17050	657	DETROIT D
REC1855835	1855835	666	ONAN	REC35-8M0061975	98041	644	CRUSAD.	REC5145578	5145576	657	DETROIT D
REC1855835	185-5835	666	ONAN	REC3517857		645	CRUSAD.	REC5145578	5145577	657	DETROIT D
REC1870014	187.0014	666	ONAN	REC3517857		675	PLEASURE.	REC5145578	5145578	657	DETROIT D
REC18786-0001	23502086	657-658	DETROIT D	REC3517857		682	RENAULT	REC5197221	5197221	657	DETROIT D
REC21213660	460038	671	PERKINS	REC35595	35595	686	WESTER.	REC58033	3000124	648	CRUSAD.
REC21213660	24880190	671	PERKINS	REC3581078	2656017	669	PERKINS	REC58217	16.69-00051	636	CHRIS-C
REC21213660	08-21-1201	668	ONAN	REC3581078		703	FILTR	REC58217		649	CRUSAD.
REC21213660	131-0050	668	ONAN	REC3586494	24880272	671	PERKINS	REC5N9357	5N9357	630	CATERPIL.
REC21213660	132-0162	668	ONAN	REC3586494	132-0859	668	ONAN	REC62092T	982063	644	CRUSAD.
REC21213660	351.11.008	683	SOLE D	REC3586496	434013	664	NANNI D	REC62092T		674	PLEASURE.
REC21213660	IMP00201	685	VETUS	REC3593573	3N5895	630	CATERPIL.	REC64851	1869704	636	CHRIS-C
REC21213660		660	INDMAR	REC3593573	24880194	671	PERKINS	REC64851		677	PLEASURE.
REC21213660		664	NANNI D	REC3604654RX	3604654RX	655	CUMMINS	REC653-0001	33636	687	WESTER.
REC21213660		670	PERKINS	REC36450	36450	686	WESTER.	REC653-0001	37431	687	WESTER.
REC21302969	185086610	671	PERKINS	REC36918	36918	686	WESTER.	REC653-0001	48080	687	WESTER.
REC21302969	185086620	671	PERKINS	REC38100	38100	686	WESTER.	REC653-0001	434014	664	NANNI D
REC21323043	185086600	671	PERKINS	REC3841697	5193602	658	DETROIT D	REC653-0001	STM8061	685	VETUS
REC21323043	163-3361	631	CATERPIL.	REC3841697	5196629	658	DETROIT D	REC653-0001		687	WESTER.
REC21622232		678	PLEASURE.	REC3841697	5199148	658	DETROIT D	REC65864	3000122	649	CRUSAD.
REC21707134	1R-0658	631	CATERPIL.	REC3841697	347.11.008	683	SOLE D	REC71831		676	PLEASURE.
REC21730344	5N9360	630	CATERPIL.	REC3841697	3N1906	630	CATERPIL.	REC76270T	96358	644	CRUSAD.
REC21730344		664	NANNI D	REC3841697	50.06506.0091	664	MAN	REC7C3613	7C3613	629	CATERPIL.
REC22024631	R020027	675	PLEASURE.	REC3841697	IMP00301	685	VETUS	REC7C3614	7C3614	630	CATERPIL.
REC22779-0001	229955	663	KOHLER	REC3841697	RC320D	682	RENAULT	REC803149	R084003	676	PLEASURE.
REC22779-0001	250872	663	KOHLER	REC3841697		664	NANNI D	REC805222A1	RA107039E	650	CRUSAD.
REC22779-0001	IMP00101	685	VETUS	REC3850397	47002	647	CRUSAD.	REC805222A1	RA107039E	678	PLEASURE.
REC229678	229678	662	INDMAR	REC3850559	201104	645	CRUSAD.	REC805226A1	47032	647	CRUSAD.
REC23-3665		662	INDMAR	REC3850559		634	CHRIS-C	REC805229A1	33628	646	CRUSAD.
REC23-3666		662	INDMAR	REC3850559		675	PLEASURE.	REC807964A1		650	CRUSAD.
REC23-99291	R094020A	681	PLEASURE.	REC3852455	RM0007	672	PLEASURE.	REC807964A1		678	PLEASURE.
REC23535447	23525200	657	DETROIT D	REC3853801	41074	648	CRUSAD.	REC817377		649	CRUSAD.
REC23535447	23535477	657	DETROIT D	REC3853801	41089	648	CRUSAD.	REC823426A1	45334	635	CHRIS-C
REC23535447	17540-0001	657	DETROIT D	REC3853801	R103004	677	PLEASURE.	REC823426A1	45334	645	CRUSAD.
REC23535447	17540-0201	657	DETROIT D	REC3853801		636	CHRIS-C	REC823426A1		645	CRUSAD.
REC24942		701	FILTR	REC3854001		650	CRUSAD.	REC823427A1		635	CHRIS-C
REC24950		701	FILTR	REC3854002	7243200	651	CRUSAD.	REC823427A1		645	CRUSAD.
REC24952		701	FILTR	REC3854003	7243110	650	CRUSAD.	REC82745		673	PLEASURE.
REC252898	252898	662	INDMAR	REC3854161	3854161	651	CRUSAD.	REC834337	359771	662	INDMAR
REC26901		637	CHRIS-C	REC3854260		648	CRUSAD.	REC834975	41059	648	CRUSAD.
REC26901		650	CRUSAD.	REC3854261	3854261	649	CRUSAD.	REC834975	R103003	677	PLEASURE.
REC26901		678	PLEASURE.	REC3854286	11418	687	WESTER.	REC834975		636	CHRIS-C
REC26902		637	CHRIS-C	REC3854286	11907	687	WESTER.	REC834975		660	INDMAR
REC26902		650	CRUSAD.	REC3854286	33104	687	WESTER.	REC835702	41052	647	CRUSAD.
REC26902		678	PLEASURE.	REC3854286	1003026	643	CRUSAD.	REC835702	18-5399	635	CHRIS-C
REC26903		637	CHRIS-C	REC3854286	24880178	671	PERKINS	REC835702	RA108002	676	PLEASURE.
REC26903		650	CRUSAD.	REC3854286	132-0117	668	ONAN	REC836-0001	460027	671	PERKINS
REC26903		678	PLEASURE.	REC3854286	132-0317	668	ONAN	REC836-0001	5193553	658	DETROIT D
REC26904		637	CHRIS-C	REC3854286	NA900010	671	PERKINS	REC836-0001	1L4774	630	CATERPIL.
REC26904		650	CRUSAD.	REC3854286		663	KOHLER	REC841243	12531	648	CRUSAD.
REC26904		678	PLEASURE.	REC3854286		667	ONAN	REC841243	1003318	648	CRUSAD.
REC27-14250	20129	639	CRUSAD.	REC3854286		687	WESTER.	REC841243	16.69-00042	636	CHRIS-C
REC27-33395	96306	639	CRUSAD.	REC3854311		649	CRUSAD.	REC841994		645	CRUSAD.
REC27-33395	CHV-47-000	672	PLEASURE.	REC3854331		648	CRUSAD.	REC847741	1R-0714	631	CATERPIL.
REC27-34213	3705042	674	PLEASURE.	REC3854548	38070	648	CRUSAD.	REC855686		701	FILTR
REC27-34213	16.50-00074	634	CHRIS-C	REC3854549	38071	649	CRUSAD.	REC855694	1004-650-006	628	BORG-W
REC27-344861	16.50-00162	637	CHRIS-C	REC3855194	47033	647	CRUSAD.	REC85785A2	97214	646	CRUSAD.
REC27-34897	16.50-00078	633	CHRIS-C	REC3855276	981650	644	CRUSAD.	REC85785A2	97595	646	CRUSAD.
REC27-34898	16.50-005756	634	CHRIS-C	REC3860703	40070	643	CRUSAD.	REC861907		669	PERKINS
REC27-99757	97498	639	CRUSAD.	REC3860703	685011	660	INDMAR	REC86234A4		634	CHRIS-C
REC27000K	3974456	655	CUMMINS	REC3860703	RA057023	673	PLEASURE.	REC875697	460027	671	PERKINS
REC29000K		655	CUMMINS	REC3860703	RA057026	673	PLEASURE.	REC875697	5196168	658	DETROIT D
REC29350-1001	GM58527	663	KOHLER	REC3861267	R117012	679	PLEASURE.	REC875697	4L8470	630	CATERPIL.
REC29350-1001	M20	670	PERKINS	REC391-5090	20117	648	CRUSAD.	REC875697	50.06506.0089	664	MAN
REC300-00879		637	CHRIS-C	REC391-5090	16.69-00039	636	CHRIS-C	REC882571	882571	656	CUMMINS
REC300-00879		651	CRUSAD.	REC391-5090	R114001	676	PLEASURE.	REC882571	8M0084523	656	CUMMINS
REC300-00879		679	PLEASURE.	REC391-5090	R114004	676	PLEASURE.	REC8923363	18760	657	DETROIT D
REC300-0539		629	CATERPIL.	REC391-5090Q1		636	CHRIS-C	REC8923363	8923363	657	DETROIT D
REC32-86036	R085035	681	PLEASURE.	REC391-5090Q1		649	CRUSAD.	REC8923363	23507475	657	DETROIT D
REC3302-9031		645-646	CRUSAD.	REC391-5090Q1		677	PLEASURE.	REC8923363	23507476	657	DETROIT D
REC33662	41057	636	CHRIS-C	REC392-6316	RA107001	677	PLEASURE.	REC8923363	23507477	657	DETROIT D
REC33662	41057	648	CRUSAD.	REC392-6316		649	CRUSAD.	REC8923363	23507973	657	DETROIT D
REC33662	705787	648	CRUSAD.	REC392-6324Q1		636	CHRIS-C	REC89260		633	CHRIS-C
REC33662	755017	660	INDMAR	REC392-6324Q1		649	CRUSAD.	REC89260		642	CRUSAD.

REF.	R.O./OEM	PAG	
REC89260		673	PLEASURE.
REC892615002	R020035A	676	PLEASURE.
REC8927296	18780	657	DETROIT D
REC8927296	18789	657	DETROIT D
REC8927296	8927296	657	DETROIT D
REC897367	R096081	681	PLEASURE.
REC898253013	R103011	677	PLEASURE.
REC89825302	20223	648	CRUSAD.
REC89825302	16.69-00149	636	CHRIS-C
REC89825302	R103001	677	PLEASURE.
REC898253T22	RA108009	676	PLEASURE.
REC8HC2023K	796351	631	CATERPIL.
REC8M0068784	700425	646	CRUSAD.
REC8M0068784	RO200001	675	PLEASURE.
REC8M0089715	R026002E	674	PLEASURE.
REC8M0091470	97895	644	CRUSAD.
REC8M6001217	12530	648	CRUSAD.
REC8M6001217	16.69-00040	636	CHRIS-C
REC8M6001217	R115001	677	PLEASURE.
REC8M6001219	41058	648	CRUSAD.
REC8M6001219	751007	660	INDMAR
REC8M6001219	R114002	676	PLEASURE.
REC8M6001219		636	CHRIS-C
REC8M6001249		636	CHRIS-C
REC8M6001249		648	CRUSAD.
REC8M6001249		677	PLEASURE.
REC8N2250	1W6586	629	CATERPIL.
REC8N2250	8N2250	629	CATERPIL.
REC90301-ZW1-003R017006		681	PLEASURE.
REC90508-ZW1-003R096117		681	PLEASURE.
REC93568		645	CRUSAD.
REC96216	96216	642	CRUSAD.
REC96562	96562	641	CRUSAD.
REC97258A1	700427	646	CRUSAD.
REC97361	97361	644	CRUSAD.
REC97361	RP026002E	674	PLEASURE.
REC982209	20222	647	CRUSAD.
REC982209	16.69-00148	635	CHRIS-C
REC982209	R108001	676	PLEASURE.
REC982230	91606	644	CRUSAD.
REC98243	98243	640	CRUSAD.
RECDF238-M1		631	CATERPIL.
RECDF4408-4		631	CATERPIL.
RECDF477-M-3		656	CUMMINS
RECFF124		682	RENAULT
RECFF143		682	RENAULT
RECFF346		682	RENAULT
RECFF425		682	RENAULT
RECFF436		682	RENAULT
RECFF477		682	RENAULT
RECFF536		682	RENAULT
RECFS00530		706	FILTR
RECFS01030		706	FILTR
RECFS01830		706	FILTR
RECRK21069		705	FILTR
RM35-802893Q		701	FILTR
RM841812		664	NANNI D
RM861906	135616660	669	PERKINS
SED3092200		669	PERKINS
SED3092201		669	PERKINS
SHE08000K	132-0415	667-668	ONAN
SHE08000K		663	KOHLER
SHE08000K		688-691-696	SHERWOOD
SHE09000K	229826	663	KOHLER
SHE09000K	302875	687	WESTER.
SHE09000K		667	ONAN
SHE09000K		691-696	SHERWOOD
SHE09959K	11418	687	WESTER.
SHE09959K	11907	687	WESTER.
SHE09959K	33104	687	WESTER.
SHE09959K	1003026	643	CRUSAD.
SHE09959K	24880178	671	PERKINS
SHE09959K	132-0117	668	ONAN
SHE09959K	132-0317	668	ONAN
SHE09959K	NA900010	671	PERKINS
SHE09959K	RP061015	674	PLEASURE.
SHE09959K		663	KOHLER
SHE09959K		667	ONAN
SHE09959K		670	PERKINS
SHE09959K		673	PLEASURE.
SHE09959K		688-689-690-691-696	SHERWOOD
SHE10077K	11764	687	WESTER.
SHE10077K	33100	687	WESTER.
SHE10077K	132-0375	668	ONAN
SHE10077K	16.80-90047	634	CHRIS-C
SHE10077K		663	KOHLER
SHE10077K		667	ONAN
SHE10077K		688-691-696	SHERWOOD
SHE10187		696	SHERWOOD
SHE10615K	13930	687	WESTER.
SHE10615K	20300	643	CRUSAD.
SHE10615K	20310	643	CRUSAD.
SHE10615K	3908220	655	CUMMINS
SHE10615K	132-0292	668	ONAN
SHE10615K	132-0348	668	ONAN
SHE10615K	132-0349	668	ONAN
SHE10615K	16.80-90131	634	CHRIS-C
SHE10615K	NA900012	671	PERKINS

REF.	R.O./OEM	PAG	
SHE10615K	R061017	643	CRUSAD.
SHE10615K	RP061017	674	PLEASURE.
SHE10615K		654	CUMMINS
SHE10615K		663	KOHLER
SHE10615K		667	ONAN
SHE10615K		670	PERKINS
SHE10615K		674	PLEASURE.
SHE10615K		688-689-690-691-696	SHERWOOD
SHE10927	20309	643	CRUSAD.
SHE10996		688	SHERWOOD
SHE10997		691	SHERWOOD
SHE10999		670	PERKINS
SHE10999		689-690-691	SHERWOOD
SHE11068		670	PERKINS
SHE11068		689-690	SHERWOOD
SHE12221		670	PERKINS
SHE12665		667	ONAN
SHE12665		691	SHERWOOD
SHE12665		688-689	SHERWOOD
SHE12859	40057	643	CRUSAD.
SHE12937		691	SHERWOOD
SHE12980		670	PERKINS
SHE12980		691	SHERWOOD
SHE15000K	3349198	655	CUMMINS
SHE15000K	3916720	655	CUMMINS
SHE15000K		654	CUMMINS
SHE15000K		689-690-696	SHERWOOD
SHE17000K	3802444	655	CUMMINS
SHE17000K	3897337	655	CUMMINS
SHE17000K	3916852	655	CUMMINS
SHE17000K	3925236	655	CUMMINS
SHE17000K	7E0321	630	CATERPIL.
SHE17000K	1W5664	630	CATERPIL.
SHE17000K		630	CATERPIL.
SHE17000K		654	CUMMINS
SHE17000K		688-689-690-689	SHERWOOD
SHE18000K	4019403	655	CUMMINS
SHE18000K	4933743	655	CUMMINS
SHE18000K		658	DETROIT D
SHE18000K		696	SHERWOOD
SHE18655		689	SHERWOOD
SHE22000K	3N8449	630	CATERPIL.
SHE22000K		696	SHERWOOD
SHE22276		667	ONAN
SHE22276		691	SHERWOOD
SHE23973		630	CATERPIL.
SHE23973		689	SHERWOOD
SHE23975		630	CATERPIL.
SHE23975		689	SHERWOOD
SHE23976		654	CUMMINS
SHE23976		667	ONAN
SHE23976		688-689-690-691	SHERWOOD
SHE23977		654	CUMMINS
SHE23977		667	ONAN
SHE23977		690-691	SHERWOOD
SHE23979		667	ONAN
SHE23979		688-689-691	SHERWOOD
SHE23980		654	CUMMINS
SHE23980		689-690	SHERWOOD
SHE23981		654	CUMMINS
SHE23981		689-690	SHERWOOD
SHE24025		688-691	SHERWOOD
SHE24841		654	CUMMINS
SHE24841		690	SHERWOOD
SHE24842		654	CUMMINS
SHE24842		690	SHERWOOD
SHE25017		630	CATERPIL.
SHE25017		690	SHERWOOD
SHE25029		689	SHERWOOD
SHE25044		654	CUMMINS
SHE25044		690	SHERWOOD
SHE25045		654	CUMMINS
SHE25045		690	SHERWOOD
SHE25105	17000	696	SHERWOOD
SHE25105	18000	696	SHERWOOD
SHE25105	22000	696	SHERWOOD
SHE25105	26000	696	SHERWOOD
SHE25106	27000	696	SHERWOOD
SHE25121		630	CATERPIL.
SHE25121		689-690	SHERWOOD
SHE25122		654	CUMMINS
SHE25122		688	SHERWOOD
SHE25123		630	CATERPIL.
SHE25123		689	SHERWOOD
SHE25123		690	SHERWOOD
SHE25124		654	CUMMINS
SHE25124		688	SHERWOOD
SHE25125		654	CUMMINS
SHE25125		690	SHERWOOD
SHE25126		654	CUMMINS
SHE25126		690	SHERWOOD
SHE25146		630	CATERPIL.
SHE25146		689	SHERWOOD
SHE25147		630	CATERPIL.
SHE25147		689	SHERWOOD

REF.	R.O./OEM	PAG	
SHE25148		630	CATERPIL.
SHE25148		689	SHERWOOD
SHE25154		630	CATERPIL.
SHE25154		690	SHERWOOD
SHE25195		691	SHERWOOD
SHE25196		691	SHERWOOD
SHE26000K	3972366	654-655	CUMMINS
SHE26000K		690-696	SHERWOOD
SHE27000K	3974456	654-655	CUMMINS
SHE27000K		690-696	SHERWOOD
SHE29000K		630	CATERPIL.
SHE29000K		654-655	CUMMINS
SHE29000K		689-690-696	SHERWOOD
SHE30000K		630	CATERPIL.
SHE30000K		690-696	SHERWOOD
SHE4257	20292	643	CRUSAD.
SHEE35	97179	643	CRUSAD.
SHEE35		689	SHERWOOD
SHEG1010	132-0343	667	ONAN
SHEG1010	132-0347	667	ONAN
SHEG1010	132-0356	667	ONAN
SHEG1010	132-0413	667	ONAN
SHEG1010		691	SHERWOOD
SHEG1012	132-0464	667	ONAN
SHEG151		689	SHERWOOD
SHEG155		689	SHERWOOD
SHEG157		690	SHERWOOD
SHEG21	RA57007	673	PLEASURE.
SHEG21		689	SHERWOOD
SHEG2603X	3922589	654	CUMMINS
SHEG2603X	3967246	654	CUMMINS
SHEG2603X		654	CUMMINS
SHEG2603X		690	SHERWOOD
SHEG2902X	196-8895	629-630	CATERPIL.
SHEG2902X		689	SHERWOOD
SHEG2903X	3349392	654	CUMMINS
SHEG2903X	4929178	654	CUMMINS
SHEG2903X	5260393	654	CUMMINS
SHEG2903X		690	SHERWOOD
SHEG2904X	123-0471	629	CATERPIL.
SHEG2904X	197-1328	629	CATERPIL.
SHEG2904X		630	CATERPIL.
SHEG2904X		689	SHERWOOD
SHEG30-2B	16.80-18346	633	CHRIS-C
SHEG3001X	147-7850	630	CATERPIL.
SHEG3001X	212-7264	630	CATERPIL.
SHEG3001X		630	CATERPIL.
SHEG3001X		690	SHERWOOD
SHEG65	NA003335	670	PERKINS
SHEG65		690	SHERWOOD
SHEG702	132-0358	666	ONAN
SHEG702	132-0459	666	ONAN
SHEG702		688	SHERWOOD
SHEG8001	132-0275	663	KOHLER
SHEG8001		691	SHERWOOD
SHEG8002	132-0395	667	ONAN
SHEG8002	132-0430	667	ONAN
SHEG8002		688	SHERWOOD
SHEG906	246489	663	KOHLER
SHEG906	267373	663	KOHLER
SHEG906	344089	663	KOHLER
SHEG906		691	SHERWOOD
SHEG907P	344085	663	KOHLER
SHEG907P	344371	663	KOHLER
SHEG907P		691	SHERWOOD
SHEG910P	GM46936	663	KOHLER
SHEG910P		691	SHERWOOD
SHEG9901		688	SHERWOOD
SHEG9903		688	SHERWOOD
SHEGC1	3912962	653-654	CUMMINS
SHEGC1		690	SHERWOOD
SHEGC5	39127684	654	CUMMINS
SHEGC5		690	SHERWOOD
SHEGC5		690	SHERWOOD
SHEH5	NA005576	670	PERKINS
SHEH5		691	SHERWOOD
SHEK75B	132-0275	667	ONAN
SHEK75B	135-0278	667	ONAN
SHEK75B		691	SHERWOOD
SHEL10B	1320278	667	ONAN
SHEL10B	132-0278	667	ONAN
SHEL10B		691	SHERWOOD
SHEM71	3010336	653	CUMMINS
SHEM71	3278137	653	CUMMINS
SHEM71	3907458	653	CUMMINS
SHEM71	3912019	653	CUMMINS
SHEM71		654	CUMMINS
SHEM71		690	SHERWOOD
SHEP1014	40050	643	CRUSAD.
SHEP1014	40050	674	PLEASURE.
SHEP1014		689	SHERWOOD
SHEP1016	854179001	654	CUMMINS
SHEP1016	879312023	654	CUMMINS
SHEP1016		688	SHERWOOD
SHEP1710C	0	629	CATERPIL.
SHEP1710C	4P-7168	629	CATERPIL.
SHEP1710C		630	CATERPIL.
SHEP1710C		689	SHERWOOD

REF.	R.O./OEM	PAG	REF.	R.O./OEM	PAG	REF.	R.O./OEM	PAG			
SHEP1716C	3919899	654	CUMMINS	TEN00492	683	RENAULT	TEN02033	668	ONAN		
SHEP1716C	3922590	654	CUMMINS	TEN00493	683	RENAULT	TEN02040	656	CUMMINS		
SHEP1716C		688	SHERWOOD	TEN00494	683	RENAULT	TEN02040	671	PERKINS		
SHEP1722C	3912139	653	CUMMINS	TEN00495	683	RENAULT	TEN02041	656	CUMMINS		
SHEP1722C	3922589	653	CUMMINS	TEN01801	683	RENAULT	TEN02041	671	PERKINS		
SHEP1722C		654	CUMMINS	TEN01802	683	RENAULT	TEN02042	656	CUMMINS		
SHEP1722C		688	SHERWOOD	TEN01803	683	RENAULT	TEN02042	671	PERKINS		
SHEP1727C	3897194	654	CUMMINS	TEN01804	683	RENAULT	TEN02043	656	CUMMINS		
SHEP1727C		688	SHERWOOD	TEN02000T	671	PERKINS	TEN02043T	656	CUMMINS		
SHEP1730C	3866493	653	CUMMINS	TEN02020	632	CATERPIL.	TEN02043T	671	PERKINS		
SHEP1730C	3897194	653	CUMMINS	TEN02021	6L2283	632	CATERPIL.	TEN02044	68241	656	CUMMINS
SHEP1730C		654	CUMMINS	TEN02021/1	116-7011	632	CATERPIL.	TEN02044T	656	CUMMINS	
SHEP1730C		688	SHERWOOD	TEN02021/1T		632	CATERPIL.	TEN02044T	671	PERKINS	
SHEP1732C	113-1109	629	CATERPIL.	TEN02021T		632	CATERPIL.	TEN02044TP	656	CUMMINS	
SHEP1732C	152-8392	629	CATERPIL.	TEN02021TP	6L2282	632	CATERPIL.	TEN02090	683	RENAULT	
SHEP1732C	170-6116	629	CATERPIL.	TEN02022	6L2016	632	CATERPIL.	TEN02090T	683	RENAULT	
SHEP1732C		630	CATERPIL.	TEN02022T		632	CATERPIL.	TEN03500	BP195E	684	VETUS
SHEP1732C		690	SHERWOOD	TEN02023	612289	632	CATERPIL.	TEN03500	SET151	684	VETUS
SHEP176X	7E.4115	629	CATERPIL.	TEN02023T		632	CATERPIL.	TEN03502	BP129	684	VETUS
SHEP176X	9Y-1304	629	CATERPIL.	TEN02023TP		632	CATERPIL.	TEN03502	SET153	684	VETUS
SHEP176X	FP-7E4115	629	CATERPIL.	TEN02024	6L2288	632	CATERPIL.	TEN03503		684	VETUS
SHEP176X		630	CATERPIL.	TEN02024T		632	CATERPIL.	TEN03505	BP1221	684	VETUS
SHEP176X		689	SHERWOOD	TEN02024TP		632	CATERPIL.	TEN03505	SET0148	684	VETUS
SHEP2708X		654	CUMMINS	TEN02025	6L2284	632	CATERPIL.	TEN03506	BP1126	684	VETUS
SHEP2708X		690	SHERWOOD	TEN02026	6L2286	632	CATERPIL.	TEN03506	SET0149	684	VETUS
SHER10870G	11353	687	WESTER.	TEN02026T		632	CATERPIL.	TEN03507	BP1185	684	VETUS
SHER10870G		691	SHERWOOD	TEN02026TP		632	CATERPIL.	TEN03507	SET0150	684	VETUS
SHER30G-1	24102	687	WESTER.	TEN02027	6L2280	632	CATERPIL.	TEN03508	BP1210	684	VETUS
SHER30G-1		688-691	SHERWOOD	TEN02027T		632	CATERPIL.	TEN03508	SET0152	684	VETUS
SHER991		689	SHERWOOD	TEN02027TP	6L2279	632	CATERPIL.	TEN03509	BP195	684	VETUS
SHERPBC	NA001175	670	PERKINS	TEN02028	7E5076	632	CATERPIL.	TEN03510	ZINK15SC	684	VETUS
SHERPBC		690	SHERWOOD	TEN02028T		632	CATERPIL.	TEN03511	ZINK25SC	684	VETUS
TEN00220	ZINK15C	685	VETUS	TEN02028TP		632	CATERPIL.				
TEN00221	ZINK25C	685	VETUS	TEN02029	642281	632	CATERPIL.				
TEN00222		685	VETUS	TEN02029bis	6L3104	632	CATERPIL.				
TEN00223	ZINK35C	685	VETUS	TEN02029BIS/T		632	CATERPIL.				
TEN00400SOLE/1	40030092	683	SOLE D	TEN02029T		632	CATERPIL.				
TEN00400SOLE/2	50035092	683	SOLE D	TEN02029TP	6L2279G	632	CATERPIL.				
TEN00400SOLE/3	40045092	683	SOLE D	TEN02030		668	ONAN				
TEN00400SOLE/4	40050092	683	SOLE D	TEN02031		668	ONAN				
TEN00490		683	RENAULT	TEN02031TP		668	ONAN				
TEN00491		683	RENAULT	TEN02032		668	ONAN				

**R.O. / OEM --> REF**

R.O./OEM	REF.	PAG	R.O./OEM	REF.	PAG	R.O./OEM	REF.	PAG		
BORG-W	100-238-002	628	CATERPIL.	3N8449	CEF500179GX	630	CRUSAD.	20318	PH600-0005	642
BORG-W	1004-650-001	628	CATERPIL.	3N8449	JAB18786-0001	630	CRUSAD.	22212	CEF500103T	643
BORG-W	1004-650-002	628	CATERPIL.	3N8449	SHE22000K	630	CRUSAD.	30103	PH600-0002	642
BORG-W	1004-650-006	628	CATERPIL.	4L8470	CEF500145T	630	CRUSAD.	30266	FEL17040	638
BORG-W	1004-650-007	628	CATERPIL.	4L8470	JOH09-814B	630	CRUSAD.	31136	FEL17042	638
BORG-W	1004-650-008	628	CATERPIL.	4L8470	REC875697	630	CRUSAD.	31137	FEL17048	638
BORG-W	1308-410-001	628	CATERPIL.	4P-7168	SHEP1710C	629	CRUSAD.	33393	FEL17310	639
BORG-W	2001-238-001	628	CATERPIL.	5N9357	SHE5N9357	630	CRUSAD.	33408	FEL17010	638
BORG-W	A4867HA	628	CATERPIL.	5N9360	CEF500135	630	CRUSAD.	33628	REC805298A1	646
CATERPIL.	7E-3268	629	CATERPIL.	5N9360	JOH09-819B	630	CRUSAD.	37061	REC17177A1	649
CATERPIL.	612289	632	CATERPIL.	5N9360	REC21730344	630	CRUSAD.	37068	REC1463-9382	651
CATERPIL.	642281	632	CATERPIL.	6L2016	CM6L2016	632	CRUSAD.	38070	REC3854548	648
CATERPIL.	796351	631	CATERPIL.	6L2016	TEN02022	632	CRUSAD.	38071	REC3854549	649
CATERPIL.	1095324	630	CATERPIL.	6L2279	TEN02027TP	632	CRUSAD.	40050	SHEP1014	643
CATERPIL.	1095324	630	CATERPIL.	6L2279G	TEN02029TP	632	CRUSAD.	40057	SHE12859	643
CATERPIL.	1095327	630	CATERPIL.	6L2280	CME1	632	CRUSAD.	40070	REC3860703	643
CATERPIL.	1095327	630	CATERPIL.	6L2280	TEN02027	632	CRUSAD.	41052	REC835702	647
CATERPIL.	1230492	630	CATERPIL.	6L2282	TEN02021TP	632	CRUSAD.	41057	REC33662	648
CATERPIL.	1230492	630	CATERPIL.	6L2283	CM6L2283	632	CRUSAD.	41058	REC8M6001219	648
CATERPIL.	1237985	630	CATERPIL.	6L2283	TEN02021	632	CRUSAD.	41059	REC834975	648
CATERPIL.	1237985	630	CATERPIL.	6L2284	CME8D	632	CRUSAD.	41069	REC392-9086T	647
CATERPIL.	7E0321	630	CATERPIL.	6L2284	TEN02025	632	CRUSAD.	41074	REC3853801	648
CATERPIL.	7E0321	630	CATERPIL.	6L2285	CME-8	632	CRUSAD.	41076	REC392-9766	647
CATERPIL.	7E5076	632	CATERPIL.	6L2286	TEN02026	632	CRUSAD.	41089	REC3853801	648
CATERPIL.	113-1109	629	CATERPIL.	6L2288	CM6L2288	632	CRUSAD.	42090	ARC50137	652
CATERPIL.	116-7011	632	CATERPIL.	6L2288	TEN02024	632	CRUSAD.	42090	PH140-0022	652
CATERPIL.	123-0471	629	CATERPIL.	6L3104	TEN02029bis	632	CRUSAD.	42091	PH140-0022-CCW	652
CATERPIL.	128000-5720	631	CATERPIL.	7C3286	CEF500114T	630	CRUSAD.	45303	REC1397-2060	646
CATERPIL.	147-7850	630	CATERPIL.	7C3286	JAB17937-0001-P	630	CRUSAD.	45334	REC823426A1	645
CATERPIL.	152-8392	629	CATERPIL.	7C3613	REC7C3613	629	CRUSAD.	47002	REC3850397	647
CATERPIL.	16.50-00250	632	CATERPIL.	7C3614	REC7C3614	630	CRUSAD.	47032	REC805226A1	647
CATERPIL.	163-3361	631	CATERPIL.	7E.4115	SHEP176X	629	CRUSAD.	47033	REC3855194	647
CATERPIL.	170-6116	629	CATERPIL.	7E0321	CEF500164T	630	CRUSAD.	51080	REC1463-9382	651
CATERPIL.	196-8895	629-630	CATERPIL.	8N2250	REC8N2250	629	CRUSAD.	67859	PH600-0002	642
CATERPIL.	197-1328	629	CATERPIL.	9Y-1304	SHEP176X	629	CRUSAD.	91351	FEL17930	639
CATERPIL.	1L4774	630	CATERPIL.	FP-7E4115	SHEP176X	629	CRUSAD.	91606	REC982230	644
CATERPIL.	1L4774	630	CRUSAD.	12526	REC33706	648	CRUSAD.	96120	HOT20775-MK	639
CATERPIL.	1L4774	630	CRUSAD.	12528	REC33708	648	CRUSAD.	96120	HOT20925	639
CATERPIL.	1R-0658	631	CRUSAD.	12530	REC8M6001217	648	CRUSAD.	96120	OSC775-MK	639
CATERPIL.	1R-0714	631	CRUSAD.	12531	REC841243	648	CRUSAD.	96121	HOT20775-MK	639
CATERPIL.	1W5664	630	CRUSAD.	12532	REC12532	647	CRUSAD.	96121	HOT20926	639
CATERPIL.	1W5664	630	CRUSAD.	17670	PH600-0002	642	CRUSAD.	96121	OSC775-MK	639
CATERPIL.	1W5664	630	CRUSAD.	20117	REC391-5090	648	CRUSAD.	96216	REC96216	642
CATERPIL.	1W6586	629	CRUSAD.	20129	REC27-14250	639	CRUSAD.	96306	REC27-33395	639
CATERPIL.	212-7264	630	CRUSAD.	20222	REC982209	647	CRUSAD.	96319	BACR-29-96319	644
CATERPIL.	3N1906	630	CRUSAD.	20223	REC9822502	648	CRUSAD.	96358	REC76270T	644
CATERPIL.	3N1906	630	CRUSAD.	20292	SHE4257	643	CRUSAD.	96560	HOT20934	641
CATERPIL.	3N1906	630	CRUSAD.	20300	CEF500120T	643	CRUSAD.	96562	REC96562	641
CATERPIL.	3N4851	630	CRUSAD.	20300	REC10615K	643	CRUSAD.	97114	HOT20799-MK	639
CATERPIL.	3N4859	630	CRUSAD.	20300	SHE10615K	643	CRUSAD.	97114	HOT20929	639
CATERPIL.	3N4859	630	CRUSAD.	20309	SHE10927	643	CRUSAD.	97115	HOT20799-MK	639
CATERPIL.	3N5895	630	CRUSAD.	20310	CEF500120T	643	CRUSAD.	97115	HOT20933	639
CATERPIL.	3N5895	630	CRUSAD.	20310	REC10615K	643	CRUSAD.	97169	HOT20916	641
CATERPIL.	3N5895	630	CRUSAD.	20310	SHE10615K	643	CRUSAD.	97179	SHEE35	643



	R.O./OEM	REF.	PAG		R.O./OEM	REF.	PAG		R.O./OEM	REF.	PAG
CRUSAD.	97214	REC85785A2	646	CUMMINS	3916854	PH150-0008	655	DETROIT D	23501083	DJG0816	657
CRUSAD.	97361	REC97361	644	CUMMINS	3919899	SHEP1716C	654	DETROIT D	23501769	DJG0815	657
CRUSAD.	97386	HOT20918	641	CUMMINS	3922122	REC3922122	653	DETROIT D	23502086	CEF500153	658
CRUSAD.	97387	OSC7387	642	CUMMINS	3922589	DJC0819	653-654	DETROIT D	23502086	JAB18786-0001	658
CRUSAD.	97498	REC27-99757	639	CUMMINS	3922589	DJC2701	653-654	DETROIT D	23502086	REC18786-0001	657-658
CRUSAD.	97595	REC85785A2	646	CUMMINS	3922589	SHEG2603X	654	DETROIT D	23507475	REC8923363	657
CRUSAD.	97624	OSC7624	642	CUMMINS	3922589	SHEP1722C	653	DETROIT D	23507476	REC8923363	657
CRUSAD.	97686	FEL17920	639	CUMMINS	3922590	SHEP1716C	654	DETROIT D	23507477	REC8923363	657
CRUSAD.	97752	HOT20925	639	CUMMINS	3925236	CEF500164T	655	DETROIT D	23507971	DJG0816	657
CRUSAD.	97753	HOT20926	639	CUMMINS	3925236	REC17000K	655	DETROIT D	23507972	DJG0815	657
CRUSAD.	97772	HOT20927	641	CUMMINS	3925236	SHE17000K	655	DETROIT D	23507973	REC8923363	657
CRUSAD.	97895	REC8M0091470	644	CUMMINS	3967246	SHEG2603X	654	DETROIT D	23525200	REC23535447	657
CRUSAD.	97924	HOT20928	641	CUMMINS	3972366	CEF500183G	655	DETROIT D	23535477	REC23535447	657
CRUSAD.	97992	HOT20799-MK	639	CUMMINS	3972366	SHE26000K	654-655	DETROIT D	17540-0001	REC23535447	657
CRUSAD.	97992	HOT20929	639	CUMMINS	3974456	CEF500181G	655	DETROIT D	17540-0201	REC23535447	657
CRUSAD.	97993	HOT20799-MK	639	CUMMINS	3974456	REC27000K	655	FILTR	861014	RAC2010TM-OR	703
CRUSAD.	97993	HOT20933	639	CUMMINS	3974456	SHE27000K	654-655	FILTR	889419	RAC2020PM-OR	703
CRUSAD.	98041	REC35-8M0061975	644	CUMMINS	4019403	CEF500182G	655	FILTR	889419	RAC2040PM-OR	703
CRUSAD.	98068	HOT20934	641	CUMMINS	4019403	REC18000K	655	FILTR	889421	RAC2040SM-OR	703
CRUSAD.	98125	HOT20982	640	CUMMINS	4019403	SHE18000K	655	FILTR	889425	RAC2020SM-OR	703
CRUSAD.	98126	HOT20938	640	CUMMINS	4019951	REC3922122	653	FILTR	1147147	RAC2010SM-OR	703
CRUSAD.	98128	HOT30984	640	CUMMINS	4020066	REC3922122	653	FILTR	3581760	RAC2010PM-OR	703
CRUSAD.	98243	REC98243	640	CUMMINS	4929178	SHEG2903X	654	FILTR	3838852	RAC2040TM-OR	703
CRUSAD.	107399	PH140-0013	652	CUMMINS	4933743	CEF500182G	655	FILTR	3838854	RAC2020TM-OR	703
CRUSAD.	201104	REC35-06003	645	CUMMINS	4933743	REC18000K	655	HURT	879194241	REC016940	658
CRUSAD.	201104	REC3850559	645	CUMMINS	4933743	SHE18000K	655	HURT	8791014241	REC016940	658
CRUSAD.	700425	REC8M0068784	646	CUMMINS	5260393	SHEG2903X	654	HURT	0994-000	HOT20997	659
CRUSAD.	700427	REC97258A1	646	CUMMINS	39127684	SHEGC5	654	HURT	35-813405	REC016940	658
CRUSAD.	705787	REC33662	648	CUMMINS	854179001	SHEP1016	654	HURT	35-813405A1	REC016940	658
CRUSAD.	811573	PH600-0002	642	CUMMINS	879312023	SHEP1016	654	HURT	35-815419	REC016940	658
CRUSAD.	981650	REC3855276	644	CUMMINS	3604654RX	REC3604654RX	655	HURT	53-2009	HGE2018	659
CRUSAD.	982063	REC62092T	644	CUMMINS	8M0084523	REC882571	656	HURT	53-2009	HOT20907	659
CRUSAD.	1003026	CEF500103T	643	CHRIS-C	41057	REC33662	636	HURT	53-2018	HGE2018	659
CRUSAD.	1003026	REC3854286	643	CHRIS-C	42090	ARC50137	638	HURT	53-2018	HOT20907	659
CRUSAD.	1003026	SHE09959K	643	CHRIS-C	45334	REC823426A1	635	HURT	53-2027-T	HGE2027	659
CRUSAD.	1003062	CEF500103T	643	CHRIS-C	1869704	REC64851	636	HURT	53-2800	HOT20998	659
CRUSAD.	1003318	REC841243	648	CHRIS-C	16.50-00074	REC27-34213	634	HURT	F19608751	REC016940	658
CRUSAD.	1109482	PH140-0015	652	CHRIS-C	16.50-00078	REC27-34897	633	HURT	FFF001138	REC016940	658
CRUSAD.	1109484	PH140-0022	652	CHRIS-C	16.50-00162	REC27-344861	637	INDMAR	229678	REC229678	662
CRUSAD.	1109485	PH140-0022-CCW	652	CHRIS-C	16.50-00259	FEL17046	632	INDMAR	252898	REC252898	662
CRUSAD.	1109486	PH140-0013	652	CHRIS-C	16.50-005756	REC27-34898	634	INDMAR	260085	CME0	662
CRUSAD.	3000121	REC393-4988	647	CHRIS-C	16.61-0042	PH140-0013	638	INDMAR	267928	CME0	662
CRUSAD.	3000122	REC65864	649	CHRIS-C	16.61-0043	PH140-0013	638	INDMAR	279449	REC502900	662
CRUSAD.	3000124	REC58033	648	CHRIS-C	16.69-00039	REC391-5090	636	INDMAR	359771	REC834337	662
CRUSAD.	3854161	REC3854161	651	CHRIS-C	16.69-00040	REC8M6001217	636	INDMAR	573001	PH140-0022	661
CRUSAD.	3854261	REC3854261	649	CHRIS-C	16.69-00042	REC841243	636	INDMAR	575010	PH300-0032	661
CRUSAD.	7057500	FEL17030	638	CHRIS-C	16.69-00049	REC34235T	636	INDMAR	575011	PH300-0041	661
CRUSAD.	7142520	PH600-0005	642	CHRIS-C	16.69-00050	REC33662	636	INDMAR	685011	REC3860703	660
CRUSAD.	7243110	REC3854003	650	CHRIS-C	16.69-00051	REC58217	636	INDMAR	751007	REC8M6001219	660
CRUSAD.	7243200	REC3854002	651	CHRIS-C	16.69-00052	REC393-9459Q1	635	INDMAR	755017	REC33662	660
CRUSAD.	9000888	PH140-0022-CCW	652	CHRIS-C	16.69-00100	REC12532	635	KOHLER	229826	CEF500165	663
CRUSAD.	9002514	REC35-06007	645	CHRIS-C	16.69-00148	REC982209	635	KOHLER	229826	REC09000K	663
CRUSAD.	19010615	PH140-0022-CCW	652	CHRIS-C	16.69-00149	REC89825302	636	KOHLER	229826	SHE09000K	663
CRUSAD.	19010617	PH140-0022	652	CHRIS-C	16.80-18346	SHEG30-2B	633	KOHLER	229955	CEF500129	663
CRUSAD.	R061017	CEF500120T	643	CHRIS-C	16.80-90047	SHE10077K	633	KOHLER	229955	REC22779-0001	663
CRUSAD.	R061017	REC10615K	643	CHRIS-C	16.80-90131	SHE10615K	633	KOHLER	246489	SHEG906	663
CRUSAD.	R061017	SHE10615K	643	CHRIS-C	16.81-06536	REC35-06007	634	KOHLER	250872	REC22779-0001	663
CRUSAD.	RA107039E	REC805222A1	650	CHRIS-C	16.81-08746	REC35-06003	634	KOHLER	267373	SHEG906	663
CRUSAD.	RA122008	PH140-0022	652	CHRIS-C	1650-05602	BACC47-1650-06022	633	KOHLER	344085	SHEG907P	663
CRUSAD.	RA122009	PH140-0022-CCW	652	CHRIS-C	1650-05944	OSC0959	633	KOHLER	344089	SHEG906	663
CRUSAD.	RA122015	PH140-0017-D	652	CHRIS-C	18-5399	REC835702	635	KOHLER	344371	SHEG907P	663
CUMMINS	68241	TEN02044	656	CHRIS-C	20-08288	BACC-20-08288	633	KOHLER	132-0275	SHEG8001	663
CUMMINS	882571	REC882571	656	CHRIS-C	20-08289	BACC-20-08289	633	KOHLER	GM46936	SHEG910P	663
CUMMINS	3010336	DJC004	653	CHRIS-C	F16900165	REC12532	635	KOHLER	GM58527	REC29350-1001	663
CUMMINS	3010336	DJC0820	653	DETROIT D	7260	REC5145578	657	MAN	50.06506.0089	CEF500145T	664
CUMMINS	3010336	SHEM71	653	DETROIT D	17030	REC5145578	657	MAN	50.06506.0089	JOH09-814B	664
CUMMINS	3278137	DJC004	653	DETROIT D	17050	REC5145578	657	MAN	50.06506.0089	REC875697	664
CUMMINS	3278137	DJC0820	653	DETROIT D	18760	REC8923363	657	MAN	50.06506.0091	CEF500106GT	664
CUMMINS	3278137	SHEM71	653	DETROIT D	18780	REC8927296	657	MAN	50.06506.0091	JOH09-1028B	664
CUMMINS	3349198	CEF500167	655	DETROIT D	18789	REC8927296	657	MAN	50.06506.0091	REC3841697	664
CUMMINS	3349198	REC15000K	655	DETROIT D	5106016	DJG0815	657	MAN	51.06506.0103	CEF500162G	664
CUMMINS	3349198	SHE15000K	655	DETROIT D	5107480	DJG0816	657	MAN	51.06506.0103	JOH09-821B	664
CUMMINS	3349392	SHEG2903X	654	DETROIT D	5115396	DJG0816	657	MAN	51.06506.0106	CEF500186T	664
CUMMINS	3802444	CEF500164T	655	DETROIT D	5122599	DJG0815	657	MAN	51.06506.0106	JOH09-820B	664
CUMMINS	3802444	REC17000K	655	DETROIT D	5145576	REC5145578	657	MAN	51.06506.0127	JOH09-842B	664
CUMMINS	3802444	SHE17000K	655	DETROIT D	5145577	REC5145578	657	NANNI D	434013	CEF500121GX	664
CUMMINS	3866493	DJC1730	653	DETROIT D	5145578	REC5145578	657	NANNI D	434013	JOH09-808B	664
CUMMINS	3866493	SHEP1730C	653	DETROIT D	5186250	DJG0816	657	NANNI D	434013	REC3586496	664
CUMMINS	3897194	DJC1730	653-654	DETROIT D	5193553	CEF500105T	658	NANNI D	434014	CEF500101X	664
CUMMINS	3897194	SHEP1727C	654	DETROIT D	5193553	JOH09-1029B	658	NANNI D	434014	JOH09-810B	664
CUMMINS	3897194	SHEP1730C	653	DETROIT D	5193553	REC836-0001	658	NANNI D	434014	REC653-0001	664
CUMMINS	3897337	CEF500164T	655	DETROIT D	5193602	CEF500106GT	658	NANNI D	48200932	PH300-0027-OE	664
CUMMINS	3897337	REC17000K	655	DETROIT D	5193602	JOH09-1028B	658	ONAN	1220185	REC1220185	665
CUMMINS	3897337	SHE17000K	655	DETROIT D	5193602	REC3841697	658	ONAN	1220602	REC1220602	666
CUMMINS	3904445	PH150-0008	655	DETROIT D	5196168	CEF500145T	658	ONAN	1220810	REC1220810	666
CUMMINS	3907458	DJC0820	653	DETROIT D	5196168	JOH09-814B	658	ONAN	1320278	SHEL10B	667
CUMMINS	3907458	SHEM71	653	DETROIT D	5196168	REC875697	658	ONAN	1491754	REC1491754	665
CUMMINS	3908220	CEF500120T	655	DETROIT D	5196629	CEF500106GT	658	ONAN	1491758	REC1491758	665
CUMMINS	3908220	REC10615K	655	DETROIT D	5196629	JOH09-1028B	658	ONAN	1492250	REC1492250I	665
CUMMINS	3908220	SHE10615K	655	DETROIT D	5196629	REC3841697	658	ONAN	1492251	REC1492251II	665
CUMMINS	3912019	DJC0820	653	DETROIT D	5197221	REC5197221	657	ONAN	1855835	REC1855835	666
CUMMINS	3912019	SHEM71	653	DETROIT D	5199148	CEF500106GT	658	ONAN	08-21-1201	CEF500107T	668
CUMMINS	3912139	DJC0819	653	DETROIT D	5199148	JOH09-1028B	658	ONAN	08-21-1201	JOH09-1027B	668
CUMMINS	3912139	SHEP1722C	653	DETROIT D	5199148	REC3841697	658	ONAN	08-21-1201	REC21213660	668
CUMMINS	3912962	DJC0830	653-654	DETROIT D	8923363	REC8923363	657	ONAN	122-0185	REC1220185	665
CUMMINS	3912962	SHEGC1	653-654</								

	R.O./OEM	REF.	PAG		R.O./OEM	REF.	PAG		R.O./OEM	REF.	PAG
ONAN	132-0117	CEF500103T	668	PLEASURE.	R028001	HOT20996	672	VETUS	STM8061	CEF500101X	685
ONAN	132-0117	REC3854286	668	PLEASURE.	R029001	HOT20899	672	VETUS	STM8061	JOH09-810B	685
ONAN	132-0117	SHE09959K	668	PLEASURE.	R029011	HOT20011	672	VETUS	STM8061	REC653-0001	685
ONAN	132-0162	CEF500107T	668	PLEASURE.	R077001	REC35-06007	675	VETUS	ZINK15C	TEN00220	685
ONAN	132-0162	JOH09-1027B	668	PLEASURE.	R077002	REC35-06003	675	VETUS	ZINK15SC	TEN03510	684
ONAN	132-0162	REC21213660	668	PLEASURE.	R084003	REC803149	676	VETUS	ZINK25C	TEN00221	685
ONAN	132-0275	SHEK75B	667	PLEASURE.	R085035	REC32-86036	681	VETUS	ZINK25SC	TEN03511	684
ONAN	132-0278	SHEL10B	667	PLEASURE.	R094020A	REC23-99291	681	VETUS	ZINK35C	TEN00223	685
ONAN	132-0292	CEF500120T	668	PLEASURE.	R096081	REC897367	681	WESTER.	11353	SHER10870G	687
ONAN	132-0292	REC10615K	668	PLEASURE.	R096116	REC12-835467Q01	681	WESTER.	11418	CEF500103T	687
ONAN	132-0292	SHE10615K	668	PLEASURE.	R096117	REC90508-ZW1-003	681	WESTER.	11418	REC3854286	687
ONAN	132-0317	CEF500103T	668	PLEASURE.	R103001	REC89825302	677	WESTER.	11418	SHE09959K	687
ONAN	132-0317	REC3854286	668	PLEASURE.	R103003	REC834975	677	WESTER.	11764	CEF500166	687
ONAN	132-0317	SHE09959K	668	PLEASURE.	R103004	REC3853801	677	WESTER.	11764	REC10077K	687
ONAN	132-0343	SHEG1010	667	PLEASURE.	R103011	REC898253013	677	WESTER.	11764	SHE10077K	687
ONAN	132-0347	SHEG1010	667	PLEASURE.	R108001	REC982209	676	WESTER.	11885	CME0	686
ONAN	132-0348	CEF500120T	668	PLEASURE.	R114001	REC391-5090	676	WESTER.	11907	CEF500103T	687
ONAN	132-0348	REC10615K	668	PLEASURE.	R114002	REC8M6001219	676	WESTER.	11907	REC3854286	687
ONAN	132-0348	SHE10615K	668	PLEASURE.	R114004	REC391-5090	676	WESTER.	11907	SHE09959K	687
ONAN	132-0349	CEF500120T	668	PLEASURE.	R115001	REC8M6001217	677	WESTER.	13930	CEF500120T	687
ONAN	132-0349	REC10615K	668	PLEASURE.	R115002	REC33662	677	WESTER.	13930	REC10615K	687
ONAN	132-0349	SHE10615K	668	PLEASURE.	R117001	REC1463-9382	679	WESTER.	13930	SHE10615K	687
ONAN	132-0356	SHEG1010	667	PLEASURE.	R117012	REC3861267	679	WESTER.	24102	SHER30G-1	687
ONAN	132-0358	SHEG702	666	PLEASURE.	R130001	PH375-0027	681	WESTER.	30594	ARC86050	686
ONAN	132-0375	CEF500166	668	PLEASURE.	RA057004	PH600-0006	673	WESTER.	33100	CEF500166	687
ONAN	132-0375	REC10077K	668	PLEASURE.	RA057018	PH600-0005	673	WESTER.	33100	REC10077K	687
ONAN	132-0375	SHE10077K	668	PLEASURE.	RA057019	PH600-0002	673	WESTER.	33100	SHE10077K	687
ONAN	132-0395	SHEG8002	667	PLEASURE.	RA057023	REC3860703	673	WESTER.	33104	CEF500103T	687
ONAN	132-0413	SHEG1010	667	PLEASURE.	RA057026	REC3860703	673	WESTER.	33104	REC3854286	687
ONAN	132-0415	CEF500190G	668	PLEASURE.	RA097002	PH300-0013	680	WESTER.	33104	SHE09959K	687
ONAN	132-0415	REC08000K	667-668	PLEASURE.	RA097003	PH300-0013	680	WESTER.	33486	PH140-0022	686
ONAN	132-0415	SHE08000K	667-668	PLEASURE.	RA097006	PH300-0013	680	WESTER.	33636	CEF500101X	687
ONAN	132-0430	SHEG8002	667	PLEASURE.	RA097007	PH300-0041	681	WESTER.	33636	JOH09-810B	687
ONAN	132-0459	SHEG702	666	PLEASURE.	RA097007B	PH300-0032	681	WESTER.	33636	REC48080	687
ONAN	132-0464	SHEG1012	667	PLEASURE.	RA097007L	PH300-0032	681	WESTER.	33636	REC653-0001	687
ONAN	132-0859	CEF500100GX	668	PLEASURE.	RA107001	REC392-6316	677	WESTER.	35595	REC35595	686
ONAN	132-0859	JOH09-806B	668	PLEASURE.	RA107039E	REC805222A1	678	WESTER.	36450	REC36450	686
ONAN	132-0859	REC3586494	668	PLEASURE.	RA108002	REC835702	676	WESTER.	36918	REC36918	686
ONAN	135-0278	SHEK75B	667	PLEASURE.	RA108003	REC392-9766	676	WESTER.	37431	CEF500101X	687
ONAN	149-0428	REC149-0428	665	PLEASURE.	RA108009	REC898253T22	676	WESTER.	37431	JOH09-810B	687
ONAN	149-2106	REC149-2106	665	PLEASURE.	RA122001	PH140-0004	680	WESTER.	37431	REC48080	687
ONAN	185-2133	REC185-2133	666	PLEASURE.	RA122008	PH140-0022	679	WESTER.	37431	REC653-0001	687
ONAN	185-5835	REC1855835	666	PLEASURE.	RA122009	PH140-0022-CCW	679	WESTER.	38100	REC38100	686
ONAN	187.0014	REC1870014	666	PLEASURE.	RA57007	SHEG21	673	WESTER.	48080	CEF500101X	687
PERKINS	89058	BAPE-1-6354	669	PLEASURE.	RK122014	PH140-0004	680	WESTER.	48080	JOH09-810B	687
PERKINS	460024	CEF500114T	671	PLEASURE.	RM0007	REC3852455	672	WESTER.	48080	REC48080	687
PERKINS	460024	JAB17937-0001-P	671	PLEASURE.	RM0032	FEL17060	672	WESTER.	48080	REC653-0001	687
PERKINS	460024	REC17937-0001	671	PLEASURE.	RN0067	REC1396-4148	675	WESTER.	302875	CEF500165	687
PERKINS	460027	CEF500105T	671	PLEASURE.	RN0116	REC1396-4656	675	WESTER.	302875	REC09000K	687
PERKINS	460027	CEF500145T	671	PLEASURE.	RN0116-2	REC1396-4656	675	WESTER.	302875	SHE09000K	687
PERKINS	460027	JOH09-1029B	671	PLEASURE.	RN0118	REC1396-5238	675				
PERKINS	460027	REC836-0001	671	PLEASURE.	RN0120	REC1396-5238	675				
PERKINS	460027	REC875697	671	PLEASURE.	RO200001	REC8M0068784	675				
PERKINS	460038	CEF500107T	671	PLEASURE.	RP026002E	REC97361	674				
PERKINS	460038	JOH09-1027B	671	PLEASURE.	RP061015	SHE09959K	674				
PERKINS	460038	REC21213660	671	PLEASURE.	RP061017	SHE10615K	674				
PERKINS	2654347	REC35-816168	669	RENAULT	48300006	CEF500128	682				
PERKINS	2654407	REC35-816168	669	RENAULT	48300007	CEF500128	682				
PERKINS	2656017	REC3581078	669	RENAULT	48300008	CEF500122T	682				
PERKINS	24880031	CEF500114T	671	RENAULT	48300037	CEF500127	682				
PERKINS	24880031	JAB17937-0001-P	671	RENAULT	48300055	CEF500127	682				
PERKINS	24880031	REC17937-0001	671	RENAULT	RC320D	CEF500106GT	682				
PERKINS	24880178	CEF500103T	671	RENAULT	RC320D	JOH09-1028B	682				
PERKINS	24880178	REC3854286	671	RENAULT	RC320D	REC3841697	682				
PERKINS	24880178	SHE09959K	671	SHERWOOD	17000	SHE25105	696				
PERKINS	24880190	CEF500107T	671	SHERWOOD	18000	SHE25105	696				
PERKINS	24880190	JOH09-1027B	671	SHERWOOD	22000	SHE25105	696				
PERKINS	24880190	REC21213660	671	SHERWOOD	26000	SHE25105	696				
PERKINS	24880194	CEF500116GX	671	SHERWOOD	27000	SHE25106	696				
PERKINS	24880194	JOH09-1026B	671	SOLE D	40030092	TEN00400SOLE/1	683				
PERKINS	24880194	REC3593659	671	SOLE D	40045092	TEN00400SOLE/3	683				
PERKINS	24880272	CEF500100GX	671	SOLE D	40050092	TEN00400SOLE/4	683				
PERKINS	24880272	JOH09-806B	671	SOLE D	50035092	TEN00400SOLE/2	683				
PERKINS	24880272	REC3586494	671	SOLE D	312.11.008	CEF500123X	683				
PERKINS	135616660	MAR906	669	SOLE D	321.11.008	CEF500131X	683				
PERKINS	135616660	RM861906	669	SOLE D	347.11.008	CEF500106GT	683				
PERKINS	185086600	REC21323043	671	SOLE D	347.11.008	JOH09-1028B	683				
PERKINS	185086610	REC21302969	671	SOLE D	347.11.008	REC3841697	683				
PERKINS	185086620	REC21302969	671	SOLE D	351.11.008	CEF500107T	683				
PERKINS	3776F024	MAR345	669	SOLE D	351.11.008	JOH09-1027B	683				
PERKINS	M20	REC29350-1001	670	SOLE D	351.11.008	REC21213660	683				
PERKINS	NA001175	REC09140	670	VETUS	BP1126	TEN03506	684				
PERKINS	NA001175	SHERPBC	670	VETUS	BP1185	TEN03507	684				
PERKINS	NA003335	SHEG65	670	VETUS	BP1210	TEN03508	684				
PERKINS	NA005576	SHEH5	670	VETUS	BP1221	TEN03505	684				
PERKINS	NA900010	CEF500103T	671	VETUS	BP129	TEN03502	684				
PERKINS	NA900010	REC3854286	671	VETUS	BP195	TEN03509	684				
PERKINS	NA900010	SHE09959K	671	VETUS	BP195E	TEN03500	684				
PERKINS	NA900012	CEF500120T	671	VETUS	IMP00101	CEF500129	685				
PERKINS	NA900012	REC10615K	671	VETUS	IMP00101	REC22779-0001	685				
PERKINS	NA900012	SHE10615K	671	VETUS	IMP00201	JOH09-1027B	685				
PLEASURE.	40050	SHEP1014	674	VETUS	IMP00201	REC21213660	685				
PLEASURE.	987811	PH140-0004	680	VETUS	IMP00301	CEF500106GT	685				
PLEASURE.	3705042	REC27-34213	674	VETUS	IMP00301	JOH09-1028B	685				
PLEASURE.	6269577	FEL17030	672	VETUS	IMP00301	REC3841697	685				
PLEASURE.	9000888	PH140-0022	679	VETUS	IMP00701	CEF500146X	685				
PLEASURE.	CHV-47-000	REC27-33395	672	VETUS	SET0148	TEN03505	684				
PLEASURE.	R017066	REC90301-ZW1-003	681	VETUS	SET0149	TEN03506	684				
PLEASURE.	R020027	REC22024631	675	VETUS	SET0150	TEN03507	684				
PLEASURE.	R020035A	REC892615002	676	VETUS	SET0152	TEN03508	684				
PLEASURE.	R026002E	REC8M0089715	674	VETUS	SET151	TEN03500	684				
				VETUS	SET153	TEN03502	684				

**GARANTÍA LIMITADA DE RECAMBIOS MARINOS, S.L.**  
**LIMITED WARRANTY OF THE RECAMBIOS MARINOS, S.L. PRODUCTS**  
**GARANZIA LIMITATA DI RECAMBIOS MARINOS, S.L.**

## GARANTÍA LIMITADA DE RECAMBIOS MARINOS, S.L.

**1.** Los productos suministrados por Recambios Marinos están garantizados por defectos en el material o fabricación por un periodo de:

**2 años desde la fecha de compra para productos NUEVOS  
1 año para los RECONSTRUIDOS.**

Los productos utilizados con fines comerciales, de alquiler o uso profesional, están garantizados por un periodo de **90 días**.

En cualquier caso será imprescindible la presentación de la factura de compra.

**2.** Recambios Marinos no cubre en garantía y queda al margen de cualquier error de instalación que pudiera ocasionar el concesionario, servicio técnico, mecánico o cliente final. Esta garantía se refiere únicamente a defectos de fabricación y excluye los siguientes casos:

- modificación, desmontaje de las piezas
- ajustes
- desgaste normal
- daños producidos por accidente
- instalación defectuosa o mala manipulación
- mal uso, negligencia
- falta de mantenimiento
- uso de algún accesorio o pieza no vendida por Recambios Marinos
- funcionamiento con gasolina, aceites o lubricantes que no son adecuados para ese tipo de producto (no recomendado).

La responsabilidad de garantía de Recambios Marinos quedará anulada si la pieza está dañada por:

- inundación
- fuego
- tormenta
- cualquier otro elemento climatológico natural
- cuando el número de modelo u otra identificación haya sido alterada, modificada o borrada.

**3.** Recambios Marinos no será responsable de ningún cargo por:

- mano de obra
- combustible
- servicios de grúa o rampa
- remolcado
- desplazamiento
- otros gastos indirectos que resulten por causa del fallo del producto, por un defecto del mismo o por una demora razonable en corregir tal defecto.

Estos conceptos no están cubiertos por esta garantía.

**4.** Recambios Marinos se reserva el derecho de inspeccionar y determinar si la pieza ha fallado por causa de un defecto de fabricación. No desmonte ninguna pieza. La obligación de Recambios Marinos estará limitada a reparar, reemplazar o abonar el producto una vez se haya identificado como defectuoso a su total discreción. También se reserva el derecho de abonar el importe a su precio de compra, antes que reparar o reemplazar el producto o algún componente del mismo.

Las piezas están cubiertas por esta garantía únicamente en su periodo original. Una vez el periodo de garantía ha expirado, la garantía de cualquier pieza reparada o sustituida expira también. Recambios Marinos podrá quedarse las piezas que considere defectuosas.

**5.** Recambios Marinos no garantiza ni se responsabiliza del uso o resultado de utilización del producto en términos de su funcionamiento, fiabilidad, etc. La totalidad del riesgo como resultado y funcionamiento del producto la asume el cliente.

**6.** La responsabilidad por cumplimiento de la garantía, estará limitado al precio de compra pagado por el producto.

**7.** Ningún concesionario de Recambios Marinos, agente o empleado está autorizado a hacer extensión o modificación alguna de esta política de garantías.

**8.** Proceso:

- Se deberá comunicar a Recambios Marinos cualquier defecto de producto que se encuentre dentro del periodo de garantía para obtener inmediatamente el impreso de solicitud de garantía y un número de RGA (expediente de garantía).
- Una vez Recambios Marinos haya recibido la solicitud de garantía y la pieza reclamada con el número de expediente, marcado en el embalaje de la pieza, se procederá a su revisión.
- Si el defecto está cubierto por la garantía, la pieza será reparada o reemplazada.
- Si se precisa reparación, deberán enviar a Recambios Marinos el producto a portes pagados con la prueba de compra.
- Cuando la pieza esté reparada, se devolverá por el sistema de envío determinado por Recambios Marinos.

Puede contactar con el Servicio Técnico de Recambios Marinos en: **garantias@recambiosmarinos.es**.

**9.** Esta garantía comprende única y exclusivamente la garantía relacionada con el producto que le ha suministrado Recambios Marinos. Otras garantías o compromisos efectuados por cualquier persona no autorizada, no son vinculantes para Recambios Marinos a menos que se haya autorizado previamente por escrito.



### GARANTÍA LIMITADA

	Embarcaciones de recreo	Embarcaciones comerciales o charters
LONG BLOCKS		
SHORT BLOCKS	12 Meses (Partes y mano de obra)	6 meses (Partes y mano de obra)
PERFORMANCE LONG BLOCKS		NO HAY GARANTÍA

Recambios Marinos decidirá si reemplaza las partes defectuosas o el motor completo. Todas las reparaciones las efectuará a su cargo el vendedor/distribuidor incluyendo la mano de obra aplicable según la Política de Mano de Obra detallada más adelante. **ES IMPRESCINDIBLE LA AUTORIZACIÓN DE RECAMBIOS MARINOS ANTES DE COMENZAR ALGUNA REPARACIÓN EN GARANTÍA.** Puede contactar con Recambios Marinos para conseguir el número de autorización. Las reparaciones o reemplazos de motor no alargan la validez de esta Garantía Limitada.

#### TRANSFERIBLE

Esta garantía es transferible y no está limitada al último comprador/propietario en el momento de la venta.

#### MANO DE OBRA

Recambios Marinos pagará la mano de obra sólo en reparaciones efectuadas en establecimientos autorizados. Recambios Marinos no se hace responsable de pagar mano de obra en reparaciones efectuadas por terceros que no estén certificados como mecánicos navales (Certificado de titulación correspondiente). En ningún caso, el total que se abonará por mano de obra superará los 400€ para barcos de hasta 20 pies, ó 470€ para barcos cabinados de 21 pies o superiores.

#### OBLIGACIONES DEL COMPRADOR

Pasadas 10 horas de la puesta en marcha del motor, el último comprador/propietario debe asegurarse de que un establecimiento autorizado y cualificado revisa el motor. Esta revisión debe incluir como mínimo: el ajuste de levas (si procede), ajuste de válvulas, ajustes del distribuidor y carburador, reapriete de los tornillos (First

Mate Marine recomienda reapretarlos independientemente del tipo de junta), cambiar el aceite y el filtro de aceite.

Vigile cuidadosamente los niveles de aceite durante las 100 primeras horas de funcionamiento ya que el consumo de aceite podría ser superior durante este periodo. Utilice aceite de motor de calidad con el grado y viscosidad apropiados y que recomienda el fabricante de los motores originales. First Mate Marine recomienda no utilizar aceites sintéticos o no detergentes el uso de los cuales anularía totalmente esta garantía. Una adecuada presión de aceite y lubricación son obligatorias para el buen funcionamiento del motor. Todas las embarcaciones deben estar equipadas con relojes o luces que indiquen la temperatura y presión de aceite del motor. **NO HAGA FUNCIONAR EL MOTOR EN CASO DE DETECTAR UNA PRESIÓN DE ACEITE O TEMPERATURA DEL AGUA INADECUADAS.**

Después de poner el motor en marcha, evite RPM excesivas y mantenga el barco planeando. Adapte las RPM durante las 3 a 5 primeras horas de funcionamiento. Unas RPM demasiado elevadas pueden dañar el motor causando fricción y recalentamiento. Evite largos periodos al ralentí. El calentamiento y fallo del motor debido a falta de lubricación se puede prevenir si se monitoriza a través de los relojes y de las luces de aviso. La negligencia del comprador no puede en ningún caso ser el motivo de los daños ocasionados al motor.

## LIMITACIONES Y EXCLUSIONES

Cualquier otra garantía (incluyendo las que haya extendido el vendedor o que se hayan extendido para un propósito particular), quedan excluidas y ninguna de ellas variará la validez o condiciones de esta garantía facilitada por Recambios Marinos. Asimismo, no existirá ningún acuerdo verbal facilitado por terceras personas, distribuidor o vendedor que modifique los límites de la garantía.

Recambios Marinos no será responsable de:

1. Daños o reparaciones ocasionados a consecuencia de una instalación defectuosa, mal uso del motor, servicio técnico inadecuado, alteraciones o modificaciones no autorizadas.
2. Piezas no suministradas por Recambios Marinos (incluyendo cárter, colectores y tapas, bombas de agua, distribuidor y carburador o sistemas de inyección de combustible) u otras.
3. Daños que resulten de la detonación o preencendido, incluyendo los pistones rotos o fundidos, aros rotos o rayados, culatas o juntas de culata dañadas o rayadas, ralladuras en la camisa del cilindro o en la cabeza de los pistones.
4. Daños que resulten de una prelubricación inadecuada del motor antes de su puesta en marcha.

No se podrán reclamar otros gastos (directos o indirectos) como pérdida de beneficios, ventas perdidas, daños a otra persona o propiedad, remolque del barco, aceites, lubricantes, filtros, anti-congelantes, juntas, gastos de envío, etc.

## LIMITED WARRANTY OF THE RECAMBIOS MARINOS, S.L. PRODUCTS

1. The products of Recambios Marinos are warranted to be free from manufacturing defects for a period of:

**2 years from the date of purchase for the NEW products  
1 year for the REBUILT products.**

Products used for commercial, rental or income producing activity are warranted for: **90 days.**

In any case it will be essential to present the purchase invoice.

2. Recambios Marinos not warrant or make any representations in respect to installation errors made by a servicing dealer, servicing mechanic or the individual. This warranty applies to manufacturing defect only, it does not apply to the following:

- alteration, removal of parts,
- adjustments, tune-up
- damages due to accident
- improper installation or service
- misuse, neglect
- lack of maintenance
- use of any accessory or part not sold by Recambios Marinos
- operation with fuels, oils or lubricants which are not suitable for use with the product.

Recambios Marinos liability under this warranty shall be terminated on any part damaged by:

- flood
- fire
- storm
- other natural acts
- where the model number and other identification has been altered, defaced or removed.

3. Recambios Marinos will not be liable for any charges like:

- labor charges
- fuel
- towing
- ramp
- lift
- trips
- special or indirect damages resulting from the product or caused by the defect or reasonable delay in correcting the defect are not covered.

4. Recambios Marinos reserves the right to inspect and determine whether or not any part failed due to a manufacturing defect. Do

not disassemble any parts. Recambios Marinos reserves the right to credit, refund your purchase price for the product rather than repair or replace the product or any part thereof.

Any part is covered only for the original warranty period. Once the warranty on the product has expired, the warranty on any replaced or repaired part also expires. We shall be allowed to keep parts it deems defective under this warranty.

5. Recambios Marinos does not warrant, guarantee or make any representations regarding the use or the results of the use of the product in terms of its correctness, reliability or otherwise. The entire risk as to the result and performance of the product is assumed by customer.

6. The liability to you for actual damages from any cause, will be limited to the purchase price paid for the product.

7. No Recambios Marinos dealer, agent or employee is authorized to make any modification or extension to this warranty.

8. Process:

- You are required to notify Recambios Marinos any defect within the applicable warranty period and immediately obtain a warranty application and a RGA number (warranty claim number).
- Upon we receive the completed warranty application and part claimed under this warranty with the RGA number marked on the shipping and packing of the part, Recambios Marinos will inspect the part for warranty coverage.
- Only when the defect is covered by the warranty will the part be repaired or replaced.
- If warranty service is required, you must deliver your product at your expense, with proof of purchase.
- When the repair is completed, Recambios Marinos will ship back. Shipping methods will be determined by Recambios Marinos.

You can contact with our warranty department through:

**garantias@recambiosmarinos.es.**

9. This warranty compromises the sole and entire warranty pertaining to the product furnished to you by Recambios Marinos. Any other representations or promises by any person are unauthorized and are not binding upon Recambios Marinos unless in writing.

## LIMITED WARRANTY

	Pleasure Craft Boats	Commercial or Charter Boats
LONG BLOCKS		
SHORT BLOCKS	12 Months (Parts & Labor)	6 Months (Parts & Labor)
PERFORMANCE LONG BLOCKS		NO WARRANTY

Recambios Marinos will, at its sole discretion, replace defective parts or a complete engine. All repairs will be made at the seller's or distributor's costs, plus applicable labor pursuant to the labor policy set forth below. **PRIOR AUTHORIZATION IS REQUIRED FROM FIRST MATE MARINE ENGINES BEFORE WARRANTY WORK IS BEGUN.** Call Recambios Marinos for a numbered authorization. Repairs or replacements do not extend this Limited Warranty.

### TRANSFERABLE

This warranty is transferable and is not limited to the ultimate purchaser/owner at the time of sale.

### LABOR POLICY

Recambios Marinos will pay labor claims only to repair facilities it has authorized and will only pay labor claims that the purchaser actually incurs as an out of pocket expense. First Mate Marine will not be liable for or pay any labor claims on Recambios Marinos installed by any third party who is not a certified marine mechanic (Marine Certificate or equivalent) it has authorized to perform repair work and will not pay any labor claims on engines installed in whole or in part by purchaser. In no event shall the total value of this limited warranty whether paid or made in kind, exceed the original distribution price of the engine purchased plus an additional amount of labor cost not to exceed 400€ for all boats 20 foot or shorter, 470€ for cabin cruisers 21 foot or longer.

### OWNER OBLIGATIONS

After 10 hours upon initial startup, ultimate purchaser/owner shall assure that a certified licensed and qualified mechanic authorized by First Mate Marine inspects your engine, which inspection should include, but is not limited to, adjustment of the tappets (if applicable) adjustment of valves, timing and carburetor adjustments, tightening of gasket bolts (First Mate Marine recommends retorquing gasket bolts

regardless of gasket type), and a change of oil and oil filter. Carefully monitor oil levels for the first 100 hours as oil consumption may be higher during this period. Use good quality motor oil of the appropriate grade and viscosity as recommended by the original engine manufacturer. First Mate Marine recommends against the use of synthetic oils or non-detergents oils, the use of which by the purchaser shall void this Limited Warranty. Proper oil pressure and lubrication are mandatory for good engine break-in. All boats should be equipped with gauges or lights to indicate engine temperature and oil pressure. **DO NOT OPERATE BOAT WITH ABNORMAL OIL PRESSURE OR WATER TEMPERATURE.**

After initial startup, avoid excessive RPM and keep boat on plane. Vary RPM range for the first 3 to 5 hours of running time. High engine RPM may damage your new engine through friction and high temperatures. Avoid long periods of idling. Engine overheating and engine failure due to the lack of lubrication can be prevented by adequate monitoring of all gauges or lights and should never in the absence of neglect by the purchaser result in engine damage.

### LIMITATIONS OF WARRANTY AND EXCLUSIONS

All other warranties express or implied, and all implied warranties (including merchantability and fitness for a particular purpose) are hereby excluded and no warranties exist which extend beyond the description in the express limited warranty on the face of this document with regard to any engine or part provided by Recambios Marinos.

No oral statements by any person distributor or salesman may modify or change this limited warranty. No term of any purchase order or other form the purchaser or distributor/seller shall modify or change the limited warranty.

Recambios Marinos shall not be responsible for:

1. Damage or repairs required as a consequence of faulty installation, misapplication, abuse, improper servicing, unauthorized alteration or improper operation.
2. Parts not supplied by Recambios Marinos, (including but not limited to pan, manifolds and covers, water pumps, fuel pumps, distributor and carburetor or fuel injection system), or some else.
3. Damages resulting from detonation or pre-ignition, including but not limited to melted or broken pistons, broken or scored rings, damaged cylinder heads or gaskets, scoring on cylinder walls or piston heads.
4. Damages resulting from improper pre-lubrication prior to startup.

No other remedy (including, but not limited to, any special, direct or indirect, incidental or consequential damages, such as lost profits, lost sales, injury to person or property, towing, oil, lubricants, filters, antifreeze, gasket, shipping and freight, loss of use of vehicle or loss of time, or any other incidental or consequential loss) shall be available to the ultimate purchaser/owner.

## GARANZIA LIMITATA DI RECAMBIOS MARINOS, S.L.

1. I prodotti forniti da Recambios Marinos sono garantiti contro i difetti di materiale o di lavorazione per un periodo di:

**2 anni dalla data di acquisto per prodotti del tutto NUOVI  
1 anno per i RIGENERATI.**

I prodotti utilizzati per finalità commerciali, il noleggio o uso aziendale, sono garantiti per un periodo di: **90 giorni.**

Solo saranno coperti dalla garanzia i clienti che possono fornire la prova di acquisto della Recambios Marinos.

2. Recambios Marinos non copre in garanzia e rimane al margine di eventuali errori di installazione che potrebbero causare il concessionario, il servizio meccanico o il cliente finale. Questa garanzia copre solo i difetti di fabbricazione ed esclude i seguenti casi:

- modifica, smontaggio di parti
- rettifiche
- la normale usura
- danni accidentali
- un'installazione difettosa o uso improprio
- abuso, negligenza
- mancanza di manutenzione
- l'uso di qualsiasi accessori o componenti non venduti dalla Recambios Marinos

- da benzina, olio e lubrificanti che non sono adatti a questo tipo di prodotto (non raccomandato).

La responsabilità di garanzia della Recambios Marinos sarà se l'articolo è danneggiato dalle:

- inondazioni,
- incendi,
- tempeste,
- o elemento naturale climatico,
- o se il numero di modello o altro tipo di identificazione è stato alterato, modificato o cancellato.

3. Recambios Marinos non sarà responsabile di tutte le spese per:

- la manodopera,
- i servizi di carburante,
- gru o rampe,
- traino,
- viaggio,
- altri costi indiretti dovuti a causa di guasto del prodotto, un difetto dello stesso o di un termine ragionevole per correggere questo difetto.

Questi concetti non sono coperti da questa garanzia.

4. Recambios Marinos si riserva il diritto di ispezionare e determinare se la parte si è guastata a causa di un difetto di fabbricazione. Non smontare nessun pezzo. L'obbligo di Recambios Marinos è limitato a riparare, sostituire o rimborsare il prodotto una volta che è stato identificato come difettoso a sua unica discrezione. Si riserva altresì il diritto di pagare il prezzo di acquisto, piuttosto che riparare o sostituire il prodotto o qualsiasi componente. I pezzi sono coperti di garanzia solo per il suo periodo originale. Una volta che il periodo di garanzia è scaduto, la garanzia su tutte le parti soggette a manutenzione automaticamente scade. Recambios Marinos può tenersi i pezzi che consideri difettosi secondo la politica di garanzia.

5. Recambios Marinos non garantisce né si responsabilizza dell'uso o ai risultati di utilizzo del prodotto in termini di prestazioni, affidabilità, ecc. L'intero rischio come risultato e le prestazioni del prodotto, è a carico del cliente.

6. La responsabilità della Recambios Marinos verso il cliente per il compimento della garanzia, sarà limitata al prezzo di acquisto pagato per il prodotto.

7. Nessun rivenditore della Recambios Marinos, agente o dipendente è autorizzato ad apportare qualsiasi modifica o estensione di questa polizza di garanzia.

8. Processo:

- Deve comunicare alla Recambios Marinos qualsiasi difetto di prodotto che si trova dentro del periodo di garanzia alla Recambios Marinos per ottenere immediatamente l'impresso di sollecito di garanzia e un numero di RGA (numero di garanzia).
- Una volta Recambios Marinos ha ricevuto la richiesta di garanzia e il pezzo reclamato con il numero di file RGA e l'imballo originale Recambios Marinos procederà alla sua ispezione.
- Solo se il difetto entra in garanzia, il pezzo verrà riparato o sostituito, a discrezione della Recambios Marinos.
- In caso si richieda la riparazione, bisognerà inviare il prodotto alla Recambios Marinos utilizzando il nostro corriere prepagato con la prova di acquisto.
- Quando il materiale viene riparato, verrà rispedito all'indirizzo che avrà indicato. Il sistema di invio sarà determinato dalla Recambios Marinos.

È possibile contattare il nostro servizio tecnico della Recambios Marinos attraverso la mail:

[garantias@recambiosmarinos.es](mailto:garantias@recambiosmarinos.es).

9. Tale garanzia comprende solo ed esclusivamente la garanzia relazionata con il prodotto che ha somministrato la Recambios Marinos. Altre garanzie o impegni assunti da qualsiasi altra persona non autorizzata, non sono vincolanti per la Recambios Marinos a meno di previa autorizzazione scritta.



## GARANZIA LIMITATA

	Imbarcazioni da diporto	Navi commerciali o a noleggio
LONG BLOCKS		
SHORT BLOCKS	12 mesi (ricambi e manodopera)	6 mesi (ricambi e manodopera)
PERFORMANCE LONG BLOCKS		NON VI È ALCUNA GARANZIA

Recambios Marinos deciderà se sostituire le parti difettose o tutto il motore. Tutte le riparazioni le effettuerà il venditore/rivenditore a proprie spese, compresa la manodopera, applicabile secondo la politica di manodopera dettagliata più avanti. **È ASSOLUTAMENTE OBBLIGATORIA L'AUTORIZZAZIONE DA PARTE DELLA RECAMBIOS MARINOS PRIMA DI EFFETTUARE** riparazioni in garanzia. Può contattare la Recambios Marinos per avere il numero di autorizzazione. Le riparazioni o le sostituzioni di motore non si estende la validità della presente garanzia limitata.

## TRANSFERIBILE

La presente garanzia è trasferibile e non è limitata all'ultimo acquirente/proprietario al momento della vendita.

## MANODOPERA

Recambios Marinos, s.l. solo paga le spese di manodopera per le riparazioni effettuate in officine autorizzate. First Mate Marine non si fa responsabile di pagare manodopera in riparazioni effettuate da terzi che non sono certificati come meccanici navali (Attestato corrispondente). In nessun caso, il totale che la Recambios Marinos pagherà per la manodopera supererà i 400 € per imbarcazioni fino a 20 piedi, o 470€ per cabinati di 21 piedi o più.

## GLI OBBLIGHI DELL'ACQUIRENTE

Monitorare attentamente i livelli dell'olio durante le prime 100 ore di funzionamento, il consumo di olio potrebbe essere maggiore in questo periodo. Usare un olio di qualità con il giusto grado di viscosità e raccomandato dal costruttore del motore originale. First Mate Marine consiglia di non utilizzare oli o detersivi sintetici l'uso dei quali annullerà totalmente questa garanzia. Un'adeguata pressione dell'olio e la lubrificazione sono obbligatori per il corretto funzionamento del motore. Tutte le imbarcazioni devono essere dotate di orologi o spie che indicano la temperatura motore e pressione dell'olio. **NON FAR GIRARE IL MOTORE IN CASO DI RILEVAMENTO DI UNA INSUFFICIENTE PRESIONE OLIO O DI UNA TEMPERATURA ACQUA INADEGUATA.**

Dopo l'avviamento del motore, evitare accelerare a elevati numeri di giri e lasciare l'imbarcazione planare. Adattare il REGIME durante la 3 a 5 ore di funzionamento. Accelerare a GIRI troppo elevati può causare danni e surriscaldamento al motore e conseguente attrito. Evitare lunghi periodi al minimo. Il surriscaldamento e il guasto del motore a causa della mancanza di lubrificazione può essere evitata se viene monitorato attraverso gli orologi e le spie. La negligenza da parte dell'acquirente per i danni causati al motore annulla automaticamente la garanzia.

## LIMITAZIONI ED ESCLUSIONI

Qualsiasi altra garanzia (comprese quelle che hanno esteso il venditore o che è stato prorogato per un particolare scopo), sono escluse e nessuna di esse variano la validità o i termini di questa garanzia fornita dalla Recambios Marinos. Inoltre, non ci sarà accordo verbale facilitata da terze persone, distributore o venditore che modificare i limiti di garanzia di primo Mate Marine.

FirstMate non è responsabile per:

1. Le riparazioni o danni subiti a causa di un'installazione difettosa, mal uso del motore, inadeguata assistenza tecnica, alterazioni o modifiche non autorizzate, o cattiva gestione.
2. I Componenti non forniti da Recambios Marinos (compresi coperchio distribuzione, i collettori e i gomiti, pompe ad acqua, coppa dell'olio e carburatore o iniezione) o altri.
3. I danni causati dalla detonazione o pre-accensione, compresi i pistoni rotti o fusi, fasce rotte o graffiato, teste o guarnizioni testa cilindro danneggiato o graffiato, graffi sulla camicia o testa dei pistoni.
4. Danni causati da insufficiente lubrificazione del motore prima di metterlo in funzione.

Non possono essere richieste altre spese (dirette o indirette) come la perdita di profitti, le perdite sulle vendite, danni a un'altra persona o proprietà, traino della barca, oli, lubrificanti, filtri, antigelo, guarnizioni, le spese di spedizione, ecc.

[WWW.RECAMBIOSMARINOS.ES](http://WWW.RECAMBIOSMARINOS.ES)

**BARCELONA**

Jocelyn Bell, 26  
Pol. Ca n'Alemany  
08840 Viladecans (Barcelona)  
Tel. 902 10 85 85  
93 633 34 80

International  
phone: (+34) 93 662 66 55

[info@recmar.es](mailto:info@recmar.es)

**GIRONA**

C/ Gironés, 5  
Pol. Ind. El Plà  
17486 Castelló d'Empúries (Girona)  
Tel. 972 158 809

[girona@recmar.es](mailto:girona@recmar.es)

**CANARIAS**

Avda. Los Majuelos, 14  
38108 La Laguna (Tenerife)  
Tel. (+34) 922 621 499  
Móvil 628 592 042

[canarias@recmar.es](mailto:canarias@recmar.es)